



HAL
open science

Non-Singular Assembly-mode Changing Motions for 3-RPR Parallel Manipulators

Mazen Zein, Philippe Wenger, Damien Chablat

► **To cite this version:**

Mazen Zein, Philippe Wenger, Damien Chablat. Non-Singular Assembly-mode Changing Motions for 3-RPR Parallel Manipulators. *Mechanism and Machine Theory*, 2008, 23 (4), pp.480-490. 10.1016/j.mechmachtheory.2007.03.011 . hal-00261669

HAL Id: hal-00261669

<https://hal.science/hal-00261669v1>

Submitted on 7 Mar 2008

HAL is a multi-disciplinary open access archive for the deposit and dissemination of scientific research documents, whether they are published or not. The documents may come from teaching and research institutions in France or abroad, or from public or private research centers.

L'archive ouverte pluridisciplinaire **HAL**, est destinée au dépôt et à la diffusion de documents scientifiques de niveau recherche, publiés ou non, émanant des établissements d'enseignement et de recherche français ou étrangers, des laboratoires publics ou privés.

Non-Singular Assembly-mode Changing Motions for 3-RPR Parallel Manipulators

Mazen ZEIN, Philippe Wenger and Damien Chablat

Institut de Recherche en Communications et Cybernétique de Nantes UMR CNRS 6597

1, rue de la Noë, BP 92101, 44312 Nantes Cedex 03 France

E-mail address: Mazen.Zein@irccyn.ec-nantes.fr

Abstract

When moving from one arbitrary location at another, a parallel manipulator may change its assembly-mode without crossing a singularity. Because the non-singular change of assembly-mode cannot be simply detected, the actual assembly-mode during motion is difficult to track. This paper proposes a global explanatory approach to help better understand non-singular assembly-mode changing motions for 3-RPR planar parallel manipulators. The approach consists in fixing one of the actuated joints and analyzing the configuration-space as a surface in a 3-dimensional space. Such a global description makes it possible to display all possible non-singular assembly-mode changing trajectories.

1. Introduction

Most parallel manipulators have singularities that limit the motion of the moving platform. The most dangerous ones are the singularities associated with the direct kinematics, where two assembly-modes coalesce. Indeed, approaching such a singularity results in large actuator torques or forces, and in a loss of stiffness. Hence, these singularities are undesirable. There exists three main ways of coping with singularities, which have their own merits. A first approach consists in eliminating the singularities at the design stage by properly determining the kinematic architecture, the geometric parameters and the joint limits [1-2]. This approach is safe but difficult to apply in general and restricts the design possibilities. A second approach is the determination of the singularity-free regions in the workspace [3-7]. This solution does not involve a priori design restrictions but, because of the complexity of the singularity surfaces, it may be difficult to determine definitely safe regions. Finally, a third way consists in planning singularity-free trajectories in the manipulator workspace [8-11]. With this solution one is also faced with the complexity of the singularity equations but larger zones of the workspace may be exploited. This paper addresses a feature that has drawn the interest of quite few researchers but yet may concern many parallel manipulators, even planar ones [12, 13]: the fact that the manipulator can change its assembly-mode without passing through a singularity. Planar parallel manipulators with three extensible leg rods, referred to 3-RPR¹, have received a lot of attention because they have interesting potential applications in planar motion systems [12-18]. As shown in [13], moreover, the study of the 3-RPR planar manipulator may help better understand the kinematic behavior of its more complex spatial counterpart, the 6-dof octahedral manipulator. Planar parallel manipulators may have up to six assembly-modes [14]. It was first pointed out that to move from one assembly-mode to another, a 3-RPR planar parallel manipulator should cross a singularity [14]. But [12] showed, using numerical experiments, that this statement is not true in general. In fact, an analogous phenomenon exists in serial manipulators, which can move from one inverse kinematic solution to another without meeting a singularity [12-14]. The non-singular

¹ R and P stand for Revolute and Prismatic, respectively. The underlined letter refers to the actuated joint

change of posture in serial manipulators was shown to be associated with the existence of points in the workspace where three inverse kinematic solutions meet, called cusp points [19]. On the other hand, McAree and Daniel [13] pointed out that a 3-*RPR* planar parallel manipulator can execute a non-singular change of assembly-mode if a point with triple direct kinematic solutions exists in the joint space. The authors established a condition for three direct kinematic solutions to coincide and showed that a non-singular assembly-mode changing trajectory in the joint space should encircle a cusp point. Wenger and Chablat [20] investigated the question of whether a change of assembly-mode must occur or not when moving between two prescribed poses in the workspace. They defined the uniqueness domains in the workspace as the maximal regions associated with a unique assembly-mode and proposed a calculation scheme for 3-*RPR* planar parallel manipulators using octrees. They showed that up to three uniqueness domains exist in each singularity-free region. When the starting and goal poses are in the same singularity-free region but in two distinct uniqueness domains, a non-singular change of assembly-mode is necessary. However they did not investigate the kind of motion that arises when executing a non-singular change of assembly-mode. For the particular case of a planar 3-*RPR* parallel manipulator with similar base and platform, Kong and Gosselin [4] showed that there is no need to investigate non-singular assembly changing motion because each singularity-free region corresponds to one uniqueness domain. But 3-*RPR* manipulators with similar base and platform have a major flaw: the manipulator is singular at all positions when the moving platform assumes a zero orientation. On the other hand, planar 3-*RRR* manipulators and spatial octahedral manipulators with similar base and platform may change their assembly-mode without encountering a singularity [13, 21]. If, when moving from one arbitrary pose to another, the manipulator changes its assembly-mode without crossing a singularity, the actual assembly-mode during motion is difficult to track even if the initial assembly-mode is known, as there is no ways to detect the change of assembly-mode. Therefore, there is a need to understand the non-singular change of assembly-mode. The main goal of this paper is to investigate the non-singular change of assembly-mode in planar 3-*RPR* parallel manipulators, and to propose an explanatory approach to plan non-singular assembly-mode changing trajectories. The approach consists in fixing one of the actuated joints and analyzing the configuration-space as a surface in a 3-dimensional space. Such a global description makes it possible to display all possible non-singular assembly-mode changing trajectories.

2. Preliminaries

2.1 Manipulators Under Study

Figure 1 shows a planar parallel manipulator with three extensible leg rods. The geometric parameters are the three sides of the moving platform d_1, d_2, d_3 and the position of the base revolute joint centers defined by A_1, A_2 and A_3 . The reference frame is centered at A_1 and the x -axis passes through A_2 . Thus, $A_1 = (0, 0)$, $A_2 = (A_{2x}, 0)$ and $A_3 = (A_{3x}, A_{3y})$. The joint space \mathcal{Q} is defined by the joint vectors \mathbf{q} defined by the lengths of the three actuated extensible links: $\mathbf{q} = [\rho_1 \ \rho_2 \ \rho_3]^T$. The task space is usually defined by the set of vectors $\mathbf{x} = [x \ y \ \alpha]^T$ where (x, y) are the Cartesian coordinates of one point of the platform in the plane, chosen as B_1 in this paper, and α is the orientation of the platform in the plane with respect to the x -axis. In this paper, the task space will be more conveniently defined by $\mathbf{x} = [\rho_1 \ \theta_1 \ \alpha]^T$ where (ρ_1, θ_1) are the cylindrical coordinates of B_1 . With these parameters, indeed, it is possible to consider 2-dimensional slices of the joint space and of the workspace by fixing the joint parameter ρ_1 .

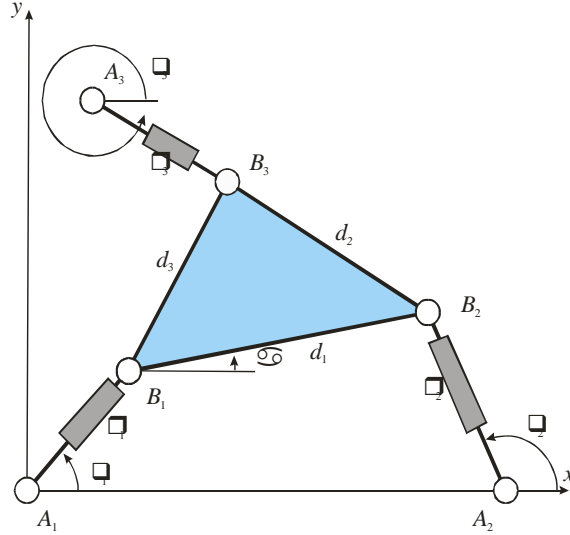

Figure 1: The 3-RPR parallel manipulator under study

To illustrate our work, we refer to the same 3-RPR manipulator as the one used in [12, 13,15], which has the following geometric parameters: $A_1= (0, 0)$, $A_2= (15.91,0)$, $A_3 = (0, 10)$, $d_1= 17.04$, $d_2= 16.54$ and $d_3 = 20.84$ in an arbitrary length unit.

2.2 Kinematic relations

The relation between the joint space \mathbf{Q} and the output space can be expressed as a system of non-linear algebraic equations, which can be written as:

$$F(\mathbf{x}, \mathbf{q}) = 0 \quad (1)$$

Differentiating equation (1) with respect to time leads to the velocity model:

$$\mathbf{A}\mathbf{t} + \mathbf{B}\dot{\mathbf{q}} = \mathbf{0}$$

where $\mathbf{t} = [\omega, \dot{\mathbf{c}}]^T$, ω is the scalar angular velocity and $\dot{\mathbf{c}}$ is the two-dimensional velocity vector of the operational point B_1 of the platform. \mathbf{A} and \mathbf{B} are 3×3 Jacobian matrices which are configuration dependent, and $\dot{\mathbf{q}} = [\dot{\rho}_1 \quad \dot{\rho}_2 \quad \dot{\rho}_3]^T$ is the joint velocity vector.

2.3 Singular configurations

The singularities of the 3-RPR planar parallel manipulators have been extensively studied [13, 16, 22, 24, 25]. On a singular configuration of the manipulator, matrix \mathbf{A} or matrix \mathbf{B} or both of them are singular. In this study, only the singularities of \mathbf{A} are of interest.

To derive the singularity equations, it is usual to expand the determinant of \mathbf{A} . We use rather a geometric approach that does not involve complicated algebraic calculus. The 3-RPR parallel manipulator is on a singular configuration whenever the axes of its three legs are concurrent or parallel [24] (Fig. 2).

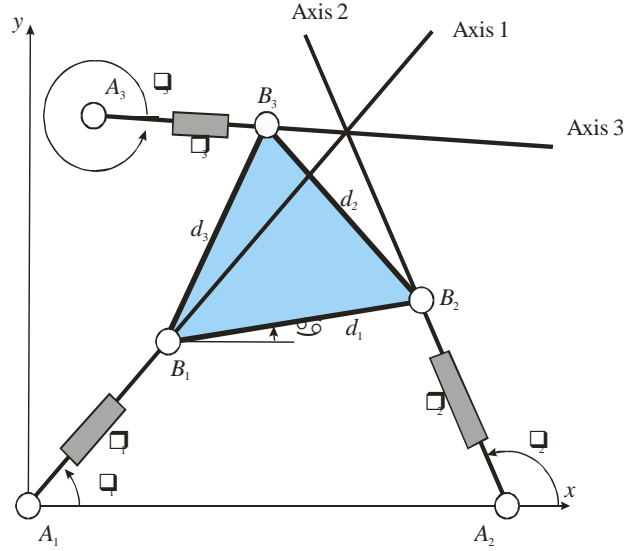

Figure 2: A 3-RPR parallel manipulator in a singular configuration

The equations of the three leg axes can be written as:

$$\begin{cases} (\text{Axis 1}) : y \cos(\theta_1) = x \sin(\theta_1) \\ (\text{Axis 2}) : y \cos(\theta_2) = (x - A_{2,x}) \tan(\theta_2) \\ (\text{Axis 3}) : y \cos(\theta_3) = (x - A_{3,x}) \sin(\theta_3) + A_{3,y} \cos(\theta_3) \end{cases} \quad (2)$$

The condition of these three axes to intersect (possibly at infinity) is:

$$A_{2,x} \sin(\theta_2) \sin(\theta_3 - \theta_1) + (A_{3,x} \sin(\theta_3) - A_{3,y} \cos(\theta_3)) \sin(\theta_1 - \theta_2) = 0 \quad (3)$$

which is the singularity equation of the manipulator. This expression along with the constraint equations of the manipulator (i.e. writing the fixed distances between the three vertices of the mobile platform B_1, B_2, B_3) allow us to plot the singular curves in 2-dimensional slices of the joint space (ρ_2, ρ_3) and of the workspace (α, θ_1) for a fixed value of ρ_1 [13, 26].

2.3.1 Workspace singularities

Figure 3a shows the singular curves in the workspace slice (α, θ_1) defined by $\rho_1=17$ for the manipulator introduced in Section 2.1. Note that because the space (α, θ_1) is a torus (the revolute joints are assumed unlimited) the opposite sides of the square representation in Fig. 3a are actually coincident. Thus, the singularity curves divide the workspace into two connected components called *aspects* [7]. The notion of aspects was first introduced for serial manipulators by [27] to cope with the existence of multiple inverse kinematic solutions. The aspects were defined as the maximal singularity-free domains in the joint space. The aspects were extended in [7] to parallel manipulators with only one inverse kinematic solution such as 3-RPR manipulators. For such manipulators, the aspects are the maximal singularity-free connected regions in the workspace. An equivalent definition was used in [28] for a special case of parallel manipulators.

For the 3-RPR parallel manipulator at hand, the first (resp. second) aspect is defined by $\det(\mathbf{A}) > 0$ (resp. $\det(\mathbf{A}) < 0$), where \mathbf{A} is the Jacobian matrix introduced in Section 2.2.

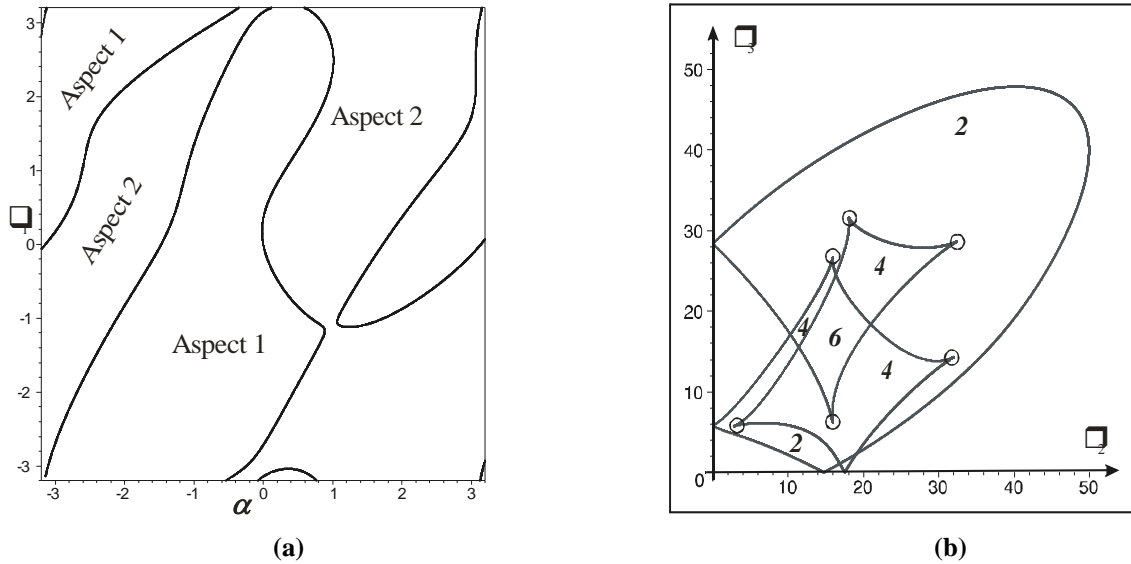

Figure 3: Singular curves in (α, θ) for $\rho_1=17$ (Fig. 3a). Singular curves in (ρ_2, ρ_3) for $\rho_1=17$ (Fig. 3b).

2.3.2 Joint space singularities

Figure 3b shows the singular curves in the joint space slice (ρ_2, ρ_3) defined by $\rho_1=17$. These curves split the joint space slice into several regions with 2, 4 or 6 direct kinematic solutions [26, 29]. The slice of the joint space is the image by the inverse kinematics of each of aspect 1 and also of aspect 2. That is, plotting either aspect 1 or aspect 2 onto (ρ_2, ρ_3) will define the pattern depicted in Fig. 3b. In each region, the number of direct solutions is equally distributed in the two aspects. In the central 6-solution region, for example, there are 3 solutions in aspect 1 and 3 solutions in aspect 2. The six points pinpointed with circles are cusp points, where three direct kinematic solutions coincide. As shown in [26], there may be 0, 2, 4, 6 or 8 cusp points depending on the slice chosen.

3. Examination of a loop trajectory encircling a cusp point in the joint space

We want to understand how a non-singular change of assembly-mode arises. We consider that no external influence enabling the determination of the assembly mode is possible. We only know that to execute a non-singular assembly-mode changing motion, a cusp point must be encircled in the joint space of the manipulator [13]. We show in this section that this information is insufficient to determine the actual motion of the manipulator when a cusp point is encircled in its joint space. Let us define a triangular loop trajectory T in a slice of the joint space for $\rho_1 = 17$, which encircles a cusp point (Fig. 4a). The starting (and final) joint vector $\mathbf{q} = [\rho_1 \ \rho_2 \ \rho_3]^T$ is chosen as $\mathbf{q} = [17 \ 19 \ 17]^T$, where the direct kinematics at \mathbf{q} admits 6 real solutions $P_i, i=1, 2, \dots, 6$. Keeping in mind that the opposite sides of the square representation in Fig. 4b are actually coincident, P_1, P_2 and P_3 are in aspect 1 and the remaining three solutions are in aspect 2. The loop trajectory T crosses the singular curves at four distinct joint configurations, referred to as $\mathbf{q}_a, \mathbf{q}_b, \mathbf{q}_c$ and \mathbf{q}_d . Along T , the direct kinematics is solved and the solutions are plotted in (α, θ) (Fig. 4b). According to whether T is executed clockwise or counter-clockwise and according to the initial assembly-mode, a total of 12 motions will result in the workspace. These 12 motions can be classified into the following three types:

- Motions that make the manipulator stop at one of the singular points S_a, S_b, S_c or S_d , which are associated with $\mathbf{q}_a, \mathbf{q}_b, \mathbf{q}_c$ and \mathbf{q}_d , respectively. There are 8 such motions, 4 for each direction of execution of T . When T is executed clockwise the 4 motions are from P_2 to S_a , from P_1 to S_d , from P_5 to S_a and from P_6 to S_d . When T is

executed counter-clockwise the 4 motions are from P_3 to S_b , from P_1 to S_c , from P_5 to S_b and from P_6 to S_c . In each case, the direct kinematic solution associated with the starting assembly-mode is lost at the singular point and this is the reason why the motion stops and T cannot be fully executed. Thus, no assembly-mode changing is feasible with these motions.

- Two loop motions in the workspace starting and ending at P_4 (Fig. 4b). These two loops differ in their direction of execution (clockwise or counter-clockwise), which depends on the direction of execution of T . These motions do not enable the manipulator to change its assembly-mode because the moving platform goes back to its starting pose in the workspace. Unlike the 8 motions described above, for these two loop motions, T is fully executed. These loop motions feature three segments that are associated with the three linear segments of the triangular trajectory T .
- Two non-singular motions that differ only in their direction of motion (from P_2 to P_3 or from P_3 to P_2 , depending on the starting assembly-mode). The path associated with these motions is drawn in dark grey in Fig. 4b. Again, the path is composed of three segments, each associated with a segment of the triangular trajectory T . But in this case, the arrival assembly-mode is different from the starting one. Thus, these two motions are non-singular assembly-mode changing motions.

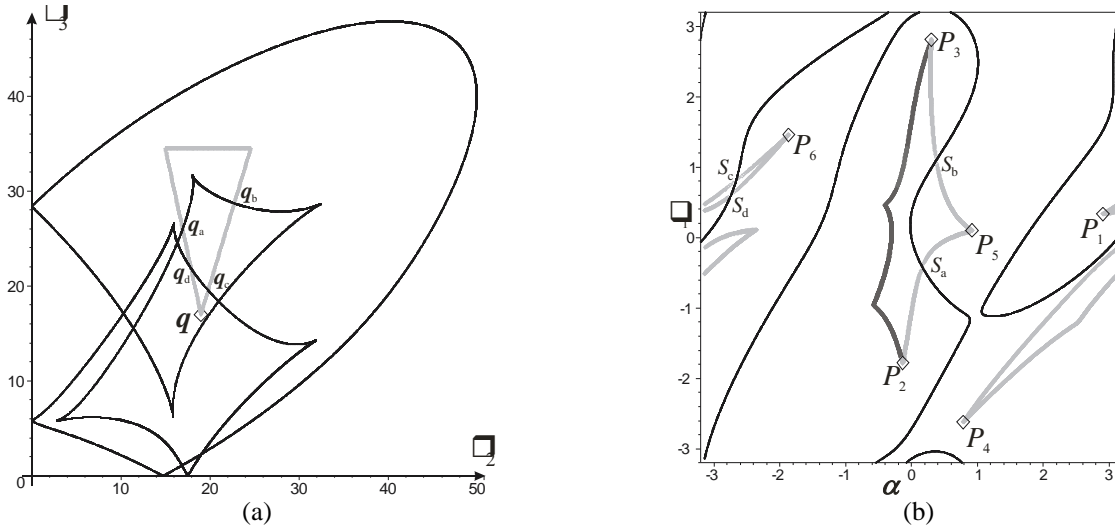

Figure 4: A loop trajectory encircling a cusp point in the joint space section $\rho_1=17$ (Fig. 4a) and the associated motions in the workspace (Fig. 4b).

Finally, this analysis raises the following questions or comments:

- Only two assembly-modes, namely P_2 and P_3 , were found to be linkable by a non-singular assembly-mode changing motion. Yet, other non-singular motions should be found in aspect 1 (e.g. between P_2 and P_1 or between P_3 and P_1) and even in aspect 2.
- What would have been the resulting motions in the workspace if T had encircled another cusp point?
- If one wants to connect two assembly-modes in the workspace associated with the same joint vector \mathbf{q} , without crossing a singularity, which cusp point should be encircled?

Clearly, these questions cannot be answered with the sole information provided by the singularity locus in the joint space and in the workspace.

4. A model for the configuration-space structure

4.1 The configuration-space as a surface in a 3-dimensional space

In the singularity loci shown in Fig. 4, we lose information as these loci result, in fact, from the projection into either (ρ_1, ρ_2, ρ_3) or $(\rho_1, \alpha, \theta_1)$ of the configuration-space CS of the manipulator, which is a 3-dimensional space embedded in the product space of (ρ_1, ρ_2, ρ_3) and $(\rho_1, \alpha, \theta_1)$. When the first leg rod length is fixed, we consider a 2-dimensional slice of the configuration-space, which is thus a surface in a 4-dimensional space (the product space of (ρ_2, ρ_3) and (α, θ_1)). Figure 4 represents its projection onto the planes (ρ_2, ρ_3) and (α, θ_1) . But we cannot depict a surface in a 4-dimensional space.

Because non-singular assembly-mode motions occur only inside an aspect, a configuration-space should be built for each aspect: it is necessary to build CS_1 and CS_2 , the configuration-space in aspects 1 and 2, respectively. In order to show CS_1 and CS_2 , they should be displayed in (ρ_2, ρ_3, α) or in $(\rho_2, \rho_3, \theta_1)$ rather than in the product space of (ρ_2, ρ_3) and (α, θ_1) . But by doing so one should verify that the third parameter is sufficient to describe fully the configuration of the manipulator in an aspect when arbitrary values of the three actuated joints are given. It has been shown recently that for some 3-*RPR* manipulators, called degenerate manipulators, two distinct assembly-modes are always associated with the same α and these two assembly-modes may lie in the same aspect [31]. On the other hand, no manipulators exist that have always two distinct assembly-modes per aspect for the same value of θ_1 [32-32]. Thus, it is possible to build CS_1 and CS_2 in $(\rho_2, \rho_3, \theta_1)$ but not in (ρ_2, ρ_3, α) .

4.2 Construction of the configuration-space in each aspect

Let us fix ρ_1 to the value corresponding to the current configuration of the manipulator. To build CS_1 and CS_2 , the slice (ρ_2, ρ_3) of the joint space is scanned and the parameter θ_1 is determined by solving the characteristic polynomial in θ_1 [31]. The sign of the determinant of the Jacobian matrix is determined. If this sign is positive, the resulting point $(\rho_2, \rho_3, \theta_1)$ is plotted in CS_1 otherwise it is plotted in CS_2 . Figure 5 shows CS_1 and CS_2 when $\rho_1=17$. We have used a CAD interface to build a 3D mesh surface-plot and to enable rotating the viewing perspective. The singular curves, which define the boundaries of CS_1 and CS_2 , have been displayed in bold lines. Their projections onto (ρ_2, ρ_3) are shown in the figure. Assume the manipulator is in the configuration \mathbf{q} shown in Fig. 4. The points associated with the six assembly-modes P_1, P_2, \dots, P_6 are shown (these points have been labeled as P_1, P_2, \dots, P_6 in Fig. 5 like in Fig. 4b for more simplicity). The first three are in aspect 1 while the last three are in aspect 2. This representation shows all feasible singularity-free motions between P_1, P_2 and P_3 as well as those between P_4, P_5 and P_6 .

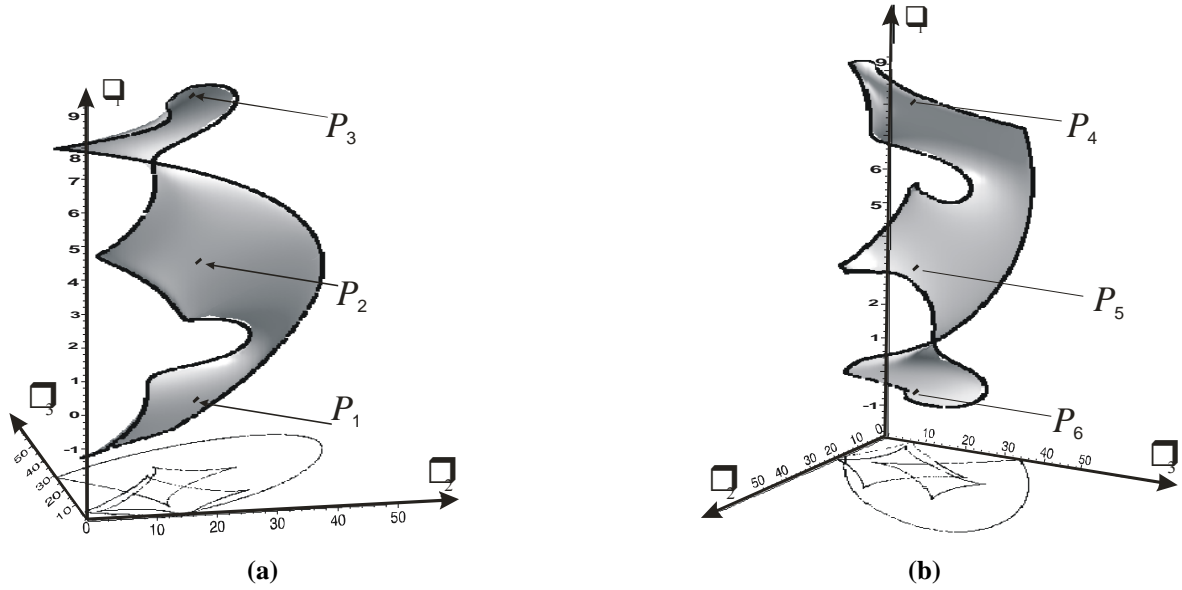

Figure 5: The configuration-space CS_1 (Fig. 5a) and CS_2 (Fig. 5b) associated with aspects 1 and 2, respectively, along with the six assembly-modes calculated at $\mathbf{q} = [17 \ 19 \ 17]^T$ (P_1, P_2 and P_3 in aspect 1 and P_4, P_5 and P_6 in aspect 2). The singularities (shown in bold lines) define the boundaries of CS_1 and CS_2 .

4.3 Examples of non-singular assembly-mode changing trajectories

The following three figures display non-singular assembly-mode changing trajectories in aspect 1. The paths are constructed in $(\rho_2, \rho_3, \theta_1)$. We have used a CAD-interface to define the paths from a set of intermediate points and linear segments. In the three examples shown in Figs 6, 7 and 8, we have defined the path with three intermediate points. The projection of the paths onto (ρ_2, ρ_3) are displayed in each figure to show which cusp is encircled in the joint space. The viewpoints have been chosen to show as clearly as possible the paths in CS_1 .

Figure 6 shows a non singular assembly-mode changing trajectory connecting the two assembly-modes P_1 and P_2 . We notice that the encircled cusp point is different from the one encircled by the trajectory T shown in Fig. 4a.

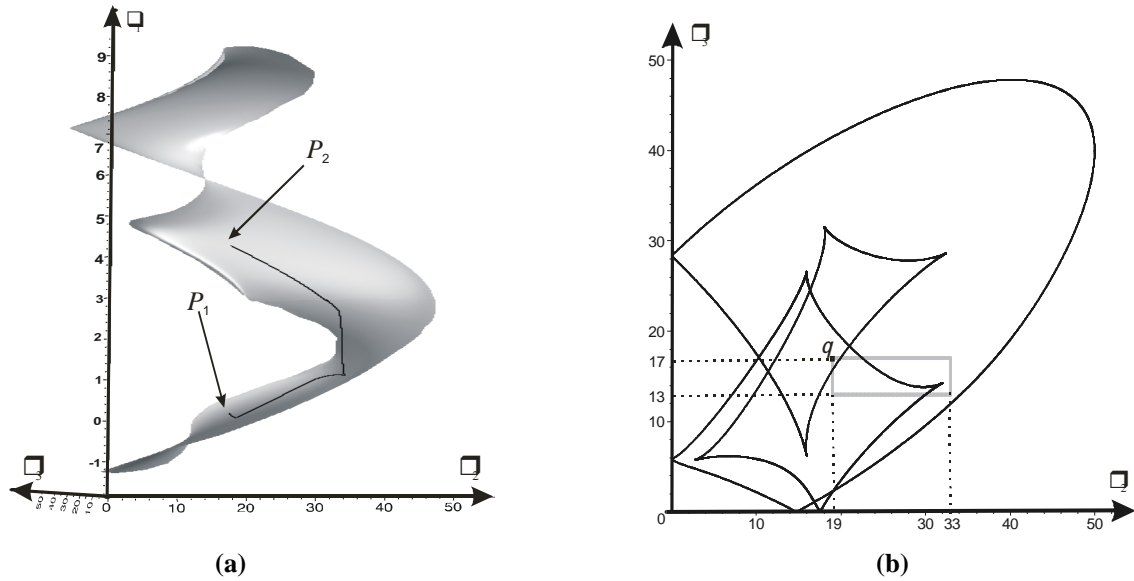

Figure 6: Non-singular assembly-mode changing trajectory connecting the two assembly-modes P_1 and P_2 in the first aspect in $(\rho_2, \rho_3, \theta_1)$ (Fig. 6a), in (ρ_2, ρ_3) (Fig. 6b).

Figure 7 shows a non-singular assembly-mode changing trajectory connecting the two assembly-modes P_2 and P_3 . The

trajectory encircles two cusp points but, in fact, only one needs to be encircled (namely, the one encircled by the trajectory T shown in Fig. 4, left).

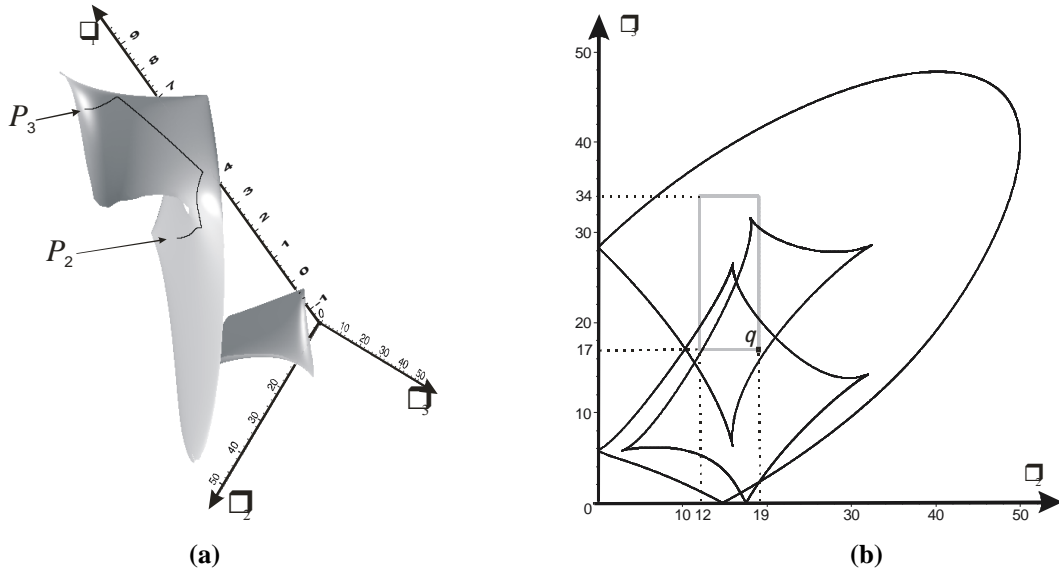

Figure 7: Non-singular trajectory connecting the two assembly-modes P_2 and P_3 in the first aspect in $(\rho_2, \rho_3, \theta_1)$ (Fig. 6a), in (ρ_2, ρ_3) (Fig. 7b).

Finally, Fig. 8 shows a non-singular assembly-mode changing trajectory connecting the two assembly-modes P_1 and P_3 .

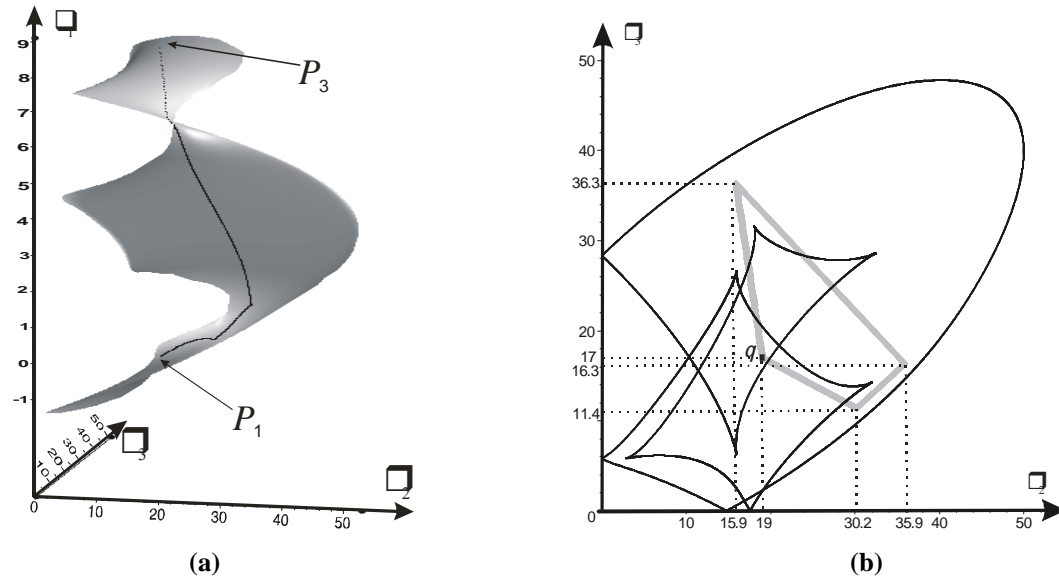

Figure 8: Non-singular trajectory connecting the two assembly-modes P_1 and P_3 in the first aspect in $(\rho_2, \rho_3, \theta_1)$ (Fig. 8a), in (ρ_2, ρ_3) (Fig. 8b).

We notice that to connect the assembly-modes P_1 and P_3 , the trajectory in the joint space encircles two cusp points as shown in Fig. 8b. In fact, we have verified that any path from P_1 and P_3 must encircle these two cusp points. This fact can be explained by the “layered” structure of the configuration-space surfaces (see comments below). This is a new result, since it was thought that only one cusp point should be encircled when executing a non-singular assembly-mode changing maneuver [13]. Clearly, this result could not have been discovered with the sole joint space and workspace representations shown in Fig. 4.

4.4 Comments

Using the configuration-space surface model, the problem of which cusp point should be encircled to plan a non-singular assembly-mode changing motion needs not be solved. However, it is possible to know the response to this question by projecting onto (ρ_2, ρ_3) the path built on CS_1 or CS_2 .

The two configuration-space surfaces CS_1 and CS_2 may be regarded as being composed of three adjacent “layers” L_1, L_2 and L_3 with respect to the θ_1 -coordinate. These three layers are associated with the three assembly-modes P_1, P_2 and P_3 . The first two layers and the last two layers are adjacent and it is possible to move between them with a smooth path. The presence of a cusp point in (ρ_2, ρ_3) accounts for the existence of a continuous link between two layers of CS_1 or of CS_2 . This is why moving from one layer to another (that is, moving from one assembly-mode to another without meeting a singularity) is equivalent to encircling a cusp point. This is because to move from L_1 to L_3 , one has to go on the intermediate layer L_2 that two cusp points must be encircled in (ρ_2, ρ_3) when connecting the two assembly-modes P_1 and P_3 .

5. Conclusions

A global explanatory approach was proposed in this paper to help better understand non-singular assembly-mode changing motions for 3-RPR planar parallel manipulators. It has been shown that the joint space and the workspace are not sufficient to describe the non-singular motions between assembly-modes. The proposed approach consists in fixing one of the actuated joint. Then the configuration-space is reduced to two surfaces in a 3-dimensional space, one for each aspect. Such a global description provides sufficient information as to the configuration space topology and makes it possible to display all possible non-singular assembly-mode changing trajectories that operate with one locked actuator. This approach will be extended to the analysis of non-singular assembly-mode changing trajectories in 6-DOF octahedral parallel manipulators. These manipulators are particular Gough-Stewart platforms that feature a triangular base and a triangular moving platform, connected by six double-spherical-joint-ended rods. This manipulator has eight triangular faces (the base-triangle, the platform-triangle and 6 leg-triangles). The idea is to fix all but two joint coordinates and to build the configuration-space surfaces in $(\rho_5, \rho_6, \theta_1)$, where ρ_5 and ρ_6 are the two free joint coordinates and θ_1 is the dihedral angle between the base and one of the leg-triangles.

We think that the work provided in this paper constitutes a first step to the difficult problem of how to identify the different assembly-modes of a parallel manipulator and how to track the assembly-mode during motion.

6. References

- [1] D. Chablat and P. Wenger, “Architecture Optimization of a 3-DOF Parallel Mechanism for Machining Applications, the Orthoglide,” *IEEE Transactions on Robotics and Automation*, **19**(3), pp 403-410, 2003.
- [2] M. Arsenault and R. Boudreau, “The synthesis of three-degree-of-freedom planar parallel mechanisms with revolute joints (3-RRR) for an optimal singularity free workspace,” *Journal of Robotic Systems*, **21** (5), pp.259–274, 2004.
- [3] H. Li and C.M. Gosselin, “Determination of maximal singularity-free zones in the workspace of planar three-degree-of-freedom parallel mechanisms,” *Mechanism and Machine Theory*, **41** (10), pp. 1157–1167, 2006.
- [4] X. Kong and C.M. Gosselin, “Determination of the uniqueness domains of 3-RPR planar parallel manipulators with similar platforms,” *Proc. Of the 2000 ASME Design Engineering Technical conferences and Computers and Information in Engineering Conference*, Baltimore, Sept 10-13, 2000.

- [5] J-P. Merlet, "Determination of the presence of singularities in 6D workspace of a Gough parallel manipulator," *Proc. ARK, Strobl*, June 29-July 4, pp.39-48, 1998.
- [6] H. Li and C.M. Gosselin, "Determination of maximal singularity-free zones in the six-dimensional workspace of the general Gough-Stewart platform," *Mechanism and Machine Theory*, in press, **42** (4), pp. 497-511, 2007.
- [7] P. Wenger, and D. Chablat, "Definition sets for the direct kinematics of parallel manipulators," *Int. Conference on Advanced Robotics*, pp. 859-864, 1997.
- [8] J-P. Merlet, "Trajectory verification in the workspace for parallel manipulators," *International Journal of Robotics Research*, **13** (4), pp. 326-333, 1994.
- [9] S. Bhattacharya, H. Hatwal, A. Gosh, "Comparison of an exact and an approximate method of singularity avoidance in platform type parallel manipulators," *Mechanism and Machine Theory*, **33** (7), pp. 965-974, 1998.
- [10] A.K. Dash , I.M. Chen, S.H. Yeo, G. Yang "Singularity-free path planning of parallel manipulators using clustering algorithm and line geometry," *Proc. IEEE International Conference on Robotics & Automation*, Taipei, Taiwan, September 14-19, 2003.
- [11] S. Sen, B. Dasgupta, A.K. Mallik, "Variational approach for singularity-free-path-planning of parallel manipulators," *Mechanism and Machine Theory*, **38** (11), pp. 1165-1183, 2003.
- [12] C. Innocenti, and V. Parenti-Castelli, "Singularity-free evolution from one configuration to another in serial and fully-parallel manipulators," *Journal of Mechanical Design*. **120** (1), pp. 73-79, 1998.
- [13] P.R. Mcaree, and R.W. Daniel, "An explanation of never-special assembly changing motions for 3-3 parallel manipulators," *The International Journal of Robotics Research*, **18** (6), pp. 556-574, 1999.
- [14] K.H. Hunt, and E.J.F. Primrose, "Assembly configurations of some In-parallel-actuated manipulators," *Mechanism and Machine Theory*, **28** (1), pp.31-42, 1993.
- [15] J-P. Merlet, "Parallel Robots", *Kluwer Academics*, 2000.
- [16] C. Gosselin, and J. Angeles, "Singularity analysis of closed loop kinematic chains," *IEEE Transactions on Robotics and Automation*, **6** (3), 1990.
- [17] C. Gosselin, J. Sefrioui, and M.J. Richard, "Solution polynomiale au problème de la cinématique directe des manipulateurs parallèles plans à 3 degrés de liberté," *Mechanism and Machine Theory*, **27** (2), pp. 107-119, 1992.
- [18] J. Sefrioui, and C. Gosselin, "On the quadratic nature of the singularity curves of planar three-degree-of-freedom parallel manipulators," *Mechanism and Machine Theory*, **30** (4), pp. 535-551, 1995.
- [19] J. El Omri and P. Wenger: "How to recognize simply a non-singular posture changing 3-DOF manipulator," *Proc. 7th Int. Conf. on Advanced Robotics*, pp. 215-222, 1995.
- [20] P. Wenger, and D. Chablat, "Workspace and assembly-modes in fully parallel manipulators: A descriptive study," *Advances on Robot Kinematics*, Kluwer Academic Publishers, pp.117-126, 1998.
- [21] P. Wenger, and D. Chablat, "The Kinematic Analysis of a Symmetrical Three-Degree-of-Freedom Planar Parallel Manipulator," CISM-IFTOMM Symposium on Robot Design, Dynamics and Control, Montreal, June 2004.
- [22] I. Bonev, D. Zlatanov, and C. Gosselin, "Singularity Analysis of 3-DOF Planar Parallel Mechanisms via Screw Theory," *ASME Journal of Mechanical Design*, **125** (3), pp. 573-581, 2003.
- [23] C.V. Parenti and C. Innocenti, "Spatial open kinematics Chains: Singularities, regions, subregions," *Proc. 7th CISM-IFTOMM Romansy*, Udine, Italy 1988.
- [24] K. H. Hunt, "Geometry of Mechanisms," *Clarendon Press*, Oxford, 1978.

- [25] H. R. Mohammadi Daniali, P. J. Zsombor-Murray, and J. Angeles, "Singularity Analysis of Planar Parallel Manipulators," *Mechanism and Machine Theory*, **30** (5), pp. 665–678, 1995.
- [26] M. Zein, P. Wenger, and D. Chablat, "Singular Curves and Cusp Points in The Joint Space of 3-RPR Parallel Manipulators," *Proc. IEEE International Conference on Robotics & Automation*, Orlando, May 2006.
- [27] P. Borrel, "A study of manipulator inverse kinematic solutions with application to trajectory planning and workspace determination," *Proc. IEEE International Conference on Robotics & Automation*, pp 1180-1185, 1986.
- [28] W. Khalil, D. Murareci, "Kinematic analysis and singular configurations of a class of parallel robots," *Mathematics and Computer in Simulation*, pp. 377-390, 1996.
- [29] M. Zein, P. Wenger, and D. Chablat, "An Algorithm for Computing Cusp Points in the Joint Space of 3-RPR Parallel Manipulators," *Proc. of EuCoMeS, First European Conference on Mechanism Science*, Obergurgl Austria, February 2006.
- [30] P. Wenger, "Uniqueness domains and regions of feasible paths for cuspidal manipulators," *IEEE Transactions on Robotics*, 2004.
- [31] P. Wenger, M. Zein and D. Chablat, "Degeneracy study of the forward kinematics of planar 3-RPR parallel manipulators," *Journal of Mechanical Design*, in press.
- [32] L. Tancredi, "De la simplification et la résolution du modèle géométrique direct des robots parallèles," PhD thesis, École Nationale Supérieure des Mines de Paris, France, 1995.