



HAL
open science

Magnetic shape memory alloy and actuator design.

Jean-Yves Gauthier, Arnaud Hubert, Joël Abadie, Nicolas Chaillet, C.
L'excellent

► **To cite this version:**

Jean-Yves Gauthier, Arnaud Hubert, Joël Abadie, Nicolas Chaillet, C. L'excellent. Magnetic shape memory alloy and actuator design.. Proceedings of the 5th International Workshop on Microfactories, IWMMF'06., Oct 2006, Besançon, France. sur CD ROM - 4 p. hal-00260670

HAL Id: hal-00260670

<https://hal.science/hal-00260670>

Submitted on 4 Mar 2008

HAL is a multi-disciplinary open access archive for the deposit and dissemination of scientific research documents, whether they are published or not. The documents may come from teaching and research institutions in France or abroad, or from public or private research centers.

L'archive ouverte pluridisciplinaire **HAL**, est destinée au dépôt et à la diffusion de documents scientifiques de niveau recherche, publiés ou non, émanant des établissements d'enseignement et de recherche français ou étrangers, des laboratoires publics ou privés.

Magnetic Shape Memory Alloy and Actuator Design

J. Y. Gauthier, A. Hubert, J. Abadie, N. Chaillet
 Laboratoire d'Automatique de Besançon
 UMR CNRS 6596
 24 rue Alain Savary, 25000 Besançon, France
 Phone: 33(0)381402806, Fax: 33(0)381402809
 jygauthi, ahubert, jabadie, chaillet@ens2m.fr

C. LExcellent
 Département de mécanique appliquée
 Institut FEMTO-ST, UMR CNRS 6174
 24 chemin de l'Épitaphe, 25000 Besançon, France
 Phone: 33(0)381666052, Fax: 33(0)381666700
 christian.lexcellent@univ-fcomte.fr

Abstract—In the field of micromechanics, microrobotics and specially microfactories, active materials are used in most cases. They permit high resolution and distributed actuation. In this area, Magnetic Shape Memory Alloys (MSMA) are possible candidates. If a lot of studies deal with MSMA, only few applications use them until now. MSMA are attractive active materials because they have large strain (about 10%) as the classical shape memory alloys (SMA), but can provide a 100 times shorter time response. The main disadvantages of MSMA based actuators are the brittleness of the single-crystal material, the difficulty to apply the strong magnetic field required to obtain sufficient strain and the nonlinear behaviour.

We propose in this paper a novel MSMA based actuator changing the disadvantage of the hysteretic behaviour into an advantage. This device is a push-pull actuator: two pieces of MSMA material act in an opposite way. The magnetic fields are created by coils and concentrated by ferromagnetic circuits. In order to move the central part of the actuator, a current pulse in the first coil is generated. The hysteretic behaviour of the material permits to keep a stable position when no current is applied. A current pulse in the second coil permits to displace the central part in the opposite direction. The stable position depends on the magnitude and the time duration of the current pulses and an infinity of stable positions can be reached. The use of current pulses permits also a reduction of the coil heating (Joule effect losses) and a reduction of the magnetic circuit size.

The performances and characteristics of MSMA are between these of classical SMA and these of piezo-electric materials. A thermo-magneto-mechanical model of our actuator is currently in development in order to design an efficient control law well-adapted to the specific MSMA properties.

I. INTRODUCTION

In the field of micromechanics, microrobotics and specially microfactories, active materials are used in most cases. They permit high resolution and distributed actuation. Considering this, Magnetic Shape Memory Alloys (MSMA) are possible candidates. If a lot of studies concern MSMA, only few applications use them until now [1], [2], [3]. MSMA are attractive active materials because they have large strain (about 10%) as the classical shape memory alloys (SMA), but can provide a 100 times shorter time response.

The first part of this paper presents the general behaviour of MSMA and the actuation properties. The limits of classical design for MSMA based actuator are moreover developed. A new actuation principle and experimental results are then

introduced. Perspectives about our future works are finally given.

II. MAGNETIC SHAPE MEMORY ALLOYS PROPERTIES

A. Principle

MSMA are shape memory alloys that can be activated by magnetic field. Among the MSMA possible alloys, Ni-Mn-Ga alloys are the most widespread and will be studied on this paper.

Figure 1 summarizes the behaviour of Ni-Mn-Ga under temperature, mechanical and magnetic actions.

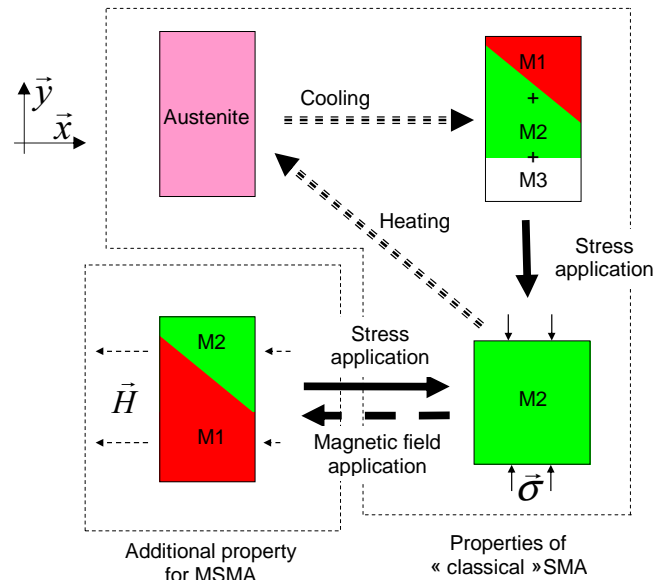

Fig. 1. Behaviour of a MSMA sample.

At high temperature, the MSMA is in austenite crystallographic phase. When the sample is cooled, three martensite variants (M_1 , M_2 and M_3) appear. The M_1 (resp. M_2) variant presents a short axis and an easy magnetization axis in the \vec{y} (resp. \vec{x}) direction. For a xy plane motion, the M_3 phase is not considered. A compressive stress in the \vec{y} direction permits to increase the proportion of the M_2 variant and leads to a displacement into this direction. A magnetic field in the \vec{x}

direction permits to increase the proportion of the M1 variant. Taking into account the hysteretical behaviour of the material, the \vec{y} displacement is therefore controlled by the stress for the reverse direction and by the magnetic field for the forward direction.

Therefore, in addition to "classical" SMA behaviour, this alloy permits a rearrangement of martensite variants by a magnetic field at a constant temperature.

In order to obtain more physical details about the MSMA behaviour, a modelling based on the thermodynamic of irreversible processes can be found in [4]. Crystallographic and energetic considerations are the bases of this magneto-mechanical model. The thermal actuation is not considered in this model.

B. Actuation properties with MSMA

The most interesting property of MSMA concerns the large maximum strain (about the same as the classical SMA). The five-layered modulated (5M) MSMA have about 6% of strain, the seven-layered modulated (7M) 10%, and the maximum strain could be 20% with the non-modulated (NMT). But the last one do not respond currently to a magnetic field.

Moreover, the maximum deformation speed of the material is about a fraction of the speed of sound. So, the speed limitations come from the magnetic field setting time and the dynamical behaviour of the supported charge. For example, a 5.5 % strain was obtained in 0.6 ms and it corresponds to a speed of 1.3 m/s [5].

Because the energy is supplied by a magnetic field, the actuation can be obtained without contact. Electrical wires could be removed in favour of magnetic field.

In micromechatronics, self-sensing properties can be very useful to obtain controlled closed-loop system. In MSMA, the magnetic susceptibility depends on the material sample strain, so the reluctance of the magnetic circuit including ferromagnetic core is a function of the actuator displacement. Therefore displacement estimation can be done through a measurement of the coil inductance.

However, MSMA present restrictions in the following areas:

First, as the energy is not brought by temperature, but by magnetic field, the stress is less than classical SMA (about 2-3 MPa, but could be higher at low temperature [6]).

Secondly, to obtain actuation with the magnetic field, the sample has to be in the martensite phase. So, the operating temperature does not have to exceed the austenite start temperature (at the most 40 °C).

A third limitation concerns the considerable magnetic field necessary to obtain enough strain (on the order of 400 to 800 kA/m).

Moreover, because the single crystal material state, MSMA is very brittle.

Finally, the magneto-mechanical material behaviour is strongly non-linear. A mechanical hysteresis associated to

magnetic nonlinearities need a complex control.

Table I summarizes the previous points. This classification is of course relating to the compared actuator.

Advantages	Drawbacks
Speed	2-3 MPa blocking stress
6 to 10% strain	Hysteresis
Without contact actuation	Strong applied magnetic field
Self-sensing possibilities	Material brittleness
	Temperature sensitivity

TABLE I
MSMA ADVANTAGES AND DRAWBACKS FOR SMART ACTUATOR APPLICATION.

Table II presents a short comparison with others active materials. MSMA have properties between piezoelectric or magnetostrictive material and shape memory alloy. For more details about others active materials, see [7].

	Piezoelect. (PZT)	Magnetostr. (Terf.-D)	SMA (NiTi)	MSMA (Ni-Mn-Ga)
Control mode	electric	magnetic	heat	magnetic
Max. strain (%)	0.1-0.6	0.15-0.2	2-8	6-10
Blocking stress (MPa)	100	70	250	3
Response time	μs	ms	s	ms

TABLE II
COMPARATIVE TABLE OF DIFFERENT ACTIVE MATERIALS.

III. BASIC ACTUATOR AND IMPROVEMENT

A. Basic actuator and limits

In classical MSMA actuator design, the magnetic field is created by a coil and a ferromagnetic core in the \vec{x} direction (see figure 1). An external pre-stress is applied in the \vec{y} direction using a spring to obtain reversible actuation. Figure 2 presents this basic design.

Previous described drawbacks affect this design. Particularly, a high magnetic field and so a high current into the coil have to be maintain to hold a specific strain. The response curve magnetic field versus displacement present very high hysteresis.

Some examples of these actuators are presented in [3].

B. Improvement and new principle

We suggest in this paper a novel MSMA based actuator changing the disadvantage of the hysteretic behaviour into an advantage. This device is a push-pull actuator: two pieces of MSMA material act in an opposite way. The principle of this actuator is summarized on figure 3. The magnetic fields are created by coils and concentrated by ferromagnetic circuits (a). In order to move the central part of the actuator, a current pulse in the first coil is applied (b). The hysteretic behaviour of the material permits to keep a stable position when the current supply is stopped (c). A current pulse in the

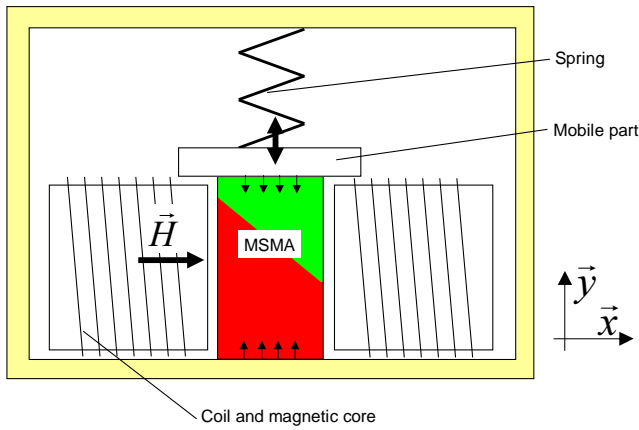

Fig. 2. Basic actuator principle.

second coil permits to move the central part to the opposite direction (d). The stable positions depend on the magnitude and the time duration of the current pulses. Therefore, an infinity of stable positions can be reached. The current pulses approach permits also a reduction of the coil heating (Joule effect losses) and a reduction of the magnetic circuit size.

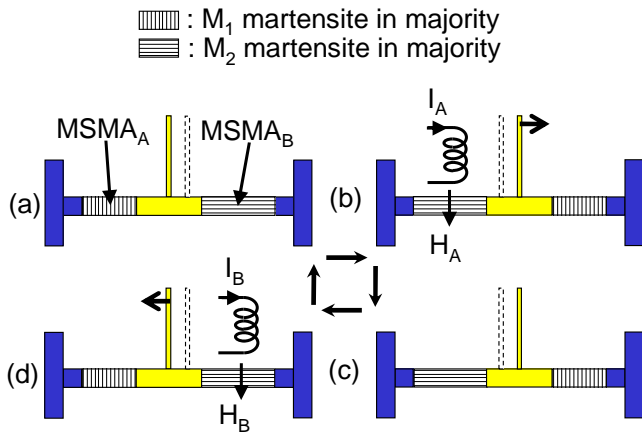

Fig. 3. Push-pull actuator principle.

In [8], a simple model and some numerical simulations of the push-pull actuator working emphasize the previous behaviour.

Some similar actuators using this structure can also be found: an addition of permanent magnets permits to obtain a push pull design with only one coil [9]. This design permits a simpler control but the advantage due to the multistable behaviour of this prototype is not used. The miniaturization of this kind of actuator is possible: an hybrid microactuator that use thin film technologies to create the magnetic field is presented in [10].

C. Experimental test bench

A prototype of push-pull actuator was made in order to test the concept. The figure 4 presents a picture of this

prototype with a schema of the supply and sensing devices. Two independently voltage amplifiers supply the two coils. The measurements of the two currents I_A and I_B are made by resistive shunts. A displacement laser sensor ($10 \mu\text{m}$ of resolution - $100 \mu\text{s}$ of time response) is used in order to obtain the displacement of the actuator mobile part. The system is controlled by a dSpace DSP board and programmed with the help of Matlab[®] and Simulink[®] softwares.

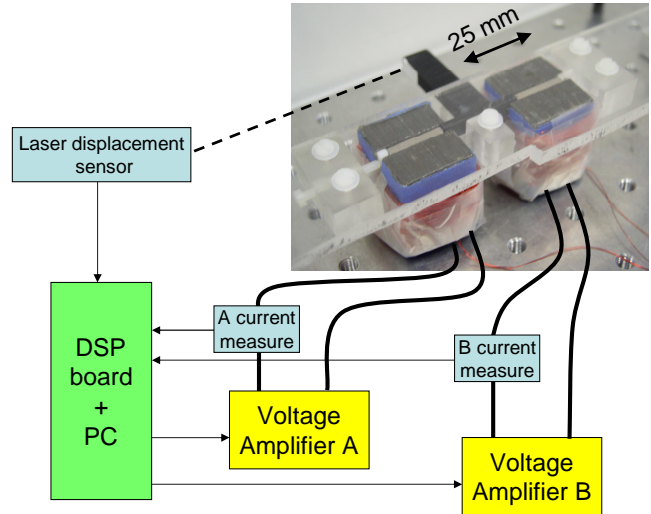

Fig. 4. Picture of the actuator with supply system diagram.

The figure 5 is a typical response curve of the actuator. A current pulse is applied to the A coil, the setting time of the current response is limited by the voltage (100 V in this case). The maximum displacement (about $400 \mu\text{m}$) corresponds to a sample strain of 2%. Finally, a non-reversible motion

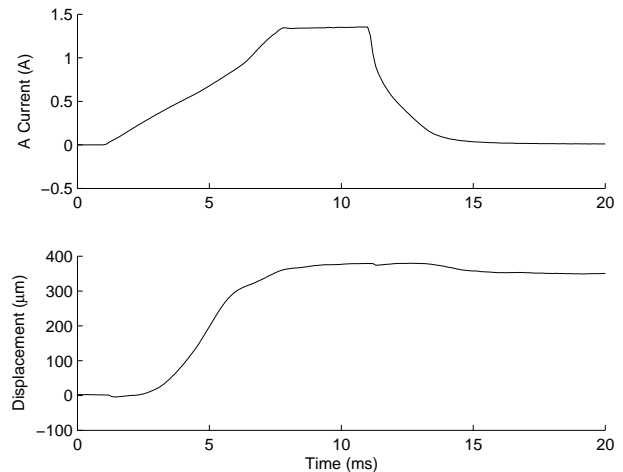

Fig. 5. Current and displacement response of MSMA element A.

is obtained. A small reversible motion also occurs when the current returns to zero.

Figure 6 corresponds to the response of the B element, currents are applied in the B coil and the time duration is

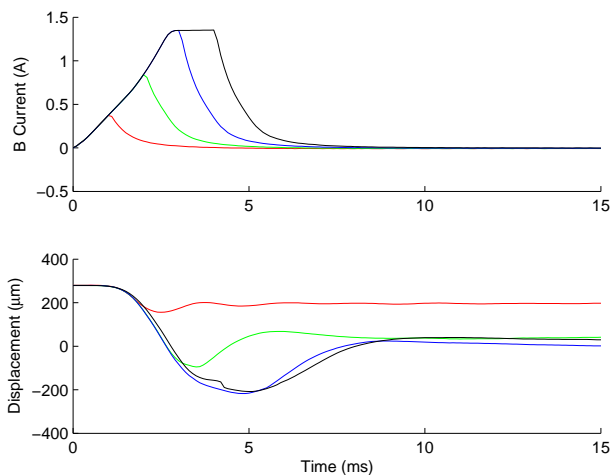

Fig. 6. Current and displacement response of MSMA element B.

included between 1 to 4 ms. The voltage limit is fixed at 200V in this case.

IV. CONCLUSION

The performances and characteristics of MSMA are between these of *classical* SMA and piezo-electric materials. It is then interesting to design actuators using MSMA. Nevertheless, to use them efficiently, it is necessary to take into account their specific properties (hysteresis, magneto-mechanical coupling), that is why, we designed a specific push-pull actuator. A thermo-magneto-mechanical model of this actuator is currently in development and we work on the design of efficient control laws well-adapted to the specific MSMA properties.

REFERENCES

- [1] M. Kohl, D. Brugger, M. Ohtsuka, and T. Takagi, "A novel actuation mechanism on the basis of ferromagnetic sma thin films," *Sensors and Actuators A*, vol. 114, pp. 445–450, 2004.
- [2] I. Suorsa, J. Tellinen, E. Pagounis, I. Aaltio, and K. Ullakko, "Applications of magnetic shape memory actuators," in *8th international conference ACTUATOR 2002*, Bremen (Germany), 2002.
- [3] J. Tellinen, I. Suorsa, A. Jääskeläinen, I. Aaltio, and K. Ullakko, "Basic properties of magnetic shape memory actuators," in *8th international conference ACTUATOR 2002*, Bremen (Germany), 2002.
- [4] J. Y. Gauthier, C. LExcellent, A. Hubert, J. Abadie, and N. Chaillet, "Modeling rearrangement process of martensite platelets in a magnetic shape memory alloy ni2mnga single crystal under magnetic field and (or) stress action," *Journal of intelligent Material Systems and Structures (to be published)*.
- [5] I. Suorsa, E. Pagounis, and K. Ullakko, "Magnetic shape memory actuator performance," *Journal of Magnetism and Magnetic Materials*, vol. 272-276, pp. 2029–2030, 2004.
- [6] H. Karaca, I. Karaman, B. Basaran, Y. Chumlyakov, and H. Maier, "Magnetic field and stress induced martensite reorientation in nimnga ferromagnetic shape memory alloy single crystals," *Acta Materialia*, vol. 54-1, pp. 233–245, 2006.
- [7] J. L. Pons, *Emerging Actuator Technologies: A Micromechatronic Approach*. John Wiley and Sons, inc, 2005.
- [8] J. Y. Gauthier, A. Hubert, J. Abadie, C. LExcellent, and N. Chaillet, "Multistable actuator based on magnetic shape memory alloy," in *ACTUATOR 2006, 10th International Conference on New Actuators, Bremen, Germany*, 2006, pp. 787–790.

- [9] F. Wang, W. Li, Q. Zhang, and X. Wu, "Operation principle and design of a differential magnetic shape memory actuator," in *Fourtieth IAS Annual Meeting*, vol. 3, 2005, pp. 2114–2118.
- [10] H. Gatzen, M. Hahn, and K. Ullakko, "Characterization of magnetic shape memory (msm) material and its application in a hybrid micro actuator," in *ACTUATOR 2006, 10th International Conference on New Actuators, Bremen, Germany*, 2006, pp. 406–409.