



**HAL**  
open science

## Self Organizing Map algorithm and distortion measure

Joseph Rynkiewicz

► **To cite this version:**

Joseph Rynkiewicz. Self Organizing Map algorithm and distortion measure. *Neural Networks*, 2006, 19 (6-7), pp.830-837. 10.1016/j.neunet.2006.05.016 . hal-00257839

**HAL Id: hal-00257839**

**<https://hal.science/hal-00257839v1>**

Submitted on 20 Feb 2008

**HAL** is a multi-disciplinary open access archive for the deposit and dissemination of scientific research documents, whether they are published or not. The documents may come from teaching and research institutions in France or abroad, or from public or private research centers.

L'archive ouverte pluridisciplinaire **HAL**, est destinée au dépôt et à la diffusion de documents scientifiques de niveau recherche, publiés ou non, émanant des établissements d'enseignement et de recherche français ou étrangers, des laboratoires publics ou privés.

# Self Organizing Map algorithm and distortion measure

Joseph Rynkiewicz

SAMOS/MATISSE, Université de Paris-I,

90, rue de Tolbiac 75013 Paris, France,

Tel. and Fax : (+33) 144078705

[joseph.rynkiewicz@univ-paris1.fr](mailto:joseph.rynkiewicz@univ-paris1.fr)

# Self Organizing Map algorithm and distortion measure

---

## Abstract

We study the statistical meaning of the minimization of distortion measure and the relation between the equilibrium points of the SOM algorithm and the minima of distortion measure. If we assume that the observations and the map lie in an compact Euclidean space, we prove the strong consistency of the map which almost minimizes the empirical distortion. Moreover, after calculating the derivatives of the theoretical distortion measure, we show that the points minimizing this measure and the equilibria of the Kohonen map do not match in general. We illustrate, with a simple example, how this occurs.

---

**keywords** Distortion measure, asymptotic convergence, consistency, Self Organizing Map, empirical processes, Glivenko-Cantelli class, uniform law of large numbers, general neighborhood function.

## 1 Introduction

The distortion or distortion measure, is certainly the most popular criterion for assessing the quality of the classification of a Kohonen map (see Kohonen [8]). This measure yields an assessment of model properties with respect to the data and overcomes the absence of cost function in the SOM algorithm. Moreover, the SOM algorithm has been proven to be an approximation for the gradient of distortion measure (see Graepel et al.[6]).

Although the Kohonen map is proven to converge sometimes on equilibria points, when the number of observations tends to infinity, the learning dynamic cannot be described by a gradient descent of distortion measure for an infinite number of observations (see for example Erwin et al. [2]). Moreover, Kohonen [9] has shown in some examples for the one dimensional grid, that the model vector produced by the SOM algorithm does not exactly coincide with the optimum of distortion measure. This property seems to be paradoxical, on one hand SOM seems to minimize the distortion for a finite number of observations, but this behavior is no more true for the limit, i.e. an infinity of observations.

In this paper we will investigate the relationship between the SOM and distortion measure. Firstly we will prove the strong consistency of the estimator minimizing the empirical distortion. More precisely, we will prove that the maps almost minimizing the empirical distortion measure will converge almost surely to the set of maps minimizing the theoretical distortion measure. Secondly, we will calculate the derivatives of the theoretical distortion, and deduce from this calculation that the points minimizing the theoretical distortion differ generally from the equilibrium point of the SOM, whatever the dimension of the grid. Finally we will illustrate, with a simple example, why an apparent contradiction between the discrete and the continuous case occurs.

## 2 Distortion measure

We also assume in the sequel that the observations  $\omega$  are independent and identically distributed (i.i.d.) and are of dimension  $d$ . We assume that the observations lie in an compact space, therefore, without loss of generality, they lie in the compact space  $[0, 1]^d$ . We assume also that these observations follow the probability law  $P$  having a density with respect to the Lebesgue measure of  $\mathbb{R}^d$ , this density is assumed to be bounded by a constant  $B$ . In the sequel we call centroid a vector of  $[0, 1]^d$  representing a class of observations  $\omega$ . We adopt in the sequel the notation of Cottrell et al. [1].

**Definition 2.1** For  $e \in \mathbb{N}^*$ ,  $e \leq d$ , we consider a set of units indexed by  $I \subset \mathbb{Z}^e$  with the neighborhood function  $\Lambda$  from  $I - I := \{i - j, i, j \in I\}$  to  $[0, 1]$  satisfying  $\Lambda(k) = \Lambda(-k)$  and  $\Lambda(0) = 1$ , note that such neighborhood function can be discrete or continuous.

**Definition 2.2** Note  $\|\cdot\|$  the Euclidean norm, let

$$D_I^\delta := \left\{ x := (x_i)_{i \in I} \in \left([0, 1]^d\right)^I, \text{ such that } \|x_i - x_j\| \geq \delta \text{ if } i \neq j \right\}$$

be the set of centroids  $x_i$  separated by, at least,  $\delta$ .

**Definition 2.3** if  $x := (x_i)_{i \in I}$  is the set of units, the Voronoi tessellation  $(C_i(x))_{i \in I}$  is defined by

$$C_i(x) := \left\{ \omega \in [0, 1]^d \mid \|x_i - \omega\| < \|x_k - \omega\| \text{ if } k \neq i \right\}$$

In case of equality we assign  $\omega \in C_i(x)$  thanks to the lexicographical order. Conversely, the index of the Voronoi tessellation for an observation  $\omega$  will be defined by

$$C_x^{-1}(\omega) = i \in I, \text{ if and only if } \omega \in C_i(x)$$

**Definition 2.4** *distortion measures the quality of a quantification with respect to the neighborhood structure. It is defined as follows:*

- *Distortion for the discrete case (empirical distortion): We assume that the observations are in a finite set  $\Omega = \{\omega_1, \dots, \omega_n\}$  and are uniformly distributed on this set. Then, distortion measure is*

$$V_n(x) = \frac{1}{2n} \sum_{i \in I} \sum_{\omega \in C_i(x)} \left( \sum_{j \in I} \Lambda(i-j) \|x_j - \omega\|^2 \right)$$

- *Distortion for the continuous case (theoretical distortion): Let us assume that  $P$  is the distribution function of the observations. The theoretical distortion measure is*

$$V(x) = \frac{1}{2} \sum_{i,j \in I} \Lambda(i-j) \int_{C_i(x)} \|x_j - \omega\|^2 dP$$

*As mentioned before the distribution  $P$  has a density with respect to the Lebesgue measure bounded by a constant  $B > 0$ .*

The distortion measure is well known to be not continuous with respect to the centroids  $(x_i)_{i \in I}$  for the discrete case. Indeed, if an observation is exactly on an hyperplan separating two centroids, shifting one of the centroids will imply a jump for the distortion. So, the distortion is not continuous and, in general, a map which realizes the minimum of the empirical distortion, does not exist. However, if we consider the sequences of maps  $x^n$  such that the distortion  $V_n(x^n)$  will be sufficiently close to its minimum, then we will show that such sequences of maps  $x^n$  will converge almost surely to the set of maps which reaches the minimum of the theoretical distortion measure  $V(x)$ .

### 3 Consistency of the almost minimum of distortion

This demonstration is an extended version of Rynkiewicz [11]. It follows the same line as Pollard [10], so we will first show a uniform law of large numbers and then deduce the strong consistency property.

#### 3.1 Uniform law of large number

Let the family of functions be

$$\mathcal{G} := \left\{ g_x(\omega) := \sum_{j \in I} \Lambda(C_x^{-1}(\omega) - j) \|x_j - \omega\|^2 \text{ for } x \in D_I^\delta \right\} \quad (1)$$

In order to show the uniform law of large numbers, we have to prove that:

$$\sup_{x \in D_I^\delta} \left| \int g_x(\omega) dP_n(\omega) - \int g_x(\omega) dP(\omega) \right| \xrightarrow[n \rightarrow \infty]{a.s.} 0 \quad (2)$$

since, for all probability measure  $Q$  on  $[0, 1]^d$ :

$$\int g_x(\omega) dQ(\omega) = \int \sum_{j \in I} \Lambda(C_x^{-1}(\omega) - j) \|x_j - \omega\|^2 dQ(\omega) = \frac{1}{2} \sum_{i, j \in I} \Lambda(i - j) \int_{C_i(x)} \|x_j - \omega\|^2 dQ(\omega) \quad (3)$$

Now, a sufficient condition to verify the equation (2) is the following (see Gaenssler and Stute [5]):

$\forall \varepsilon > 0, \forall x_0 \in D_I^\delta$  a neighborhood  $S(x_0)$  of  $x_0$  exists such that

$$\int g_{x_0}(\omega) dP(\omega) - \varepsilon < \int \left( \inf_{x \in S(x_0)} g_x(\omega) \right) dP(\omega) \leq \int \left( \sup_{x \in S(x_0)} g_x(\omega) \right) dP(\omega) < \int g_{x_0}(\omega) dP(\omega) + \varepsilon \quad (4)$$

First we prove the following result, using a similar technique as the proof of lemma 11 of Fort and Pagès [3]

**Lemma 3.1** Let  $x \in D_I^\delta$  and  $\lambda$  be the Lebesgue measure on  $[0, 1]^d$ . Note  $E^c$  the complementary set of set  $E$  in  $[0, 1]^d$  and  $|I|$  the cardinal of set  $I$ . For  $0 < \alpha < \frac{\delta}{2}$ , let

$$U_i^\alpha(x) = \{\omega \in [0, 1]^d / \exists y \in D_I^\delta, x_j = y_j \text{ if } j \neq i \text{ and } \|x_i - y_i\| < \alpha \text{ and } \omega \in C_i^c(y) \cap C_i(x)\}$$

be the set of  $\omega$  changing of Voronoi cells when the centroid  $x_i$  are moving a distance of at most  $\alpha$ .

Then

$$\sup_{x \in D_I^\delta} \lambda(U_i^\alpha(x)) < (|I| - 1) \left( \frac{2\alpha}{\delta} + \alpha \right) (\sqrt{2})^{d-1} \quad (5)$$

**proof** Let  $x$  and  $y \in D_I^\delta$  checking the assumption of lemma 3.1 and  $j \neq i \in I$ . In order to prove the inequality, we have to bound the measure of  $\omega$  belonging to the cells  $C_i(x)$  and  $C_j(y)$  simultaneously, since  $(C_i(y))^c = \bigcup_{j \in I, j \neq i} C_j(y)$ .

Note  $(z | t)$ , the inner product between  $z$  and  $t$ , and  $\vec{n}_x^{ij} := \frac{x_j - x_i}{\|x_j - x_i\|}$ . The parameter vector  $x + \gamma_1 \vec{n}_x^{ij}$  will be the vector with all components equal to  $x$  except the component  $i$  equal to  $x_i + \gamma_1 \vec{n}_x^{ij}$ .

Since  $\|y_i - x_i\| < \alpha$ , we have  $(y_i - x_i | \vec{n}_x^{ij}) = \gamma_1$  with  $|\gamma_1| \leq \alpha < \frac{\delta}{2}$ . As the Lebesgue measure (of  $\mathbb{R}^{d-1}$ ) of all plane sections of  $[0, 1]^d$  is bounded by  $(\sqrt{2})^{d-1}$ , when there is a movement of the centroid  $x_i$ , of  $\gamma_1 \vec{n}_x^{ij}$ , the Lebesgue measure of  $\omega$  changing of Voronoi cells is then bounded by  $\frac{|\gamma_1|}{2} (\sqrt{2})^{d-1}$ , so

$$\lambda(C_j(x + \gamma_1 \vec{n}_x^{ij}) \cap C_i(x)) < \alpha (\sqrt{2})^{d-1} \quad (6)$$

Moreover, we note that  $x + \gamma_1 \vec{n}_x^{ij}$  belongs to  $D_I^{\frac{\delta}{2}}$ .

On the other hand, let  $y_i - x_i - \gamma_1 \vec{n}_x^{ij} := \gamma_2 \vec{\tau}_x^{ij}$ , with  $\|\vec{\tau}_x^{ij}\| = 1$ , be the orthogonal component to  $\vec{n}_x^{ij}$  of the movement of  $x_i$  to  $y_i$ , i.e. such that  $(\vec{n}_x^{ij} | \vec{\tau}_x^{ij}) = 0$ .

As it is shown in figure (1), in dimension 2, for all  $x' = x + \gamma_1 \vec{n}_x^{ij} \in D_I^{\frac{\delta}{2}}$ , the Lebesgue measure of  $\omega$  changing of Voronoi cells for a movement of centroid  $x'_i$ , of  $\gamma_2 \vec{\tau}_x^{ij}$  is bounded by  $\frac{2\alpha}{\delta} (\sqrt{2})^{d-1}$ .



Therefore, we have

$$\lambda(C_j(x + \gamma_1 \vec{n}_x^{ij} + \gamma_2 \vec{\tau}_x^{ij}) \cap C_i(x)) < \alpha (\sqrt{2})^{d-1} + \frac{2\alpha}{\delta} (\sqrt{2})^{d-1} \quad (7)$$

Figure 1: hatched area  $< \frac{2\gamma_2}{\delta} < \frac{\sqrt{2} \times 2\alpha}{\delta}$

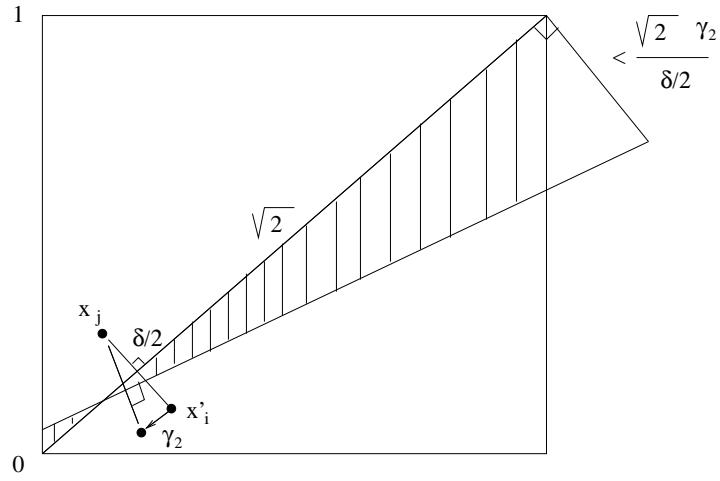

As this inequality is independent of  $x$ , finally we get:

$$\sup_{x \in D_I^\delta} \lambda(C_j(x + \gamma_1 \vec{n}_x^{ij} + \gamma_2 \vec{\tau}_x^{ij}) \cap C_i(x)) < \left( \alpha + \frac{2\alpha}{\delta} \right) (\sqrt{2})^{d-1} \quad (8)$$

then

$$\sup_{x \in D_I^\delta} \lambda(U_i^\alpha(x)) < (|I| - 1) \left( \alpha + \frac{2\alpha}{\delta} \right) (\sqrt{2})^{d-1}$$

■

Now consider  $x^0 \in D_I^\delta$  and  $S(x^0)$  a neighborhood of  $x^0$  included in a sphere of radius  $\alpha$ . Let  $W(x^0)$  be the set of  $\omega$  remaining in their Voronoi cells when  $x^0$  go to any  $x \in S(x_0)$ . For all

$\omega \in W(x^0)$  we have

$$\begin{aligned} \inf_{x \in S(x^0)} g_x(\omega) &\geq g_{x^0}(\omega) - \sum_{j \in I} \Lambda(C_{x^0}^{-1}(\omega) - j) \left( \|x_j^0 - \omega\|^2 - \inf_{x \in S(x^0)} \|x_j^0 - \omega\|^2 \right) \\ &\geq g_{x_j^0}(\omega) - \sum_{j \in I} \left( \|x_j^0 - \omega\|^2 - \inf_{x \in S(x^0)} \|x_j^0 - \omega\|^2 \right) \end{aligned} \quad (9)$$

For all  $\omega \in [0, 1]^d$ , for a small enough  $\alpha$ , we have  $\left( \|x_j^0 - \omega\|^2 - \inf_{x \in S(x^0)} \|x_j - \omega\|^2 \right) < \frac{\varepsilon}{2B|I|}$  so

$$\int_{W(x^0)} \sum_{j \in I} \left( \|x_j^0 - \omega\|^2 - \inf_{x \in S(x^0)} \|x_j - \omega\|^2 \right) dP(\omega) < \frac{\varepsilon}{2} \text{ and } \int_{W(x^0)} \left( g_{x^0}(\omega) - \inf_{x \in S(x^0)} g_x(\omega) \right) < \frac{\varepsilon}{2} \quad (10)$$

Now, let  $W(x^0)^c$  be the set of  $\omega$  changing of Voronoi cells when the centroids go from  $x^0$  to  $x \in S_{x^0}$ . For all  $\omega \in W(x^0)^c$  there exist two different indices  $i$  and  $j$  such that  $\omega \in C_i(x^0)$  and  $\omega \in C_j(x)$ . Let us define a sequence  $x^k$ ,  $k \in \{0, \dots, |I|\}$ , by sequentially changing the components of  $x^0$  into the components of  $x$  such that  $x^{|I|} = x$  ( $x^k$  is the set of intermediate configurations to transform  $x^0$  in  $x$ ), then there exists a moment  $l \in \{0, \dots, |I| - 1\}$ , such that  $\omega \in C_i(x^l)$  and  $\omega \notin C_i(x^{l+1})$ . Indeed, if it were not the case, you could find a sequence  $x^k$ ,  $k \in \{0, \dots, |I|\}$ , with  $x^{|I|} = x$  such that  $\omega \in C_i(x^{|I|}) = C_i(x)$ , which would be a contradiction. So  $W(x^0)^c$  is included in the set of  $\omega$  which change of Voronoi set when we change sequentially the components of  $x^0$  by the components of  $x$ .

If  $\alpha < \frac{\delta}{4}$ , then when the components  $x_i^0$  of  $x^0$  are moving sequentially from  $x^0$  to  $x_i$  of  $x$ , each intermediate configuration stays in  $D_I^{\frac{\delta}{2}}$ . Since, for all  $i \in I$ ,  $\|x_i - \omega\|^2$  is bounded by 1 on  $[0, 1]^d$ , the lemma 3.1, assure that

$$\int_{W(x^0)^c} g_x(\omega) dP(\omega) < B|I|(|I| - 1) \left( \frac{4\alpha}{\delta} + \alpha \right) (\sqrt{2})^{d-1} \quad (11)$$

Finally, if we choose a small enough  $\alpha$  such that  $B|I|(|I| - 1) \left(\frac{4\alpha}{\delta} + \alpha\right) (\sqrt{2})^{d-1} < \frac{\varepsilon}{2}$ , we get

$$\int_{D_I^\delta} g_{x^0}(\omega) dP(\omega) - \varepsilon < \int_{D_I^\delta} \left( \inf_{x \in S(x^0)} g_x(\omega) \right) dP(\omega) \quad (12)$$

Exactly in the same way, for a small enough  $\alpha$ , we get

$$\int_{D_I^\delta} \left( \sup_{x \in S(x^0)} g_x(\omega) \right) dP(\omega) < \int_{D_I^\delta} g_{x^0}(\omega) dP(\omega) + \varepsilon \quad (13)$$

Therefore, the sufficient condition for the uniform law of large numbers is true.

### 3.2 Consistency

We want to show the consistency of the procedure involving choosing maps  $(x^n)_{n \in \mathbb{N}^*}$  which almost minimizes the empirical distortions  $(V_n(x))_{n \in \mathbb{N}^*}$  in  $D_I^\delta$ .

Let

$$\bar{\chi}_n^\beta := \left\{ x \in D_I^\delta \text{ such that } V_n(x) < \inf_{x \in D_I^\delta} V_n(x) + \frac{1}{\beta(n)} \right\} \quad (14)$$

be the set of estimators that almost minimize the empirical distortion, with  $\beta(n)$  being a strictly positive function, such that  $\lim_{n \rightarrow +\infty} \beta(n) = \infty$ . Let  $\bar{\chi} = \arg \min_{x \in D_I^\delta} V(x)$  be the set of maps minimizing the theoretical distortion, eventually reduced to one map. It is easy to verify that the function  $x \mapsto V(x)$  is continuous on  $D_I^\delta$ , so for all neighborhood  $\mathcal{N}$  of  $\bar{\chi}$ ,  $\eta(\mathcal{N}) > 0$  exists such that

$$\forall x \in D_I^\delta \setminus \mathcal{N}, V(x) > \min_{x \in D_I^\delta} V(x) + \eta(\mathcal{N}) \quad (15)$$

to show the strong consistency, it is enough to prove that for all neighborhoods  $\mathcal{N}$  of  $\bar{\chi}$  we have

$$\lim_{n \rightarrow \infty} \bar{\chi}_n^\beta \stackrel{a.s.}{\subset} \mathcal{N} \iff \lim_{n \rightarrow \infty} V(\bar{\chi}_n^\beta) - V(\bar{\chi}) \stackrel{a.s.}{\leq} \eta(\mathcal{N}) \quad (16)$$

with  $V(E) - V(F) := \sup \{V(x) - V(y) \text{ for } x \in E \text{ and } y \in F\}$ . By definition  $V_n(\bar{\chi}_n^\beta) \stackrel{a.s.}{\leq} V_n(\bar{\chi}) + \frac{1}{\beta(n)}$ , and the uniform law of large numbers yields  $\lim_{n \rightarrow \infty} V_n(\bar{\chi}) - V(\bar{\chi}) \stackrel{a.s.}{=} 0$ , we get then  $\lim_{n \rightarrow \infty} V_n(\bar{\chi}_n^\beta) \stackrel{a.s.}{\leq} V(\bar{\chi}) + \frac{\eta(\mathcal{N})}{2}$ . Moreover, we have  $\lim_{n \rightarrow \infty} V(\bar{\chi}_n^\beta) - V_n(\bar{\chi}_n^\beta) \stackrel{a.s.}{=} 0$  and

$$\lim_{n \rightarrow \infty} V(\bar{\chi}_n^\beta) - \frac{\eta(\mathcal{N})}{2} \stackrel{a.s.}{<} \lim_{n \rightarrow \infty} V_n(\bar{\chi}_n^\beta) \stackrel{a.s.}{\leq} V(\bar{\chi}) + \frac{\eta(\mathcal{N})}{2} \quad (17)$$

finally  $\lim_{n \rightarrow \infty} V(\bar{\chi}_n^\beta) - V(\bar{\chi}) \stackrel{a.s.}{\leq} \eta(\mathcal{N})$ , this proves the strong consistency of the maps which almost minimizes the empirical distortion.

## 4 Differences between the SOM algorithm and distortion measure

Using the result of the previous section we can investigate the differences between the minima of the empirical distortion and the equilibria of the SOM algorithm. Namely, if these equilibria were maps almost minimizing the empirical distortion criterion they will converge, as the number of observations increases, to the minimum of the theoretical distortion measure but we will show that it is not generally the case. In the next section we will compute the gradient of the function  $V(x)$ , and show that even in multidimensional cases, the equilibria of the SOM algorithm and the minima of  $V(x)$  do not match. These results generalize the results of Kohonen [9] obtained for unidimensional cases.

### 4.1 Derivability of $V(x)$

Let us now write

$$D_I := \left\{ \left( x_i = \left( x_i^1, \dots, x_i^d \right) \right)_{i \in I} \in \left( [0, 1]^d \right)^I \mid \forall k \in \{1, \dots, d\} \left\| x_i^k - x_j^k \right\| > 0 \text{ if } i \neq j \right\} \quad (18)$$

For  $i$  and  $j \in I$ , notes  $\vec{n}_x^{ij}$  the vector  $\frac{x_j - x_i}{\|x_j - x_i\|}$  and let

$$M_x^{ij} :=: \left\{ u \in \mathbb{R}^d / \left\langle u - \frac{x_i - x_j}{2}, x_i - x_j \right\rangle = 0 \right\} \quad (19)$$

be the mediator hyperplan. Let us note  $\lambda_x^{ij}(\omega)$  the Lebesgue measure on  $M_x^{ij}$ . Fort and Pagès [3], have shown the following lemma:

**Lemma 4.1** *Let  $\phi$  be an  $\mathbb{R}$  valued continuous function on  $[0, 1]^d$ . For  $x \in D_I$ , let be  $\Phi_i(x) := \int_{C_i(x)} \phi(\omega) d\omega$ . We note also  $(e_1, \dots, e_d)$  the canonical base of  $\mathbb{R}^d$ . The function  $\Phi_i$  is continuously derivable on  $D_I$  and  $\forall i \neq j, l \in \{1, \dots, d\}$*

$$\frac{\partial \Phi_i}{\partial x_j^l}(x) = \int_{\bar{C}_i(x) \cap \bar{C}_j(x)} \phi(\omega) \left\{ \frac{1}{2} \langle \vec{n}_x^{ij}, e_l \rangle + \frac{1}{\|x_j - x_i\|} \times \left\langle \left( \frac{x_i + x_j}{2} - \omega \right), e_l \right\rangle \right\} \lambda_x^{ij}(\omega) d\omega \quad (20)$$

Moreover, if we note  $\frac{\partial \Phi_i}{\partial x_i}(x) := \begin{pmatrix} \frac{\partial \Phi_i}{\partial x_i^1}(x) \\ \vdots \\ \frac{\partial \Phi_i}{\partial x_i^d}(x) \end{pmatrix}$

$$\frac{\partial \Phi_i}{\partial x_i}(x) = - \sum_{j \in I, j \neq i} \frac{\partial \Phi_i}{\partial x_j}(x) \quad (21)$$

Then, we deduce the theorem:

**Theorem 4.2** *If  $P(d\omega) = f(\omega) d\omega$ , where  $f$  is continuous on  $[0; 1]^d$ , then  $V$  is continuously*

derivable on  $D_I$  and we have

$$\begin{aligned}
\frac{\partial V}{\partial x_i}(x) &= \sum_{k \in I} \Lambda(i-k) \int_{C_k(x)} (x_i - \omega) P(d\omega) \\
&+ \frac{1}{2} \sum_{j \in I} \sum_{k \in I, k \neq i} (\Lambda(k-j) - \Lambda(i-j)) \\
&\times \int_{\bar{C}_k(x) \cap \bar{C}_i(x)} \|x_j - \omega\|^2 \left( \frac{1}{2} \overrightarrow{n}_x^{ki} + \frac{1}{\|x_k - x_i\|} \times \left( \frac{x_i + x_k}{2} - \omega \right) \right) \\
&f(\omega) \lambda_x^{ki} d\omega
\end{aligned} \tag{22}$$

$$\text{where } \frac{\partial V}{\partial x_i}(x) = \begin{pmatrix} \frac{\partial V}{\partial x_i^1}(x) \\ \vdots \\ \frac{\partial V}{\partial x_i^d}(x) \end{pmatrix}$$

**Proof** As the function  $V(x)$  is continuous on  $D_I$ , we only have to show that the partial derivatives exist and are continuous. We note  $h_i^l \in \mathbb{R}^{|I| \times d}$  the vector with all components null except the component corresponding to  $x_i^l$ , which is  $h > 0$ . Then

$$\begin{aligned}
\frac{V(x+h_i^l) - V(x)}{h} &= \\
&\frac{\frac{1}{2} \sum_{k, j \in I, k, j \neq i} \Lambda(k-j) \int_{C_k(x+h_i^l)} \|x_j - \omega\|^2 P(d\omega) - \frac{1}{2} \sum_{k, j \in I, k, j \neq i} \Lambda(k-j) \int_{C_k(x)} \|x_j - \omega\|^2 P(d\omega)}{h} \\
&+ \frac{\frac{1}{2} \sum_{j \in I, j \neq i} \Lambda(i-j) \int_{C_i(x+h_i^l)} \|x_j - \omega\|^2 P(d\omega) - \frac{1}{2} \sum_{j \in I, j \neq i} \Lambda(i-j) \int_{C_i(x)} \|x_j - \omega\|^2 P(d\omega)}{h} \\
&+ \frac{\frac{1}{2} \sum_{k \in I, k \neq i} \Lambda(k-i) \int_{C_k(x+h_i^l)} \|x_i + h_i^l - \omega\|^2 P(d\omega) - \int_{C_k(x)} \|x_i - \omega\|^2 P(d\omega)}{h} \\
&+ \frac{\frac{1}{2} \left( \int_{C_i(x+h_i^l)} \|x_i + h_i^l - \omega\|^2 P(d\omega) - \int_{C_i(x)} \|x_i - \omega\|^2 P(d\omega) \right)}{h}
\end{aligned} \tag{23}$$

Where the first two lines of the sums concern centroids different from  $x_i$  and the last two lines the variation involving  $x_i$ . Now, by applying the lemma 4.1, to the first two lines of the sum we get:

$$\begin{aligned}
\lim_{h \rightarrow 0} \frac{V(x+h_i^l) - V(x)}{h} &= \frac{1}{2} \sum_{k,j \in I, k,j \neq i} \Lambda(k-j) \\
&\int_{\bar{C}_k(x) \cap \bar{C}_i(x)} \|x_j - \omega\|^2 \left\{ \frac{1}{2} \left\langle \vec{n}_x^{ki}, e_l \right\rangle + \frac{1}{\|x_i - x_k\|} \times \left\langle \left( \frac{x_k + x_i}{2} - \omega \right), e_l \right\rangle \right\} \lambda_x^{ki}(\omega) d\omega \\
&- \frac{1}{2} \sum_{k,j \in I, k,j \neq i} \Lambda(i-j) \\
&\int_{\bar{C}_k(x) \cap \bar{C}_i(x)} \|x_j - \omega\|^2 \left\{ \frac{1}{2} \left\langle \vec{n}_x^{ki}, e_l \right\rangle + \frac{1}{\|x_i - x_k\|} \times \left\langle \left( \frac{x_k + x_i}{2} - \omega \right), e_l \right\rangle \right\} \lambda_x^{ki}(\omega) d\omega \\
&+ \lim_{h \rightarrow 0} \frac{\frac{1}{2} \sum_{k \in I, k \neq i} \Lambda(k-i) \int_{C_k(x+h_i^l)} \|x_i - \omega\|^2 + 2h(x_i^l - w^l) + o(h) P(d\omega) - \int_{C_k(x)} \|x_i - \omega\|^2 P(d\omega)}{h} \\
&+ \lim_{h \rightarrow 0} \frac{\frac{1}{2} \left( \int_{C_i(x+h_i^l)} \|x_i - \omega\|^2 + 2h(x_i^l - w^l) + o(h) P(d\omega) - \int_{C_i(x)} \|x_i - \omega\|^2 P(d\omega) \right)}{h}
\end{aligned} \tag{24}$$

Then, by applying the lemma 4.1 to the last two lines, we get:

$$\begin{aligned}
\lim_{h \rightarrow 0} \frac{V(x+h_i^l) - V(x)}{h} &= \frac{1}{2} \sum_{k,j \in I, k,j \neq i} (\Lambda(k-j) - \Lambda(i-j)) \\
&\int_{\bar{C}_k(x) \cap \bar{C}_i(x)} \|x_j - \omega\|^2 \left\{ \frac{1}{2} \left\langle \vec{n}_x^{ki}, e_l \right\rangle + \frac{1}{\|x_i - x_k\|} \times \left\langle \left( \frac{x_k + x_i}{2} - \omega \right), e_l \right\rangle \right\} \lambda_x^{ki}(\omega) d\omega \\
&+ \frac{1}{2} \sum_{k \in I, k \neq i} \Lambda(k-i) \\
&\int_{\bar{C}_k(x) \cap \bar{C}_i(x)} \|x_i - \omega\|^2 \left\{ \frac{1}{2} \left\langle \vec{n}_x^{ki}, e_l \right\rangle + \frac{1}{\|x_i - x_k\|} \times \left\langle \left( \frac{x_k + x_i}{2} - \omega \right), e_l \right\rangle \right\} \lambda_x^{ki}(\omega) d\omega \\
&- \frac{1}{2} \sum_{k \in I, k \neq i} \int_{\bar{C}_k(x) \cap \bar{C}_i(x)} \|x_i - \omega\|^2 \left\{ \frac{1}{2} \left\langle \vec{n}_x^{ki}, e_l \right\rangle + \frac{1}{\|x_i - x_k\|} \times \left\langle \left( \frac{x_k + x_i}{2} - \omega \right), e_l \right\rangle \right\} \lambda_x^{ki}(\omega) d\omega \\
&+ \sum_{k \in I} \Lambda(k-i) \int_{C_k(x)} (x_i^l - w^l) P(d\omega)
\end{aligned} \tag{25}$$

finally

$$\begin{aligned}
\lim_{h \rightarrow 0} \frac{V(x+h_i^l) - V(x)}{h} &= \frac{\partial V}{\partial x_i^l}(x) = \frac{1}{2} \sum_{k,j \in I, k \neq i} (\Lambda(k-j) - \Lambda(i-j)) \\
&\int_{\bar{C}_k(x) \cap \bar{C}_i(x)} \|x_j - \omega\|^2 \left\{ \frac{1}{2} \left\langle \vec{n}_x^{ki}, e_l \right\rangle + \frac{1}{\|x_i - x_k\|} \times \left\langle \left( \frac{x_k + x_i}{2} - \omega \right), e_l \right\rangle \right\} \lambda_x^{ki}(\omega) d\omega \\
&+ \sum_{k \in I} \Lambda(k-i) \int_{C_k(x)} (x_i^l - w^l) P(d\omega) \blacksquare
\end{aligned} \tag{26}$$

If we assume that the minimum of distortion measure is reached in the interior of  $D_I$  (i.e. that no centroids collapse), we deduce from the previous results that it does not match the equilibrium of the Kohonen algorithm. Indeed, a point  $x^* := (x_i^*)_{i \in I}$  asymptotically stable for the Kohonen

algorithm will verify for all  $i \in I$ :

$$\sum_{k \in I} \Lambda(i - k) \int_{C_k(x)} (x_i - \omega) P(d\omega) = 0 \quad (27)$$

This equation is valid even for the batch algorithm (see Fort, Cottrell and Letrémy [4]). It can match with a minimum of the limit distortion only if

$$\begin{aligned} & \frac{1}{2} \sum_{j \in I} \sum_{k \in I, k \neq i} (\Lambda(k - j) - \Lambda(i - j)) \\ & \times \int_{\bar{C}_k(x) \cap \bar{C}_i(x)} \|x_j - \omega\|^2 \left( \frac{1}{2} \vec{n}_x^{ki} + \frac{1}{\|x_k - x_i\|} \times \left( \frac{x_i + x_k}{2} - \omega \right) \right) f(\omega) \lambda_x^{ki} d\omega = 0 \end{aligned} \quad (28)$$

but, in general, this term is not null.

## 4.2 Example of a Kohonen string with 3 centroids

The previous section has shown that the minimum of distortion measure does not match the equilibrium of the Kohonen algorithm. We will illustrate this with a simple example. The classical explanation (see Kohonen [7]) of local potential minimization by the Kohonen algorithm is far from being satisfactory. Actually it seems that the minima of the distortion measure always occur on a discontinuity point, where the function is not derivable.

To illustrate this, let a Kohonen string be on segment  $[0, 1]$  (see figure 2), with a discrete neighborhood



Figure 2: Kohonen string

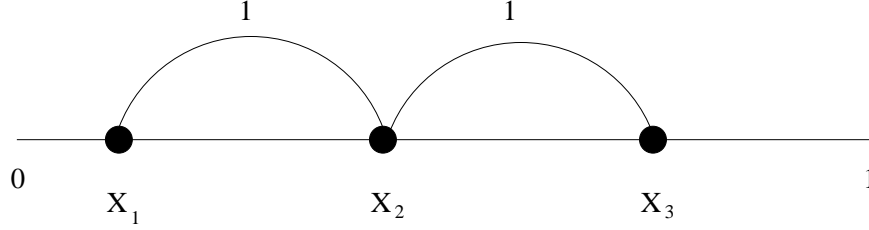

#### 4.2.1 The theoretical difference

The equilibrium of the SOM algorithm is reached on points  $x$  verifying

$$\begin{aligned} \frac{\partial V}{\partial x_1}(x) &= \int_{C_1(x)} (x_1 - \omega) P(d\omega) + \int_{C_2(x)} (x_1 - \omega) P(d\omega) = 0 \\ \frac{\partial V}{\partial x_2}(x) &= \int_{C_1(x)} (x_2 - \omega) P(d\omega) + \int_{C_2(x)} (x_2 - \omega) P(d\omega) + \int_{C_3(x)} (x_2 - \omega) P(d\omega) = 0 \\ \frac{\partial V}{\partial x_3}(x) &= \int_{C_2(x)} (x_3 - \omega) P(d\omega) + \int_{C_3(x)} (x_3 - \omega) P(d\omega) = 0 \end{aligned} \quad (29)$$

but the minima of the distortion are reached on points  $x$  verifying

$$\begin{aligned} \frac{\partial V}{\partial x_1}(x) &= \int_{C_1(x)} (x_1 - \omega) P(d\omega) + \int_{C_2(x)} (x_1 - \omega) P(d\omega) - \frac{1}{4} \left\| x_3 - \frac{x_1+x_2}{2} \right\|^2 f\left(\frac{x_1+x_2}{2}\right) = 0 \\ \frac{\partial V}{\partial x_2}(x) &= \int_{C_1(x)} (x_2 - \omega) P(d\omega) + \int_{C_2(x)} (x_2 - \omega) P(d\omega) + \int_{C_3(x)} (x_2 - \omega) P(d\omega) \\ &\quad - \frac{1}{4} \left\| x_3 - \frac{x_1+x_2}{2} \right\|^2 f\left(\frac{x_1+x_2}{2}\right) + \frac{1}{4} \left\| x_1 - \frac{x_3+x_2}{2} \right\|^2 f\left(\frac{x_3+x_2}{2}\right) = 0 \\ \frac{\partial V}{\partial x_3}(x) &= \int_{C_2(x)} (x_3 - \omega) P(d\omega) + \int_{C_3(x)} (x_3 - \omega) P(d\omega) + \frac{1}{4} \left\| x_1 - \frac{x_2+x_3}{2} \right\|^2 f\left(\frac{x_2+x_3}{2}\right) = 0 \end{aligned} \quad (30)$$

If we assume, for example, that the density of observations is uniform  $\mathcal{U}_{[0;1]}$ , i.e.  $f(x) = 1$  if  $x \in [0; 1]$ , then these two sets of points have no point in common. Indeed, if the two sets are equal then

$$\begin{cases} x_3 - \frac{x_1+x_2}{2} = 0 \\ x_1 - \frac{x_2+x_3}{2} = 0 \end{cases} \quad (31)$$

Therefore,  $x_1 = x_2 = x_3$ , but this point is clearly not an equilibrium of the Kohonen map.

#### 4.2.2 Illustration of the behavior of distortion measure

We will see that if one draws data with a uniform distribution on the segment  $[0, 1]$  and then one computes the minimum of the distortion, then this minimum is always on a discontinuity point. The more observations one has, the more discontinuities there are, but the global function looks more and more regular. This is not surprising, since we know that the limit is derivable.

**The method of simulation** Since we have no numerical algorithm to compute the exact minimum of variance, we proceed by exhaustive research based on a discretization of the space of the centroids. To avoid too much computation, 0.001 is chosen as the discretization step. The following figures are obtained in the following way:

1. Simulate  $n$  “data”  $(\omega_1, \dots, \omega_n)$ , chosen with a uniform law on  $[0, 1]$ .
2. Search exhaustively, on the discretization of  $D_I$ , the string which minimizes the distortion.
3. For the best string  $(x_1^*, x_2^*, x_3^*)$ , the graphical representations are obtained in the following way:
  - 3D Representation: we keep one centroid in the triplet  $(x_1^*, x_2^*, x_3^*)$ , then we move the other around a small neighborhood of its optimal position. The level  $z$  is the extended variance multiplied by the number of observations  $n$ .
  - 2D Representation: we keep two centroids in the triplet  $(x_1^*, x_2^*, x_3^*)$ , then we move the last one around a small neighborhood of its optimal position. The level  $z$  is the extended variance multiplied by the number of observations  $n$ .

The following figures show the results obtained for a number of observations  $n$  varying from 10, 100 and 1000. We notice that, even for a small number of observations, the minima are always on discontinuity points.

Figure 3: Distortion measure for 10 observations

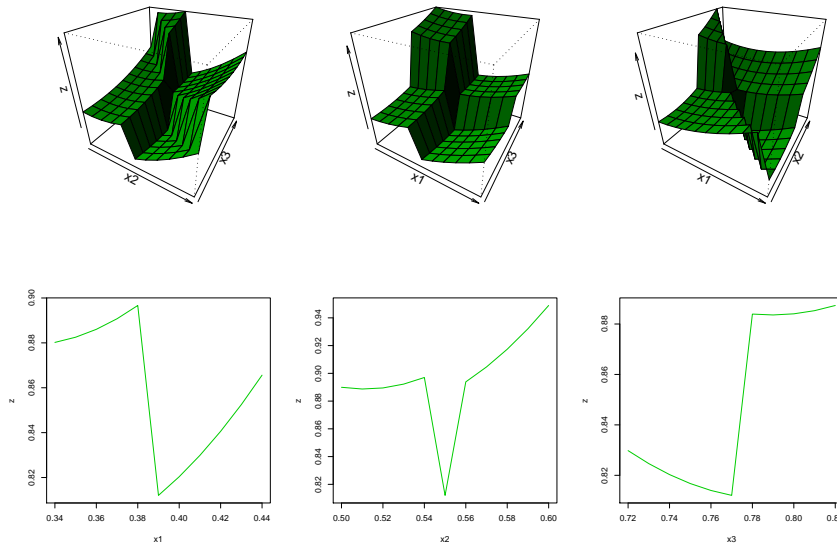

Figure 4: Distortion measure for 100 observations

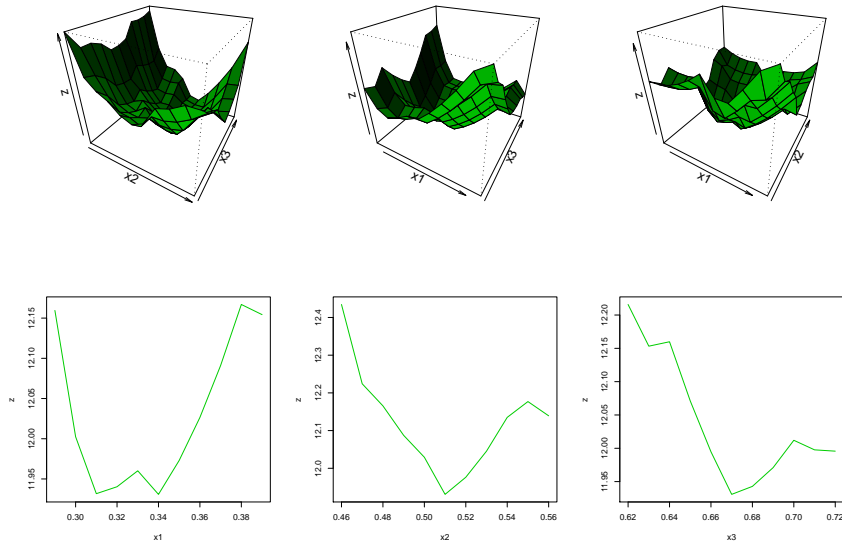
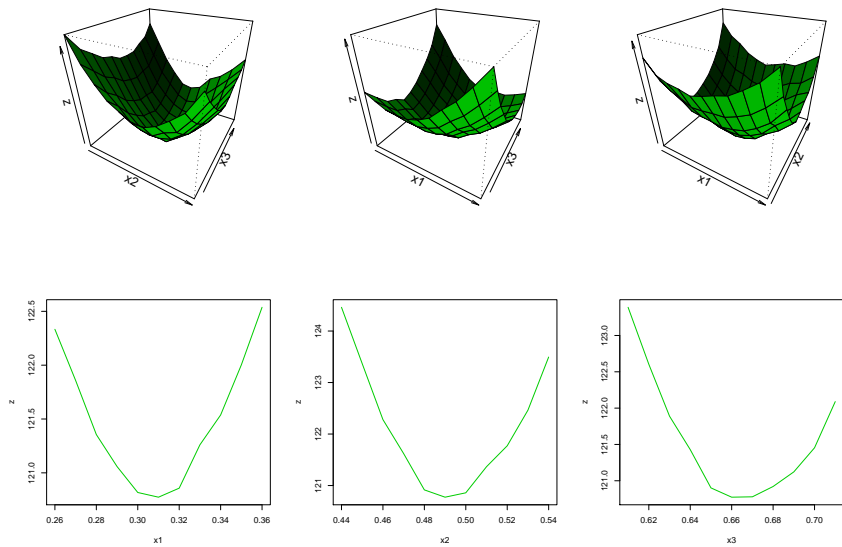

Figure 5: Distortion measure for 1000 observations



## 5 Conclusion

For a finite number of observations, the Kohonen algorithm was supposed to give an approximation of the minimum of distortion measure, but if it were the case, then why can the points of equilibrium of the algorithm be different from the theoretical minimum of distortion? Moreover, we have shown that if we choose maps that almost minimize the empirical distortion, then these maps have to converge to the set of maps which minimize the theoretical distortion. But, by calculating the derivative of the theoretical distortion, we have shown that the equilibria of the Kohonen map can not minimize this distortion in general. We illustrate this fact with an example where the minimum is always reached on discontinuity points. This fact proves that the local derivability of distortion measure is not an important property and is not a satisfactory explanation for the behavior of the Kohonen algorithm when the number of observations is finite.

## References

- [1] Cottrell M., Fort, J.C. and Pagès G. (1998). Theoretical aspects of the SOM algorithm. *Neurocomputing*, **21**. 119-138.
- [2] Erwin, E., Obermayer, K. and Schulten, K. (1992). Self-Organizing Maps: Ordering, Convergence properties and Energy Functions. *Biological Cybernetics*, **67**. 47-55.
- [3] Fort, J.C. and Pagès G. (1995). On the a.s. convergence of the Kohonen algorithm with a general neighborhood function. *The Annals of Applied Probability*, **5(4)**. 1177-1216.
- [4] Fort, J.C., Letrémy, P. and Cottrell M. (2002). Advantages and drawbacks of the batch Kohonen algorithm. In M. Verleysen (ed.), *Proceedings of ESANN 2002* (pp. 223-230). Brussels: Di Facto.

- [5] Gaenssler, P., Stute, W. (1979). Empirical processes: A survey of results for independent and identically distributed random variables. *The Annals of Probability*, **7:2** 193-243
- [6] Graepel, T., Burger M. and Obermayer, K. (1997). Phase transition in stochastic self organizing maps. *Physical review*, **E(56)**. 3876-3890.
- [7] Kohonen, T. (1995). Self-Organizing Maps. *Springer Series in Information sciences*, **30**. New York: Springer-Verlag.
- [8] Kohonen, T. (1991). Artificial neural networks, **2**. Amsterdam: North Holland.
- [9] Kohonen, T. (1999). Comparison of SOM points densities based on different criteria. *Neural Computation*, **11**. 2081-2095.
- [10] Pollard, D. (1981). Strong consistency of k-mean clustering. *the Annals of statistics*, **9(1)**. 135-140.
- [11] Rynkiewicz, J. (2005). Consistency of a least extended variance estimator (in French). *Comptes rendus de l'Académie des Sciences*, **I(345)**. 133-136.