



HAL
open science

Estimation of the Region of Attraction for a Boost DC-AC Converter Control Law

Carolina Albea-Sanchez, Francisco Gordillo

► **To cite this version:**

Carolina Albea-Sanchez, Francisco Gordillo. Estimation of the Region of Attraction for a Boost DC-AC Converter Control Law. The 7th IFAC Symposium on Nonlinear Control Systems, Nolcos 2007, Aug 2007, Pretoria, South Africa. pp.874-879. hal-00256634

HAL Id: hal-00256634

<https://hal.science/hal-00256634>

Submitted on 15 Feb 2008

HAL is a multi-disciplinary open access archive for the deposit and dissemination of scientific research documents, whether they are published or not. The documents may come from teaching and research institutions in France or abroad, or from public or private research centers.

L'archive ouverte pluridisciplinaire **HAL**, est destinée au dépôt et à la diffusion de documents scientifiques de niveau recherche, publiés ou non, émanant des établissements d'enseignement et de recherche français ou étrangers, des laboratoires publics ou privés.

ESTIMATION OF THE REGION OF ATTRACTION FOR A BOOST DC-AC CONVERTER CONTROL LAW^{*}

Carolina Albea^{*} Francisco Gordillo^{*}

^{} Escuela Superior de Ingenieros, Universidad de Sevilla.
Camino de los Descubrimientos s/n. Sevilla-41092. Spain
E-mail: calbea@cartuja.us.es, gordillo@esi.us.es*

Abstract: In this paper is estimated the region of attraction of the nonlinear boost DC-AC converter by Sum of Squares. This is an optimization problem of maximization of the Lyapunov surface subjects to certain strict constraints due to saturation of the control variables of the system and to the composition of the inverter, which is formed from two DC-DC converters with positive voltage.

1. INTRODUCTION

The control of boost DC-AC converters is usually accomplished tracking a reference (sinusoidal) signal. The use of this external signal makes the closed-loop control system to be non-autonomous and thus, making its analysis involved. In (Gordillo *et al.*, 2004; Pagano *et al.*, 2005) a different approach was used: a control law was designed for the boost converter in order to stabilize a limit cycle corresponding to the desired behavior. No external signals were needed. Nevertheless, the use of a boost converter prevents the achievement of zero-crossing signals and, thus, AC current was not achieved. This problem was solved in (Albea *et al.*, 2006) with the use of a double boost converter as was proposed in (Caceres and Barbi, 1999). A phase-lock loop was necessary for the correct operation of the circuit as well as for synchronization with the electrical grid. Only the case of known resistive load was considered. In (Albea *et al.*, 2007) unknown loads were considered using an adaptation mechanism.

The control law designed in (Albea *et al.*, 2006) does not achieve global stability due to two reasons: on one hand, the ideal control signal cannot

be implemented globally because of the saturation of the actual circuit. On the other hand, the circuit imposes physical constraints in some state variables –namely, the capacitor voltages cannot be negative. In this paper we deal with the problem of estimating the resultant region of attraction. This is a difficult problem due to the nonlinear character of both, the open-loop system and the control law, which is solved by Sums of Squares optimization (Prajna *et al.*, 2002).

The rest of the paper is organized as follows: in Sect. 2 the model of the double boost converter (boost inverter) is presented. Section 3 states the problem and Sect. 4 recalls the sum of squares optimization technique. In Sect. 5 this technique is used to solve the problem and Sect. 6 presents the conclusions.

2. BOOST INVERTER MODEL

The boost inverter is specially interesting because it generates an AC output voltage larger than the its DC input. This converter achieves DC-AC conversion. It is composed of two DC-DC converters and a load connected as shown in Fig. 1. Each converter produces a DC-biased sine wave output, V_1 and V_2 , so that each source generates

^{*} This research has been partially supported by the MCyT-FEDER grant DPI2006-07338.

an unipolar voltage. The circuit implementation is shown in Fig. 2. Voltages V_1 and V_2 should present a phase shift equal to 180° , which maximizes the voltage excursion across the load (Caceres and Barbi, 1999).

It is here assumed that:

- all the components are ideal and the currents of the converter are continuous,
- the inductances $L_1 = L_2$, and the capacitances $C_1 = C_2$, are known and symmetric.

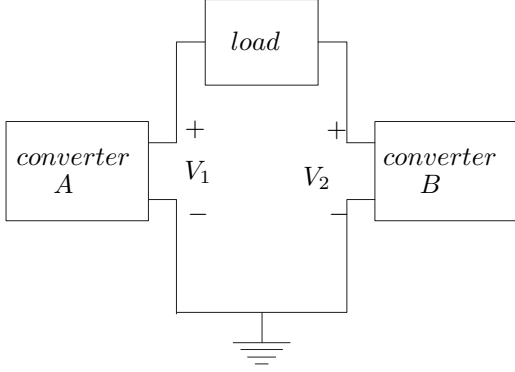

Fig. 1. Basic representation of the boost inverter.

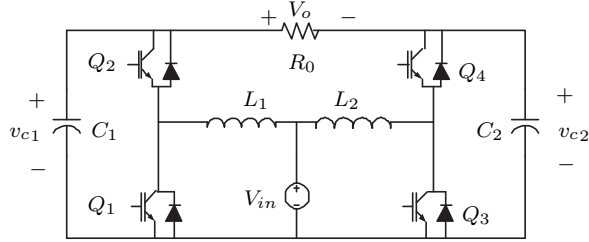

Fig. 2. Ideal Boost DC-AC Converter.

The circuit in Fig. 2 is driven by the transistor ON/OFF inputs Q_i . This yields four modes of operations as illustrated in Fig. 3. Following (Albea *et al.*, 2006), the converter dynamic equation are

$$\begin{aligned} L_1 \frac{di_{L1}}{dt} &= -u_1 v_{c1} + V_{in} \\ C_1 \frac{dv_{c1}}{dt} &= u_1 i_{L1} - \frac{v_{c1}}{R} + \frac{v_{c2}}{R} \\ L_2 \frac{di_{L2}}{dt} &= -u_2 v_{c2} + V_{in} \\ C_2 \frac{dv_{c2}}{dt} &= u_2 i_{L2} + \frac{v_{c1}}{R} - \frac{v_{c2}}{R} \end{aligned}$$

As usual, we consider an averaged model described in terms of the mean currents and voltages values. Hence, u_1 and u_2 , which reflect the mean duty-cycle activation percent of each circuit, are regarded continuous variables, $u_i \in [0, 1]$, $i = 1, 2$, being more suited for control because it is described by a ‘‘continuous’’ time smooth and nonlinear ODE by using the following change of variables

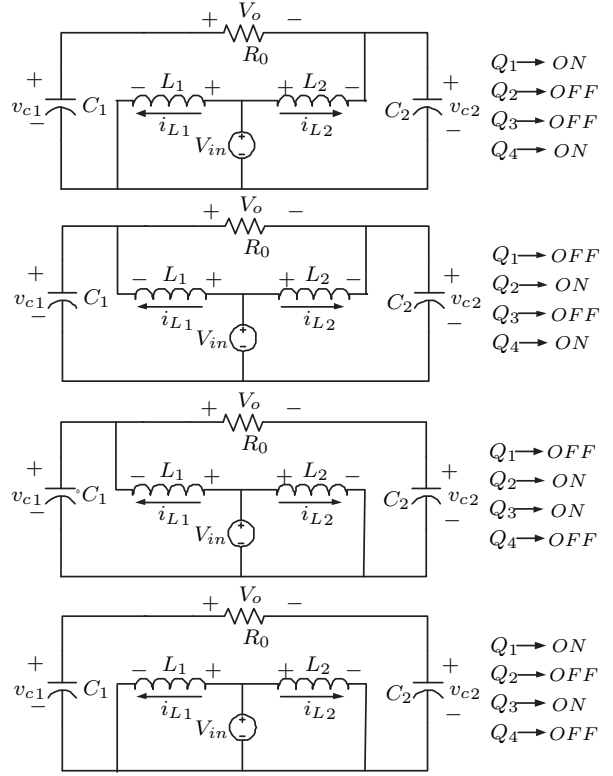

Fig. 3. Operation modes

$$x_1 = \frac{1}{V_{in}} \sqrt{\frac{L_1}{C_1}} i_{L1} \quad (1)$$

$$x_2 = \frac{v_{C1}}{V_{in}} \quad (2)$$

$$x_3 = \frac{1}{V_{in}} \sqrt{\frac{L_1}{C_1}} i_{L1} \quad (3)$$

$$x_4 = \frac{v_{C1}}{V_{in}} \quad (4)$$

and defining

$$\tilde{t} = \frac{1}{\sqrt{L_1 C_1}} t \quad (5)$$

This averaging process yields the normalized model described next.

2.1 Normalized averaged Model

A normalized model, in terms of the averaged current x_1 , x_3 and the averaged voltage x_2 , x_4 is:

$$\dot{x}_1 = -u_1 x_2 + 1 \quad (6)$$

$$\dot{x}_2 = u_1 x_1 - a x_2 + a x_4 \quad (7)$$

$$\dot{x}_3 = -u_2 x_4 + 1 \quad (8)$$

$$\dot{x}_4 = u_2 x_3 + a x_2 - a x_4 \quad (9)$$

where u_1 and u_2 are treated as continuous variables and a is defined as $a = \frac{1}{R_0} \sqrt{\frac{L_1}{C_1}}$. R_0 may be known (Albea *et al.*, 2006) or unknown (case of adaptive control (Albea *et al.*, 2007)).

3. PROBLEM FORMULATION

In (Albea *et al.*, 2006) a control law was designed for system (6)–(9) in order to make the output y to oscillate as a sinusoidal signal with a given amplitude i.e.

$$y = x_2 - x_4 \quad \rightarrow \quad y_r = A \cos(\omega t + \varphi)$$

with a pre-specified value for A , and ω . The phase shift φ is no specified.

Under the assumption that a is constant and known, in (Albea *et al.*, 2006) a nonlinear control law based on Hamiltonian approach was proposed. The design is based on the following change of coordinates:

$$\eta_1 = \frac{x_1^2 + x_2^2}{2} \quad (10)$$

$$\eta_2 = x_1 - ax_2^2 + ax_2x_4 + \eta_{20} \quad (11)$$

$$\eta_3 = \frac{x_3^2 + x_4^2}{2} \quad (12)$$

$$\eta_4 = x_3 - ax_4^2 + ax_2x_4 + \eta_{40} \quad (13)$$

The aim of the control design is to render the following functions

$$\Gamma_1 = \omega^2(\eta_1 - \eta_{10})^2 + (\eta_2 - \eta_{20})^2 - \mu$$

$$\Gamma_2 = \omega^2(\eta_3 - \eta_{30})^2 + (\eta_4 - \eta_{40})^2 - \mu$$

tend to zero. These goals describe two ellipses in the current-voltage plane. η_{10} , η_{20} and η_{30} , η_{40} are the respective centers and ω , μ are related to their size. These parameters can be computed from the desired output behavior. Based on this definition, the nonlinear control law as proposed in (Albea *et al.*, 2006) has the following form:

$$u_1 = \frac{1 + 2a^2x_2^2 - 3a^2x_2x_4 + a^2x_4^2 + ax_2\dot{x}_4}{x_2 + 2ax_1x_2 - ax_4x_1} + \frac{k\Gamma_1(\eta_2 - \eta_{20}) + \omega^2(\eta_1 - \eta_{10})}{x_2 + 2ax_1x_2 - ax_4x_1} \quad (14)$$

$$u_2 = \frac{1 + 2a^2x_4^2 - 3a^2x_2x_4 + a^2x_2^2 + ax_4\dot{x}_2}{x_4 + 2ax_3x_4 - ax_2x_3} + \frac{-k\Gamma_2(\eta_4 - \eta_{40}) + \omega^2(\eta_3 - \eta_{30})}{x_4 + 2ax_3x_4 - ax_2x_3} \quad (15)$$

The design is completed with an additional outer loop (PLL) that has the function of synchronize the phase shift of 180° between the two voltages V_1 , and V_2 reaching in that way the desired objective.

In (Albea *et al.*, 2006) it is proved that, with this control law, for all initial conditions except the origin the trajectories of the resultant system tend to the curve $\Gamma_i = 0$; $i = 1, 2$. Nevertheless, there exist several constraints in the state variable that make this analysis useless from the practical point of view. These constraints are of several types:

- C1. Constraints $0 \leq u_i \leq 1$; $i = 1, 2$ makes control law (14)–(15) not to be feasible in the full state space. In practice $u_i = 1$ when the above expressions give values greater than 1 and, on the contrary, $u_i = 0$ when the expressions give negative value. This constraint is soft in the following sense: if the system arrives at a point where the constraints are violated, the analysis of (Albea *et al.*, 2006) is not longer valid for the system with constraints, but this point might be in the attraction domain of the desired limit cycle.
- C2. Capacitor voltages cannot be negative in this circuit, which implies $x_i \geq 0$; $i = 2, 4$. This is a hard constraint since this situation should be avoided.
- C3. Finally, control law is not feasible when any of the denominators in (14)–(15) is zero. Really, this constraint is contained in the previous one, since denominators close to zero would imply large (positive or negative) values for u .

The objective of this paper is to obtain a (possibly conservative) estimation for the region of attraction of the resultant system taking into account these physical constraints.

4. SUM OF SQUARES OPTIMIZATION

Sum of squares optimization is an optimization technique based on the sum of squares decomposition for multivariate polynomials. A multivariate polynomial $p(x)$ is said to be a sum of squares (SOS) if there exist polynomials $f_1(x), \dots, f_m(x)$, such that

$$p(x) = \sum_{i=1}^m f_i^2(x)$$

and therefore, $p(x) \geq 0$ (Prajna *et al.*, 2004).

A sum of squares (SOS) program has the form (Prajna *et al.*, 2004):

Minimize the linear objective function

$$w^T c,$$

where c is a vector formed from the (unknown) coefficients of:

- polynomials $p_i(x)$, for $i = 1, 2, \dots, N_1$
- sum of squares $p_i(x)$, for $i = N_1 + 1, \dots, N_2$

such that

$$a_{0,j}(x) + \sum_{i=1}^N p_i(x)a_{i,j}(x) = 0 \quad \text{for } j = 1, 2, \dots, M_1.$$

$$a_{0,j}(x) + \sum_{i=1}^N p_i(x)a_{i,j}(x) \text{ are SOS,} \quad \text{for } j = M_1 + 1, \dots, M_2.$$

where w is the vector of weighting coefficients of the linear objective function, and $a_{i,j}(x)$ are some scalar constant coefficient polynomials.

Currently, sum of squares programs are solved by reformulating them as semidefinite programs (SDPs), which in turn are solved efficiently e.g. using interior point methods. Several commercial as well as non-commercial software packages are available for solving SDPs. SOSTOOLS (Prajna *et al.*, 2002) is a Matlab toolbox that performs this conversion automatically and call the SDP solver, and converts the SDP solution back to the solution of the original problem.

5. ESTIMATION OF THE REGION OF ATTRACTION

The problem at stake can be considered to belong to the following class of problems:

Given a control system $\dot{x} = f(x, u)$ with constraints in both the state variables and the control input $g_x(x) \geq 0, g_u(u) \geq 0$. Assume that a control law $u = u(x)$ has been designed such that stability is proved when no constraints are taken into account. The problem is to estimate a region of attraction for the real system with constraints when this control law is applied.

Notice that the control objective is not necessarily stabilization of an equilibrium point, and that stabilization of limit cycles, as in our case, can be considered.

A further assumption will be adopted: stability for system with no constraints is assumed to be proved by LaSalle invariance principle.

Assumption 1. There exist a radially unbounded Lyapunov function $V(x)$ such that, inside a compact positively invariant set Ω , $\dot{V} \leq 0$ (for the unconstrained system). Let M be the largest invariant subset of the set for which $\dot{V} = 0$ in Ω .

By LaSalle invariance principle, this assumption guarantees that the trajectories of the unconstrained system tend to M . It is implicitly assumed that this is the desired behavior.

A (conservative) estimation for the attraction domain of the system with constraints is given by the following theorem

Theorem 1. Under the previous assumption, assume that there exists a constant $c > 0$ such that in the set $\Omega_c = \{x : V(x) \leq c\}$ all the constraints

are fulfilled. Then, all trajectories of the system with constraints starting at Ω_c tend to $M \cap \Omega_c$.

Proof Since in Ω_c the constraints are fulfilled, the results for the unconstrained system are valid in Ω_c . Therefore, $\dot{V} \leq 0$ in Ω_c and Ω_c is positively invariant. Furthermore, since $V(x)$ is radially unbounded Ω_c is compact. By applying LaSalle invariance principle the statement is proved. ■

Remark 1. Since $M \cap \Omega_c \subset M$ the theorem guarantees that the asymptotic behavior for the system with constraints is the desired one.

Remark 2. As other techniques for estimation of attraction domain, the present method is conservative. In this case is mainly due to two facts:

- The estimation of the region of attraction is restricted to surfaces of the form $V = c$.
- The method searches for points that do not violate the constraints. Nevertheless, there may be points of this type in the actual attraction domain.

Using Theorem 1, the problem reduces to find a value $c > 0$ such that for $V(x) < c$ we have $g_i \geq 0$, $i = 1, \dots, N$. When the system and the constraints are polynomial, we can raise the following SOS problem:

Maximize c
subject to:

$$(V(x) - c) + p_i(x)g_i(x) - \varepsilon_i \\ \text{are SOS; } i = 1, \dots, N, \quad (16)$$

where p_i are unknown SOS polynomials. The purpose of constraints (16) is the fulfillment of the hypothesis of Theorem 1 as is stated in the following. Notice that at the boundary of the set Ω_c , $V(x) = c$ and, thus, the above constraints reduce to $p_i(x)g_i(x) \geq \varepsilon_i > 0$. As polynomials p_i are SOS, points at the boundary of Ω_c fulfill the constraints $g_i(x) \geq 0$. Furthermore, at the interior of this set, $V(x) - c < 0$ and the constraint is also fulfilled. Polynomials p_i introduce more degree of freedom in order to increase the problem feasibility. Constants ε_i are pre-specified, small constants that are needed in order to avoid problems at the points where $p_i(x) = 0$. The introduction of parameters ε_i is a new source of conservatism.

5.1 Application to the boost inverter

In (Albea *et al.*, 2006) it is proved that, under no constraints, for all trajectories (except the one starting at the origin) of system (6)–(9) with control law (14)–(15) tend to the desired limit

cycle. The proof was based on LaSalle invariance principle. The Lyapunov function used is:

$$V = \frac{\Gamma_1^2}{2} + \frac{\Gamma_2^2}{2}. \quad (17)$$

The constraints are (only constraints C1 and C2 are presented here; constraint C3 will be discussed later):

- $u_i(x) \leq 1 \quad i = 1, 2$
- $u_i(x) \geq 0 \quad i = 1, 2$
- $x_2 \geq 0$
- $x_4 \geq 0$.

The expressions for u_1 and u_2 , which are given by (14) and (15) are not polynomial but rational functions. Nevertheless, writing them as quotient of polynomials $u_i(x) = n_i(x)/d_i(x)$ all the constraint can be formulated in standard form. By taking a value for x in the desired curve, it can be seen that $d_i(x) < 0, i = 1, 2$ in the domain of interest since, by continuity, in order d_i to become positive, it must vanish at some points and constraint C3 would be violated. Thus, as $u_i(x) \geq 0$ we have $n_i(x) \leq 0$ as well. Taking into account that d_i must be negative, the constraint $u_i(x) \leq 1$ yields $n_i(x) \geq d_i(x)$. In this way the constraints become:

- $n_i(x) - d_i(x) \geq 0 \quad i = 1, 2$
- $-n_i(x) \geq 0 \quad i = 1, 2$
- $x_2 \geq 0$
- $x_4 \geq 0$

Thus, the problem to solve is

$$\text{Minimize } (-c) \quad (18)$$

subject to:

$$(V(x) - c) + p_1(x)(n_1(x) - d_1(x)) - \varepsilon_1 \geq 0 \quad (19)$$

$$(V(x) - c) + p_2(x)(n_2(x) - d_2(x)) - \varepsilon_2 \geq 0 \quad (20)$$

$$(V(x) - c) - p_3(x)n_1(x) - \varepsilon_3 \geq 0 \quad (21)$$

$$(V(x) - c) - p_4(x)n_2(x) - \varepsilon_4 \geq 0 \quad (22)$$

$$(V(x) - c) + p_5(x)x_2 - \varepsilon_5 \geq 0 \quad (23)$$

$$(V(x) - c) + p_6(x)x_4 - \varepsilon_6 \geq 0 \quad (24)$$

Notice that constraint C3 is also imposed. Indeed, if $d_1(x) = 0$, then constraint (19) reads

$$V(x) - c \geq -p_1(x)n_1(x) + \varepsilon_1 > 0$$

This means that $d_1(x)$ cannot vanish in the domain $V(x) \leq c$. The same reasoning can be applied to $d_2(x)$ in (20).

When this methodology is used, the achieved result is not restricted to the case of known resistive load but it is also valid for the case of unknown resistive load when the adaptation mechanism proposed in (Albea *et al.*, 2007) is used. The

reason is that the stability proof for the latter case is based on two-time-scales decomposition where the inverter dynamics are slow compared with the adaptation dynamics. This implies that the region of attraction for the non-adaptive case is conserved when adaptation is used.

5.2 Results

In order to test the previous results, we consider the following circuit parameters: $V_{in} = 20V$, $R_0 = 100\Omega$, $L_1 = L_2 = 1.5mH$, $C_1 = C_2 = 100\mu F$. The desired output of the circuit is $V_{out} = 40 \sin 50t V$.

In order to obtain this voltage, the parameters are $a = 0.039$, $\omega = 0.121$, $A = 1$, $k = 1.2$ and $\eta_{20} = \eta_{40} = 0$. The ellipse parameters result according to (Albea *et al.*, 2006) are $\eta_{10} = \eta_{30} = 12.842$, $\mu = 0.37$.

The tuning parameters ε_i are chosen equal to 10^{-12} .

Software SeDuMi (Sturm, 1999) was used as the SDP solver under SOSTOOLS. The solution is obtained in approximately two hours in a PC (1.7 GHz Centrino): $c^* = 0.39003$.

This result is conservative as was pointed out in Remark 2. Nevertheless, taking into account the remarked limitations, the obtained value for c results to be close to the optimal value as it has been verified by simulations. Performing several tests, we have try to find points $x(0)$ for which the constraints are violated and, on the other hand, are close to the curve $V(x) = c^*$. One of the points found is

$$x(0) = (6.1, -0.2, 2.7, 2.7)^\top$$

for which the Lyapunov function gives a value of $V = 0.4206$, while the corresponding value for control signal u_1 is equal to 1.0049. As 0.39003 is not far from c^* we can consider that the previous estimation is a reasonable estimation of the form $V(x) = c$ for the domain of attraction (and without violating the constraints).

6. CONCLUSIONS

An estimation of the region of attraction is presented for a nonlinear boost inverter taking into consideration the physical system constraints. The method is based on the search for a Lyapunov level surface where the constraints are fulfilled. The problem is difficult due to the system and control-law nonlinearities. This problem can be put as a Sum of Squares optimization problem, for which good numerical tools are available.

This approach has general applicability to cases where stability proof for the unconstrained problem is available (by means of Lyapunov methods) and extension to the constrained case is desired. The closed-loop system needs to be polynomial or rational (nevertheless, there exist cases where SOS programming have been applied to trigonometrical and other terms (Papachristodoulou and Prajna, 2002)). Conservativeness of the method has also been discussed.

The usefulness of the method has been shown by means of an example for the boost inverter.

REFERENCES

- Albea, Carolina, Carlos Canudas de Wit and Francisco Gordillo (2007). Adaptive control of the boost DC-AC converter. In: *Submitted to the 2007 IEEE Multi-conference on Systems and Control (MSC)*.
- Albea, Carolina, Francisco Gordillo and Javier Aracil (2006). Control of the boost DC-AC converter by energy shaping.
- Caceres, RO and I. Barbi (1999). A boost DC-AC converter: analysis, design, and experimentation. *Power Electronics, IEEE Transactions on* **14**(1), 134–141.
- Gordillo, F., DJ Pagano and J. Aracil (2004). Autonomous oscillation generation in electronic converters. *Proceedings of the IEEE International Workshop on Electronics and System Analysis-IWESA'04*.
- Pagano, D. J., J. Aracil and F. Gordillo (2005). Autonomous oscillation generation in the boost converter. In: *Proceedings of the 16th IFAC World Congress*.
- Papachristodoulou, A. and S. Prajna (2002). On the construction of Lyapunov functions using the sum of squares decomposition. *Decision and Control, 2002, Proceedings of the 41st IEEE Conference on*.
- Prajna, S., A. Papachristodoulou and PA Parrilo (2002). Introducing SOSTOOLS: a general purpose sum of squares programming solver. *Proceedings of the 41st IEEE Conference on Decision and Control*.
- Prajna, Stephen, Antonis Papachristodoulou, Peter Seiler and Pablo A. Parrilo (2004). *SOSTOOLS, Sum of Squares Optimization Toolbox for MATLAB*. available from <http://www.cds.caltech.edu/sostools>.
- Sturm, J.F. (1999). Using SeDuMi 1.02, a MATLAB toolbox for optimization over symmetric cones. *Optimization Methods and Software* **11–12**, 625–653. Special issue on Interior Point Methods (CD supplement with software).