



HAL
open science

Robust fault diagnosis for descriptor systems A coprime factorization approach

Benoît Marx, Damien Koenig, Didier Georges

► **To cite this version:**

Benoît Marx, Damien Koenig, Didier Georges. Robust fault diagnosis for descriptor systems A coprime factorization approach. Safeprocessl IFAC Fault Detection, Supervision and Safety of Technical Processes, 2003, Washington, United States. pp.CDROM. hal-00232846

HAL Id: hal-00232846

<https://hal.science/hal-00232846>

Submitted on 10 Mar 2023

HAL is a multi-disciplinary open access archive for the deposit and dissemination of scientific research documents, whether they are published or not. The documents may come from teaching and research institutions in France or abroad, or from public or private research centers.

L'archive ouverte pluridisciplinaire **HAL**, est destinée au dépôt et à la diffusion de documents scientifiques de niveau recherche, publiés ou non, émanant des établissements d'enseignement et de recherche français ou étrangers, des laboratoires publics ou privés.

ROBUST FAULT DIAGNOSIS FOR DESCRIPTOR SYSTEMS A COPRIME FACTORIZATION APPROACH

B. Marx, D. Koenig, D. Georges

*Laboratoire d'Automatique de Grenoble
B.P. 46, 38402 St Martin d'Hères, France
e-mail : benoit.marx@lag.inpg.fr*

Abstract : In this paper the factorization approach to robust residual generation is extended to descriptor systems. The design of the optimal residual generator for non causal systems is performed via two steps. First, the coprime factorization permits to use proper filters to perform the robust fault diagnosis. Secondly, the residual generation is considered as a special case of H_∞ -filtering. An LMI-based design of an optimal residual generator is proposed and illustrated.

Keywords : Fault diagnosis, Descriptor systems, Coprime factorization, Robustness.

1. INTRODUCTION

The descriptor form (*i.e.* $E \cdot dx/dt = Ax + \dots$) is much more general than the usual state-space representation for linear dynamic systems (*i.e.* $dx/dt = Ax + \dots$). This representation enables to take into account physical constraints, static relations and impulsive behaviors due to an improper part of the system. Thus descriptor systems appear in many fields of system design and control and an important literature is devoted to descriptor systems since (Lewis, 1986; Dai, 1989). Many topics of control have been extended to singular systems, such as LQ regulation (Cobb, 1983), H_2 -control (Takaba and Katayama, 1996), H_∞ -control (Takaba *et al.*, 1994) or LMI-based controllers (Masubuchi *et al.*, 1997).

Since two decades one of the most challenging problem is to ensure a safe and reliable control for dynamic systems faced to failures and despite of exogenous signals (Chen and Patton, 1999; Patton *et al.*, 2000). Concerning the descriptor systems few efforts have been made in fault detection and isolation (FDI), mainly developing fault detection based on observers (Chap.5 of Patton *et al.*, 2000) and unknown input observers (Duan *et al.*, 1999).

In this paper the coprime factorization is used to parameterize all proper residual generators for

descriptor plants affected by faults and disturbances. An optimal residual generator is synthesised to maximize the sensitivity to the faults while minimizing the sensitivity to the disturbances.

The paper is organized as follows. Section 2 recalls some useful concepts concerning the descriptor systems. In section 3 states some results on factorization for descriptor systems, ensuring the properness of the factors. Robust residual generation is tackled in section 4. An LMI-based design of the optimal proper residual generator is proposed. Section 5 presents an example of fault diagnosis.

2. PROBLEM STATEMENT

Let consider a stable linear time-invariant descriptor system subject to failures and disturbances given by

$$\begin{cases} E\dot{x}(t) = Ax(t) + Bu(t) + R_1 f(t) + E_1 d(t) \\ y(t) = Cx(t) + Du(t) + R_2 f(t) + E_2 d(t) \end{cases} \quad (1)$$

where $x \in R^n$ is the descriptor variable, $u \in R^{n_u}$ is the control input, $y \in R^m$ is the measured output, $d \in R^{n_d}$ is the disturbance, $f \in R^{n_f}$ is the failure and $E, A, B, C, D, E_1, E_2, R_1$ and R_2 are known real constant matrices with compatible dimensions. As discussed in (Frank and Ding, 1994), the unknown vector $d(t)$ in the equations (1) embraces model uncertainties, additive

perturbation, input and output multiplicative perturbation and the vector $f(t)$ stands for dysfunctions, actuator or sensor failures.

The matrix E may be rank deficient : $\text{rank}(E) = r \leq n$. The system (1) has a unique solution, for any initial condition, if it is regular (i.e. $\det(sE-A) \neq 0$). Let $q = \text{deg}(\det(sE-A))$, (1) has q finite dynamic modes, $(n-r)$ static modes and $(r-q)$ impulsive modes. The finite modes correspond to the finite eigenvalues of the pencil matrix (E, A) . The system is called stable if the finite modes are stable, i.e. if the finite eigenvalues of (E, A) lie in the open left half-plane. The impulsive modes may cause impulse terms in the response and thus are highly undesirable. A system has no impulsive mode and is said to be impulse free if and only if

$$\text{deg}(\det(sE - A)) = \text{rank } E \quad (2)$$

Since the transfer matrix of any impulse free descriptor system is (non strictly) proper it can be realized by an usual state-space representation (A, B, C, D) .

A descriptor system is impulse observable (resp. R -observable) if and only if it satisfies (3) (resp. (4))

$$\text{rank} \begin{bmatrix} E^T & 0 & 0 \\ A^T & E^T & C^T \end{bmatrix} = n + \text{rank } E \quad (3)$$

$$\text{rank} \begin{bmatrix} sE - A \\ C \end{bmatrix} = n, \forall s \text{ complex} \quad (4)$$

If (3) is verified, there exists a matrix gain L such that the pencil matrix $(E, A+LC)$ is impulse free. If (4) is verified the finite eigenvalues of $(E, A+LC)$ can be arbitrarily placed by the matrix gain L . Dual notions are defined for the controllability (Dai, 1989). If (E, A) is stable and impulse free, it is called admissible.

Assumption 1. (E, A, C) is impulse observable.

It is frequently claimed that considering both descriptor case and disturbance is redundant since the state can be augmented with d , but this approach gives rise to a more restrictive condition to verify the impulse observability of the augmented system.

3. COPRIME FACTORIZATION OF DESCRIPTOR SYSTEMS

Factorization techniques have been extensively treated not only for usual dynamic systems, using polynomial approach (Gao and Antsaklis, 1989) or state space approach (Clements, 1993), but also for descriptor systems (Liu *et al.*, 1997). This section presents a factorization for singular plants ensuring proper and stable factors by solving a strict LMI.

A double coprime factorization of a transfer function $G(s)$ is defined by

$$G(s) = \underline{N}(s) \underline{M}^{-1}(s) = M^{-1}(s) N(s) \quad (5)$$

where $\underline{N}(s)$, $\underline{M}(s)$, $M(s)$ and $N(s)$ are right and left coprime matrices of $G(s)$ respectively. Since the LTI descriptor system (1) can also be described by

$$y(s) = G_u(s)u(s) + G_f(s)f(s) + G_d(s)d(s) \quad (6)$$

$$\text{with } G_u(s) = \left\{ E, \begin{pmatrix} A & B \\ C & D \end{pmatrix} \right\}, G_d(s) = \left\{ E, \begin{pmatrix} A & E_1 \\ C & E_2 \end{pmatrix} \right\} \quad (7)$$

$$\text{and } G_f(s) = \left\{ E, \begin{pmatrix} A & R_1 \\ C & R_2 \end{pmatrix} \right\}$$

thus it can be factorized using the following theorem.

Theorem 1. Suppose $G(s)$ is a (non necessarily proper) real-rational matrix and

$$G(s) = \left\{ E, \begin{pmatrix} A & B \\ C & D \end{pmatrix} \right\} \quad (8)$$

is a regular, impulse observable and impulse controllable realization. Let L and F be such that $(E, A+LC)$ and $(E, A+BF)$ are impulse free, then $\underline{N}(s)$, $\underline{M}(s)$, $N(s)$ and $M(s)$ are given by

$$N(s) = \left\{ E, \begin{pmatrix} A+LC & B+LD \\ C & D \end{pmatrix} \right\}, M(s) = \left\{ E, \begin{pmatrix} A+LC & L \\ C & I \end{pmatrix} \right\}$$

$$\underline{N}(s) = \left\{ E, \begin{pmatrix} A+BF & B \\ C+DF & D \end{pmatrix} \right\}, \underline{M}(s) = \left\{ E, \begin{pmatrix} A+BF & B \\ F & I \end{pmatrix} \right\} \quad (9)$$

Proof. The proof is achieved by verifying (5) ■

The factorization parameters F and L must be determined such that the left and right coprime matrices of $G(s)$ are admissible. It is important to note that in that case $\underline{N}(s)$, $\underline{M}(s)$, $M(s)$ and $N(s)$ are stable and proper transfer matrices. Only $\underline{M}^{-1}(s)$ and $M^{-1}(s)$ may present impulsive terms.

Lemma 1 (Uezato and Ikeda, 1999) gives a method to compute L (and F by duality) by solving an LMI.

Lemma 1. The matrix pencil $(E, A+LC)$ is admissible if and only if there exist a positive definite matrix $P \in \mathbb{R}^{n \times n}$ and matrices $S \in \mathbb{R}^{(n-r) \times (n-r)}$, $T \in \mathbb{R}^{m \times n}$ and $H \in \mathbb{R}^{m \times (n-r)}$ satisfying the LMI (11). L is given by (12)

$$A^T (PE + VSU^T) + (PE + VSU^T)^T A + \dots C^T (TE + HU^T) + (TE + HU^T)^T C < 0 \quad (11)$$

$$L = (PE + VSU^T)^{-T} (TE + HU^T)^T \quad (12)$$

where U and V are full column-rank matrices spanning the null spaces of E and E^T respectively.

In the remaining L denotes a solution of (11)-(12)

4. ROBUST FAULT DIAGNOSIS

The objective of the fault diagnosis process is to build a signal, called residual, which highlights the appearance of a faulty behaviour. The mathematical definition of a residual signal is

$$\lim_{t \rightarrow \infty} r(t) = 0 \text{ for } f(t) = 0, d(t) = 0$$

$$r(t) \neq 0 \text{ for } f(t) \neq 0 \quad (13)$$

4.1 Residual generation

Following the procedure of (Frank and Ding, 1994), the left coprime factorization of $G_u(s)$ is used to generate a primary residual $\underline{r}(s)$ only affected by the failures $f(s)$ and the disturbances $d(s)$. A second step consists in filtering the primary residual to minimize the transfer from $d(s)$ to the residual.

Since (E, A, C) is impulse observable, the transfer matrices $G_u(s)$, $G_d(s)$ and $G_f(s)$ are factored by

$$\begin{aligned} G_u(s) &= M^{-1}(s)N_u(s) \\ G_d(s) &= M^{-1}(s)N_d(s) \\ G_f(s) &= M^{-1}(s)N_f(s) \end{aligned} \quad (14)$$

$$\begin{aligned} \text{where } M(s) &= \left\{ E, \begin{pmatrix} A+LC & L \\ C & I \end{pmatrix} \right\} (m \times m) \\ N_u(s) &= \left\{ E, \begin{pmatrix} A+LC & B+LD \\ C & D \end{pmatrix} \right\} (m \times nu) \\ N_d(s) &= \left\{ E, \begin{pmatrix} A+LC & E_1+LE_2 \\ C & E_2 \end{pmatrix} \right\} (m \times nd) \\ N_f(s) &= \left\{ E, \begin{pmatrix} A+LC & R_1+LR_2 \\ C & R_2 \end{pmatrix} \right\} (m \times nf) \end{aligned} \quad (15)$$

where L is computed by solving the LMI (11). The residual generator is deduced from (14) and (15)

$$\begin{aligned} \underline{r}(s) &= M(s)y(s) - N_u(s)u(s) \\ &= N_f(s)f(s) + N_d(s)d(s). \end{aligned} \quad (16a)$$

$$\begin{aligned} r(s) &= Q(s)\underline{r}(s) \\ &= Q(s)(N_f(s)f(s) + N_d(s)d(s)) \end{aligned} \quad (16b)$$

where $Q(s)$ is a stable and proper filter of order nq defined by

$$Q(s) = \begin{pmatrix} A_Q & B_Q \\ C_Q & D_Q \end{pmatrix} (nr \times m) \quad (17)$$

Since $(E, A+LC)$ is admissible, the finite modes of $N_f(s)$ decay exponentially and thus, according to (13), $\underline{r}(s)$ is a residual signal. Applying standard H_∞ techniques, a post filter $Q(s)$ is synthesized to enhance the robustness faced to the unknown inputs $d(s)$ and to shape the response of the residual generator.

4.2 Parameterization of all the residual generators

According to (15) and (16) the residual generator is parameterized by L and the post-filter $Q(s)$. Theorem 2 proves that the residual generator is independent of the factorization parameter L (this can be considered as a generalization of the result established by Ding and Guo (1997))

Theorem 2. Given two factorizations of a real-rational transfer matrix $G(s)$

$$G(s) = M_1^{-1}(s)N_1(s) = M_2^{-1}(s)N_2(s) \quad (18)$$

$$\text{where } M_i(s) = \left\{ E, \begin{pmatrix} A+L_iC & L_i \\ C & I \end{pmatrix} \right\} \text{ and}$$

$$N_i(s) = \left\{ E, \begin{pmatrix} A+L_iC & B+L_iD \\ C & D \end{pmatrix} \right\}, \text{ for } i=1,2.$$

where L_i ensures that $M_i(s)$ and $N_i(s)$ are admissible for $i=1,2$, there exists a stable $Q_0(s)$ which satisfies

$$Q_0(s)M_1(s) = M_2(s) \quad (19a)$$

$$Q_0(s)N_1(s) = N_2(s) \quad (19b)$$

and furthermore $Q_0(s)$ is given by

$$Q_0(s) = \left\{ E, \begin{pmatrix} A+L_2C & L_2-L_1 \\ C & I \end{pmatrix} \right\} \quad (20)$$

Proof. The proof is achieved by verifying (18) ■

As a result of theorem 1, the performance of the residual generation is independent of the choice of L . Any possible performance can be achieved by designing $Q(s)$ for a given L_0 .

Corollary 1. Assuming that the matrix L_0 ensures the admissibility of $(E, A+L_0C)$, then all the residual generators can be parameterized by

$$r(s) = Q(s)(M_0(s)y(s) - N_0(s)u(s)) \quad (21)$$

$$r(s) = Q(s)M_0(s)(G_d(s)d(s) + G_f(s)f(s)) \quad (22)$$

$$\text{where } M_0(s) = \left\{ E, \begin{pmatrix} A+L_0C & L_0 \\ C & I \end{pmatrix} \right\}$$

$$\text{and } N_0(s) = \left\{ E, \begin{pmatrix} A+L_0C & B+L_0D \\ C & D \end{pmatrix} \right\}$$

4.3 Synthesis of the optimal residual generator

Since perfect FDI –where each component of the residual vector is non null if and only if the corresponding fault has occurred- is a very restrictive case, residual generators need to be optimal regarding to a criterion to define. Roughly speaking the objective is to make the residual sensitive to $f(s)$ while insensitive to $d(s)$. A natural approach is to maximize the following criterion

$$J = \frac{\|Q(s)N_f(s)\|}{\|Q(s)N_d(s)\|} \quad (23)$$

where $\|\cdot\|$ denotes a matrix norm. Choosing the L_2 norm, this problem can be solved via a generalized eigenvalue / eigenvector problem (Frank and Ding, 1997). Choosing the L_∞ norm is a more generic approach since no assumption need to be made on the power spectrum of $f(s)$ and $d(s)$ excepted their finite energy. This optimization problem have been treated by Frank and Ding (1994, 1997) for usual systems.

This contribution is based on the standard H_∞ filtering approach to robust residual generation, treated by Edelmayer *et al.* (1994) for the usual systems.

The objective is to find the $Q(s)$ which minimizes the following performance index

$$J = \|G_{rv}(s) - [0 \ T(s)]\|_\infty \quad (24)$$

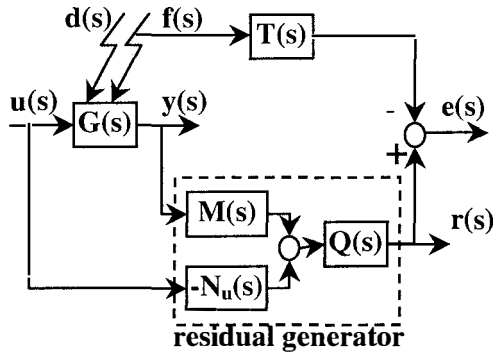

Fig 1. Scheme of robust residual generation.

where G_{rw} is the transfer from $w(s)=[d^T(s) f^T(s)]^T$ to $r(s)$. $T(s)$ is a filtering parameter which allows to take advantage of the available knowledge concerning the faults, for instance by amplifying a frequency range where the faults are expected or filtering by a diagonal of low-pass filter when the estimated faults are used for reconfiguration. The objective is to minimize the transfer from $w(s)$ to $e(s)=r(s)-T(s)f(s)$ by choosing the appropriate post filter $Q(s)$ as shown on figure 1.

Since $N_d(s)$ and $N_f(s)$ are admissible, by a singular value decomposition of E , they can be realized using stable usual state-space systems of order $r=\text{rank } E$

$$G_{rw}(s) = Q(s) \begin{bmatrix} N_d(s) & N_f(s) \end{bmatrix} = \begin{pmatrix} A_Q & B_Q \\ C_Q & D_Q \end{pmatrix} \begin{pmatrix} \underline{A} & \begin{bmatrix} E_1 & R_1 \end{bmatrix} \\ \underline{C} & \begin{bmatrix} E_2 & R_2 \end{bmatrix} \end{pmatrix} \quad (25)$$

The following theorems give a method to design the post-filter $Q(s)$ for a given stable $T(s)$, of order nt defined by

$$T(s) = \begin{pmatrix} A_T & B_T \\ C_T & D_T \end{pmatrix} \quad (26)$$

The objective (24) can be re-formulate as finding the controller $Q(s)$ that minimizes the H_∞ norm of the transfer from $w(s)$ to $e(s)$, in other words finding the controller $Q(s)$ that satisfies (27) for a given real positive γ chosen as small as possible

$$\|T_{ew}(s)\|_\infty = \|G_{rw}(s) - [0 \ T(s)]\|_\infty < \gamma \quad (27)$$

$T_{ew}(s)$ is given by the interconnection of a plant (28) and a controller (29). In the standard H_∞ framework, $e(s)$ is the controlled output, $r(s)$ is the measured output, $w(s)$ gathers the exogenous signals and $r(s)$ is the control input

$$\begin{pmatrix} e(s) \\ r(s) \end{pmatrix} = \begin{pmatrix} A_d & B_{1d} & B_{2d} \\ C_{1d} & D_{11d} & D_{12d} \\ C_{2d} & D_{21d} & 0 \end{pmatrix} \begin{pmatrix} w(s) \\ r(s) \end{pmatrix} \quad (28)$$

$$r(s) = \begin{pmatrix} A_Q & B_Q \\ C_Q & D_Q \end{pmatrix} r(s) \quad (29)$$

$$\text{where } A_d = \begin{pmatrix} A_T & 0 \\ 0 & A \end{pmatrix}, B_{1d} = \begin{pmatrix} 0 & B_T \\ E_1 & R_1 \end{pmatrix}, B_{2d} = \begin{pmatrix} 0 \\ 0 \end{pmatrix}, \\ C_{1d} = (-C_T \ 0), C_{2d} = (0 \ \underline{C}), \\ D_{11d} = (0 \ -D_T), D_{12d} = I \text{ and } D_{21d} = (\underline{E}_2 \ \underline{R}_2)$$

The design of $Q(s)$ follows the LMI-based controller synthesis presented by Gahinet and Apkarian (1994). The conditions to be verified are the detectability and stabilizability of (A_d, B_{2d}, C_{2d}) , and a null direct transfer from $r(s)$ to $r(s)$. The former is secured since \underline{A} and A_T are stable. And the latter is verified in (28). The optimal achievable γ is determined by theorem 3 and theorem 4 gives the computation of the post-filter $Q(s)$.

Theorem 3. For a given positive number γ , a post filter $Q(s)$ satisfying (27) exists if and only if there exist R and S real symmetric $(nt+r) \times (nt+r)$ matrices such that the LMIs (30) hold

$$\begin{pmatrix} A_d R + R A_d^T & B_{1d} \\ B_{1d}^T & -\gamma I \end{pmatrix} < 0 \quad (30a)$$

$$\begin{pmatrix} N_S^T & 0 \\ 0 & I \end{pmatrix} \begin{pmatrix} A_d^T S + S A_d & S B_{1d} & C_{1d}^T \\ B_{1d}^T S & -\gamma I & D_{11d}^T \\ C_{1d} & D_{11d} & -\gamma I \end{pmatrix} \begin{pmatrix} N_S & 0 \\ 0 & I \end{pmatrix} < 0 \quad (30b)$$

$$\begin{pmatrix} R & I \\ I & S \end{pmatrix} \geq 0 \quad (30c)$$

where N_S is an orthonormal basis of the null space of $[C_{2d} \ D_{21d}]$.

In addition, γ is achievable by a $Q(s)$ of order $k < nt+r$ if and only if the LMIs (30) hold for some R, S which also satisfy

$$\text{Rank}(I + RS) \leq k \quad (31)$$

The optimal achievable γ_{opt} can be determined by a simple minimization of the LMI variable γ , under the constraint (30).

Theorem 4. Let (R, S) satisfy (30) for γ_{opt} . An optimally robust residual generator, satisfying (27), is determined by the post filter $Q(s)$ defined by

$$\Theta = \begin{pmatrix} A_Q & B_Q \\ C_Q & D_Q \end{pmatrix} \quad (32)$$

where Θ satisfies the LMI (33)

$$\begin{pmatrix} A_0^T X + X A_0 & X B_0 & C_0^T \\ B_0^T X & -\gamma I & D_0^T \\ C_0 & D_0 & -\gamma I \end{pmatrix} + P^T \Theta Q + Q^T \Theta^T P < 0 \quad (33)$$

$$\text{where } A_0 = \begin{pmatrix} A_T & 0 & 0 \\ 0 & \underline{A} & 0 \\ 0 & 0 & 0 \end{pmatrix}, B_0 = \begin{pmatrix} 0 & B_T \\ E_1 & R_1 \\ 0 & 0 \end{pmatrix}$$

$$C_0 = (-C_T \ 0 \ 0), D_0 = (0 \ -D_T) \\ P = \begin{pmatrix} (0 \ 0 \ I) X & 0 \ 0 \\ (0 \ 0 \ 0) X & 0 \ I \end{pmatrix}$$

$$Q = \begin{pmatrix} (0 \ 0 \ I) & 0 \\ (0 \ \underline{C} \ 0) & (\underline{E}_2 \ \underline{R}_2) \end{pmatrix}$$

$$X = \begin{pmatrix} S & N \\ N^T & -N R M (M^T M)^{-1} \end{pmatrix}$$

where M and N are full column rank matrices $\in \mathbf{R}^{(r+nt) \times nt}$ such that $M N^T = I - R S$

Proof. Derived from (Gahinet and Apkarian, 1994). ■

The design of a reduced order $Q(s)$ follows the same method with (R, S) also satisfying (31).

Algorithm of fault detection

Step1. Solve the LMI (11) to determine L such that the factorisation (14) is admissible.

Step2. Determine γ_{opt} by minimizing γ under the LMI constraint (30).

Step3. Compute the post-filter $Q(s)$ by solving the LMI (33).

From the classical H_∞ -control theory it is known that the order of $Q(s)$ is bounded by $nq \leq r+nt$. For implementation it is of interest to minimize nq by checking (31) for a decreasing k . If no satisfactory γ can be achieved for a reduced order $Q(s)$, the order of $T(s)$ can be decreased. The extreme case is fault estimation, where $T(s)$ has no dynamic.

4.4 Robust fault estimation.

The aim of the robust fault estimation is to find $Q(s)$ such that the residual signal $r(s)$ converges toward a linear combination of the faults. $Q(s)$ is chosen to satisfy (34) for a given real positive γ chosen as small as possible

$$\|Q(s)[N_d(s) N_f(s)] - [0 D_T]\|_\infty < \gamma \quad (34)$$

It can be considered as a special case of filtering, with $T(s)=D_T$, and can be addressed with the same machinery. Following theorems 3 and 4 respectively, theorem 5 gives the existence condition of $Q(s)$ and theorem 6 gives its computation.

Theorem 5. For a given positive number γ , a post filter $Q(s)$ satisfying (34) exists if and only if there exist R and S real symmetric ($r \times r$) matrices such that the LMIs (35) hold

$$\begin{pmatrix} \underline{A}R + R\underline{A}^T & B_{01} \\ B_{01}^T & -\gamma I \end{pmatrix} < 0 \quad (35a)$$

$$\begin{pmatrix} N_S^T & 0 \\ 0 & I \end{pmatrix} \begin{pmatrix} \underline{A}^T S + S\underline{A} & SB_{01d} & 0 \\ B_{01d}^T S & -\gamma I & D_{11d}^T \\ 0 & D_{11d} & -\gamma I \end{pmatrix} \begin{pmatrix} N_S & 0 \\ 0 & I \end{pmatrix} < 0 \quad (35b)$$

$$\begin{pmatrix} R & I \\ I & S \end{pmatrix} \geq 0 \quad (35c)$$

where $B_{01}=[\underline{E}_1 \underline{R}_1]$ and N_S is an orthonormal basis of the null space of $[\underline{C} \underline{E}_2 \underline{R}_2]$.

The optimal achievable γ_{opt} can be determined by a simple minimization of the LMI variable γ , under the constraint (35).

Theorem 6. Let (R,S) satisfy (35) for γ_{opt} . An optimally robust fault estimator is determined by the post filter $Q(s)$ satisfying (34), defined by

$$\Theta = \begin{pmatrix} A_Q & B_Q \\ C_Q & D_Q \end{pmatrix} \quad (36)$$

where Θ satisfies the LMI (37)

$$\begin{pmatrix} A_0^T X + XA_0 & XB_0 & 0 \\ B_0^T X & -\gamma I & D_0^T \\ 0 & D_0 & -\gamma I \end{pmatrix} + P^T \Theta Q + Q^T \Theta^T P < 0 \quad (37)$$

where $A_0 = \begin{pmatrix} \underline{A} & 0 \\ 0 & 0 \end{pmatrix}$, $B_0 = \begin{pmatrix} \underline{E}_1 & \underline{R}_1 \\ 0 & 0 \end{pmatrix}$, $D_0 = (0 - D_T)$

$$P = \begin{pmatrix} \begin{pmatrix} 0 & I \\ 0 & 0 \end{pmatrix} X & \begin{pmatrix} 0 & 0 \\ 0 & I \end{pmatrix} \\ \underline{C} & \begin{pmatrix} 0 & I \\ \underline{E}_2 & \underline{R}_2 \end{pmatrix} \end{pmatrix} \begin{pmatrix} 0 \\ 0 \end{pmatrix} \\ X = \begin{pmatrix} S & N \\ N^T & -NRM(M^T M)^{-1} \end{pmatrix}$$

where M and N are full column rank matrices $\in \mathbf{R}^{r \times nq}$ such that $MN^T = I - RS$. (38)

Remark. A post filter of reduced order $k < r$ can be synthesized by adding the constraint (31) to (35).

Algorithm of fault estimation

Step1. Solve the LMI (11) to determine L such that the factorisation (14) is admissible.

Step2. Determine γ_{opt} by minimizing γ under the LMI constraint (35).

Step3. Compute the post-filter $Q(s)$ by solving the LMI (37).

5. NUMERICAL EXAMPLE

In this section the algorithm of robust fault diagnosis is illustrated. Let consider the descriptor system (1) defined by

$$E = \begin{pmatrix} 1 & 0 & 0 & 0 \\ 0 & 1 & 0 & 0 \\ 0 & 0 & 0 & 1 \\ 0 & 0 & 0 & 0 \end{pmatrix} \quad A = \begin{pmatrix} -15 & 1 & 0 & 0 \\ 5 & -10 & 0 & 0 \\ 0 & 0 & 1 & 0 \\ 0 & 0 & 0 & 1 \end{pmatrix} \quad B = \begin{pmatrix} 1 & 0 \\ 0 & 0 \\ 0 & 0 \\ 0 & 1 \end{pmatrix} \\ R_1 = \begin{pmatrix} -1 & 0 \\ 0 & 0 \\ 0 & 0 \\ 0 & 0 \end{pmatrix} \quad E_1 = \begin{pmatrix} 0 & 0 \\ 1 & 0 \\ 0 & 0 \\ 0 & 0 \end{pmatrix} \quad C = \begin{pmatrix} 0 & 1 & 0 & 0 \\ 0 & 0 & 1 & 0 \end{pmatrix} \quad D = \begin{pmatrix} 0 & 0 \\ 0 & 0 \end{pmatrix} \\ R_2 = \begin{pmatrix} 0 & 0 \\ 0 & 1 \end{pmatrix} \quad E_2 = \begin{pmatrix} 0 & 1 \\ 0 & 0 \end{pmatrix} \quad (39)$$

where $d(t)$ and $f(t)$ are defined by (40) and (41) respectively. $f_1(t)$ is an actuator failure and $f_2(t)$ is a sensor offset

$$d_1(t) = 0.01 * \sin(300.t) \\ d_2(t) = 0.01 * \sin(200.t) \quad (40)$$

$$f_1(t) = \begin{cases} -u(t), & \text{for } 3 < t < 5 \\ 0, & \text{else} \end{cases} \\ f_2(t) = \begin{cases} 1, & \text{for } 7 < t < 9 \\ 0, & \text{else} \end{cases} \quad (41)$$

(E,A,C) is impulse observable but (E,A) is not impulse free.

First, L is determined such that $(E, A+LC)$ is admissible (impulse free and stable). Solving (11), $(E,A+LC)$ is impulse free and the finite eigenvalues are $\{-4.50 \pm 1.01i, -0.83\}$.

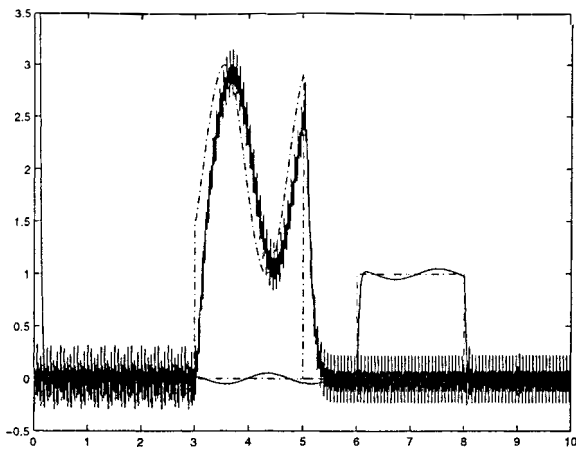

Fig. 2. Comparison of the faults (dashed lines) and residual signals (solid lines).

$T(s)$ is chosen to be a diagonal of first order low-pass filters. The minimization of γ results in $\gamma_{opt}=0.99$. An optimally robust post-filter $Q(s)$ of order $nq=5$ is determined by solving (31). The original and estimated faults are displayed on figure 2.

6. CONCLUSION

In this paper the design of an optimal residual generator for descriptor systems, formulated in the H_∞ control framework, was proposed and illustrated. The residual generator is synthesized by a two step procedure. Firstly, the residual generation is based on the coprime factorization of the plant. Since the resulting factors are not improper the residual generator can be realized by an usual state-space realization. Secondly, a post-filter is added to ensure the robustness of the fault diagnosis. The synthesis is based on the H_∞ -filtering approach.

As pointed in (Chen and Patton, 1999) it is not obvious to introduce model uncertainties in this formulation since $Q(s)$ is a post-filter and has no influence on the dynamics of the plant. Further works of interest should be to generalize the integrated control and fault detection investigated by Niemann and Stoustrup (1997).

ACKNOWLEDGMENT

This work is supported by the region Rhone-Alpes (France).

REFERENCES

- Chen, J. and R. J. Patton (1999). *Robust model-based fault diagnosis for dynamic systems*. Kluwer Academic Publishers.
- Clements, D.J. (1993). Rational spectral factorization using state-space methods. *Syst. Contr. Lett.*, **20**, 335-343.
- Cobb, D. (1983). Descriptor variable systems and optimal state regulation. *IEEE Trans. on Automatic Control*, **28**, 601-611.
- Dai, L. (1989). *Singular control systems*. Springer, Germany.
- Ding, X. and L. Guo (1997). On observer based fault detection, *Proc. of IFAC SAFEPROCESS'97*, 115-124.
- Duan, G.R., D. Howe and R.J. Patton (1999). Robust fault detection in descriptor linear systems via generalized unknown input observers. *Proc. of the 14th Triennial World Congress*, Beijing, P.R. China, CD-ROM.
- Edelmayer, A., J. Bokor and L. Keviczky (1994). An H_∞ filtering approach to robust detection of failures in dynamic systems, *Proc. of the 33rd Conf. on Decision and Control*, 3037-3039.
- Frank, P.M. and X. Ding (1994). Frequency domain approach to optimally robust residual generation and evaluation for model-based fault diagnosis. *Automatica*, **30**, 789-804.
- Frank, P.M. and X. Ding (1997). Survey of robust residual generation and evaluation methods in observer-based fault detection systems. *J. of Process Control*, **7**, 403-424.
- Gahinet, P and P. Apkarian (1994). A linear matrix inequality approach to H_∞ control. *Int. J. of Robust and Nonlinear Control*, **4**, 421-448.
- Gao, Z. and P.J. Antsaklis (1989). On stable solutions of the one- and two-sided model matching problems. *IEEE Trans. on Automatic Control*, **34**, 978-982.
- Lewis, F.L (1986). A Survey of linear singular systems. *Circuits Syst. & Signal Process*, **5**, 3-36.
- Liu, W.Q., W.Y. Yan and K.L. Teo (1997). A frequency domain approach to control of singular systems. *IEEE Trans. on Automatic Control*, **42**, 885-889.
- Masubuchi I., Y. Kamitane, A. Ohara and N. Suda (1997). H_∞ control for descriptor systems : a matrix inequalities approach, *Automatica*, **33**, 669-673.
- Niemann, H. and J. Stoustrup (1997). Integrating of control and fault detection : nominal and robust design. *Proc. of the IFAC SAFEPROCESS'97*, 331-336.
- Patton R.J., P.M. Frank and R.N. Clark (2000). *Issues of fault diagnosis for dynamical systems*. Springer, England.
- Takaba, K., N. Morihira and T. Katayama (1994). H_∞ -control for descriptor systems – a J-spectral factorization approach-. *Proc. of the 33rd Conf. on Decision and Control*, 2251-2256.
- Takaba, K. and T. Katayama (1996). H_2 optimal output feedback control for descriptor systems, *Proc. of the 35th Conf. on Decision and Control*, 1015-1020.
- Uezato, E. and M. Ikeda (1999). Strict LMI Conditions for Stability, Robust Stability, and H_∞ control of descriptor systems. *Proc. of the 24th IEEE Conf. on Decision and Control*, 4092-409.