



HAL
open science

Atomism and Binding

Hans Bennis, Pierre Pica, Johan Rooryck

► **To cite this version:**

Hans Bennis, Pierre Pica, Johan Rooryck. Atomism and Binding. Hans Bennis, Pierre Pica & Johan Rooryck. Foris Publications, pp.412, 1997, Pierre Pica. hal-00208029

HAL Id: hal-00208029

<https://hal.science/hal-00208029v1>

Submitted on 19 Apr 2017

HAL is a multi-disciplinary open access archive for the deposit and dissemination of scientific research documents, whether they are published or not. The documents may come from teaching and research institutions in France or abroad, or from public or private research centers.

L'archive ouverte pluridisciplinaire **HAL**, est destinée au dépôt et à la diffusion de documents scientifiques de niveau recherche, publiés ou non, émanant des établissements d'enseignement et de recherche français ou étrangers, des laboratoires publics ou privés.



Distributed under a Creative Commons Attribution - NonCommercial 4.0 International License

1 Atomism and Binding

Hans Bennis, Pierre Pica & Johan Rooryck (eds)

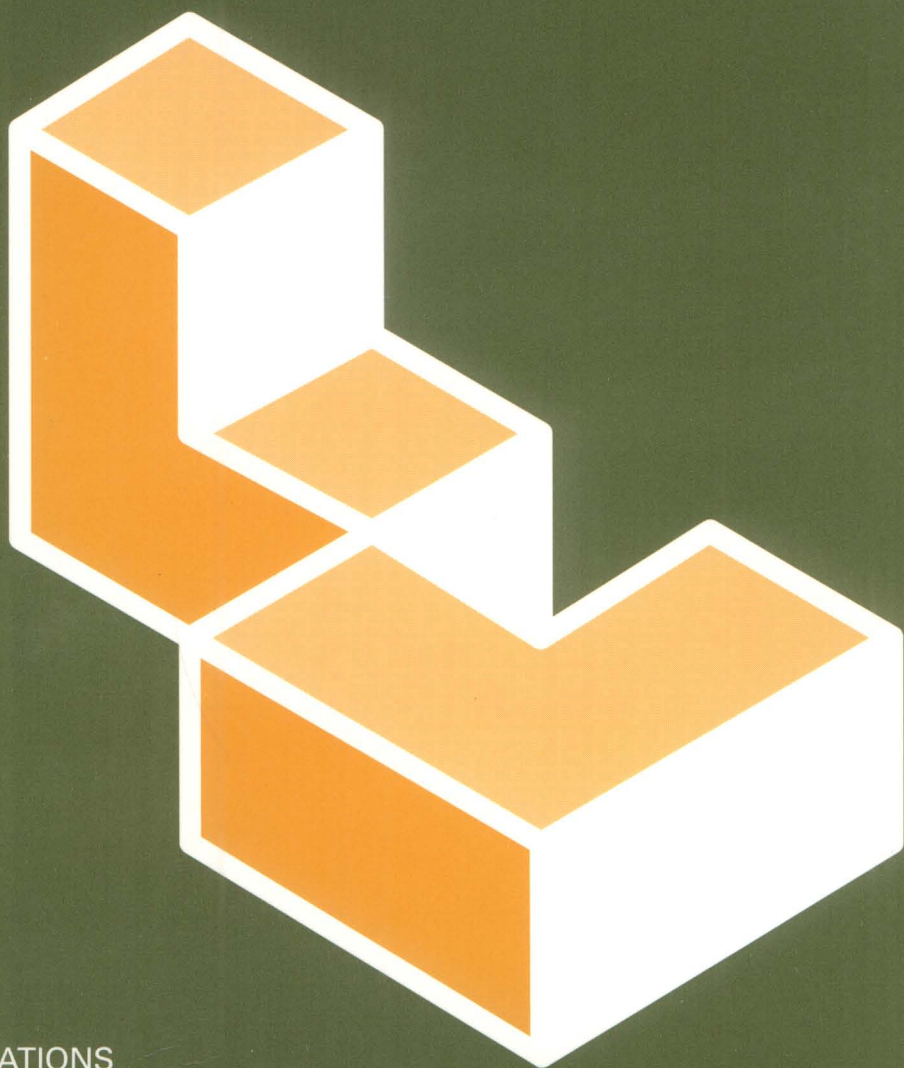

LINGUISTIC VARIATIONS

FORIS PUBLICATIONS

Atomism and Binding

Linguistic variations

The goal of this collection is to put at the disposal of the linguistic community studies which contribute to a deeper understanding of the nature of linguistic variation within the generative tradition that has been developing since the middle of the twentieth century.

The series will pay particular attention to the tension between descriptive and explanatory adequacy more accurately reformulated as a tension between the simplicity of the language faculty and its apparent complexity. Volumes will cover the traditional domain of syntactic studies, but will also include related areas such as semantics, morphology, phonology, and the lexicon. The series aims at distributing studies which constitute important contributions to the field, in particular to the domain of micro- and macro-variation.

The particular aim of the series is to publish both theoretical and empirical studies of language. Although the main focus of the series will be on generative linguistics, it will not exclude studies of a more general nature or from different schools of thought, insofar as they contribute to the advancement of the generative program.

Editorial board

Pierre Pica (CNRS, Paris)

Johan Rooryck (Leiden University)

Alain Rouveret (University of Paris VIII)

Esther Torrego (University of Massachusetts, Boston)

Advisory board

Paola Benincà, (University of Padova)

Noam Chomsky, (MIT, Cambridge Mass)

Guglielmo Cinque, (University of Venice)

Marcel Den Dikken, (Vrije Universiteit, Amsterdam)

Zygmunt Frajzyngier, (University of Colorado at Boulder)

Ken Hale, (MIT, Cambridge Mass)

Michael Kenstowicz, (MIT, Cambridge Mass)

Anders Holmberg, (Tromsø University)

Harry Van der Hulst, (Leiden University)

Yuki Kuroda, (Tohoku University)

Richard Larson (SUNY Stony Brook)

Vladimir Nedjalkov, (Academy of Sciences, St Petersburg)

Aryon Dall'igna Rodrigues, (Brasilia National University)

Atomism and Binding

Hans Bennis, Pierre Pica & Johan Rooryck (eds)



1997
FORIS PUBLICATIONS
Dordrecht - Holland

Published by:
Foris Publications Holland
P.O. Box 509
3300 AM Dordrecht, The Netherlands

ISBN 90 6765 535 X

© 1997 Foris Publications - Dordrecht

No part of this publication may be reproduced or transmitted in any form or by any means, electronic or mechanical, including photocopy, recording, or any information storage and retrieval system, without permission from the copyright owner.

Printed in The Netherlands by ICG Printing, Dordrecht.

Contents

Preface	i
1. Split Antecedents, Noncoreference, and DRT Stephen Berman & Arild Hestvik	1
2. Binding Theory and Switch-Reference George Aaron Broadwell	31
3. Condition C Hamida Demirdache	51
4. The Semantic Significance of Syntactic Identity Robert Fiengo & Robert May	89
5. Pronouns and Agreement: Systems Interaction in the Coding of Reference Zygmunt Frajzyngier	115
6. Binding Theory on Minimalist Assumptions Robert Freidin	141
7. A Configurational Approach to Thematic Binding Jeffrey S. Gruber	155
8. A Plea for Implicit Anaphors James Higginbotham	183
9. Sloppy Identity and Principle B Hajime Hoji	205
10. Anaphora and the Uniformity of Grammar Jan Koster	235

11. Levels of Representation and the Elements of Anaphora Howard Lasnik	251
12. On the Syntax of Local and Logophoric Control Seth A. Minkoff	269
13. Logical Entailment and the Possessive Nature of Reflexive Pronouns Gertjan Postma	295
14. Long Distance 'Binding' in Icelandic: Syntax or Discourse? Eric Reuland & Sigríður Sigurjónsdóttir	323
15. Symmetry and Unity in the Theory of Anaphora Ken Safir	341
16. Pronouns and Perspectives Chris Tancredi	381
Index of Languages	408
Index of Names	408
List of Authors	411

Preface: Perspectives on Binding and Atomism

Hans Bennis, Pierre Pica & Johan Rooryck

1 Introduction : 'internal' vs 'external' reference

A general assumption within generative theory is that the concept of *binding* is identifiable with a set of mechanisms and principles, specifically dealing with the distribution *and* interpretation of *definite descriptions*, *pronouns* and *reflexives*.¹ The aim of this introduction is to situate the articles contained in this volume, and to offer a perspective on the theoretical development of the various issues that are considered to be relevant to the study of binding. Hopefully, this will provide the reader with a background useful for understanding both the content and the scope of this volume.

Current issues in the theory of binding cannot be understood without keeping in mind the general goal of the generative enterprise. Although specific models differ in various ways, the leading ideas with respect to the main properties of the language faculty are remarkably constant since the pioneering work in the early fifties. In this early work (Chomsky 1951, 1955, 1975), a linguistic theory is explicitly defined as a model that consists of various levels of representation; a new abstract device was introduced in order to account for the complexity of language in an explanatory way. The concept of grammatical transformation was motivated as an attempt to solve the tension between descriptive and explanatory adequacy.

The approach of this early work gave rise to the factorization of linguistic objects in terms of subsystems of the linguistic model. Subsequent revisions of this type paved the way to an *atomic* theory of language. The general procedure by which a model is built out of various relatively independent submodules is referred to by the term

¹ In as far as empty positions can be reduced to one of the former categories, binding is also relevant to the theory of empty categories.

Atomism. This approach has led to a number of abstract entities, such as Deep Structure and Surface Structure, and to abstract subtheories applying to these levels of representation, such as Government, Subjacency, and *X'*-theory. In current thinking these abstract levels and submodules are suspected to be artefacts which can be derived from even more general abstract principles, some of which are related to formal conditions in terms of elegance, simplicity or economy (Chomsky 1995a). The search for such conditions, which might be considered equivalent to 'evaluation procedures', remained constant throughout the historical development of generative theory.

The language faculty is supposed to be an autonomous cognitive system. This view does not imply that it represents all the knowledge a language user needs to use his language. The language faculty interacts with other cognitive faculties. It is 'encapsulated' in the sense of Fodor (1983). In particular, the theory has to be embedded in a broader semiotic theory which makes use of the grammatical information to determine the 'meaning' and the 'reference' of expressions, and to guarantee an appropriate use of a particular linguistic object. As a result, there is no way to directly associate a syntactic object with a real world object. This is in opposition to what is generally argued in 'possible world semantics' and in most work on the philosophy of language.²

This state of affairs implies that we have to distinguish between those aspects of reference and/or meaning that are internal to the language faculty – 'internal reference' –, and aspects of reference/meaning that belong to other faculties of the mind/brain, or relate to the real world – 'external reference'. Aspects of 'external reference' may belong to pragmatics or discourse. Using slightly different terms, we have to make a distinction between grammar-dependent aspects of reference and object-dependent aspects – to use a terminology introduced by Vergnaud & Zubizarreta (1992) that can be traced back to Russell (1905). This factorization of reference has raised a lot of debate in linguistics, philosophy and cognitive science,³ as is also attested by various articles in this volume. This factorization can be viewed as an application of *Atomism* in the domain of Binding.

An example may clarify this issue. Take a simple sentence such as (1).

² Which is not to say that some phenomena alluded to within the philosophy of language cannot be restated in internalist terms, as several of the articles in this book suggest.

³ See the various articles in Rosenberg & Travis (1971). For more recent discussions, see Chomsky's reactions to Quine (1960, 1972), Kripke (1982), and Searle (1992) in Chomsky (1976b, 1986a, 1995b, 1996).

- (1) John took a book from the shelf and read it.

In this sentence the noun *book* is related to a lexical entry that contains information about properties of this noun such that the noun phrase *a book* can be understood as a mental object or a physical object in the real world. In this case we may assume that the second conjunct of (1) underlyingly contains a second occurrence of *a book* in object position. A transformational rule can be formulated that replaces the second occurrence of *a book* by *it* under referential identity with the object in the first conjunct. However, an approach like this is bound to fail given the existence of examples like (2), from Bach (1970), quoted in Jackendoff (1972).

- (2) The man who deserves it will get the prize he wants.

Examples like these clearly show that one cannot simply claim that a pronoun such as *it* is inserted by a transformation that replaces the constituent that it is coreferential with (*the prize he wants*), since it would lead to infinite recursion due to the fact that this latter constituent contains a pronoun (*he*) itself, as is shown in (3).

- (3) The man who deserves [the prize [the man who deserves [the prize [the man who deserves [the prize [the man

We thus need to distinguish between those aspects of reference that are grammar dependent, and those aspects that relate linguistic objects to non-linguistic entities either within the cognitive system, or in the 'real world'. This volume contains articles on both these perspectives.

Consequently, there are at least two ways to read this book. Some scholars will be interested in specific issues concerning binding proper and the relation of binding with other atoms of the grammar. Others may want to reach a better understanding of binding in the light of broader issues concerning the relation between grammar and the cognitive system, or between grammar and the outside world.

2 Nonintersecting reference and (non-)coreference

Since the mid-1960's, the emphasis of linguistic theorizing in generative grammar gradually shifted from structural descriptions and specific rules towards the formulation of general conditions constraining the mechanisms of the Grammar (Chomsky 1964, Ross 1967a). Binding did not escape this general tendency, as attested by the important work of Jackendoff (1972) who claimed that neither pronominalization nor reflexivization could be accounted for in terms of construction specific transformations.⁴

The investigation of what would later be called anaphoric relations has played an essential role in the process of reducing apparently unrelated constraints to more general conditions applying to various areas of the grammar. More in particular, the predominant view was that syntactic relations such as *each*-movement (cf. Dougherty 1969), NP-movement, *Wh*-movement, and interpretive phenomena including anaphoric relations of pronouns, were subject to the same locality conditions (Chomsky 1973).

All dependencies were to be treated by the interactions of two main conditions, the Specified Subject Condition (SSC) and the Tensed-S Condition (TSC). These general conditions were moreover constrained by a more general principle, the 'A-over-A' Principle.⁵ The TSC and the SSC also applied to a rule of interpretation (RI), reminiscent of Postal's 'Unlike Person Constraint' (Postal 1966, 1969). RI is a principle which seeks to interpret two NPs in a structure NP V NP as nonintersecting in reference. RI thus explains the deviance, (marked as '*' by Chomsky 1973) of the sentences in (4). RI also ensures that *he* and *him* in (5) are interpreted as different, and that *the officers* are not understood as being part of *the soldiers* who do the shooting in (6) (examples are from Chomsky 1973:241(42-44)).

- (4) a * I watched us leaving (in the mirror).
 b * I saw me.
- (5) He saw him.
- (6) The soldiers shot the officers (among them).

⁴ As opposed to the earlier accounts of Lees & Klima (1963), Ross (1967b) and Langacker (1969).

⁵ Interestingly, the A-over-A principle already contained the germ of the syntactic notions of 'cyclic node', 'subjacency' and 'containment', which all play a crucial role in further developments (see in particular Chomsky 1986b).

Chomsky (1973:241,fn.20) acknowledges in a footnote that this approach to nonintersecting reference among pronouns and noun phrases presupposes Helke's (1970) analysis of reflexives and inherent anaphora. Assuming Helke's analysis within this framework, it is the idiomatic nature of the possessive in (7a) which prevents RI from applying to it. Helke extends this analysis to (7b) by assuming that *himself* is analyzed as [*his self*].

- (7) a John lost his mind.
b John saw himself.

Chomsky (1976b:104, fn.35) explicitly analyzes *his* in (7a) as an anaphor, on a par with the reflexive in (7b), as opposed to *John lost his book* where *his* is a nonidiomatic pronoun.⁶ Fodor (1975:141-142) also argues in favor of the decomposition of *himself*, on the basis of a comparison of *himself* with what would later be called PRO (see also Castañeda 1966 for related ideas).

It can be observed that RI only has an indirect relation to the notion of coreference. It is a principle that ensures the nonintersecting interpretation of both pronouns and noun phrases, of which noncoreference is just a subcase. Importantly, Chomsky (1973) did not have a device ensuring direct coreference, as already pointed out by Lasnik (1976). In other words, while present-day Binding theory is constituted of distinct conditions on the coreference of reflexives (Condition A) and pronouns (Condition B), generative grammar of the early seventies only had a principle that looked like a predecessor of Condition B, to the extent that RI was subject to TSC and SSC. Significantly, there was no such predecessor for Condition A, with the possible exception of *each*-movement. Surprisingly then, the earliest stage of Binding theory was exclusively concerned with a rule of nonintersecting reference.

Moreover, since RI is subject to the locality restriction of TSC and SSC, it has nothing to say about a sentence such as (8b), which in present-day Binding theory is excluded by Condition C.

- (8) a John said that he would win. (John = he)

⁶ This morphological decomposition entails that bimorphemic anaphors can be considered an idiomatic type of pronoun, a position close to that of Kayne (1992). Interestingly, the issue of morphological complexity of anaphors was developed more thoroughly by Pica (1982, 1984a, 1985) and much subsequent work, e.g. Cole & Sung (1994), Postma (this volume), and various articles in Koster & Reuland (1991). See section 3.4.

- b *He said that John would win. (he =John)

Sentences (8a) and (8b) were indeed analyzed by Chomsky (1973:238,fn.16) as the result of a rule of Coreference Assignment, distinct from RI. Chomsky (1973, 1976a:324) claims that this type of rule does not belong to sentence grammar, but belongs to discourse (see also Lasnik 1976, and references therein).

A different view was developed in the late seventies inspired by influential work of Reinhart 1976, 1983a), which was adapted in part by Chomsky (1981). Reinhart observed that the grammar needs to deal with sentence (9), where, in contrast to (8), the pronoun is interpreted as a bound variable.

- (9) Every man said that he would win.
'For every x, x a man x said that x would win.'

Reinhart suggests that binding relations should be restricted to variable binding (see Reinhart (1976, 1983ab), and that binding relations should be established by sentence grammar in (9), and not in (8).

Every man in (9) has to c-command the pronoun in order to be interpreted as a bound variable. According to Reinhart, this is a stronger condition than the one which restricts pragmatic coreference, which requires only that the pronoun does not c-command the antecedent. Reinhart notes further that although sloppy identity involves a bound variable interpretation of the pronominal element, it is not restricted to a quantified antecedent, as illustrated by (10).

- (10) Charlie Brown talks to his dog and my neighbor Max does too.
(with the interpretation : 'Max talks to Max's dog.')

Following Keenan's (1971) and Partee's (1978) analysis of NPs, and Sag's (1976) and Williams' (1977) analysis of ellipsis, Reinhart argues that definite NPs can be introduced by a lambda operator and that a bound pronoun is interpreted as a bound variable, i.e. it is a pronominal whose coreference is grammatically determined, and in this sense comparable to a reflexive.

Reinhart's influential ideas are represented in various articles in this volume. This view distinguishes bound anaphora (belonging to the domain of sentence grammar) from pragmatic or intended reference. It amounts to saying that (8b) is not ruled out by principles of sentence grammar. This view gave rise to two important debates. First of

all, a discussion arose on the nature of the rule accounting for (8a), when the pronoun is not interpreted as a bound variable. Secondly, a debate developed on the nature of the rule that accounts for the ungrammaticality of (8b).^{7,8} This line of research led to further insights in what came to be called 'referential dependencies'.

3 Issues in the theory of Binding

3.1 Binding and (co)indexing

The conceptual and empirical problems mentioned in section 2 led to various lines of research. Chomsky's view first outlined in *On Binding* (Chomsky 1980) and further refined in *LGB* (Chomsky 1981) and *KoL* (Chomsky 1986a), involves various radical conceptual shifts. The notion of anaphor is introduced and defined as including both reflexives and NP-traces. Anaphors are bound in a self-contained domain, while pronouns are free in the same domain. Referential expressions are free throughout.

- (11) Condition A: anaphors are bound in their domain.
 Condition B: pronouns are free in their domain.
 Condition C: referential expressions are free.

The domain for anaphors and pronouns is defined in terms of Government (Chomsky 1981), or Complete Functional Complex (CFC) (Chomsky 1986a). In these approaches, the distribution of anaphors (Condition A) and pronouns (Condition B) is defined in a complementary fashion. This complementarity gave rise to a number of problems that played an important role in subsequent reformulations of the theory (see e.g. Reinhart & Reuland 1991, 1993). The notions 'bound' and 'free' are defined in terms of c-command and (co-)indexing.

The specific formulation of Binding theory from *LGB* on involved a shift in attention from the notion of '(non)intersecting reference' towards the notions 'free' and 'bound' in terms of 'coindexing'. The *LGB* approach allowed for a better

⁷ See Lasnik (1976) (and references quoted therein, and Chomsky (1981:227,fn.45), where it is suggested that it might be excluded by a principle of discourse.

⁸ See in particular the observations of Bolinger (1979) and Carden (1982) on backwards pronominalization, and, for a different view, Neale (1990).

understanding of the relation of binding phenomena and movement, and for the formulation of general constraints applying to both (cf. 3.2). At the same time, however, the move away from treating pronominal noncoreference in terms of 'nonintersecting reference' and towards an analysis in terms such as 'free', i.e. non-coindexed, led to an approach of binding phenomena in which the notion 'coreference' is conceived of in 'externalist' terms. In an 'externalist' approach of *coreference* and *bound*, coindexed elements are taken to share the same external reference. The notion 'coindexing' appears to be particularly susceptible to such an interpretation, since the relation between indices has no inherent semantic import (see also Lasnik 1989). Therefore, the notion 'coindexing' may have contributed to the 'externalist' view, despite Chomsky's (1981:161) early warning that it should be viewed as no more than a technical device, perhaps eliminable from the grammar. The analysis of binding phenomena in terms of '(non)intersecting reference' is less susceptible to an 'externalist' view of binding, since it requires a definition of the notion of intersection that depends on linguistic representations.⁹

The use of the notions of 'coreference' and 'reference' in Chomsky's writings has often given rise to misunderstandings among both linguists and philosophers. Chomsky has always been radically opposed to a linguistic role for the interpretation of the notion of reference in the Fregean sense, as only referring to 'things in the world'. He explicitly defends a radically 'internalist' conception of the notion of reference, where reference is determined by the perspective on things by a linguistic agent (see Chomsky 1976b, 1979, 1995b, 1996). This position is not shared by everyone in the field (see e.g. Bilgrami's comments in Chomsky 1996).

It should be stressed that the emphasis on a theory of binding couched in terms of coindexing made it possible to see the broader syntactic relations of binding phenomena *stricto sensu* with other dependencies, such as those generated by movement. At the same time however, this theory made it difficult to express the earlier 'internalist' semantic generalizations in terms of '(non-)intersecting reference'. In Chomsky's (1980) *On Binding* both the semantic and the syntactic aspects of disjoint reference were combined by a complex system of indexing, which allowed him to express the effects of *nonintersecting* reference in terms of *disjoint* reference. The later

⁹ Chomsky (1995a:94) states that coindexation is a symmetric relation, as opposed to an asymmetric relation, such as Higginbotham's (1983, 1985) Linking. These terms do not receive further explanation, but they can be understood to distinguish a view on coreference in terms of identity of reference (coindexation) from a view in which coreference is analyzed in terms of (non-)intersecting reference.

simplification of the system of indexing made the discussion around 'nonintersecting' reference less prominent, as pointed out by Lasnik (1989).

Summarizing, we have seen that there is an 'internalist' and an 'externalist' view on binding phenomena. Although sometimes rather implicitly, both views on binding phenomena gave rise to different research projects within the framework of generative grammar.

In our view, Higginbotham's (1983) Linking theory constitutes an example of an 'internalist' approach to coreference. Under the influence of Evans' (1980) claim that pronouns cannot be referentially dependent on each other, Higginbotham (1980ab, 1983, 1985) developed Linking theory as an alternative to Binding theory (see also Montalbetti 1984).¹⁰ Linking theory has no indices and uses an arrow notation to indicate linked elements. Linking of an element A to an element B requires that the reference of A include the reference of B. Contrary to the Binding theory indexing device, the arrow notation allows for an analysis of cases such as (12), where the pronoun *they* is linked to two antecedents.

- (12) Sue told Mary that they should go.
- 
- The diagram consists of two arrows. The first arrow starts at the word 'they' and points to the word 'Sue'. The second arrow starts at the word 'they' and points to the word 'Mary'. Both arrows are drawn below the text and are connected at their base by a horizontal line.

The facts accounted for by Condition A in Binding theory receive a fairly similar account in Linking theory to the extent that notions such as governing category and c-command are factored in. The uniqueness requirement between anaphors and their antecedents is captured by reducing the inclusion requirement to exactly one. This accounts for the ungrammaticality of (13a). However, as Lebeaux (1985) has shown, it also rules out (13b).

- (13) a * John asked Mary about themselves.
 b John asked Mary about each other.

As pointed out by Lasnik & Uriagereka (1988: 133-137), Linking theory does not account well for Condition C phenomena, since the notion 'free' is unavailable in this theory. Linking Theory is however more successful in accounting for certain cases of

¹⁰ This theory is reminiscent of the ideas in Zribi-Hertz (1979) relating anaphoricity to notions of 'intersecting reference'.

weak crossover, as well as for the four way ambiguity of *The men told each other that they should leave*. Such cases are hard to deal with in an index-based Binding theory.¹¹

In line with Higginbotham's approach, **Hoji** (this volume) argues that Principle B of the Binding theory is a condition on linking or formal dependency, rather than a condition on coindexation. His argumentation is based on a discussion of bound variable anaphora and sloppy identity in Japanese.

Tancredi (this volume) offers another 'internalist' perspective on Binding. He shows that the traditional distinction between pronouns as either bound variables or referential expressions is not sufficient to account for the constraints on the interpretation of pronouns, in view of the behavior of what he calls 'self-oriented' interpretations of pronouns. Such 'self-oriented' interpretations of pronouns cannot be captured in terms of traditional Binding conditions. Within what we would call an 'internalist' view of (co)reference, Tancredi focuses on how to generate and restrict self-orientation of pronouns in terms of the notion of 'perspective' of the person grounding the reference of the pronoun.

In contrast to these 'internalist' approaches, **Fiengo & May** (1994, this volume) can be taken to represent an example of an 'externalist' view on Binding. Sharply departing from Higginbotham (1983) and Evans (1980, 1982), they explicitly take coindexed expressions to corefer as a consequence of grammatical rule. In this context, they view syntactic identity as shape identity. From this, it follows that no external indication of the referential relation of coindexed expressions is necessary or appropriate.

3.2 Binding and locality: global vs nonunifying approaches

The modular nature of the *LGB* framework raised the question as to why the same general conditions (TSC, SSC) should apply to both movement and interpretive rules. This puzzle led several scholars to propose changes affecting the entire architecture of the grammar (see among others Van Riemsdijk & Williams 1981, and Chomsky 1995a).

The discovery of the nature of different locality principles in their relation to the various subcomponents of the grammar has been a central theme of investigation since Ross (1967a). The radical idea that there should be a general unifying concept of

¹¹ See Heim, Lasnik & May (1991) for a movement-based approach to the reciprocity case.

locality has been pursued in various ways since Koster (1978), (see among others, Bouchard 1984, Culicover & Wilkins 1987, and Koster 1987).

The view according to which all constraints apply to all types of dependencies, without the necessity of movement operations, is represented in this volume by Koster. Koster (this volume) claims, with some justification, that his approach is reminiscent of that developed in the GB framework, where both NP traces and lexical anaphors are subject to the same principle of Binding theory. He correctly points out that this unified view is absent from the more recent minimalist framework.

Aoun (1985) develops a theory which resembles Koster's (1978, 1987) to the extent that it attempts to unify the conditions on movement and binding. Aoun's approach is however crucially different from Koster's. For Koster, locality conditions apply in the same way to binding and movement, while Aoun defends the view that all dependent elements (NP-traces, Wh-traces, reflexives, pronouns etc) are anaphors, and that differences in locality conditions derive from the A or A' properties of their antecedents.

Within nonunifying approaches, the analysis of referential dependencies and the conditions applying to them were all considered to be part of an interpretive component which did not involve movement. In *LGB*, this last aspect of the theory became the main substance of Binding theory. By contrast, the conditions on A'-movement are viewed as the core of a more syntactic component (with principles mainly dealing with traces), which gave rise to the development of Bounding theory, ECP, and antecedent-government.

This division of labor introduced a tension in the theory which would have far-reaching ramifications for the position of binding within the overall architecture of the grammar. In nonunifying approaches, the status of Binding theory as a separate module allowed in principle for its application at different levels of representation (DS, SS, LF) (see among others, Chomsky 1981, 1982; Van Riemsdijk & Williams 1981; Belletti & Rizzi 1988, Lasnik 1989).

In the context of the Minimalist Program (Chomsky 1995), however, grammar internal levels of representation no longer exist: the only relevant levels are those that constitute the articulatory-perceptual (PF) and conceptual-intentional (LF) systems. In this volume, the articles by Lasnik and Freidin explore the consequences of this reductionist approach for various empirical problems involving Binding phenomena which used to be tied to specific levels of representation.

3.3 Binding and argument structure

The fact that Chomsky (1986a) formulated locality conditions on anaphors and pronouns in terms of the notion Complete Functional Complex (CFC) related the important notion of binding domain to the domain of thematic argument structure. Various linguists were thus led to explore the possibility of viewing binding as a syntactic operation whose local nature derives from the fact that it only applies between the arguments selected by a predicate. This view was further developed by Williams (1988, 1993) and Reinhart & Reuland (1993).

Following Williams (1993), **Higginbotham** (this volume) argues that Binding theory can be extended to implicit anaphora in cases such as *a self-starting motor*. This requires that Binding applies between argument positions in a thematic grid.

In **Gruber's** contribution to this volume, thematic relations are configurationally determined. In this view, binding is the result of the colinking of argument positions which is established via movement out of two conjoined thematic structures.

Minkoff (this volume) argues that control of PRO subjects should be divided into local and logophoric control. While local control is argued to be restricted by Binding principle A, logophoric control is constrained by a thematic principle.

A recent influential theory viewing Condition A effects as the result of an operation on predicate argument structure has been proposed by Reinhart & Reuland (1991, 1993). In this theory, reflexivization is viewed as a mechanism identifying two arguments of a predicate through coindexation. Reflexives that do not occur in an argument position are considered logophors, a term first introduced by Hagège (1974) and subsequently used by Clements (1975). Logophors are anaphoric elements whose interpretation is established through discourse functions.

This theory captures the distinction between monomorphemic and bimorphemic anaphors by stating that only bimorphemic anaphors can syntactically reflexivize a predicate. Monomorphemic anaphors, in the sense of Faltz (1977) and Pica (1984b), do not take part in the syntactic process of reflexivization. Such anaphors do not obey Binding conditions and are part of lexically (or inherently) reflexive predicates. This theory yields a residue: nothing excludes a sentence such as the ungrammatical **John_i washes him_i* with a reflexive interpretation. This sentence is excluded by a Chain condition stating that the tail of a chain must necessarily be referentially deficient.

Reinhart & Reuland's (1991, 1993) theory can be viewed as an attempt to break away from the symmetry between Conditions A and B in two ways: they try to show

that the dichotomy between pronouns and anaphors cannot be maintained, and argue that Conditions A and B do not apply to the same types of predicates.

This theory does not allow for an overall analysis of Condition A effects in terms of movement of (part of) the anaphor (Pica 1987, Chomsky 1995a). It also requires a syntactic framework with two levels of representation, syntactic and semantic. Importantly, the mechanism of reflexivisation is construction specific.

Safir (this volume) agrees with Reinhart & Reuland (1991) that Binding theory requires both syntactic and semantic principles, but he develops a different implementation of this idea. Reinhart & Reuland (1991) argue that Principle A is uniquely syntactic, while Principle B is semantic in nature and applies to predicate-argument structures. On the basis of a wealth of data from Scandinavian languages, Safir claims that Binding theory is symmetric to the extent that syntactic and semantic constraints apply to both Principle A and Principle B.

3.4 Binding and decomposition

To our knowledge, Pica (1987, 1991) was the first to develop the idea that the differences between various types of Binding found across languages, i.e. long distance and local Binding, derive from the internal structure of reflexives and from the element within the reflexive that moves.¹²

Postma (this volume) further explores the idea of the morphological decomposition of anaphors. He develops the idea that syntactic possession crosslinguistically encoded in anaphors (*myself* = *my self*) should be considered a syntactic way to circumvent Principle B. Postma further argues that the semantic effect of the possessive construction is neutralized through two types of 'approximation' strategies. The first strategy involves universal quantification over parts of the antecedent, and is syntactically represented in morphologically complex anaphors. The second strategy of 'approximation' involves morphologically simplex anaphors and proceeds via upward entailment: from a predication over a part of the antecedent to a predication over the entire antecedent.

¹² See Pica (1984a, 1985); Burzio (1991ab); Safir (1996); Yang (1983), and Roberts (1997) for an overview.

3.5 Binding and discourse

A number of articles in the volume address the complex relation between binding and discourse. This issue is related to the more general distinction between sentence grammar on the one hand and discourse grammar and pragmatics on the other (Reinhart 1983).

Reuland & Sigurjónsdóttir (this volume) argue that the interpretation of the Icelandic long-distance anaphor *sig* in subjunctives is constrained by discourse factors, i.e. it receives a logophoric interpretation. The interpretation of *sig* in infinitives, by contrast, involves a structural relation with the antecedent. The authors claim that there is no intrinsic necessity for anaphors to be syntactically linked to their antecedent, but that economy requires that where they can be linked syntactically, they must be.

Berman & Hestvik (this volume) develop an analysis of plural pronouns and so-called split antecedents within a framework handling anaphoric relations at a level beyond the sentential domain. This analysis is situated within the semantic perspective of Discourse Representation Theory (DRT). They argue against the notion of 'disjoint reference', and extend their account to Principle B effects, offering a formal account of anaphora resolution at a supersentential level of representation.

Demirdache (this volume) addresses the uncertain status of Principle C as a principle of grammar or as a principle of discourse. She shows that coreference anaphora is not governed by a pragmatic rule of discourse. In St'át'imcets, coreference anaphora violate Condition C, while bound variable anaphora (BVA) respect it. The restricted domain of Condition C in St'át'imcets resembles that of focused DPs in English. Demirdache develops an account based on the difference in quantificational force of DPs in St'át'imcets and English. Demirdache assumes that DPs in St'át'imcets and focused DPs in English escape Condition C because they do not undergo quantifier raising at LF. The syntax of a given DP at LF, thus, universally, determines the anaphoric relations it can enter into.

3.6 Minimalism and Binding

The exact status of Binding theory within the Minimalist program remains somewhat unclear. While some data suggest that the syntax of Binding theory involves a movement operation of (part of) the anaphor, Binding theory as such is nevertheless defined as an interface phenomenon.

The computational aspect of Binding in terms of the interaction between morphological composition and movement can be rather clearly circumscribed. The consequences of the claim that Binding applies at the LF interface are perhaps more difficult to evaluate. Chomsky (1995a:211) rephrases Binding conditions as interpretive conditions at the interface, uniting disjoint and distinct reference. In this version, Condition A is stated in terms of coreference, while conditions B and C are phrased in terms of disjointness of reference. Chomsky notes that if the effects of Condition A are storable in terms of movement, all indexing could be dispensed with.

The result of these changes is twofold. First, the indexing device for indicating coreference is again called into question. Secondly, the rigid symmetry between Conditions A and B of Binding theory is abandoned, since they are no longer phrased in exactly the same terms: while 'bound' is the exact opposite of 'free' in *LGB* terms, it is clear that 'coreferential' is not the exact opposite of 'disjoint', in the light of the discussion in section 3.1 above.

The relation between a purely linguistic computational component and an interpretive interface component which is not entirely linguistic, but related to other cognitive abilities, thus opens new ways for understanding the relation between computation and interpretation. From this perspective, interpretability is a licensing condition on the objects formed by the computational component, although it is not a part of the linguistic system itself. But exactly how interpretability works for Binding conditions is very much an open question. Since the notion of reference cannot be interpreted in an 'externalist' way for Chomsky, the Minimalist program calls for the development of an 'internalist' view on (co-)reference as an interpretability condition at the interface.

The disappearance of levels of representation in the Minimalist program presents new challenges for Binding theory, since various proposals limiting the application of Binding Conditions to certain levels of representation cannot be expressed any longer, as discussed by **Freidin** (this volume) and **Lasnik** (this volume).

The interaction of the computational component with the interfaces PF and LF offers new ways to explore the relations between the interface levels with respect to Binding phenomena.

3.7 Binding and Switch-reference

Switch-reference (SR) is the phenomenon in which the subject of an embedded clause formally indicates whether this subject should be interpreted as coreferential or noncoreferential with the subject of the matrix clause.

Following Finer (1985), **Broadwell** (this volume) analyzes Switch-reference in languages such as Choctaw, Chickasaw, and Amele as an instance of local binding from an A'-position, thereby extending the domain of application of the Binding theory. Variation in SR systems is argued to be dependent on the level of representation (DS, SS, or LF) at which the Binding theory applies.

A better understanding of SR requires a deeper insight into the typology of pronominal systems. If pronominal systems are not homogeneous across languages, it is to be expected that this will have far reaching consequences for the correct formulation of Binding principles related to Condition B. This topic is explicitly addressed in the contribution by **Frajzyngier** (this volume). On the basis of English, literary Polish, Mupun, and Lele, Frajzyngier proposes a division of pronouns into three groups as a function of their coreference possibilities: logophoric pronouns (bound within a sentence but not within a clause); switch reference pronouns (bound by an antecedent in discourse but not by the immediately preceding antecedent); and pronouns that may be bound within the same sentence or by an immediately preceding antecedent in discourse. Similar considerations can be extended to agreement systems.

4 Acknowledgements

This volume grew out of the three-day workshop on '*Atomism*' and *Binding* held on 15-17 February 1996 at the Holland Institute for Generative Linguistics (HIL), and hosted by Leiden University. We would like to thank The Netherlands Organization for Scientific Research (NWO), the Faculty of Letters at Leiden University, and the Royal Dutch Academy of Sciences (KNAW) for their generous financial aid allowing us to organize the workshop. This event was initiated by the classes which Pierre Pica taught at HIL from April to June 1995, thanks to a visitor's stipend from NWO.

We would like to thank all participants in the workshop for their enthusiastic cooperation. Thanks are due as well to the various colleagues who were gracious enough to chair the sessions, and to the audience for insightful discussions.

A special word of thanks goes to José Birker for her invaluable help in the organisation and administration of the workshop and the elaboration of this volume.

References

- Aoun, Joseph. 1985. *Generalized binding. the syntax and logical form of Wh - interrogatives*. Dordrecht: Foris.
- Bach, Emmon. 1970. Problemalization. *Linguistic Inquiry* 1. 121-122.
- Belletti, Adriana & Luigi Rizzi. 1988. Psych- verbs and θ -theory. *Natural language and linguistic theory*. 6:291-352.
- Bolinger, Dwight. 1979. Pronouns in discourse. In Talmy Givón (ed.) *Discourse and syntax*. Syntax and Semantics 12. New York: Academic Press.
- Bouchard, Denis. 1984. *On the content of empty categories*. Dordrecht: Foris.
- Burzio, Luigi. 1989. On the non-existence of disjoint reference principles. *Rivista di Grammatica Generativa* 14. 3-27.
- Burzio, Luigi. 1991a. The role of antecedent in anaphoric relations. In Robert Freidin (ed.). *Current issues in comparative grammar*. Dordrecht: Kluwer.
- Burzio, Luigi. 1991b. The morphological basis of anaphora. *Journal of Linguistics* 27. 81-105.
- Carden, Guy. 1982. Backward anaphora in discourse context. *Journal of linguistics* 18. 361-387.
- Castañeda, Héctor-Neri. 1966. 'He': a study in the logic of self-consciousness. *Ratio* 7.130-157.
- Chomsky, Noam. 1951. *Morphophonemics of Modern Hebrew*. MA Diss. University of Pennsylvania.
- Chomsky, Noam. 1955. *The logical structure of linguistic theory*. Mimeographed, MIT. Cambridge Mass. (revised and published as Chomsky (1975).
- Chomsky, Noam. 1964. *Current Issues in linguistic theory*. the Hague: Mouton.
- Chomsky, Noam. 1973. Conditions on transformations. In Stephen Anderson & Paul Kiparsky (eds) *A Festschrift for Morris Halle*. New York: Holt, Rinehart & Winston. 71-132.
- Chomsky, Noam. 1972. *Studies on semantics in generative grammar*. The Hague: Mouton
- Chomsky, Noam. 1975. *The logical structure of linguistic theory*. New York: Plenum Press.
- Chomsky, Noam. 1976a. Conditions on rules of grammar. *Linguistic Analysis* 2. 303-351.
- Chomsky, Noam. 1976b. *Reflections on language*. New York: Pantheon
- Chomsky, Noam. 1979. *Language and responsibility*. New York: Pantheon.
- Chomsky, Noam. 1980. On Binding. *Linguistic Inquiry* 11. 1-46.
- Chomsky, Noam. 1981. *Lectures on government and binding*. Dordrecht: Foris.
- Chomsky, Noam. 1982. *Some concepts and consequences of the theory of government and binding*. Cambridge, Mass: The MIT Press.
- Chomsky, Noam. 1986a. *Knowledge of language : Its nature, origin, and use*. New York: Praeger.
- Chomsky, Noam. 1986b. *Barriers*. Cambridge, Mass: The MIT Press.
- Chomsky, Noam. 1995a. *The minimalist program*. Cambridge, Mass: The MIT Press.
- Chomsky, Noam. 1995b. Language and nature. *Mind* 104. 413-59.
- Chomsky, Noam. 1996. *Language and thought*. Wakefield RI & London: Moyer Bell.
- Clements, George N. 1975. The logophoric pronoun in Ewe: Its role in discourse. *Journal of West African Language*s 10. 141-177.

- Cole, Peter & Li-May Sung. 1994. Head movement and long distance reflexives. *Linguistic Inquiry* 25. 355-406.
- Culicover, Peter & Wendy Wilkins. 1986. Control, PRO and the projection principle. *Language* 62. 120-153.
- Dougherty, Ray. 1969. An interpretive theory of pronominal reference. *Foundations of Language* 4. 448-519.
- Evans, Gareth. 1980. Pronouns. *Linguistic Inquiry* 11. 337-362.
- Evans, Gareth. 1982. *The varieties of reference*. Oxford: Clarendon Press.
- Faltz, Leonard. 1977. *Reflexivization: a study in universal syntax*. New York: Garland University Press.
- Fiengo, Robert & Robert May. 1994. *Indices and identity*. Cambridge, Mass: The MIT Press.
- Finer, Daniel. 1985. The syntax of switch-reference. *Linguistic Inquiry* 16. 35-56.
- Fodor, Jerry. 1975. *The language of thought*. Cambridge: Harvard University Press.
- Fodor, Jerry. 1983. *The modularity of the mind*. Cambridge Mass: The MIT Press.
- Hagège, Claude. 1974. Les pronoms logophoriques. *Bulletin de la Société de Linguistique de Paris* 69. 287-310.
- Heim, Irene, Howard Lasnik & Robert May. 1991. Reciprocity and plurality. *Linguistic Inquiry* 22. 63-101.
- Helke, M. 1970. *The grammar of English reflexives*. Ph.D. dissertation, MIT.
- Higginbotham, James. 1980a. Pronouns and bound variables. *Linguistic Inquiry* 11.
- Higginbotham, James. 1980b. Anaphora and GB: some preliminary remarks. In John Jensen (ed.) *Proceedings of the tenth annual meeting of NELS*. Amherst: GLSA.
- Higginbotham, James. 1983. Logical form, binding, and nominals. *Linguistic Inquiry* 14. 395-420.
- Higginbotham, James. 1985. On semantics. *Linguistic Inquiry* 16. 547-593.
- Jackendoff, Ray. 1972. *Semantic interpretation in generative grammar*. Cambridge Mass: The MIT Press.
- Kayne, Richard. 1992. *Anaphors as pronouns*. Ms CUNY.
- Keenan, Edward. 1971. Names, quantifiers and a solution to the sloppy identity problem. *Papers in Linguistics* 4. 211-232.
- Koster, Jan. 1978. *Locality principles in syntax*. Dordrecht: Foris.
- Koster, Jan. 1987. *Domains and dynasties: the radical autonomy of syntax*. Dordrecht: Foris.
- Koster, Jan & Eric Reuland. 1991. *Long-distance anaphora*. Cambridge: Cambridge University Press.
- Kripke, Saul. 1982. *Wittgenstein on rules and private language*. Cambridge Mass: Harvard University Press.
- Langacker, Ronald. 1969. On pronominalization and the chain of command. In David Reibel & Sanford Schane (eds) *Modern studies in English*. Englewood Cliffs, NJ: Prentice Hall.
- Lasnik, Howard. 1976. Remarks on coreference. *Linguistic Analysis* 2. 1-22. (reprinted in Lasnik 1989)
- Lasnik, Howard. 1989. *Essays on anaphora*. Dordrecht: Kluwer.
- Lasnik, Howard & Juan Uriagereka. 1988. *A course in GB syntax*. Cambridge Mass: The MIT Press.

- Lebeaux, David. 1985. Locality in anaphoric binding. *The linguistic review* 4. 343-363.
- Lees, Robert & Edward Klima. 1963. Rules for English pronominalization. *Language* 39. 17-28. (reprinted in Reibel & Schane eds.)
- Montalbetti, Mario. 1984. After Binding: on the interpretation of pronouns. Ph. D. dissertation, MIT.
- Neale, Stephen. 1990. *Descriptions*. Cambridge Mass: The MIT Press.
- Partee, Barbara. 1978. Bound variables and other anaphors. In D. Waltz (ed.) *Proceedings of TINLAP 2*. Urbana: University of Illinois.
- Pica, Pierre. 1984a. *Liage et contiguïté*. In Jean-Claude Milner (ed.) *Recherches sur l'anaphore*. Paris VII. 119-164
- Pica, Pierre. 1984b. On the distinction between argumental and nonargumental anaphors. In Wim de Geest & Yvan Putseys (eds). *Sentential complementation*. Dordrecht: Foris. 185-194.
- Pica, Pierre. 1985. Subject, tense and truth: towards a modular approach to binding. In Jacqueline Guéron, Hans-Georg Obenauer, & Jean-Yves Pollock (eds). *Grammatical representation*. Dordrecht: Foris. 259-292.
- Pica, Pierre. 1987. On the nature of the reflexivization cycle. In Joyce McDonough & Bernadette Plunkett (eds) *Proceedings of the Nels 17*. Amherst: GLSA.
- Pica, Pierre. 1991. On the interaction between antecedent-government and binding: the case of long distance reflexivization. In Jan Koster & Eric Reuland (eds). *Long-distance anaphora*. Cambridge: Cambridge University Press. 119-136.
- Postal, Paul. 1966. A note on understood transitively. *IJAL* 32. 90-93
- Postal, Paul. 1969. Review of A. McIntosh & M.A.K. Halliday, *Papers in general, descriptive and applied linguistics*. *Foundations of Language* 5. 409-439.
- Quine, Willard van Orman. 1960. *Word and object*. Cambridge Mass: The MIT Press.
- Quine, Willard van Orman. 1972. Methodological reflections about current linguistic theory. In Gene Harman & Donald Davidson (eds). *Semantics of natural language*, New York: Humanities Press.
- Reinhart, Tanya. 1976. *The syntactic domain of anaphora*. Ph. D. dissertation. MIT. (revised and published as 1983a).
- Reinhart, Tanya. 1983a. *Anaphora and semantic interpretation*. New York: Croom Helm.
- Reinhart, Tanya. 1983b. Coreference and bound anaphora: a restatement of the anaphora questions. *Linguistics and Philosophy* 6. 47-88.
- Reinhart, Tanya & Eric Reuland. 1991. Anaphors and logophors: an argument structure perspective. In Jan Koster & Eric Reuland (eds) *Long-Distance Anaphora*. Cambridge: Cambridge University Press. 283-321.
- Reinhart, Tanya & Eric Reuland. 1993. Reflexivity. *Linguistic Inquiry* 24. 657-720.
- Roberts, Ian. 1997. *Comparative syntax*. London: Arnold.
- Rosenberg, Jay & Charles Travis. 1971. *Readings in the philosophy of language*. Englewood Cliffs, NJ: Prentice-Hall.
- Ross, John Robert. 1967a. *Constraints on variables in syntax*. Ph. D. dissertation. MIT. (published as Ross 1975)

- Ross, John Robert. 1967b. On the cyclic nature of English pronominalization. *To Honor Roman Jakobson*. Mouton, The Hague. 1169-1682.
- Ross, John Robert. 1975. *Infinite syntax*. New York: Ablex.
- Russell, Bertrand. 1905. On denoting. *Mind*. 14, 479-493.
- Safir, Ken. 1992. Implied non-coreference and the pattern of anaphora. *Linguistics and Philosophy*. 15. 1-52.
- Safir, Ken. 1996. Semantic atoms of anaphors. *Natural Language and Linguistic theory* 14. 545-589.
- Sag, Ivan. 1976. *Deletion and logical form*. Ph. D. dissertation, MIT.
- Searle, John. 1992. *The rediscovery of the mind*. Cambridge, Mass: The MIT Press.
- Van Riemsdijk, Henk & Edwin Williams. 1981. NP structure. *The linguistic review* 1. 171-217.
- Vergnaud, Jean-Roger & Maria-Luisa Zubizarreta. 1992. The definite determiner and the inalienable construction in French and English. *Linguistic Inquiry* 23. 595-652.
- Williams, Edwin. 1977. Discourse and logical form. *Linguistic Inquiry* 8. 101-139.
- Williams, Edwin. 1988. The anaphoric nature of theta roles. *Linguistic Inquiry* 19. 425-456.
- Williams, Edwin. 1993. *Thematic structure in syntax*. Cambridge, Mass: The MIT Press.
- Yang, Dong-Whee. 1983. The extended Binding theory of anaphors. *Language Research* 19. 169-192.
- Zribi-Hertz, Anne. 1979. Grammaire et disjonction référentielle. *Semantikos* 3. 35-60.

Split Antecedents, Noncoreference, and DRT

Stephen Berman & Arild Hestvik

This article is concerned with the theory of anaphoric relations involving nonreflexive pronouns.* Our main contention is that this amounts solely to a theory of the conditions under which pronouns and their antecedents can or cannot be identified. With referential antecedents, these are conditions enforcing coreference or noncoreference (with non-referential—e.g. quantified—antecedents, the relevant notion is identity under an assignment of values to variables; cf. section 4.1). This conclusion runs counter to the widely held position within the syntactic literature that the notions of disjoint reference and (partially) overlapping reference play essential roles in the theory.¹ This position—a version of which appears at least as early as Postal (1966)—has been most forcefully defended by Howard Lasnik in a series of works (Lasnik 1976, 1981, 1986; Lasnik & Uriagereka 1988; Chomsky & Lasnik 1993).

In section 1 we review Lasnik's arguments and evidence. In section 2 we discuss empirical problems for this approach involving plural pronouns and so-called split antecedents, brought to light by Seely (1993). We then show that Seely's solution is inadequate, in light of anaphoric relations that obtain beyond the sentential domain. In section 3 we develop an alternative analysis within a framework capable of handling

* This paper is the outgrowth of research initially conducted as part of the Sonderforschungsbereich 340 at the University of Stuttgart and reported in Berman & Hestvik (1994). We are grateful to our colleagues at the University of Stuttgart for helpful discussions, and in particular to Hans Kamp for critical comments on a prefinal version of the present paper. We also would like to thank T. Daniel Seely for providing us with prepublication versions of his work on split antecedents, which was part of the instigation for our research. Earlier versions of some of this material were presented at the 1996 workshop 'Atomism and Binding' at Leiden University; the Spring 1994 meeting of the GGS at the University of Tübingen; the 1994 meeting of the LSA in Boston; colloquia at the Universities of Bergen and Oslo; and the 1993 workshop 'Between Syntax, Semantics and Logic' at the University of Stuttgart. The names of the authors are listed in alphabetical order, and the order has no nonalphabetical significance.

¹ An exception is Fiengo & May (1994); we comment briefly on their theory in section 5.

phenomena at this more inclusive level. We extend our analysis in section 4 to the effect of Principle B of the Binding Theory, developing a formal account motivated by the various possibilities of anaphora resolution at the supersentential level of representation. We conclude in section 5 with a discussion of the empirical status of binding theory effects involving split antecedents, briefly contrasting our approach with that of Fiengo & May (1994), and point to some consequences of our analysis.

The syntactic perspective of this article is that of the Principles and Parameters framework (GB; see e.g. Chomsky & Lasnik 1993) and the semantic perspective that of Discourse Representation Theory (DRT; see Kamp & Reyle 1993). Our analysis can be viewed as one way of working out the hypothesis stated by Chomsky (1993:43 [1995:211]) that “binding conditions hold only at the LF interface,” taking DRT to be the theory of this interface.

1 Lasnik’s theory of referential relations

The starting point for Lasnik’s theory of anaphoric relations is the behavior of referential NPs and the kinds of relations they enter into. He addresses two questions: (i) what referential relations can, must, and cannot obtain between two or more NPs in a single sentence; and (ii) what theoretical vocabulary is necessary to account for the answer to question (i). Lasnik observes that there are four types of referential relations two NPs (and correspondingly, their denotata) may have with respect to each other: coreference, noncoreference, disjoint reference, and (partially) overlapping reference. Let A and B be NP denotata; for concreteness, we take these to be sets of individuals.² Then these relations are defined as follows:

- (1) a Coref(A, B): $A = B$
 b Noncoref(A, B): $A \neq B$
 c Disjoint(A, B): $A \cap B = \emptyset$
 d Partial-Overlap(A, B): $(A \cap B \neq \emptyset) \wedge (A \neq B)$

² In the case of singular NPs, their denotata will thus be singletons; cf. also footnote 14. Since we are not concerned here with presenting a compositional translation from syntactic representation to semantic interpretation, treating referential NPs as denoting sets of individuals is most convenient for our purposes.

The following examples illustrate each of these relations in turn, obtaining in each case between the italicized NPs:

- (2) a *Mary* believes John is proud of *her*.
 b *The students* believe John is proud of *them*.
- (3) a *Mary* is proud of *her*.
 b *The students* are proud of *them*.
- (4) a *Mary* is proud of *them*.
 b *The students* are proud of *her*.
- (5) a *Mary* believes John is proud of *them*.
 b *The students* believe John is proud of *them*.

Concerning question (i), according to Lasnik noncoreference must—and hence coreference cannot—obtain in (3), while disjoint reference must—and hence partially overlapping reference cannot—obtain in (4). In (2) and (5) the pronouns have what Lasnik calls *free reference*, that is, any of the referential relations is possible (modulo number agreement) but not obligatory.³ This difference between (3)/(4) and (2)/(5) shows that referential relations hold obligatorily only in a certain local domain, known as the pronoun's *binding domain*: in these examples, the minimal sentential clause containing both pronoun and antecedent (see e.g. Chomsky 1981, 1986 for detailed discussion). In addition, the obligatoriness holds only if the antecedent c-commands the pronoun; thus in the following examples, noncoreference and disjoint reference are not required, although the antecedents occur in the pronouns' binding domain ((6b) is from Lasnik (1976:(36a)):

- (6) a The man who smiled at *Mary* likes *her*.
 b The man who forced *Tom* to hit *Harry* hates *them*.

As for question (ii), Lasnik claimed (1976 [1989:102]) that the syntactic configurations of obligatory noncoreference and obligatory disjoint reference coincide. Given this, and since it is a consequence of the definitions in (1) that disjoint reference asymmetrically entails noncoreference, it follows that the latter relation is theoretically

³ If in (3b) *the students* and *them* denote nonidentical sets of individuals, then this sentence exemplifies disjoint reference. Since plurality only entails a cardinality of two or more, the same sentence can be used to illustrate coreference or partially overlapping reference between a plural pronoun and a plural antecedent, as seen by (2b) = (5b).

derivative. This leads to the following regulative principle for nonreflexive pronouns, to account for data such as (2)-(6) (Chomsky & Lasnik 1993:551(211b) [1995:100]):

(7) *Disjoint Reference Condition*

A nonreflexive pronoun must be disjoint in reference from every c-commanding NP in its binding domain.

The regulative principle for nonreflexive pronouns constitutes Principle B in the Binding Theory of Chomsky (1981) and later work; henceforth we refer to it (in whatever formulation is relevant to the point at hand) as *BT(B)* and to the semantic constraints it is designed to enforce as *BT(B) effects*.⁴

Just as disjoint reference entails noncoreference, so does coreference entail overlapping reference, if the requirement of partiality (the nonidentity conjunct in (1d)) is removed. However, while coreference is required with reflexives, Lasnik contended (1981:fn.8) that there are no cases of obligatory partially overlapping reference.⁵ Therefore, he concluded (1981 [1989:131]) that the relations of coreference, disjoint reference, and partially overlapping reference are independent primitives of the theory of referential relations.

⁴ BT(A) regulates the anaphoric relations of reflexive pronouns, which we refrain from treating here. These are complicated by the phenomenon of nonlocally bound reflexives, as in so-called picture noun phrases and logophoric contexts; see e.g. Hestvik (1992) and Reinhart & Reuland (1993). We also omit discussion of anaphoric relations between nonpronominal NPs (regulated by BT(C)). The anaphoric possibilities here are complicated by bridging phenomena, though whether these are grammatically regulated is controversial; see van Dæmter (1992, 1994) for an analysis within the DRT framework.

⁵ This appears not to be the case at least with non-locally bound reflexives, however; consider the following contrast:

- (i) Mary wanted to surprise her sisters. She hung a picture of them on the wall.
- (ii) Mary wanted to surprise her sisters. She hung a picture of themselves on the wall.

In (i) Mary need not (but may) be included in the reference of *them*, but in (ii) Mary must be included in the reference of *themselves*. Note, too, that reflexives do not exhibit free reference: unlike the difference between (2) and (3), the following is a contrast in grammaticality, not interpretation:

- (iii) Mary is proud of herself.
- (iv) * Mary believes that John is proud of herself.

As we are not treating reflexive pronouns in this paper, we refrain from drawing any conclusions from these observations.

2 Counterexamples to disjoint reference

2.1 Sentence internal split antecedents

It is significant that Lasnik's theory of anaphoric relations is based only on examples in which the c-commanding potential antecedents of the pronoun are either all within the pronoun's binding domain or else all outside of it. Seely (1993) has, however, drawn attention to the fact that a third possibility exists in the case of so-called split (i.e. nonconjoined) antecedents: namely, that (at least) one of the antecedents is within the pronoun's binding domain, and (at least) one is outside of it. He observed that in such a configuration, a relation of coreference with the antecedents taken jointly, and thus of partially overlapping reference with each, is possible; this is illustrated by the following examples, patterned on Seely's (7a), (9a)-(15a), where again italicization indicates anaphora:

- (8) a *John* wants [CP *Mary* to represent *them*].
 b *John* asked *Mary*_i [CP PRO_i to represent *them*].
 c *John* said that [CP *Mary* represented *them*].
 d *John* was happy because [*Mary* had protected *them*].
 e *John*_i pleased *Mary* only by [PRO_i standing up for *them*].
 f *John* really resented [*Mary's* description of *them*].

As Seely points out, this counterexamples Lasnik's empirical claim, and hence his formulation of BT(B) as a disjoint reference condition.⁶

To account for such cases, Seely introduces the notion of *exhaustive binding*, defined in terms of a system of indexation in which an index consists of a set of integers (following Lasnik 1989):

- (9) a *X* is *exhaustively bound* iff every syntactically dependent member of the index of *X* is c-commanded by its antecedent; *X* is free otherwise.

⁶ Fiengo & May (1994:40) also cite the following example as exhibiting acceptable overlapping reference (we return to their view of split antecedents in section 5):

(i) *Watson* said *Crick* expected *them* to win the Nobel Prize.

- b A member M of the index of X is *syntactically dependent* if M is identical with a member of the index of an intrasentential NP; we refer to that NP as the antecedent of M.⁷
- c BT(B): A pronoun must be free (i.e. not exhaustively bound) in its binding domain.

Stated in referential terms, Seely's version of BT(B) requires the pronoun's reference not to be exhausted by the joint references of c-commanding antecedents within its binding domain. To illustrate, consider (8a), here annotated with set indices:

(10) John_{1} wants [CP Mary_{2} to represent them_{1,2}].

Although by (9a) the pronoun here is exhaustively bound, it is nevertheless free in its binding domain (the embedded CP), satisfying BT(B) (9c). Thus, the pronoun is free in reference; in particular, coreference with the two antecedent NPs taken together is permitted. In contrast, in (11) (= Seely's (6)), the pronoun is exhaustively bound inside its binding domain, which precludes the indicated anaphoric relation:

(11) *Bill_{1} told Mary_{2} about them_{1,2}.

Examples such as the following, not discussed by Seely, are also consistent with his analysis:

- (12) a [John_{1}'s mother]_{2} protected them_{1,2} from the robbers.
- b [The woman who loves John_{1}]_{2} represented them_{1,2} at the trial.

Although in each of these examples the antecedent NPs, which exhaust the pronoun's reference, are both within the pronoun's binding domain (the matrix CP), one of them (namely *John*), does not c-command the pronoun. Thus it is not exhaustively bound and hence referentially free.

⁷ We have corrected Seely's actual definition, which reads: "A member M of the index of X is syntactically dependent if M is identical with the index of an intrasentential NP." This cannot be right, given the definition of an index as a set of integers.

2.2 Intersentential split antecedents

The requirement of syntactic dependence in (9a) restricts overlapping reference within the binding domain to cases where the antecedents that are outside of the binding domain are still within the maximal syntactic clause containing the pronoun. This is because Seely regards cases like the following, where one or more of the antecedents are outside of the sentence containing the pronoun altogether, as ungrammatical:

(13) John_{1} said [CP Mary_{2} represented them_{2,3}].

By (9a), the pronoun in (13) is exhaustively bound by *Mary*, since the latter is the only NP on which the pronoun is syntactically dependent. Since *Mary* also c-commands the pronoun in its binding domain, BT(B) as stated in (9c) is violated and the sentence is ruled ungrammatical on the intended anaphoric relation.

However, while it is true that if (13) were uttered out of the blue, with no previous context, the only way to understand the pronoun would be as referring jointly to the references of *John* and *Mary*, additional context removes this restriction:

- (14) a *Bill* and *Mary* were asked to appear before the committee. But *Bill* fell ill and had to be excused. John said that *Mary* represented *them*.
 b *Bill* and *Mary* were charged with a crime. *Mary*, being a lawyer, decided to handle the defense. John said that *Mary* represented *them*.

In these examples, there is no intuitive difficulty establishing an anaphoric relation between *them* and *Bill* and *Mary* taken together, in contrast to the prediction of Seely's version of BT(B). That is, it is possible for the reference of a pronoun to be determined by split antecedents, at least one of which c-commands the pronoun within its binding domain and at least one of which does not occur in the sentence containing the pronoun at all.

2.3 Inclusive reference

Seely's theory could easily be repaired by removing the requirement that only sentence internal antecedents may suspend the disjoint reference condition. However, there is more telling evidence against Seely's version of BT(B). If the pronoun's reference is a proper subset of that of a single NP that c-commands it, then we have a special case of

partial overlap, sometimes called *inclusive reference*. Lasnik judged inclusive reference to be impossible within the binding domain of the pronoun, and Seely explicitly agreed with his judgment. However, just as with split antecedents, we find that cases of inclusive reference are acceptable in a suitable context. Consider the following examples (the relevant binding domain is bracketed):

- (15) a John_{1} and Mary_{2} often connive behind their colleagues' backs to advance the position of one or the other. This time, they_{1,2} managed [PRO_{1,2} to get her_{2} a position in the front office].
- b John_{1} and Mary_{2} were experiencing marital strife, so they_{1,2} called up Bill_{3} to discuss the situation. [They_{1,2,3} talked about them_{1,2} for the rest of the evening].
- c John_{1} and Mary_{2} were charged with a crime. Since Mary_{2} is a lawyer, [they_{1,2} wanted her_{2} to represent them_{1,2}].
- d John_{1} and Mary_{2} discussed their_{1,2} participation in the upcoming contest with Bill_{3}. [They_{1,2,3} expect them_{1,2} to win].

These discourses constitute additional direct counterexamples to Lasnik's disjoint reference condition, but also to Seely's analysis, since although the c-commanded pronoun is exhaustively bound in its binding domain, nevertheless, its reference can overlap with the reference of the binding NP.

2.4 Preliminary conclusions

The data we have discussed in this section go beyond those brought to bear by Seely against Lasnik's analysis. One might try to continue amending the analysis along the same lines, by further altering the domain of application of disjoint reference. But we draw a different conclusion: that BT(B) does not, contra Lasnik, directly enforce disjoint reference within its domain of application.

The data also point to a conclusion that is a commonplace of discourse-based approaches to anaphoric relations, but one often ignored in syntactically oriented approaches: that a pronoun whose reference cannot be resolved within an utterance context is at the very least pragmatically misused, and the discourse as a whole becomes infelicitous; the effect is essentially that of presupposition failure. This is well-illustrated by examples such as the following:

- (16) a The men said Mary likes them.
b The men said Mary likes him.

According to Lasnik's theory, the reference of the pronoun in these cases is free with respect to the reference of the matrix subject NP. But this is not what we find. Out of the blue, *them* in (16a) can only be understood as coreferential (and crucially not partially overlapping in reference) with *the men*, while the reference of *him* in (16b) cannot be resolved, making the sentence infelicitous in this minimal context (i.e., there is no way of knowing whether the person denoted by *him* is one of the men or not). In other words, although these sentences do not *per se* involve BT(B) violations, still the first is constrained in the way it can be interpreted and the second has no felicitous interpretation.

This observation indicates that part of the task of interpreting a (referentially used) pronoun is to resolve its reference, and if this cannot be done within the sentence, then it must be done within the wider context, if discourse felicity is to be maintained. Moreover, as data such as the examples in (14)-(15) show, this can result in overlapping reference with the pronoun within its binding domain, which demonstrates that it is misguided to prohibit this possibility, as both Lasnik's and Seely's versions of BT(B) do. For this reason, we also take such data to constitute convincing evidence against any sentence-bound approach to anaphora (at least as far as nonreflexive pronouns are concerned). The most appropriate way of analyzing this, we contend, is as a discourse-level requirement of coreference. This approach enables the underlying theory of anaphoric relations to be simplified to a binary distinction between coreference and noncoreference, or more generally, between identity and nonidentity, in a sense we will make precise in the next two sections.

3 Anaphoric relations at the discourse level

To formally implement this approach, we need a framework in which extrasentential, or discourse-level, relations can be treated in the same way that intrasentential relations can. Such a framework is available in Discourse Representation Theory (DRT; see Kamp & Reyle 1993 for a detailed exposition of the theory). In this section, we briefly review how anaphoric relations are dealt with in DRT, paying particular attention to plural pronouns and split antecedents. We then show how the counterexamples to disjoint reference are predicted to be acceptable by this theory under a noncoreference version of BT(B).

3.1 Pronominal reference in DRT

In DRT, certain kinds of semantic representations, called *Discourse Representation Structures* (DRSs), are algorithmically and incrementally constructed from syntactic representations.⁸ A DRS K consists of a pair of sets $\langle U_K, Con_K \rangle$, called its universe and its condition set. (DRSs are customarily represented by means of boxlike drawings, with the members of the universe displayed at the top and the conditions arrayed below.) U_K is made up of *discourse referents*, which play a role similar to variables in predicate logic, and Con_K consists of predicates over those discourse referents (these predicates, which are derived from the syntactic representation, may be complex and contain other DRSs as components; thus the notion of a DRS is recursive). In the initial stages of DRS construction, the elements of Con_K are syntactic structures, which are gradually decomposed by the DRS construction algorithm into structures resembling formulae of predicate logic. Like such formulae, DRSs have a well-defined modeltheoretic semantics. To be precise, a DRS K is true in a given model M iff there is a way of embedding the universe of K into that of M , i.e. of associating individuals of M with the discourse referents in U_K , such that these individuals satisfy, in M , the DRS conditions of K over the corresponding discourse referents.

The discourse referents that initially concern us are those introduced by noun phrases. In DRT, every occurrence of an NP in a sentence is represented by a unique discourse referent in the DRS being constructed from the sentence. In the case of nonpronominal NPs, the construction algorithm also introduces into the DRS specific conditions over the discourse referent, providing the descriptive content of the NP, or with names, anchoring the discourse referent to the individual so named; we will call these *content conditions*. A pronoun is not directly associated with content conditions;⁹ rather, the discourse referent that represents it must be linked to some discourse referent that is associated with content conditions. We will refer to this procedure as *pronominal resolution*. Formally, this is done by adding to the DRS an identity condition over the discourse referents introduced by the pronoun and its antecedent (in the modeltheoretic embedding, these discourse referents are associated with the same individual(s)). This treatment of pronouns is encapsulated in the DRT construction rule for pronouns, a

⁸ A single DRS may contain the semantic representation of multiple sentences, as many as comprise the text or discourse in question: in such cases, DRS construction proceeds sequentially from one sentence to the next.

⁹ However, it may be associated with grammatical information about person, gender, and number. We ignore the first two, to simplify the exposition; but number will play a central role in our analysis.

simplified version of which is the following:

(17) *CR.PRO* (first version)

If α is a pronoun in a syntactic structure S , carry out the following operations on the immediate DRS K in which α occurs:

- (a) Introduce a new discourse referent β into UK and in $ConK$ substitute β for the syntactic structure consisting of α and its categorial projections.
- (b) Add to $ConK$ the condition $\beta = \gamma$, where γ is a suitable accessible discourse referent.¹⁰

The restriction to the immediate DRS in which the pronoun occurs is intended to allow for the pronoun's occurring bound in the scope of a quantifier or an attitude expression, though we ignore the latter and only briefly touch on the former in this paper.¹¹ Clause (a) of *CR.PRO* reduces the syntactic structure by removing all the nodes of the pronoun's syntactic projection. The suitability requirement in clause (b) is meant to insure that the pronoun and its antecedent share relevant grammatical features such as person, gender and number. (Note, incidentally, that there is no requirement that the antecedent discourse referent be introduced by a linguistic entity; this allows for deictic resolution of the pronoun.)

We illustrate pronominal resolution first with a simple example. Consider the following discourse:

(18) John smiled. Mary kissed him.

The two DRSs in (19) give the processing of the text in (18), prior (in (19a)) and

¹⁰ Accessibility is a relation between discourse referents and DRS conditions; informally, a discourse referent α is accessible from a condition β in a DRS K provided that the condition set containing β is at least as embedded within K as is the DRS universe containing α (accessibility is formally defined in terms of the subordination relation mentioned in footnote 11). For most examples we are concerned with, the accessibility relation is trivial, since the relevant universe and condition set are both immediate constituents of the same DRS; only for pronouns dependent on quantificational expressions does the accessibility requirement make an essential difference (see (28) in section 4.1). We will follow Kamp & Reyle in occasionally speaking of a discourse referent as being accessible from a given DRS K , meaning it is accessible from any condition in $ConK$.

¹¹ The phrase 'immediate DRS' is an informal term of convenience: the notion can be formally spelled out in terms of the DRT notion of subordination defined by Kamp & Reyle.

subsequent (in (19b)) to pronominal resolution:¹²

(19) a	<table style="border-collapse: collapse; width: 100%;"> <tr> <td style="border-bottom: 1px solid black; padding: 2px 5px;">x y z</td> </tr> <tr> <td style="padding: 2px 5px;">John(x) [x smiled] Mary(y) [y [kissed z]]</td> </tr> </table>	x y z	John(x) [x smiled] Mary(y) [y [kissed z]]
x y z			
John(x) [x smiled] Mary(y) [y [kissed z]]			
b	<table style="border-collapse: collapse; width: 100%;"> <tr> <td style="border-bottom: 1px solid black; padding: 2px 5px;">x y z</td> </tr> <tr> <td style="padding: 2px 5px;">John(x) x smiled Mary(y) y kissed z z = x</td> </tr> </table>	x y z	John(x) x smiled Mary(y) y kissed z z = x
x y z			
John(x) x smiled Mary(y) y kissed z z = x			

The conditions *John(x)* and *Mary(y)* are the content conditions associated with the discourse referents introduced by the NPs *John* and *Mary*, respectively. The conditions [x smiled] and [y [kissed z]] represent the reduced syntactic structures of the sentences in (19); i.e. [y [kissed z]] is an abbreviation of the tree structure:

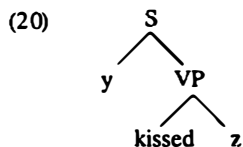

Following Kamp & Reyle (1993), we frequently omit the bracketing on reduced syntactic representations, as in (19b).

The fact that syntactic structures are themselves DRS conditions means that we can speak of discourse referents as entering into c-command relations. To be precise, let α and β be distinct NPs in a syntactic structure *S*, such that α c-commands β , and let γ and δ be the discourse referents introduced by α and β , respectively; then we say that γ c-commands δ . We will make use of this later in our analysis.

The condition $z = x$ in (19b) renders the effect of coindexation in GB theory, and can be viewed as corresponding to what is described in the GB-literature as 'assignment of coreference' between the pronoun and its antecedent (in addition, the identity condition is used for pronominal resolution to a nonreferential antecedent, as we will show later).

With plural pronouns, the situation becomes more complex. First, we must introduce discourse referents that map to entities denoted by plural NPs (i.e. sets of

¹² For simplicity, we omit the conditions anchoring the discourse referents for *John* and *Mary* to the respective individuals denoted by these NPs, and also the discourse referents and associated conditions of verbal event arguments.

individuals). The informal DRT-notation for these discourse referents is capital letters; we will also informally refer to these as plural discourse referents.¹³ Next, the plural pronoun has to be resolved. When a single plural NP is the antecedent of a plural pronoun, the DRS processing is analogous to the case of singular anaphora. For example, the final DRS for the text “*The men are happy. The women like them.*” would look like (19b) except for the obvious lexical differences and having plural discourse referents. But as the phenomenon of split antecedents shows, a plural pronoun can also be resolved to the totality of several distinct NPs in the discourse. To handle this, DRT employs a special procedure, called *Summation*. The following definition (slightly simplified from Kamp & Reyle 1993:308) introduces a single plural discourse referent and identifies it with the ‘sum’ of any number of distinct discourse referents.

(21) *Summation*

If β_1, \dots, β_n ($n \geq 2$) are discourse referents accessible from a DRS K , then the following operation may be carried out: Introduce a new plural discourse referent Γ into U_K and the condition $\Gamma = \beta_1 \oplus \dots \oplus \beta_n$ into Con_K .

In the modeltheoretic embedding of a DRS containing a Summation condition, the plural discourse referent Γ is mapped, in set-theoretic terms, to the set that comprises the union of the images under the embedding of β_1, \dots, β_n (recall from footnote 3 that we are taking singular NPs to denote singletons).¹⁴

Here is an example of Summation, as it applies in the following discourse, where the intended reference of *they* is Mary and John:

(21) *Mary invited John to dinner. They had Chinese food.*

¹³ In official DRT terminology, singular and plural discourse referents are called *atomic* and *nonatomic*, respectively. Formally, they are distinguished by being associated with conditions of the form $at(x)$ and $non-at(x)$, respectively, which are not what we are calling content conditions but rather conditions that fix logical type; cf. footnote 14.

¹⁴ In the actual DRT model theory of Kamp & Reyle (1993), plural NPs denote nonatomic elements of a complete atomic join semilattice, and Summation is modelled by the join operation on the lattice; however, there is no truthconditionally relevant difference between the lattice-theoretic and set-theoretic exposition. Because of this, we will say that the discourse referents for two NPs whose denotation spaces in the NP algebra coincide, are of the same atomicity (i.e., atomic or nonatomic).

The DRS construction contains three stages: first, the construction of the universe and condition set based on the syntactic input; second, the Summation induced by the two individual discourse referents introduced by *Mary* and *John* (this operation can already apply before the second sentence of (21) is processed); third, the pronominal resolution. The following DRSs (which again omit irrelevant details) give these stages, with (22c) being the final DRS:

(22) a	b	c																																	
<table style="width: 100%; border-collapse: collapse;"> <tr> <th style="border-bottom: 1px solid black; padding: 2px;">x</th> <th style="border-bottom: 1px solid black; padding: 2px;">y</th> <th style="border-bottom: 1px solid black; padding: 2px;">X</th> </tr> <tr> <td style="padding: 2px;">Mary(x)</td> <td style="padding: 2px;">John(y)</td> <td style="padding: 2px;">x invited y to dinner</td> </tr> <tr> <td style="padding: 2px;"></td> <td style="padding: 2px;"></td> <td style="padding: 2px;">X had Chinese food</td> </tr> </table>	x	y	X	Mary(x)	John(y)	x invited y to dinner			X had Chinese food	<table style="width: 100%; border-collapse: collapse;"> <tr> <th style="border-bottom: 1px solid black; padding: 2px;">x</th> <th style="border-bottom: 1px solid black; padding: 2px;">y</th> <th style="border-bottom: 1px solid black; padding: 2px;">X</th> <th style="border-bottom: 1px solid black; padding: 2px;">Y</th> </tr> <tr> <td style="padding: 2px;">Mary(x)</td> <td style="padding: 2px;">John(y)</td> <td style="padding: 2px;">x invited y to dinner</td> <td style="padding: 2px;">X had Chinese food</td> </tr> <tr> <td style="padding: 2px;"></td> <td style="padding: 2px;"></td> <td style="padding: 2px;">Y = x@y</td> <td style="padding: 2px;"></td> </tr> </table>	x	y	X	Y	Mary(x)	John(y)	x invited y to dinner	X had Chinese food			Y = x@y		<table style="width: 100%; border-collapse: collapse;"> <tr> <th style="border-bottom: 1px solid black; padding: 2px;">x</th> <th style="border-bottom: 1px solid black; padding: 2px;">y</th> <th style="border-bottom: 1px solid black; padding: 2px;">X</th> <th style="border-bottom: 1px solid black; padding: 2px;">Y</th> </tr> <tr> <td style="padding: 2px;">Mary(x)</td> <td style="padding: 2px;">John(y)</td> <td style="padding: 2px;">x invited y to dinner</td> <td style="padding: 2px;">X had Chinese food</td> </tr> <tr> <td style="padding: 2px;"></td> <td style="padding: 2px;"></td> <td style="padding: 2px;">Y = x@y</td> <td style="padding: 2px;">X = Y</td> </tr> </table>	x	y	X	Y	Mary(x)	John(y)	x invited y to dinner	X had Chinese food			Y = x@y	X = Y
x	y	X																																	
Mary(x)	John(y)	x invited y to dinner																																	
		X had Chinese food																																	
x	y	X	Y																																
Mary(x)	John(y)	x invited y to dinner	X had Chinese food																																
		Y = x@y																																	
x	y	X	Y																																
Mary(x)	John(y)	x invited y to dinner	X had Chinese food																																
		Y = x@y	X = Y																																

The effect of Summation is to make available in the DRS a plural discourse referent, which can then serve as the antecedent of a plural pronoun. Without Summation, and in the absence of some other accessible plural discourse referent, pronominal resolution could not be carried out: the discourse referent of a plural NP and the discourse referent of a singular NP are of distinct atomicity (cf. footnote 14), so the latter is not suitable for the former, in the sense of CR.PRO. As a result, the plural discourse referent would not be associated with any content conditions, so that if the DRS were embedded into a model, it would be sufficient for truth, given the interpretation rules of DRT, that some set of individuals satisfy the predicates over the plural discourse referent. For example, (21) would be true as long as at least two arbitrary individuals had Chinese food; clearly these are incorrect truth conditions. This deviance can be seen as a formal expression of the infelicity that arises when a pronoun fails to get resolved to a suitable antecedent within the discourse that it occurs in; cf. the discussion of (16) in section 2.4. But because of Summation, the plural discourse referent X in (22) does have a suitable antecedent and is consequently associated with content conditions by being identified with the 'sum' denoted by Y, each of whose 'summands' is associated with a content condition.¹⁵

¹⁵ The 'summands' need not be singular, in view of texts like *Mary*_{1} and *Bill*_{2} invited *John*_{3} to dinner. *They*_{1,2,3} had Chinese food. Summation could apply iteratively to the DRS for this text, giving X = x@y for the conjoined NP *Mary and Bill*, and Y = z@X as the resolving condition for the pronoun. Cf. the discussion of the DRS in (31) in section 4.2.

3.2 Split antecedents and overlapping reference

A direct consequence of the availability of Summation is an account of the possibility of partially overlapping reference with a pronoun within its binding domain. In particular, Seely's counterexamples to disjoint reference fall out straightforwardly. For example (8a), repeated here as (23a), receives the DRS in (23b) (abstracting away from the DRT treatment of propositional attitudes):

(23) a *John wants Mary to represent them.*

b

x	y	X	Y
John(x)			
Mary(y)			
[x wants [y to represent X]]			
Y = x⊕y			
X = Y			

Examples like (12), in which both split antecedents are within the pronoun's binding domain but one of them fails to c-command the pronoun, would receive a similar DRS. Moreover, since Summation is not a sentence-bound operation, examples like (14), where the pronoun is exhaustively bound according to Seely's analysis, because one of its split antecedent does not occur in the sentence at all, are also straightforwardly accounted for on our approach.

Also predicted is the existence of inclusive reference, as in the sentences in (15); consider for example (15c), repeated here as (24a), which exhibits in the same sentence both properly overlapping and inclusive reference within the two lower pronouns' respective binding domains:

(24) a *John_{1} and Mary_{2} were charged with a crime. Since Mary_{2} is a lawyer, [CP they_{1,2} wanted [CP her_{2} to represent them_{1,2}]].*

b

x	y	z	X	w	Y	Z
John(x)	Mary(y)	crime(z)				
[x and y were charged with z]						
lawyer(y)						
[X wanted [w to defend Y]]						
Z = x⊕y						
w = y						
X = Z						
Y = Z						

CR.PRO correctly permits overlapping reference between a singular pronoun and a plural NP in its binding domain, although the pronoun's reference is included in the reference of the NP.

It is worth emphasizing that in all these cases the overlapping reference is a by-product of anaphoric relations independently established by means of identity conditions, which may be mediated by Summation; this is clearly seen in (24b). In other words, in our theory, in contrast to Lasnik's, overlapping reference is a derivative notion; only coreference and its dual, noncoreference (or more generally identity and non-identity) play a significant role. It is also clear that the term 'split antecedents' is a syntactic description, since semantically an anaphoric element only has a single antecedent, though this may be (and in the case of split antecedents is) only representable at the discourse level.

One may wonder why DRT has Summation but not the converse operation, which would take a plural discourse referent and make arbitrary 'subsums' (down to single discourse referents) available, thus allowing inclusive reference to be directly established. The reason is empirical: whereas forming the sum of arbitrary NPs is always possible (up to processing constraints), it is in general not possible to resolve a singular pronoun to an unexplicit part of plural antecedent, as (16b) illustrates.¹⁶ (cf. also Partee's well-known example: **Nine of the ten marbles are in the bag; it is under the couch*)

¹⁶ There is, however, one type of exception to this generalization, namely, where the antecedent denotes a male/female pair: *That couple_{1,2} is interesting: he_{1} is a gardener and she_{2} is a physicist.* (Similar examples with plural pronouns do not exist in English due to the absence of gender marking here.) For simplicity, we disregard such cases in the present account. See van Deemter (1992) for an analysis on which the licensing of such anaphora by pronouns is semantically on a par with standard identity anaphora (e.g. coreference).

4 Incorporating noncoreference restrictions into DRT

4.1 Basic noncoreference

The resolution clause (b) of CR.PRO as formulated in (17) restricts the relation between the pronoun and its antecedent only in terms of suitability and accessibility. Obviously, the basic effect of BT(B), illustrated in (25), must be added to the DRT treatment of pronouns, since anaphora between the pronouns and the nonpronominal NPs is impossible in these cases:

- (25) a **John likes him.*
 b **The men like them.*

Unlike the examples in section 2, where apparent disjoint reference disappears in a suitable context, there is no ordinary discourse in which these sentences are acceptable if the two NPs are intended to corefer.¹⁷

In terms of our analysis, we have two alternatives for ruling out coreference in sentences like (25a-b). One is simply to adopt a suitable version of BT(B) as an independent grammatical principle, following the usual course taken in GB theory. But Kamp & Reyle (1993:238) proposed incorporating the effect of BT(B) into the DRT construction rule for pronouns, CR.PRO, as an additional constraint on the resolution clause, rather than stating it elsewhere in the grammar. This is appealing on the grounds of conceptual simplicity and theoretical economy: since BT(B) regulates the anaphoric aspect of the interpretation of pronouns, it is natural that its effect should be part of the operation that yields the semantic representation of pronouns.¹⁸

¹⁷ There are, however, certain 'out-of-the-ordinary' contexts in which coreference even in these cases is intuitively acceptable; see e.g. Evans (1980), Reinhart (1983), and Heim (1993). These involve circumstances where the use of a nonreflexive pronoun sanctions a reading not available with a reflexive pronoun. Most of these are felt to be contrived and unnatural, in contrast to the cases of apparent disjoint reference we have been discussing. It therefore seems plausible to treat them, as Heim does, as cases where BT(B) can be set aside in specific contexts, rather than as being configurations where BT(B) does not apply in principle. See also Chomsky (1981:314 (fn. 3)).

¹⁸ Obviously, building BT(B) into CR.PRO means that this construction rule can handle only nonreflexive pronouns. A separate rule will be needed for reflexive pronouns (possibly two, for locally and nonlocally bound reflexives), with a different resolution clause. (See Asher & Wada (1988) for an earlier analysis using DRT principles to account for restrictions on pronominal anaphora, but one

Kamp & Reyle's formulation of CR.PRO incorporates a simplified BT(B), confined to singular pronouns; our version applies to both singular and plural pronouns:¹⁹

(26) *CR.PRO* (second version)

If α is a nonreflexive pronoun in a syntactic structure S , carry out the following operations on the immediate DRS K in which α occurs:

- (a) Introduce a new discourse referent β , of the appropriate atomicity for α , into UK and in $ConK$ substitute β for the syntactic structure consisting of α and its categorial projections.
- (b) Add to $ConK$ the condition $\beta = \gamma$, where
 - (i) γ is a suitable accessible discourse referent;
 - (ii) γ does not c-command β within β 's binding domain.

To illustrate, here is the DRS for (25b):

(27)

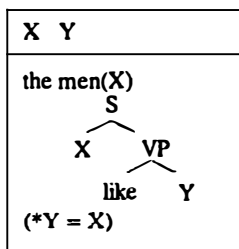

The discourse referent Y (instantiating β in (26)) is c-commanded by X within its binding domain (here, the whole sentence), which by (26bii) thus cannot be its antecedent, i.e., the identity condition $Y = X$ is not an admissible resolving condition for the pronoun. This captures the noncoreference effect of BT(B), since the establishment of the pronoun's reference depends on its being equated with an antecedent by means of the identity condition; thus nonidentity amounts to

based, like Lasnik's theory, on disjoint reference.)

¹⁹ Kamp & Reyle formulate separate rules for singular and plural nonreflexive pronouns, chiefly, it seems, in order to account for the distributive reading of plural pronouns with quantifying antecedents, which requires the use of individual (i.e. atomic) discourse referents. Since this is independent of matters related to BT(B), we have not incorporated it into our account.

noncoreference.

Moreover, since the effect of BT(B) is not a constraint on reference per se, but rather on the admissibility of identity conditions, CR.PRO also covers cases of nonreferential (e.g. quantified) potential antecedents, where the pronoun is semantically a bound variable. We illustrate this with an analysis of (28a), which is ungrammatical under the intended reading that every student likes himself:

(28) a *Every student likes him.

b

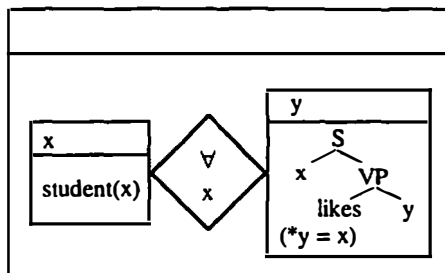

The treatment of quantification in DRT derives from generalized quantifier theory (see Kamp & Reyle 1993:314ff. for details). The construction rule for quantifying NPs introduces a tripartite condition (called a *duplex condition*, since it contains two DRSs as constituents). The diamond contains a specification of the quantificational force and the quantified discourse referent (which thus functions semantically like a variable), the lefthand DRS constitutes the first argument, or restrictive term, of the quantifier, and the righthand DRS the scope of the quantifier. As seen in (28b), the scope DRS contains a representation of the entire reduced sentence structure, while the content condition for the quantified subject occurs in the restriction DRS. Clearly, attempting to identify the quantified subject as the antecedent of the pronoun (by means of the condition $y = x$) would violate the resolution clause (bii) of CR.PRO, since the discourse referent x in subject position c-commands the discourse referent y in the position of the pronoun within its binding domain.²⁰

²⁰ The universe of the restriction DRS is by definition accessible (cf. footnote 10) from the scope DRS. The reason that the discourse referents for the quantified NP and the pronoun are introduced into the subDRSs, not the main DRS, is to account for the unavailability of anaphora to quantified antecedents outside of the quantificational scope, as in *Every man left early. He took the bus.

4.2 Are split antecedents subject to noncoreference restrictions?

Additional empirical motivation for analysing BT(B) effects at the level of DRSs comes from restrictions on anaphora to split antecedents. Recall from section 2.1 that there is a BT(B) effect with split antecedents, when each of the NPs constituting the split antecedent c-commands the pronoun within its binding domain. This is exemplified by (11), repeated here as (29a), which receives the DRS in (29b):

(29) a *Bill_{1} told Mary_{2} about them_{1,2}.

b

x	y	X	Y
Bill(x)	Mary(y)	x told y about X	Y = x⊕y X = Y

The formulation of CR.PRO in (26) permits the resolution condition $X = Y$, since Y , being introduced by Summation, does not even occur in the syntactic structure of the sentence, let alone c-command the pronoun within its binding domain. Thus, it is wrongly predicted that the group consisting of Bill and Mary should be an admissible antecedent for the pronoun. To avoid this consequence, the resolution clause of CR.PRO must be augmented with a condition prohibiting identification with a discourse referent introduced by the rule of Summation, just in case all of the NPs making up the 'sum' are both within the binding domain of the pronoun and c-command it.

However, it is not only the discourse referents introduced by the NPs occurring within the pronoun's binding domain that must be excluded from the resolution clause. Consider the following sentence (modelled on one suggested by Hans Kamp, p.c.), in which the embedded clause is structurally the same as (29a):

(30) *Bill_{1} and Mary_{2} said they_{1,2} told Fred_{3} about them_{1,2,3}.

The following composite DRS represents three attempted resolutions of the pronoun *them* in this sentence, given by the pairs of conditions in (i)-(iii), respectively (again abstracting away from the DRT treatment of propositional attitudes):

(31)

x y X Y z Z W V U Bill(x) Mary(y) $X = x \oplus y$ Fred(z) x and y said [Y told z about Z] $Y = X$ (i) $W = Y \oplus z$ (ii) $V = X \oplus z$ (iii) $U = x \oplus y \oplus z$ $Z = W$ $Z = V$ $Z = U$

On the analysis in (i), the identity condition $Z = W$ has the same effect as the condition $X = Y$ in (29b), and would be excluded by the restriction needed to account for (29a). However, on the analysis in (ii), since X by definition fails to c-command Z at all (*a fortiori* within its binding domain), that restriction would not prevent V from being the resolving discourse referent for Z . Likewise, on the analysis in (iii), while all three discourse referents x , y and z c-command the pronoun, only z does so within its binding domain (the bracketed constituent), so that the restriction would wrongly permit the condition $Z = U$.

The problem for (26) with the analyses of (30) in (31ii) and (31iii) is that the resolution clause of CR.PRO—also with the restriction mentioned above—fails to take into account the transitivity of identity. Although only Y and z c-command Z within the latter's binding domain, it is the identification of the sum of x and y with X , and of the latter with Y , that gives rise to the observed BT(B) effects. To account for this it is necessary to further restrict the resolution clause so as to exclude any discourse referent that is identified with a sum whose summands are collectively identified (in a sense to be made precise) with any (sum of) discourse referents c-commanding the pronoun within its binding domain.

The problem concerning the transitivity of identity is a general one in DRT, deriving from the association of each NP with a distinct discourse referent and the establishment of anaphoric relations between NPs through identity conditions over the corresponding discourse referents. Kamp & Reyle (1993:235-236) address this matter for simple cases involving singular pronouns, as in **John said he likes him*, where the discourse referents introduced by the pronouns are independently identified with the discourse referent introduced by the nonpronominal NP. They define equivalence classes of discourse referents occurring in identity conditions, and restrict CR.PRO by requiring in effect that a potential resolving discourse referent for a pronoun not be a member of the equivalence class of any discourse referent that c-commands the pronoun's

discourse referent within its binding domain.

However, their definition does not take into account the identification of a plural discourse referent with a sum of discourse referents under the Summation condition (though it does serve to construct equivalence classes of plural discourse referents under the identity condition). Since expressions of the form $\alpha_1 \oplus \dots \oplus \alpha_n$ are not themselves discourse referents, it would be both ad hoc and unintuitive to include them in the equivalence class. We propose instead to define equivalence classes of sets of discourse referents, among whose members will be the singletons of single discourse referents occurring on either side of an identity condition, as well as the set of 'summands' occurring on the righthand side of a Summation condition. In addition, to capture the transitivity of identity here, the latter must be constructed recursively from members of the equivalence classes of the individual 'summands'. Finally, in order to account for cases like (31iii), members of the equivalence class must include singletons of those discourse referents identified with a sum, which is itself part of a larger sum, whose summands are a member of the equivalence class. The following is a precise definition of this equivalence class:²¹

- (32) Given a discourse referent α occurring in a DRS K , the class of its *DRS-equivalents*, $[\alpha]_K$, is the smallest class Γ such that:
- (i) $\{\alpha\} \in \Gamma$;
 - (ii) for any discourse referents β and γ , if $\{\beta\} \in \Gamma$ and $\text{Con}K$ contains either $\beta = \gamma$ or $\gamma = \beta$, then $\{\gamma\} \in \Gamma$;
 - (iii) for any discourse referents $\beta, \gamma_1, \dots, \gamma_n$, if $\{\beta\} \in \Gamma$ and $\text{Con}K$ contains $\beta = \gamma_1 \oplus \dots \oplus \gamma_n$, then $\{\gamma_1, \dots, \gamma_n\} \in \Gamma$;
 - (iv) for any discourse referents $\beta_1, \dots, \beta_n, \gamma_1, \dots, \gamma_m$, if $\{\beta_1, \dots, \beta_n\} \in \Gamma$ and $\gamma_1 \in [\beta_1]_K, \dots, \gamma_m \in [\beta_m]_K$, then $\{\gamma_1, \dots, \gamma_m\} \in \Gamma$; and
 - (v) for any discourse referents $\beta_1, \dots, \beta_n, \gamma_1, \dots, \gamma_m$, and δ , if $\{\beta_1, \dots, \beta_n\} \in \Gamma$, $\{\gamma_1, \dots, \gamma_m\} \subseteq \{\beta_1, \dots, \beta_n\}$ and $\text{Con}K$ contains $\delta = \gamma_1 \oplus \dots \oplus \gamma_m$, then $\{\delta\} \cup (\{\beta_1, \dots, \beta_n\} - \{\gamma_1, \dots, \gamma_m\}) \in \Gamma$.

In terms of this definition, the restriction on CR-PRO is simply that no DRS-equivalent of a potential resolving discourse referent for a pronoun may be identical to the set of discourse referents that c-command the pronoun within its binding domain.

²¹ As shown in Berman & Hestvik (1994), it is necessary to extend the class of identified discourse referents to those used in defining the restrictive term of a quantifier; for reasons of space, we omit this case here.

To facilitate a concise formulation of this restriction, we introduce the following abbreviation:

(33) $BC(\alpha) =_{df} \{ \beta \mid \beta \text{ occurs within } \alpha\text{'s binding domain and } \beta \text{ c-commands } \alpha \}$

The final version of CR.PRO is now formalized in (34), where again clause (bii) contains the effect of BT(B):²²

(34) *CR.PRO* (final version)

If α is a nonreflexive pronoun in a syntactic structure S , carry out the following operations on the immediate DRS K in which α occurs:

- (a) Introduce a new discourse referent β , of the appropriate atomicity for α , into U_K and in Con_K substitute β for the syntactic structure consisting of α and its categorial projections.
- (b) Add to Con_K the condition $\beta = \gamma$, where
 - (i) γ is a suitable accessible discourse referent; and
 - (ii) $BC(\beta) \in [\gamma]_K$.

Let us see how this formulation of CR.PRO accounts for the BT(B) effects observed with split antecedents. Consider first the simple summation example in (29a). In its DRS (29b), $BC(X) = \{x, y\}$ and $[Y]_K = \{\{Y\}, \{X\}, \{x, y\}\}$ by (32i-iii); thus $BC(X) \in [Y]_K$, so $X = Y$ does not satisfy the resolution clause (37bii) and Y is not an admissible resolving discourse referent for X . Turning to (30), with the three analyses represented by the DRS in (31), we have $BC(Z) = \{Y, z\}$. This set turns out to be a member of each of the equivalence classes $[W]_K$, $[V]_K$, and $[U]_K$, of the respective candidate resolving discourse referents. For $[W]_K$, this follows directly from clause (iii) of (32), given the condition $W = Y \oplus z$. For $[V]_K$, it follows crucially from clause (iv) of (32), given the conditions $V = X \oplus z$ (making $\{X, z\} \in [V]_K$ by (32iii)) and $Y = X$. Finally, for $[U]_K$, the crucial clause is (32v), which, given the conditions $U = x \oplus y \oplus z$ and $X = x \oplus y$, makes $\{X, z\} \in [U]_K$, from which it follows by (32iv), given $Y = X$, that $\{Y, z\} \in [U]_K$. Consequently, each of the proposed resolving conditions in (31i-iii) is, correctly, inadmissible. We leave it as a straightforward exercise for the

²² The present formulation of the resolution clause differs slightly but significantly from that given in Berman & Hestvik (1994). Our earlier analysis, which employed equivalence classes of sets of discourse referents defined on the basis of Kamp & Reyle's definition of equivalence classes of discourse referents, failed to account for cases such as (31iii).

reader to verify that standard noncoreference cases like (25), as well as transitive cases like **John said he likes him*, also fall out as desired from (34).

This formulation of CR.PRO still correctly permits properly overlapping and inclusive reference between a pronoun and a c-commanding NP within the pronoun's binding domain. Consider for example (24). For the lowest pronoun, with discourse referent Y , $BC(Y) = \{w\} \in \{Z\}K = \{\{Z\}, \{Y\}, \{X\}, \{x, y\}\}$; therefore $Y = Z$ is admissible and overlap between the references of Y and w is sanctioned. For the pronoun corresponding to w , $BC(w) = \{X\} \in \{y\}K = \{\{y\}, \{w\}\}$, so $w = y$ is admissible and overlap between the references of w and X is sanctioned. We again leave it as an exercise for the reader to verify that analogous results hold for inclusive reference with plural pronouns, as in (15b,d).

5 The empirical status of local split antecedents

In contrast to Seely's judgment of (11) (= (29a)), Fiengo & May (1994:40) judge the following similar example (= their (116)) grammatical:

(35) John_{1} talked to Mary_{2} about them_{1,2}.

On the basis of this judgment, they conclude that there are no binding-theoretic restrictions on split antecedents and their analysis embodies this conclusion. In this regard their theory is equivalent to ours as stated in the preliminary version of CR.PRO in (26) but is less restrictive than our final version of CR.PRO in (34).

We in fact share both Seely's intuition about (11) and Fiengo & May's about (35). One explanation for the difference between these examples that immediately springs to mind is that the latter would not in fact be an instance of locally c-commanding split antecedents, if the NP *Mary* failed to c-command out of the PP; thus no BT(B) effect would be expected in (35). However, evidence that c-command does obtain here comes from the possibility of coreference between the prepositional object and a reflexive pronoun (i.e., there is no BT(A) effect), as in the following example (cf. Pollard & Sag 1992:(70b)):

(36) John talked to *Mary* about *herself*.

Thus, it seems reasonable to conclude that (35) is indeed a case of c-commanding split

antecedents, like (11). Significantly, we find that the difference between (11) and (35) with respect to BT(B) also obtains with singular pronouns (cf. Reinhart & Reuland 1993:(122)):

- (37) a John talked to *Mary* about *her*.
 b *John told *Mary* about *her*.

Finally, we note an apparent subject/object asymmetry with *talk to* but not with *tell*, as indicated by comparing the contrast in (37) with the uniform unacceptability of the following:²³

- (38) a **John* talked to *Mary* about *him*.
 b **John* told *Mary* about *him*.

Although we currently have no explanation for these observations, the nonuniform behavior of *talk to* suggests that the acceptability of (35) cannot by itself be taken as providing reliable evidence against the existence of BT(B) effects with local split antecedents. In contrast, the uniform behavior of *tell* provides consistent evidence in support of this. To further test this it is necessary to find other suitable predicates that behave uniformly. These must be (at least) three-place predicates, all of whose arguments have the same conceptual status (e.g. [+human]). Although a detailed empirical investigation is beyond the scope of this paper, initial consideration of (appropriately contextualized) sentences with verbs fulfilling these criteria tends to support, in our judgment, Seely's generalization that c-commanding local split antecedents induce a BT(B) effect. Consider the following example:²⁴

- (39) At their wedding reception, John and Mary were speaking to Bill and Sue.
 a John_i said that he_i wanted [PRO_i to photograph Mary for them].
 b John_i said that he_i wanted [Bill to photograph Mary for them].

²³ The same asymmetry obtains in cases involving Summation:

- (i) *John {1} and Mary {2} talked to Fred {3} about them {1,2}
 (ii) John {1} talked to Mary {2} and Fred {3} about them {2,3}

The corresponding examples with *tell* are, as expected, uniformly unacceptable.

²⁴ Although the *for*-PP is not an obligatory argument phrase here, it behaves as an argument with respect to binding theory, cf. *John* photographed *Mary* for *himself*?**him*.

In (39a) the most plausible resolution for the pronoun is Bill and Sue; John and Mary are not an acceptable resolution, as predicted by (34). In contrast, in (39b), John and Mary can be the antecedent of the pronoun. We find the same type of contrast with the following verbs: *assign to*, *deny to*, *cede to*, *compare to*, *consign to*, *entrust to*, *explain to*, *leave to*, *offer to*, *point out to*, *promise to*, *reveal to*. On the basis of such evidence we tentatively conclude, contra Fiengo & May, that split antecedents can induce BT(B) effects. This means that a uniform treatment of pronominal resolution must be sensitive to the way the potential antecedent arises. Therefore, the incorporation of BT(B) into the construction rule for pronouns should be as we have formulated it in (34).

Let us briefly reflect on this conclusion. If it stands up to further empirical scrutiny, it would constitute a convincing argument that the effect of BT(B) really belongs at the interface between syntax and semantics. On one hand, the locality constraint and the c-command requirement are clearly syntactic properties. On the other hand, that split antecedents should be subject to this constraint strongly supports a nonsyntactic aspect, since these do not constitute a single syntactic constituent, which would be required for establishing either a coreference or a noncoreference relation at a syntactic level. But at the discourse level, a single entity is available through Summation.

Even if further investigation should lead to the conclusion that local split antecedents do not induce a semantically hard BT(B) effect, we believe that our analysis (which should then be based on a version of CR.PRO similar to (26) but making reference to equivalence classes of discourse referents, to account for the transitivity of identity) provides the conceptually most appealing approach to pronominal anaphora. Consider a purely syntactic alternative, such as that offered by Fiengo & May (1994:39ff.). They employ a standard version of binding theory, mediated by syntactic indices. But in order to account for split antecedents, they must resort to complex indices. Rather than using set indices such as Lasnik (1986) advocated, they introduce the notion of a *fusion index*, using the notation $j\oplus\dots\oplus n$.²⁵ This is the index associated with a plural pronoun whose antecedent consists of the collection of NPs bearing the single indices j, \dots, n . Fiengo & May extend the definition of coindexation to accommodate fusion indices: i is coindexed with j, \dots, n iff $i = j\oplus\dots\oplus n$. That is, when one member of a coindexed pair bears a fusion index, the other member is a set of distinct syntactic constituents. It seems to us that this analysis is simply a way of forcing into strictly syntactic terms what is essentially a syntax-independent process—

²⁵ The identical notation for fusion indices and Summation is a coincidence, as far as we are aware.

namely, Summation. (Cf. also Chomsky's (1993:fn.53) comments on the theoretical dispensability of indices.) Since Summation is independently needed and motivated within DRT, we believe that replicating it in the syntax sheds no further light on anaphora resolution.²⁶

If our interpretation of BT(B) effects (which is essentially that of Seely 1993) is right, it also has consequences for certain theoretical claims about pronominal anaphoric relations. In particular, the impossibility of local split antecedents both of reflexive pronouns (on which there is consensus in the literature) and of nonreflexive pronouns (as we argue, following Seely), constitutes a direct argument against Burzio's (1989) theory of anaphora, which entails that nonreflexive pronouns can occur in any environment where reflexive pronouns are excluded. It also constitutes a somewhat more indirect argument against the approach of Reinhart (1983), according to which anaphora between a reflexive pronoun and a local antecedent involves syntactic binding. Hence, the impossibility of local split antecedents of reflexives indicates that there is no syntactic binding in this configuration. Therefore, anaphora between a nonreflexive pronoun and local split antecedents is also not a case of binding. But then Reinhart's theory predicts that coreference between a nonreflexive plural pronoun and c-commanding local split antecedents should be possible, which again we have argued to be incorrect.

²⁶ Possible indirect support for our approach might be seen in Reinhart & Reuland's (1993) argument that BT(B) should apply at a semantic level of representation that distinguishes the distributive and collective readings of certain predicates. As we show in Berman and Hestvik (1994), if Reinhart & Reuland's observations are correct, we can take them into account by augmenting our theory with a treatment of distributivity, proposals for which already exist within DRT (cf. Roberts 1987 and Kamp & Reyle 1993). However, we also provide data that call Reinhart & Reuland's conclusions into question. We suggest that the differential effects of distributivity on pronominal resolution are due to lexical semantic properties of the verbs involved, and thus should not be accounted for by the theory of pronominal resolution itself.

References

- Asher, Nicolas & Hajime Wada. 1988. A computational account of syntactic, semantic and discourse principles for anaphora resolution. *Journal of Semantics* 6. 309-344.
- Berman, Stephen & Arild Hestvik. 1994. Principle B, DRT and plural pronouns. Bericht Nr. 65, Arbeitspapiere des Sonderforschungsbereichs 340, University of Stuttgart.
- Burzio, Luigi. 1989. On the non-existence of disjoint reference principles. *Rivista di Grammatica Generativa* 14. 3-27.
- Chomsky, Noam. 1981. *Lectures on Government and Binding*. Dordrecht: Foris.
- Chomsky, Noam. 1986. *Knowledge of Language: Its Nature, Origin, and Use*. New York: Praeger.
- Chomsky, Noam. 1993. A minimalist program for linguistic theory. In Ken Hale & Samuel J. Keyser (eds) *The View from Building 20: Essays in Honor of of Sylvain Bromberger*. Cambridge, Mass.: The MIT Press. 1-52. [Reprinted in Chomsky 1995. 167-217.]
- Chomsky, Noam. 1995. *The Minimalist Program*. Cambridge, Mass: The MIT Press.
- Chomsky, Noam & Howard Lasnik 1993. The theory of principles and parameters. Joachim Jacobs, Arnim von Stechow, Wolfgang Sternefeld & Theo Vennemann (eds) *Syntax: A Handbook of Contemporary Research*. Berlin: De Gruyter. [Reprinted in Chomsky 1995. 13-127.]
- van Daele, Kees. 1992. Towards a generalization of anaphora. *Journal of Semantics* 9. 27-51.
- van Daele, Kees. 1994. What's new? A semantic perspective on sentence accent. *Journal of Semantics* 11. 1-32.
- Evans, Gareth. 1980. Pronouns. *Linguistic Inquiry* 11. 337-362.
- Fiengo, Robert & Robert May. 1994. *Indices and Identity*. Cambridge MA: The MIT Press.
- Heim, Irene. 1993. Anaphora and semantic interpretation: A reinterpretation of Reinhart's approach. SFS-Report-07-93, Seminar für Sprachwissenschaft, University of Tübingen.
- Hestvik, Arild. 1991. Subjectless binding domains. *Natural Language and Linguistic Theory* 9. 455-496.
- Hestvik, Arild. 1992. LF movement of pronouns and antisubject orientation. *Linguistic Inquiry* 23. 557-594.
- Kamp, Hans & Uwe Reyle. 1993. *From Discourse to Logic*. Dordrecht: Kluwer.
- Lasnik, Howard. 1976. Remarks on coreference. *Linguistic Analysis* 2. 1-22.
- Lasnik, Howard. 1981. On two recent treatments of disjoint reference. *Journal of Linguistic Research* 1.
- Lasnik, Howard. 1986. On the necessity of binding conditions. In: Robert Freidin (ed.) *Principles and Parameters in Comparative Grammar*. Cambridge, Mass: The MIT Press.
- Lasnik, Howard. 1989. *Essays on Anaphora*. Dordrecht: Kluwer.
- Lasnik, Howard & Juan Uriagereka. 1988. *A Course in GB Syntax*. Cambridge, Mass: The MIT Press.
- Pollard, Carl & Ivan Sag. 1992. Anaphors in English and the scope of binding Theory. *Linguistic Inquiry* 23. 261-303.
- Postal, Paul. 1966. A note on 'understood transitively'. *International Journal of American Linguistics* 32. 90-93.
- Reinhart, Tanya. 1983. *Anaphora and Semantic Interpretation*. Chicago: University of Chicago Press.

Reinhart, Tanya & Eric Reuland. 1993. Reflexivity. *Linguistic Inquiry* 24. 657-720.

Roberts, Craige. 1987. Modal subordination, anaphora, and distributivity. Dissertation, University of Massachusetts, Amherst.

Seely, T. Daniel. 1993. Binding plural pronominals. In: Katherine Beals *et al.* (eds) *CLS 29: Papers from the 29th regional meeting, Vol II*. Chicago: University of Chicago. 305-317.

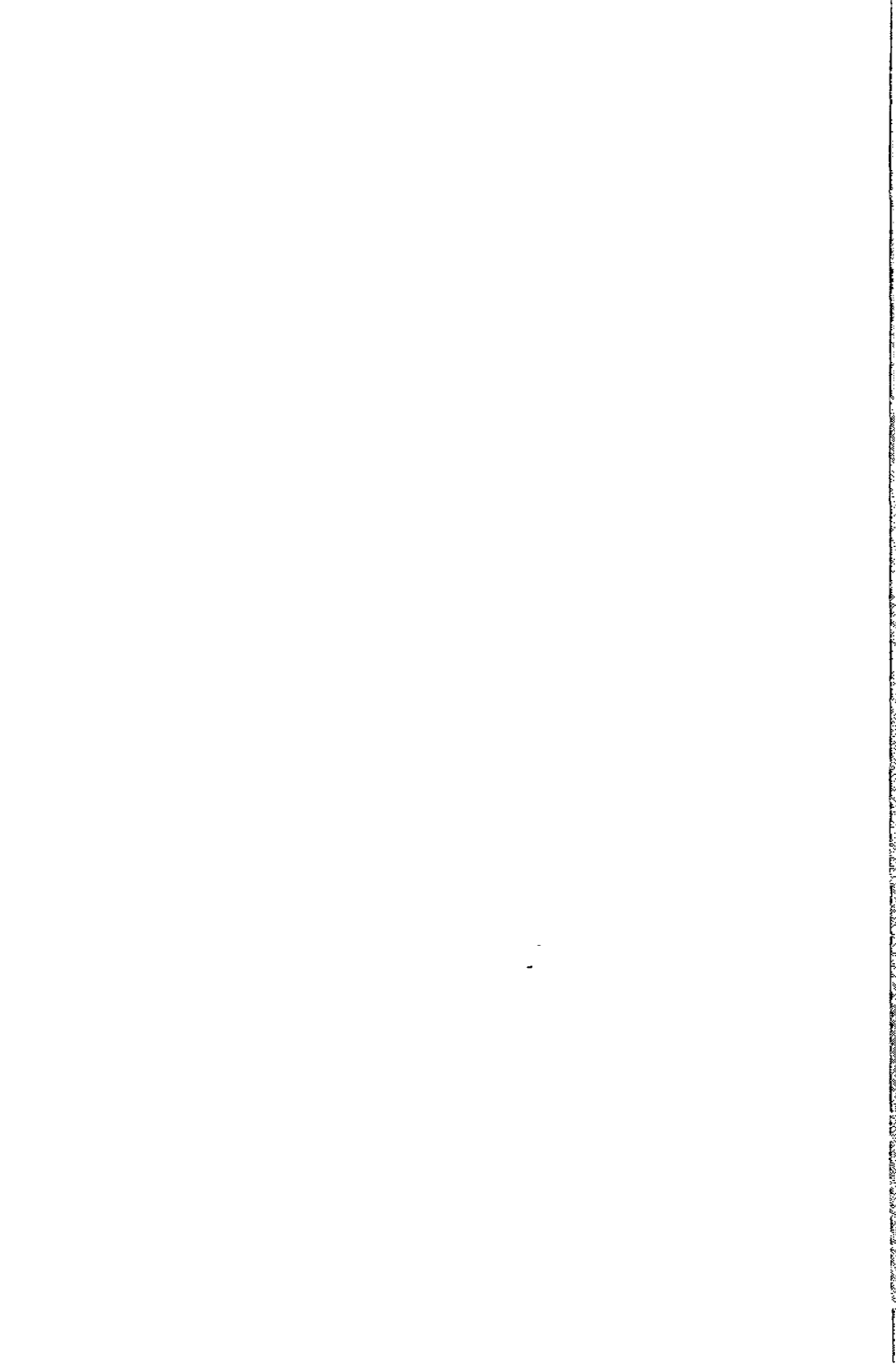

Binding Theory and Switch-Reference

George Aaron Broadwell

1 Introduction

Binding theory originates with the attempt to account for the interpretations of ordinary and reflexive pronouns. However, binding theory has also been extended to the analysis of a range of data beyond those that originally motivated it. Switch-reference, a grammatical phenomenon found in many Native American and Papuan languages, is one such domain.

In this paper, I will argue for three universal properties of switch-reference (hereafter SR) systems. First, SR is based upon the configurational properties of the sentence in which it appears; it is best explained through appeal to notions like A'-status and command rather than notions like argument or agency. Second, due to the configurational nature of SR, it is only found in subordinate clauses. Third, SR is always local and never long-distance. My arguments are based primarily on the Muskogean languages Choctaw and Chickasaw, but I believe that the properties described for these languages are characteristic of SR in general.

I will argue that these conclusions for SR systems have implications for the structure of binding theory. The interpretation of the pronominal data that originally motivated binding theory has become more complex with the recognition of interactions between purely structural notions like command and more semantic notions like agency and logophoricity.

In my view, SR systems present a more pristinely structural system of binding relationships than that found in pronominal binding, and for this reason examination of SR is important for distinguishing structural from non-structural effects in binding theory.

2 Basic assumptions

A typical instance of SR is shown in the following Choctaw examples:¹

- (1) John-at abiika-haatokoo-sh ik-iyy-o-tok.
 John-NOM sick-because-SS III-go-NEG-PT
 'Because John_i was sick, he, didn't go.'
- (2) John-at abiika-haatokoo-n ik-iyy-o-tok.
 John-NOM sick-because-DS III-go-NEG-PT
 'Because John_i was sick, he_j didn't go.'

In (1), the complementizer of the subordinate clause includes a SR marker indicating that the two clauses have the same subject (SS), while in (2) the subordinate clause is marked to show different subject (DS).

Finer (1984, 1985) analysed SR as an instance of A'-binding, treating the SS marker as an anaphor that must be bound by the Infl/Comp of the matrix clause, and the DS marker as a pronominal that must be free of this same Infl/Comp.² Since Infl (and according to Finer's assumptions, Comp) bears the index of the subject of the matrix clause, the observed distribution follows.

¹ In the Choctaw examples, orthographic symbols have their standard phonetic values, except that <sh> = [ʃ], <ch> = [tʃ], and <lh> = [tʃ]. Underlining shows vowel nasalization.

The Amele examples follow Roberts orthography. Note that <c> = [ʔ] and <q> = [g̃b].

The following abbreviations are used in the glosses: ACC=accusative, CAUS=causative, DS=different subject, FOC=focus, IRR=irrealis, L=l-grade, NEG=negative, NOM=nominative, O=object, POT=potential, PL.=plural, PRES = present, PT=past, S=subject, SS=same subject, TNS=tense.

² Finer treats Infl/Comp as the joint head of S'. In what follows, I use Infl as an abbreviation for some number of functional projections (presumably including Tns and Agr) when the specific content of these projections is not relevant.

A slightly modified version of Finer's assumptions is shown in figure 1.

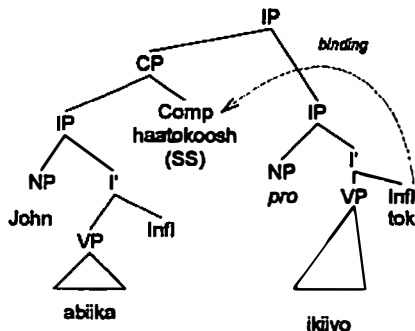

Figure 1 Tree structure for 'Because John, was sick, he, didn't go.'

This analysis requires a few assumptions about the operation of binding which should be made explicit. They include the following:

- Infl m-commands Comp because the first maximal projection set that dominates Infl also dominates Comp. M-command appears to be the relevant notion for SR binding, rather than c-command.
- The SR marker in Comp must bear the index of *John*. I'll assume that it receives this index via Spec-Head agreement with Infl (or Agr), and that Infl is incorporated into Comp, bringing this index with it.
- The classic definition of governing category (Chomsky 1981) says that the minimal binding domain for an anaphor must include the anaphor, an accessible SUBJECT, and an item governing the anaphor. If there is no domain that contains both a SUBJECT and a governor, then the anaphor is free in its reference. However, under my assumptions the binding domain for a SR marker must be the smallest maximal projection containing the SR marker and a potential A'-antecedent. Since SR markers canonically occur in ungoverned positions, including governor in the definition of the binding domain would wrongly predict that they are free in reference.

However, the original motivation for stipulating the presence of a governor in the definition of binding domain was somewhat questionable. The inclusion was intended to derive the distribution of PRO from the binding theory (in what is generally called the PRO theorem). Without discussing the controversy in any detail, it is sufficient to say here that there are several plausible alternatives to the binding-theoretic account of the distribution of PRO. I take the inclusion of governor in the definition of

binding domains to be unnecessary, and the fact that SR markers appear in ungoverned positions is unproblematic. These points are discussed in more detail in Broadwell (1990).

3 Universal properties of switch-reference

3.1 Switch-reference is configurational

By virtue of being A'-anaphors, SR markers need not be bound by arguments; they are sensitive only to A'-status and command relationships. In particular, there is little evidence to support the view that SR is sensitive to notions like argument or agency.

In the Western Muskogean languages Choctaw and Chickasaw, SR interacts with a rule of Possessor Raising (PR) in a way that shows that the antecedent of a SR marker need not be an argument of the matrix clause. Possessor raising extracts the possessor of the subject of an intransitive verb and adjoins it to the sentence; the raised possessor then receives nominative case. (3) shows a Chickasaw sentence without PR; (4) shows the same sentence after PR has applied. The Chickasaw data come from Munro and Gordon (1982) and Carden, Gordon, and Munro (1982).

- (3) John im-ofi'-at illi-h.
 John III-dog-NOM die-TNS
 'John's dog died.'
- (4) John-at ofi'(-at) im-illi-h.
 John-NOM dog(-NOM) III-die-TNS
 'John's dog died.'

I suggest that sentences like (4) have a structure like that shown in figure 2:

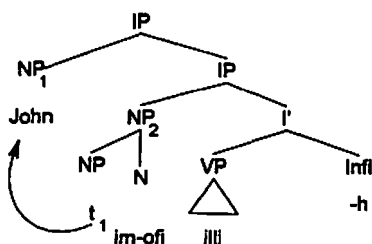

Figure 2 The structure of possessor raising

Nominative case is assigned configurationally to the [NP,IP] position, so both NP₁ and NP₂ may be marked nominative.³

In favor of the structure shown, there is evidence (due originally to Carden, Gordon and Munro (1982)) that NP₁ and NP₂ form a constituent in (3), but not in (4). Adverb placement is one constituency test in Chickasaw. Adverbs may intervene between a raised possessor and the possessed noun, but they may not intervene between a non-raised possessor and the possessed noun:

- (5) a Oblaashaash [John im-ofi'-at] illi-tok.
 yesterday John III-dog-NOM die-PT
 'Yesterday John's dog died.'
- b *John oblaashaah im-ofi'-at illi-tok.
- (6) a Oblaashaash [John-at] [ofi'-at] im-illi-tok.
 yesterday John-NOM dog-NOM III-die-PT
- b ✓John-at oblaashaash ofi'-at im-illi-tok.
 John-NOM yesterday dog-NOM III-die-PT

Sentences with both PR and SR are important for showing that binding of the SR marker is not limited to arguments of the matrix clause. Consider the following example:

³ I will leave the question of the position of the III-prefix on the verb open, since nothing in the argument here crucially relies on it. For one approach to the problem see Schütze (1994).

- (7) John-at ofi'-at im-ambiika-tok [sa-kisili-tokat].
 John-NOM dog-NOM III-sick-PT 1SII-bite-when:SS
 'John_i's dog_j was sick when he_i/it_j bit me.'

John is not an argument of the matrix clause. However, it is among the potential antecedents of the SS marker in the subordinate clause, by virtue of appearing in an A'-position.

Crucially, if PR had not applied in (7), the interpretation of the sentence would be different:

- (8) John im-ofi'-at abiika-tok [sa-kisili-tokat].
 John III-dog-NOM sick-PT 1sII-bite-when:SS
 'John_i's dog_j was sick when it_j/*he_i bit me.'

Because the possessor *John* is still contained within the subject, it is unable to c-command the SR marker in the adverbial clause, and the subject *John's dog* is the only possible antecedent for the SS marker.

Sentences like (7) have a structure like that shown in figure 3.

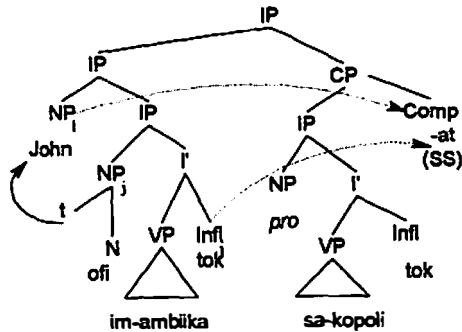

Figure 3 Tree diagram for (7)

Sentences like these are problematic for approaches that treat SR data through an appeal to semantic notions like argument or agent. Stirling (1993) is one such treatment. She gives a treatment of SR in which it is treated as "a kind of clause-level agreement, which normally marks the clause it occurs in as syntactically and semantically dependent, and indicates whether there is continuity or discontinuity

between the eventuality described by the marked clause and that described by the controlling clause." (p. 123)

Stirling's approach is couched within the framework of Unification Categorical Grammar, combined with Discourse Representation Theory. Within this approach, each clause is associated with a 'structured eventuality index' which contains three parameters: the Protagonist (defined as the agentive subject), the Actuality (realis or irrealis), and the Location. SS constrains the matrix and embedded clauses to agree in their eventuality parameters; DS indicates disagreement in at least one of the eventuality parameters.

However, Stirling's claim that SS signals coreferentiality of agents cannot be maintained, since in sentences like (7), *John* is not the agent, or even an argument, of the matrix clause.

In general, approaches to anaphora which treat the reflexive as a valency-decreasing operation on predicates (Keenan 1987) or a function imposing a identity restriction on arguments of a predicate (Reinhart and Reuland 1993) do not extend easily to SR systems. SR is canonically a relationship between NPs associated with different predicates, and the Chickasaw evidence shows that SR markers need not even be bound by arguments.

In contrast to the predicate-based approaches to anaphora, a purely structural account in terms of command relationships extends naturally to the SR data.

3.2 Switch-reference requires m-command

Configurations in which SR markers occur are limited to those in which the SR marker of a subordinate clause is m-commanded by an A'-position in the matrix clause; in particular, SR does not occur between coordinate clauses.

This is a crucial point in the analysis of SR. Several descriptions of SR data have suggested that SR markers occur in structures like that in figure 4. Roberts (1988) has argued for a structure of this sort in the Papuan language Amele, and claims that the appearance of SR markers in such a context is an argument against the binding theoretic treatment of SR.

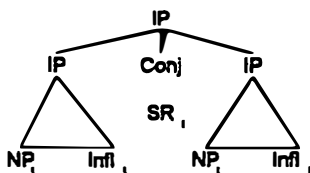

Figure 4 SR in a coordinate structure

In such a structure, the SR marker would bear the index of the first conjunct. Binding of the SR marker would be problematic if considered from a structural point of view. In general, we do not want command to hold between conjoined elements, given the ungrammaticality of examples like **I saw John_i and himself_i*.⁴ Since the occurrence of SR in coordinate contexts presents for binding-theoretic approaches to SR, it is important to examine such cases. In this section, therefore, I will argue that the tree in figure 4 does not in fact represent the correct structure of sentences containing SR markers.

3.2.1 Clause chains in Choctaw

The Choctaw examples in (9) and (10) are instances of a construction often called 'clause-chaining'. This is the most frequent environment for SR in Papuan languages, and clause chains are frequently analysed as coordination by researchers in that area.

Although Choctaw examples like (9) and (10) below are translated by coordination in English, more careful analysis shows that the clause containing the SR marker is subordinate to the following clause (Linker 1987, Broadwell 1990).

(9) John-at hiilha-chah taloowa-tok.

John-NOM dance:L-SS sing-PT

'John danced and sang.'

(10) John-at hiilha-nah taloowa-tok.

John-NOM dance:L-DS sing-PT

'John danced and (someone else).'

⁴ Multiple instances of a category in a conjoined structure appear to have a quite distinct status from the multiple instances that are the result of adjunctions. While m-command does extend into adjoined adverbial clauses, the available evidence seems to show that it does not extend into conjoined clauses.

There are several pieces of evidence to suggest that /-chah/ and /-nah/ are not coordinating conjunctions in Choctaw. They contrast with true coordinating conjunctions in the following ways:

a) The SR clause may not be independently marked for tense; truly coordinate clauses may be independently marked for tense:

- (11) *John-at hilha-tok-nah Bill-at taloow-aachih.
 John-NOM dance-PT-DS Bill-NOM sing-IRR
 'John danced and Bill will sing.'
- (12) John-at hilha-tok angti Bill-at taloow-aachih.
 John-NOM dance-PT and Bill-NOM sing-IRR
 'John danced and Bill will sing.'

b) There is no Coordinate Structure Constraint effect for the SR clauses, but the effect is found with a true coordinate conjunction like *angti*:

- (13) Katah-oosh_i John-at taloowa-nah t_i hilhah?
 who-FOC:NOM John-NOM sing:L-DS dance
 'Who_i did John_j sing and t_i dance?'
- (14) *Katah-oosh_i John-at taloowa-tok angti t_i hilha-tok?
 who-FOC:NOM John-NOM sing-PT and dance-PT
 'Who_i did John_j sing and t_i dance?'

These examples show that despite the fact that Choctaw sentences with both *angti* and SR markers are translated with 'and', there are real differences in the structures associated with them. We should be cautious about assuming coordinate structures in other languages based merely on the translation. I will suggest in the following section that despite the translations, the Amele sentences do not show true coordination.

3.2.2 Clause chains in Amele

Roberts (1988) is the most sustained attempt to defend an analysis of clause-chaining as coordination in a Papuan language. His most convincing argument is the following: clear cases of subordinate clauses show some flexibility in their order with respect to the main clause — they may precede the main clause, follow the main clause, or

occur between the subject and the predicate of the main clause, as shown in the following examples:

- (15) [Ho qo-qag-an nu]_{CP} dana age ho-ig-a.
 pig hit-3P-FUT purpose men 3p come-3P-PT
 'The men came to kill the pig.'
- (16) Dana [ho qo-qag-an nu]_{CP} age ho-ig-a.
 men pig hit-3P-FUT purpose 3P come-3P-PT
 'The men came to kill the pig.'
- (17) [Ija ja hud-ig-en fi] uqa sab man-igi-an.
 I fire open-1S-FUT if 3S food roast-3S-FUT
 'If I light the fire, she will cook the food.'
- (18) Uqa sab man-igi-an [ija ja hud-ig-en fi].
 3S food roast-3S-FUT I fire open-1S-FUT if
 'She will cook the food if I light the fire.'

Clause-chains don't have the same freedom of occurrence: they must always precede the main clause:

- (19) [Ho busale-ce-b] dana age qo-ig-a.
 pig run:out-DS-3S man 3P hit-3P-PAST
 'The pig ran out and the men killed it.'
- (20) *Dana [ho busale-ce-b] age qo-ig-a.
 man pig run:out-DS-3S 3P hit-3P-PAST
 'The pig ran out and the men killed it.'
- (21) *Dana age qo-ig-a [ho busale-ce-b].
 man 3P hit-3P-PAST pig run:out-DS-3S
 'The pig ran out and the men killed it.'

3.2.3 The structure of Choctaw clause chains

Choctaw clauses in /-chah/ and /-nah/ show the same ordering restrictions discussed by Roberts for Amele:

- (22) John-at hiilha-nah Bill-at taloowa-tok.
 John-NOM dance:L-DS Bill-NOM sing-PT
 'John danced and Bill sang.'

- (23) *Center-embedded*
 *Bill-at [John-at hiilha-nah] taloowa-tok.
 Bill-NOM John-NOM dance:L-DS sing-PT
- (24) *Extraposited to the right*
 *Bill-at taloowa-tok [John-at hiilha-nah].
 Bill-NOM sing-PT John-NOM dance:L-DS

I suggest that the key to understanding these clause-chaining structures in Choctaw and Amele lies in the nature of Tense in such sentences. Familiar instances of Tense can be thought of as predicates that take an event as argument, e.g. *Past* (kiss (pat, sandy)).⁵

What is distinctive about the clause chaining construction is that the clauses joined in this manner necessarily mirror their temporal order. This is obviously not true of ordinary adverbial clauses (*Because I am going to England, I have bought some guide books.* vs. *Because I went to England last year, I will go again next year.*)

In clause chains, the Tense predicate is transitive, taking two events as arguments: *Precede* ((dance(john)), (sing(hill))). This results in a phrase structure like the following:

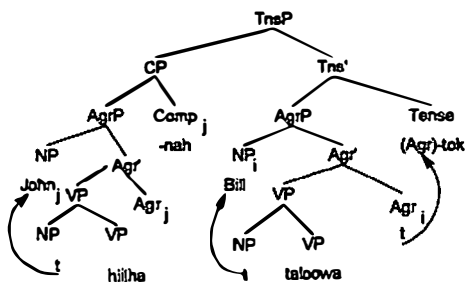

Figure 5 The structure of clause chaining in Choctaw

Given this structure, several correct predictions follow:

- The first clause of the chain occurs in a [Spec, TP] position. It cannot occur to the right of the second clause because right-edge specifier positions are unavailable in the language.
- The center-embedded construction is also unavailable since there is no position for the subject of the second clause (*Bill*) to move to.

⁵ If it is correct to say the the subject of an ordinary declarative sentence occupies the [Spec, TP] position, then we may view this as an instance of raising.

c) Given the lack of a Tns projection internal to either of the two events, it is impossible for them to have distinct tense specifications — they are always interpreted with the same tense.

This structure also preserves the c-command relationship between the Agr/Tense of the main clause and the SR marker.

3.2.4 Clause chains and reflexive movement

Additional evidence for the posited structures come from reflexive movement. In Choctaw, a reflexive subject of an embedded complement clause optionally moves onto the verb of the matrix clause:

- (25) John-at [ili-pisachokma-kat] anokfillih.
 John-NOM REFL-goodlooking-SS think
 'John_i thinks that self_i is goodlooking.'
- (26) John-at [pisachokma-kat] il-anokfillih.
 John-NOM goodlooking-SS REFL-think
 John_i self_i-thinks that t_i is goodlooking
 'John_i thinks that he_i is goodlooking.'

I proposed in Broadwell (1988) that this rule of reflexive movement is the S-structure reflex of the LF process suggested by Pica (1987) and others.

Reflexive movement only operates out of complement positions, not adjunct positions.

- (27) John-at (*ili-)yaayah [*pro* sipokni-haatokoosh].
 John-NOM (REFL-)cry old-because:SS
 'John (*self-)cried because he is old.'

Therefore, reflexive movement is a test for the complement status of a clause.

Choctaw has a few psychological verbs that select for complements with /-chah/ or /-nah/ marking:

- (28) Pam-at noklhak_acha-tok [Charles-at taloowa-nah].
 Pam-NOM surprise-PT Charles-NOM sing:L-DS
 'Pam was surprised that Charles sang.'

Such complements may appear either before or after the main verb (unlike the instances in clause chains):⁶

- (29) Pam-at [Charles-at taloowa-nah] noklhak_gcha-tok.
 Pam-NOM Charles-NOM sing:l-DS surprise-PT
 'Pam was surprised that Charles sang.'

Reflexives may move out of such complement clauses:

- (30) Charles-at ili_i-noklhak_gcha-tok [t_i abiika-chah].
 Charles-NOM REFL-surprise-PT sick-SS
 'Charles_i was self_i-surprised that t_i got sick.'

However, reflexive movement out of the clause-chaining version of such clauses is ungrammatical:

- (31) John-at sipokni-chah (*ili-)now-ahii-kiiyoh.
 John-NOM old-SS (*REFL-)-walk-POT-NEG
 'John is old and can't (*self-)walk.'

On the account given here, the contrast between (30) and (31) reduces to a familiar subject/object asymmetry. The ungrammatical example in (31) is an attempt to move the reflexive out of the subject position of the chaining Tense.⁷

4 Variation in switch-reference systems

Observed variation in SR systems can be reduced to variation in just two areas: i) the pronominal/disjoint anaphor distinction, and ii) whether SR markers must be bound at S-structure or whether binding at other levels is allowed.

⁶ Rightward extraposition seems to be more frequent for these complement clauses than for ordinary complement clauses. I don't have an explanation for this fact.

⁷ Note, however, that the structure given for possessor raising earlier would also seem to involve movement out of a subject constituent. Some explanation must be given for the differential grammatical status of the two examples.

4.1 DS as a pronominal vs. DS as a disjoint anaphor

The notion of *disjoint anaphor* (DIS) was first introduced by Saxon (1984) in the description of the Athapaskan language Dogrib. Consider the following examples:

- (32) John ye-hk'e ha.
 John 3DIS-shoot FUT
 'John_i is going to shoot him_j, ..'

/ye-/_i as a disjoint anaphor, must have an index distinct from that of the NP which c-commands it. It differs from a pronominal in occurring only in positions where a counterindexed antecedent is available. Thus the following instance in subject position is ungrammatical:

- (33) *?ekaani ye-enda.
 thus 3DIS-live
 'He lives this way.'

We may implement the condition on disjoint anaphors as follows: A disjoint anaphor bearing the index *i* must be c-commanded by an NP bearing the index *j*, where $i \neq j$.

There is good reason to think that the Choctaw and Chickasaw DS marker is a disjoint anaphor, rather than a pronominal. Consider the following example:

- (34) John-at ofi'-at im-ambiika-tok [sa-kisili-toka].
 John-NOM dog-NOM III-sick-PT 1SG-bite-when:DS
 'John_i's dog_i was sick when he_i/it_i bit me.'

This sentence has a structure like the following:

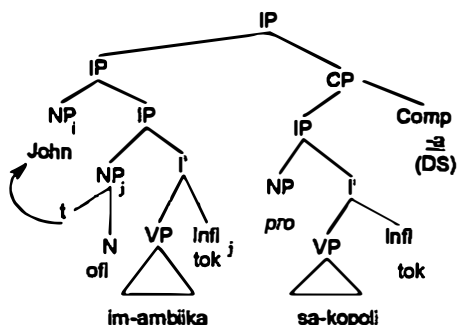

Figure 6 An example of DS marking in a possessor raising construction

If the DS marker were a pronominal, it would have to be free of all c-commanding antecedents. However, a disjoint anaphor only needs to be c-commanded by one NP with a distinct index. Since the *pro* subject of the embedded clause may be either 'dog' or 'John', the DS marker must be a disjoint anaphor.

However, other languages show evidence that DS markers are sometimes pronominals. Consider the following example from Amele (Papuan).

- (35) Age ceta **gul-do-co-bil** l-i bahim na tac-ein.
 3P yam **carry-3sO-DS-3PS** go-SS floor on fill-3PS:PT
 'They carried the yams on their shoulder and went and filled up the yam store.'

DS marking in this context is unexpected. Consultants say that in such cases "something has changed" or "this is a new situation".

In the usual situation, we assume that adverbial clauses are adjoined directly to the matrix clause, as in the following figure:

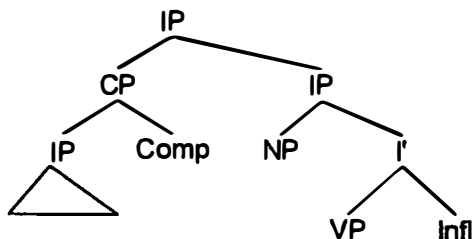

Figure 7 Typical configuration for SR marking of adverbial clauses

In such a configuration, the binding category for a DS marker typically extends into the matrix clause, assuming that Infl m-commands Comp. Therefore, a pronominal DS will need to be disjoint from A'-elements with the matrix IP.

However, the presence of a boundary stronger than that of adjunction would block command from Infl. In particular, adjunction to a matrix CP (rather than IP) would result in the ability of a pronominal SR marker to be free. Consider a structure like the following, where X = Comp (order irrelevant):

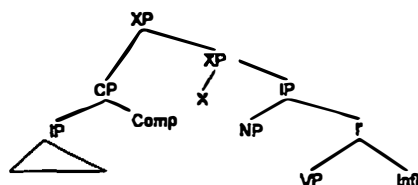

Figure 8 Possible structure for anomalous DS examples in Amele

In such a configuration, Infl does not m-command Comp, and a pronominal in Comp is free to occur, even if coindexed with Infl. Alternately, X in such a structure may be a null temporal or logical predicate or some other such functional element.

4.2 S-structure binding

A second parameter of variation for SR systems is found in the level at which the SR markers must be bound. Most SR languages seem to require S-structure binding. Some, however, show evidence for D-structure or LF binding.

The agreement system of Choctaw distinguishes between types of agreement labelled I, II, III.⁸ I is typically used for agentive subjects; II is used for the objects of transitives and subjects of unaccusatives:

- (36) a Baliili-lih. 'I run.'
 run-1SI
 b Sa-pisah. 'He sees me.'
 1SII-see

⁸ Some authors call these nominative, accusative, and dative, respectively. I avoid these terms since Choctaw has real case marking on noun phrases, and the I/II/III agreement on verbs need not match that on the noun phrase.

- c Sa-niyah. 'I'm fat.'
 1sII-fat

Despite the occurrence of object-like agreement on the subjects of unaccusative verbs, when an overt subject noun phrase appears it always takes the nominative case:

- (37) Anakoosh sa-niyah. 'I am fat.'
 I:NOM 1sII-fat

These facts suggest an unaccusative analysis, where *I* originates as the object of *fat* at D-structure, triggering agreement at that level. The NP then moves into subject position and receives nominative case.

For all the Choctaw speakers I have consulted, subjects of unaccusatives function like any other subject for the SR system:

- (38) Takkon laawa-ka aapa-chah niya-tok.
 apple lots-ACC eat:l-SS fat-PT
 'He ate lots of apples and got fat.'

However, Davies (1986) reports that for some speakers of Choctaw, unaccusative verbs license DS marking for subordinate clauses with coreferential subjects, as in the following example:

- (39) [John-at takkon aapa-nah] abiika-tok.
 John-NOM apple eat-DS sick-PT
 'John ate the apple and got sick.'

The verb in the matrix clause is unaccusative, and because the subject is null at D-structure, it is able to bind the DS marker in the embedded clause. However, most Choctaw speakers find examples like this ungrammatical, and all speakers prefer SS marking in this example. We may account for the diversity of judgments by claiming that some speakers of Choctaw allow binding of SR markers at either D- or S-structure, while others allow such binding only at S-structure.

Languages such as Amele (Roberts 1987, 1988) may also show evidence for binding of SR markers at other syntactic levels. Amele has a construction described as the impersonal, as shown in the following example:

- (40) Ija wen te-Ø-na.
 I hunger 1S-3S-PRES
 'I am hungry.'

The characteristic of this construction is that the experiencer NP appears first in the clause, followed by a NP which refers to a sensation or emotion. The appropriate object agreement for the experiencer is combined with 3rd singular agreement and the appropriate tense morpheme. There is no overt verb.

Roberts (1987:315ff) analyses the experiencer in such constructions as the object of the sentence, based on the fact that it triggers object agreement. However, there are two facts that suggest that this analysis may be mistaken.

First, the order shown above is invariant. If Roberts' analysis is correct and the experiencer is the object, then the obligatory word order for this construction is OSV, while the language is generally SOV.

Second, SR treats the experiencer as the subject in such constructions (Roberts 1987:300):

- (41) Ija b-i-m-ig wen te-i-a.
 I come-up-1SS-ss hunger 1SO-3S-PT
 'I came up and became hungry.'

If Roberts is correct in treating *hunger* as the surface subject of the second clause, then the SS marking is anomalous at S-structure. We would need to posit an analysis where the experiencer NP occupies the subject position, presumably at LF.

However, the Choctaw data above show that the mere appearance of object agreement on a verb is no firm assurance that the coindexed argument is in an object position at S-structure. Amele has no Case-marking, but the word order may indicate that experiencers are indeed subjects of the impersonals which trigger anomalous object agreement.

References

- Broadwell, George A. 1988. Reflexive movement in Choctaw. *Proceedings of NELS 18*. Amherst, Massachusetts.
- Broadwell, George A. 1990. Extending the binding theory: A Muskogean case study. Ph.D. thesis. UCLA.
- Carden, Guy, Lynn Gordon, & Pamela Munro. 1982. Raising rules and the Projection Principle. Manuscript. UCLA.
- Chomsky, Noam. 1981. *Lectures on government and binding*. Dordrecht: Foris.
- Davies, William. 1986. *Choctaw verb agreement and universal grammar*. Dordrecht: Reidel.
- Finer, Daniel. 1984. The formal grammar of switch-reference. Ph.D.thesis. University of Massachusetts, Amherst.
- Finer, Daniel. 1985. The syntax of switch reference. *Linguistic Inquiry* 16. 35-55.
- Keenan, Edward. 1987. On semantics and the binding theory. In J. Hawkins (ed.) *Explaining language universals*. Oxford: Blackwell.
- Munro, Pamela & Lynn Gordon. 1982. Syntactic relations in Western Muskogean: A typological perspective. *Language* 58. 81-115.
- Linker, Wendy. 1987. On the coordinating status of *-chah* and *-nah* in Choctaw. In P. Munro (ed.) *Muskogean linguistics* [= UCLA Occasional Papers in Linguistics 6]. UCLA.
- Pica, Pierre. 1987. On the nature of the reflexivization cycle. *Proceedings of NELS 17*.
- Reinhard, Tanya and Eric Reuland. 1993. Reflexivity. *Linguistic Inquiry* 24. 657-720.
- Roberts, John R. 1987. *Amele*. London: Croom Helm.
- Roberts, John R. 1988. Amele switch-reference and the theory of grammar. *Linguistic Inquiry* 19. 45-63.
- Saxon, Leslie. 1984. Disjoint anaphora and the binding theory. *Proceedings of the West Coast Conference on Formal Linguistics* 3.
- Schütze, Carson. 1994. Case, agreement, and switch reference in Choctaw: A minimalist approach. Manuscript. MIT.
- Stirling, Leslie. 1993. *Switch-reference and discourse representation theory*. Cambridge: Cambridge University Press.

Condition C

Hamida Demirdache

Introduction*

Under a 'universalist' approach to anaphora (Safir 1995), both Condition A effects and cross linguistic variation in the domain of Condition A are determined by semantic properties of anaphors. On the basis of anaphora in St'át'imcets (Lillooet Salish, henceforth ST'), I make the same case for Condition C. Both Condition C effects and cross linguistic variation in the domain of Condition C are determined by semantic properties of noun phrases.

I first establish cross linguistic variation in the domain of Condition C. I show that the domain of condition C in ST' is restricted: coreference anaphora within a clause respects Condition C whereas coreference across a clause violates Condition C, as established by Davis (1993) and Matthewson (1993). Bound variable anaphora, in contrast, never violates Condition C. I reduce cross linguistic variation in the domain of Condition C to a cross linguistic difference in the semantics of noun phrases: DPs in ST' are not presuppositional (or quantificational, in the sense of Milsark 1977). I then correlate the anaphoric properties of DPs in ST' with those of focussed and deictically used expressions in English, both of which also induce Condition C violations. I conclude that Condition C effects are *universally* determined by the semantic properties of noun phrases.

The analysis defended here supports Reinhart's (1983) thesis that Binding Theory only restricts bound variable anaphora. Coreference anaphora, however, is not governed by a pragmatic rule as proposed by Reinhart. I argue that the grammar does

* I thank Henry Davis for invaluable help and discussion, Mark Baker for detailed and significant comments on a previous version of this paper, Michael Rochemont for discussion of the material in sections 9.1, Lisa Matthewson and M. Dale Kinkade. I am indebted to Beverley Frank, Gertrude Ned, Rose Whitley and Laura Thevargé for their generosity with their time and their judgments. This research was partly supported by SSHRCC grant #410-95-1519.

not rule out a given coindexation relation: it rules out *all* the impossible interpretations of this coindexation. Coindexation is either free or filtered out by the principle that governs bound variable anaphora.

1 Preliminaries: St'át'imcets (Lillooet Salish)¹

I first summarize certain aspects of the syntax of ST' that will be relevant to the argumentation. Unmarked word order is VOS, as shown in (1a).² DPs are optional and marked by obligatory pronominal affixes on the predicate, as in (1b) and (2). ST' is morphologically split-ergative: third person arguments are inflected on an ergative-absolutive pattern as in (1), whereas first and second person arguments are inflected on a nominative-accusative pattern, as in (2).³

- | | | | | | | | |
|-----|---|------------------------|-------------|------------------------|---|------------|--------------|
| (1) | a | áts'x-en-Ø-as | ti sqáycw-a | ti máw-a | b | qwatsáts-Ø | |
| | | see-TR-ABS-ERG | DET man-DET | DET cat-DET | | left-3ABS | |
| | | 'The cat saw the man.' | | | | | 'S/he left.' |
| | | | | | | | |
| (2) | a | qwatsáts-kacw | b | áts'x-en-ts-kacw | | | |
| | | leave-2SG.SUB | | see-TR-1SG.OBJ-2SG.SUB | | | |
| | | 'You left.' | | 'You saw me.' | | | |

Word order in ST' is not free. First, scrambling to a pre-predicate position is restricted to QPs. Second, if word order was free, then (1a) should have either a VSO or a VOS

¹ St'át'imcets is a Northern Interior Salish language of the southwest mainland BC. It has two dialects: the Lower Mount Currie dialect and the Upper dialect spoken near Sat' (Lillooet). The dialect presented in this section is the Upper dialect (see footnote 2).

² In the Lower Mount Currie dialect, the unmarked order is VSO and VOS is marginal. The One-Nominal Interpretation in (3c) holds in both dialects and, more generally, across Salish languages.

Abbreviations used: 1, 2, 3 = 1st, 2nd, 3rd person, M = masculine, F = feminine, SG = singular, PL = plural, TR = transitive, SUB = subject, OBJ = object, ABS = absolutive, ERG = ergative, ERG.EXTR = ergative extraction, FUT = future, PROG = progressive, NOM = nominalizer, APPL = applicative, DEIC = deictic, QUOT = quotative, REFL = reflexive, DET = determiner, DET.ABS = absent determiner, FOC = focus, CONJ = conjunctive, NEG = negation, LINK = linker.

³ Note that the absolutive (i.e. 3rd person subject of an intransitive or 3rd person object of a transitive) marker is phonetically null. For expository reason, I omit the null absolutive marker from the ST' examples, unless its presence is relevant to the argumentation.

- (4) a *áts'x-en-as* *kw-s-Bucky* b 'He₁ saw Bucky₂'
 see-TR-ERG *DET-NOM-Bucky*
 c *'Bucky₁ saw him_{1/2}.' → **ONI*
 d *'He₁ saw Bucky₁.' → **Condition C*

In contrast, coreference outside the domain of the minimal clause is not subject to Condition C. Thus, (5a) can have either of the interpretations in (5b): the matrix subject is free to corefer with either the internal or the external argument of the embedded verb. Both these interpretations violate Condition C.⁶

- (5) a [_{IP} *tsut* [_{CP} *kw-s* [_{IP} *áts'x-en-as ti sqáycw-a kw-s Wany*]
 say *DET-NOM* *see-TR-ERG* *DET man-DET* *DET-NOM Wany*
 b 'He₁ said W. saw the man₁.' c She₂ said Wany₂ saw the man.'

Matthewson (1993) gives a number of strategies to ensure that the offending R-expression in (5a) is interpreted within the complement clause. The first test is to cleft the antecedent within the subordinate clause, as shown in (6). A clefted NP obligatory follows the focus marker *niłh*. The clefted nominal *Wany* in (6a) is, thus, unambiguously interpreted within the complement clause. It can nonetheless be A-bound by the matrix subject, as in (6b).

- (6) a [_{IP} *sqwál'-en-as s-Bucky* [_{CP} *kw-s [niłh s-Wany ta qwatsáts-a*
 say-TR-ERG *NOM-B.* *DET-NOM* *FOC* *NOM-W.* *DET leave-DET*
 b 'She₁ told Bucky that it's Wany₁ that left.'

A second strategy is to give the matrix and the complement clauses distinct temporal interpretations. The offending R-expressions in (7a) are unambiguously interpreted within the subordinate clause since they occur between the subordinate predicate and the adverbial which fixes its temporal reference. Coreference with the matrix subject is

⁶ The subject pronoun can also refer to some third person, known from the previous context (e.g. She₃ said Wany₂ saw the man₁). For expository reasons, this reading will not be indicated in the examples, unless it is relevant to the argumentation.

nonetheless free. In (8), we see that DPs embedded in a relative clause are also exempt from Condition C.⁷

- (7) a *tsut kelh* [_{CP} kw-s [_{IP2} cwfl'-en-as ti sqáycw-a s-Wany *inátcwas*
 say FUT DET-NOM look-TR-ERG DET man-DET NOM-W. yesterday
 b 'S/he_{1/2} will say that Wany₁ was looking for the man₂ yesterday.'
- (8) a *áts'x-en-as* [_{DP} ti tawen-táli-ha ti sqáycw-a ti máw-a]
 see-TR-ERG DET sell-ERG.EXT-DET DET man-DET DET cat-DET
 b 'He₁ saw the one who sold the man₁ the cat.'

In sum, a DP embedded within a complement or a relative clause may be A-bound in violation of Condition C.⁸ I now present and reject two hypotheses that have been proposed to account for the restricted domain of Condition C.

3 Two hypotheses

3.1 Hypothesis #1: the Pronominal Argument Hypothesis (PAH)

Under the PAH (Baker 1993, Jelinek 1984), an overt nominal is base-generated in an A'-position and binds a pronominal argument in an A-position. The PAH excludes the coreferential interpretation in (9b) as a Condition B violation.

⁷ Note that *ti sqáycw-a* 'the man' in (8) must be in object position. This is the case because the object of a verb in a relative clause cannot be separated from the verb, as the contrast between (ii) and (iii) demonstrates.

- (i) [_{IP} áts'x-en-as [_{DP} ti núk'w7-an-táli-ha ti sqáycw-a] kw-s Wany]
 see-TR-ERG DET help-TR-ERG.EXT-DET DET man-DET DET-NOM Wany
 (ii) 'Wany saw the one who helped the man.'
 (iii) *'The man saw the one who helped Wany.'

(ii) is a licit interpretation of (i) because *ti sqáycw-a* 'the man' is the object of the verb. Conversely, (iii) is an illicit interpretation of (i) because *ti sqáycw-a* 'the man' cannot be the subject of the verb.

⁸ Note that names are DPs: they are introduced by a determiner (which can be dropped, as is the case for instance in (7)).

positions - i.e. that IP2 in (11b) is adjoined to the matrix clause.⁹ Condition C would then be inapplicable in (11b) since neither nominal would be c-commanded by the matrix subject. However, the hypothesis that complement clauses in ST' are adjunct clauses is untenable: it incorrectly predicts that complement clauses should pattern like adjunct clauses with respect to wh-extraction. Although the binding facts do not distinguish complement clauses from adjunct clauses, extraction facts do, as shown by the paradigm in (12) from Davis (1993).

- (12) a *_{[CP swat ku áts'xen-acw ti mixalh-a [CP i t'íq-as]]}
 who LINK see-2SUB.CONJ DET bear-DET when come-3SUB.CONJ
 '[who_i did you see the bear [when t₁ arrived]].'
 b _{[CP swat ku tsut s-Wany [CP kw-s [IP2 áts'xen-as s-Bucky}
 who LINK say NOM-W. DET-NOM see-3SUB.CONJ NOM-B.
 '[who_i did Wany say [t₁ saw Bucky]].'

Extraction from an adjunct clause in (12a) triggers a CED effect whereas extraction from a complement in (12b) fails to trigger a CED effect, thus, indicating that the complement clause cannot be analysed as an adjunct clause.¹⁰

3.2 Hypothesis #2: parametrizing Binding domains

To explain the restricted domain of Condition C in ST', Davis (1993) and Matthewson (1993) make two assumptions. First, they reject the PAH and assume that overt

⁹ This line of analysis is plausible since although Baker (1996) rules out dislocation of complement clauses (via the categorial mismatch between a coreferent *pro* - i.e. a DP - and its antecedent CP), he allows dislocation of nominalized clauses, and there is evidence that complement clauses are nominalized in ST. See also footnote 10.

¹⁰ Mark Baker (p.c.) suggests that the island and binding facts could be explained by assuming that:

- (i) wh-movement happens before the dislocation of the CP.
- (ii) the CP does not reconstruct for Principle C at LF.

This line of analysis, however, incorrectly predicts the absence of Condition C effects altogether (across clauses), as Baker himself points out. In section 4, I argue that this is empirically incorrect: violations of Condition C in ST' are exclusively violations of coreference anaphora. BVA never violates Condition C. In other words, (i-ii) incorrectly predicts that 'Who_i does Lisa_j/pro_j know t_i loves Wany?' is licit in ST'.

nominals are base-generated in A-positions. Second, they parametrize Condition C: ST does not obey the standard formulation of Condition C but rather the formulation given in (13) where the Domain D is defined as the minimal clause containing the relevant R-expression.

(13) *St'át'imcets*: An R-expression is free in the Domain D.

The revised version of Condition C in (13) together with the assumption that R-expressions are in A-positions explains why Condition C is clause bound in ST'. I now argue against Davis and Matthewson's (henceforth D&M) analysis.

3.3 Two reasons for not parametrizing Condition C

I first reject D&M's analysis on empirical grounds by showing that whereas coreference anaphora violates Condition C, bound variable anaphora (BVA) never violates Condition C. This asymmetry is not surprising since coreference - unlike BVA - can violate Condition C in English under the appropriate discourse context, as the contrast in (14) illustrates.

- (14) a I know what Ann and Bill have in common.
 She thinks that Bill is terrific and he_i thinks that $Bill_i$ is terrific.
 (Grodzinsky & Reinhart 1993, adapted from Evans 1980)
- b I know what Ann and every linguist at this conference have in common.
 *She thinks that every linguist is terrific and he_i thinks that *every linguist_i* is terrific.

I further reject D&M's analysis on conceptual grounds since it is incompatible with the general approach to anaphora that has emerged from current research on the cross-linguistic distribution of anaphors, an approach which Safir (1995) has very appropriately dubbed 'universalist'.¹¹ The thrust of this research has been to achieve a simplification of binding theory by eliminating the need for parametrized binding domains. Under a universalist approach to anaphora, there are no language particular stipulations concerning the domain size of a given anaphor. Both Condition A effects

¹¹ See Burzio (1991), Everaert (1986, 1991), Pica (1984), Reinhart & Reuland (1991, 1993), Safir (1995) and references therein.

and cross linguistic variation in the domain of Condition A are determined by universal semantic properties of anaphors since, in Safir's own words:

"The central premise of the universalist position is that all anaphora specific statements are universal."

Assuming a universalist approach to anaphora, the null hypothesis is that both Condition C effects and cross linguistic variation in the domain of Condition C are determined by the semantic properties of DPs. I argue that this hypothesis is correct. The restricted domain of Condition C should be derived from a core semantic property of DPs in ST': *DPs in ST' are not presuppositional* (or quantificational, in the sense of Milsark (1977)). If Condition C violations induced by DPs in ST' are derived from their semantic properties, then we expect DPs with similar semantic properties in other languages to also induce Condition C violations. I will show that this is indeed the case by correlating the anaphoric properties of DPs in ST' with those of *focussed* and *deictically* used expressions in English, both of which also induce Condition C violations.

4 Coreference vs. bound variable anaphora in St'át'imcets

Condition C governs two types of anaphoric relations: coreference and BVA. I now show that BVA unlike coreference anaphora never escapes Condition C in ST'.

First, a trace created by wh-movement must satisfy Condition C, as shown in (15). Note that wh-questions in ST' have the syntax of clefts and must involve movement because they obey Island Conditions, as shown by Davis *et al.* (1993). The illicit interpretation of (15a) in (15a') shows that the trace of wh-movement triggers Strong Crossover Effects (SCO). In (15b-b''), we see that long-distance wh-movement also triggers SCO, as the ungrammatical interpretation of (15b) in (15b') demonstrates. Both the interpretations in (15a') and (15b') are illicit because the trace is A-bound, in violation of Condition C. In contrast, (15c) is grammatical under the interpretation in (15c') because the wh-trace is A-free. Note that, in both (15b) and (15c), we know

unambiguously whether the matrix subject or the embedded subject is extracted: subject extraction is signaled by the presence of the "topical object marker" *-tali* on the verb.¹²

- (15) a swat ku áts'x-en-as a' *Who₁ did he₁ see t₁
 who LINK see-TR-ERG a'' Who₁ did he₂ see t₁
- b swat ku zwát-en-as kw-s xwey-s-táli k-Wany
 who LINK know-TR-ERG DET-NOM love-TR-ERG.EXT DET-W
- b' *'Who₁ does pro₁ know t₁ loves Wany.'
- b'' 'Who₁ does pro₂ know t₁ loves Wany.'
- c swat ku zwat-en-táli kw-s xwey-s-ás k-Wany
 who LINK know-TR-ERG.EXT DET-NOM love-TR-3SUB.CONJ. Det-W.
- c' 'Who₁ t₁ knows pro_{1/2} loves Wany.'

Second, a trace created by Quantifier Raising must also satisfy Condition C, as shown in (16). Coindexation between the trace of the QP at LF and the matrix subject *pro* is illicit, as the ungrammaticality of the interpretations in (16a'') and (16b'')¹³ demonstrate.

¹² *-tali* appears on the verb when the ergative (subject) argument is extracted. For some speakers, the presence of *-tali*, is optional: it serves as a disambiguation strategy as in (i) (See Davis 1994, Kinkade 1990, Matthewson 1993 and Roberts 1994 for discussion.)

- (i) swat ku tsew'-en-táli ti sqáycw-a
 who LINK kick-TR-ERG.EXT DET man-DET
 'Who kicked the man?' *'Who did the man kick?'

However, for other speakers, including one of the consultants whose judgments are being reported in (15), the presence of *-tali* is obligatory when the ergative is extracted.

Note also the ungrammaticality of the interpretation in (iii) which shows that wh-traces cannot be A-bound, be it by a pronoun as in (15b-b') or a name as in (ii-iii):

- (ii) swat ku zwát-en-as k-Lisa kw-s xwey-s-táli k-Wany
 who LINK know-TR-ERG DET-Lisa DET-NOM love-TR-ERG.EXT DET-Wany
- (iii) *'Who₁ does Lisa₁ know t₁ loves Wany.'
- (iv) 'Who₁ does Lisa₂ know t₁ loves Wany.'

¹³ Note that the absolutive 3 person plural marker *wit* in (16b) (incorporated onto the matrix verb) is in complementary distribution with a lexical (plural) subject. This means that the QP in (16b) cannot be interpreted as the subject of the matrix clause.

- (16) a cwíl'-en-itas [tákem i sk'wemk'úk'wmi7t-a]
 look for-TR-PL.ERG all PL.DET children-DET]
 a' *'They₁ were looking for all the children₁.'
 a'' 'They₂ were looking for all the children₁.'
 b tsut-Ø-wit kw-s cwíl'-en-as [tákem i sqáyqyecw-a]
 say-ABS-PL DET-NOM look for-TR-ERG all PL.DET men-DET
 b' *'They₁ said she was looking for all the men₁.'
 b'' 'They₁ said she was looking for all the men₂.'

We conclude that A'-traces created by either wh-movement or QR are subject to the classic version of Condition C: they must be A-free.¹⁴

¹⁴ Further support for this generalization is provided by possessor scrambling in ST. Note first that (i) does not tell us anything about the domain of Condition C because (i) is structurally ambiguous between *she kicked Mary's brother* and *Mary kicked her brother*.

- (i) tsuw'en-ás ti qéqtsek-s-a s-Mary
 kick-3SG.ERG DET brother-3SG.POSS-DET NOM-Mary

Matthewson & Davis (1995) argue that 1) the base order is: head noun followed by possessor and, 2) that possessors are internal arguments of N (e.g. [DP the [NP brother of Mary]]). These two assumptions explain why a possessive NP can function syntactically as the main predicate of a sentence *iff* the possessor follows the head noun.

Now, compare (ii) with (iii) which differ only in the position of the possessor. In (ii), the possessor has been scrambled out of the DP to an A'-position (Coordinated possessors are used to ensure that *Mary* in (ii) is not construed as the subject of the clause given the 3-singular ergative marking on the verb). Since coreference between the matrix subject *pro* and *Mary* is impossible, I conclude that possessor scrambling triggers SCO effects.

- (ii) tsew'en-ás [s-Mary múta7 s-John]₁ [DP ti qéqtsek-s-a t₁]
 kick-3SG.ERG NOM-Mary and NOM-John DET brother-3SG.POSS-DET
 *'She₁ kicked Mary₁'s brother and John.' 'She₁ kicked Mary₂'s brother and John.'

In contrast, in (iii), the possessor is in-situ. Since coreference between the matrix subject *pro* and *Mary* is possible, I conclude that in-situ possessors can be A-bound in violation of Condition C.

- (iii) tsew'en-ás [DP ti qéqtsek-s-a s-Mary múta7 s-John]
 kick-3SG.ERG DET brother-3SG.POSS-DET NOM-Mary and NOM-John
 'She₁ kicked the brother of Mary₁ and John.'

In sum, in-situ possessors escape Condition C. In contrast, scrambled possessors cannot escape Condition C. Hukari (1996) reports a parallel contrast in Halkomelem Salish: if a possessor is a

Now, let's turn to noun phrases. There are two classes of noun phrases to consider in turn. NPs introduced by a discontinuous determiner (e.g. *ti...a*) always refer (i.e. always have existential force, as demonstrated by Matthewson 1996). Thus, *tí máwǫ* in (17a) must have wider scope than negation. In contrast, NPs introduced by the linker *ku* never refer (i.e. never have existential force); thus, *kú máw* in (17b) must have narrower scope than negation. Note that *ku*-NPs are syntactically very restricted in their distribution: they are licensed only under the scope of certain operators such as modality, negation, adverbs of quantification or intentional verbs (Matthewson 1996).

- (17) a *cwíl'-en-as tí máw-a* b *cwíl'-en-as kú máw*
 scck-TR-ERG DET cat-DET *seek-TR-ERG LINK cat*
 a' 'There is a cat that he is looking for.' b' 'He is looking for (a) cat.'

In (18), we see that non-referring *ku*-NPs obey the standard version of Condition C: they must be A-free.

- (18) a [_{IP} *tsut* [_{CP} *kw-s* [_{IP} *cwíl'-en-as kú sqáycw kw-s Wany*]
 say DET-NOM look for-TR-ERG LINK man DET-NOM. W.
 *'He₁ said that Wany was looking for a man₁.'
 *'He₁ said that Wany was looking for a man₂.'

In contrast, referential DPs obey D&M's revised version of Condition C in (13): they can be A-bound as shown in (5) repeated as (18b).

- (18) b' [_{IP} *tsut* [_{CP} *kw-s* [_{IP} *áts'x-en-as tí sqáycw-a kw-s Wany*]
 say DET-NOM see-TR-ERG DET man-DET DET-NOM Wany
 'S/he_{1/2} said that Wany₂ saw the man₁.'

In conclusion, *only* referential DPs escape condition C in ST'. This raises three questions. First, why is the domain of Condition C for BVA unrestricted? Second, why is the domain of Condition C for coreference anaphora restricted to the domain D? Finally, why must referential DPs in English obey Condition C (in the general case)

(direct) argument of N, it escapes condition C; if a possessor is an adjunct, it cannot escape condition C.

whereas referential DPs in ST' escape Condition C? In other words, what is the parametric difference between ST' and English?

I will argue that the restricted domain of Condition C in ST' follows from two current proposals in the literature: Reinhart & Reuland's (1993) Binding Theory and Reinhart's (1983) thesis that the grammar only governs BVA. If we adopt these proposals, *the restricted domain of Condition C in ST' is the null hypothesis*. The question then is *not* why can (referential) DPs in ST' violate Condition C but rather why must DPs in English satisfy Condition C.

5 The restricted domain of Condition C for coreference anaphora

Reinhart & Reuland (1993, henceforth R&R) argue that Binding Theory governs only the conditions under which a predicate receives a reflexive interpretation. Their Binding Theory in (19) is simplified for expository reasons.

- (19) a *Condition A*: A reflexive marked predicate is reflexive.
 b *Condition B*: A reflexive predicate is reflexive marked.
- (20) a *núk'w7-an-tsut kw-s Bucky*
 helped-TR-REFL DET-NOM Bucky
 b He_1 helped Bucky₁ → [Bucky (λx (x helped x))]
 c He_1 helped Bucky₂ → * [Bucky (λx (he_1 helped x))]

The predicate in (20a) is morphologically marked as reflexive by the self anaphor *-tsut*. Hence, the reflexive interpretation in (20b) satisfies Condition A whereas the non-reflexive interpretation in (20c) violates Condition A. Conversely, the predicate in (21a) is not morphologically marked as reflexive by the self anaphor *-tsut*. Hence, the reflexive interpretation in (21b) violates Condition B whereas the non-reflexive interpretation in (21c) satisfies it.

- (21) a *núk'w7-an-as kw-s Bucky*
 helped-TR-ERG DET-NOM Bucky
 b ' He_1 helped Bucky₁.' → * [Bucky (λx (x helped x))]
 c ' He_1 helped Bucky₂.' → [Bucky (λx (he_1 helped x))]

In sum, Condition C violations such as (21b) are ruled out as Condition B violations. In contrast, anaphora in (22) is not governed by Binding Theory: the matrix subject and the subordinate arguments are not co-arguments of a predicate. (19) is, thus, inapplicable.

- (22) a [IP tsut [CP kw-s [IP áts'x-en-as ti sqáycw-a kw-s Wany]
 say DET-NOM see-TR-ERG DET man-DET DET-NOM Wany
 b 'S/he_{1/2} said that Wany₂ saw the man₁.'

In conclusion, the restricted domain of Condition C in ST' follows from three properties of the Binding Theory proposed by R&R. First, there is no Condition C. Second, it is not formulated in terms of c-command and, thus, does not distinguish **pro*₁ loves *Sam*₁ from **Sam*₁ loves *pro*₁. Thirdly, its domain is the domain D since it is the domain of the co-arguments of a predicate.

6 The unrestricted domain of Condition C for bound variable anaphora

Grodzinsky & Reinhart (1993), following Reinhart (1983), argue that the Grammar only regulates BVA. I adopt this proposal and thus replace Condition C with a principle that governs exclusively the distribution of variables. Concretely, I propose the following structural conditions on BVA.¹⁵

¹⁵ G&R propose the following principle: An NP is a variable iff: either it is empty and A'-bound or it is A-bound and lacks lexical content. Other cases of NP coindexation are uninterpretable.

For G&R, syntactic coindexation only has one interpretation: that of BVA. Coreference is the assignment of identical values to NPs with *distinct* syntactic indices. In contrast, I assume coindexation can signify covaluation. (I do not see how to rule out intentional coreference in 'Meg₁ thinks Rosa₂ is a genius.' if NPs with distinct indices can corefer.)

(23) *Conditions on BVA:*

An A'-trace must be locally A'-bound

A pronoun must be bound

Local Binding (adapted from Chomsky 1982) α is locally A'-bound by β iff α is A'-bound by β and if δ binds α , then either δ binds β or $\delta = \beta$.

(23) specifies the structural conditions that any pronoun or trace must satisfy in order to be interpreted as a bound variable: a trace must be locally A'-bound in order to be a licit BV whereas a pronoun need only be bound in order to be a licit BV. Note, crucially, that the principle in (23) only regulates BVA. Thus, it only filters out configurations in which a pronoun *inherits* its reference from another NP in the sentence. (23) does not filter out configurations in which two NPs are contextually supplied with the same referent - that is, configurations in which two NPs corefer. Thus, consider the ST sentence in (24a) (illustrated in English for expository reasons). *pro* in (24a) cannot be defined as a variable: it cannot inherit its reference from *Wany* since it is not bound by *Wany*. However, the grammar does not rule out coreference in (24a). Coreference results from the assignment of identical values to NPs with identical syntactic indices (see also Fiengo & May 1994). The notation in (24a) is from Heim (1992): the pointers indicate the reference assignments provided by the utterance context.

(24) a *pro*₁ said that *Wany*₁ loves the man.

\downarrow \downarrow
w *w*

b *Wany*₁ said that I love *pro*₁.c **pro*₁ said that *Wany* loved every child₁.

Whereas anaphora in (24a) can only signify coreference, anaphora in the ST' example in (24b) is ambiguous. It can be analysed as either BVA (*pro* can inherit its reference from *the man* since it is bound by it) or as coreference (the coindexed NPs are assigned identical values). Note finally that coreference is impossible with a QP since a QP does not refer to an individual and, thus, cannot be assigned a unique (constant) value, see also Grodzinsky & Reinhart (henceforth G&R) or Heim (1992). (24c) is thus uninterpretable because *pro* can neither corefer with the QP, nor be interpreted as a variable since it is free.

Let's now see how (23) filters out illicit BVA configurations in ST'. Again, for expository reasons, the syntactic structure of ST' sentences is presented in English. Coindexation in (25a) cannot be interpreted as BVA since the trace is not locally A'-bound. Nor can coindexation be interpreted as coreference since a trace (unlike a pronoun) cannot refer on its own - that is, cannot be contextually supplied with a referent. Hence, (25a) is ruled out under any interpretation of anaphora. In contrast, (25b) is licit: the trace is locally A'-bound and the pronoun can be defined as a variable since it is bound.

- (25) *Wh-movement* (see ST' examples (15)):
 a * $[\text{who}_1 [\text{IP}_1 \text{ does } \text{pro}_1 \text{ know } [\text{IP}_2 \text{ } t_j \text{ loves Wany }]]]$.
 b $[\text{who}_1 [\text{IP}_1 \text{ } t_j \text{ knows } [\text{IP}_2 \text{ } \text{pro}_1 \text{ loves Wany }]]]$.

As for (26a), it will be filtered out at LF as a SCO configuration, if the QP is assigned matrix scope (since the trace of the QP will not be locally A'-bound). If the QP is assigned embedded scope as in (26b), BVA is still illicit because *pro* cannot be defined as a variable since it is not bound by the QP. Further, coreference is impossible between the pronoun and the QP since a QP does not refer to an individual and, thus, cannot be assigned a unique (constant) value.

- (26) *QPs* (see ST' examples (16))
 a * $\text{They}_1 \text{ said Wany is looking for all the boys}_1$.
 b * $[\text{pro}_1 \text{ said } [[\text{all the boys}]_1 [\text{IP Wany is looking for } t_j]]]$.

Finally, (27a) has the LF in (27b) where the indefinite has narrow scope - recall that *ku*-NPs never have wide scope (existential force), cf. (17b). Coindexation in (27b) cannot signify BVA since the pronoun is free. Nor can it signify coreference since a *ku*-NP never refers, and, thus, cannot be contextually supplied with a referent. Hence, (27b) is ruled out. Support for the claim that the option of coreference is excluded in (27a) is provided by the fact that *ku*-NPs do not support cross-sentential anaphora, as illustrated by the ungrammaticality of the discourse sequence in (27c), from Matthewson (1996).

- (27) *ku-NPs* (see ST' examples (18))
- a *He₁ said that Wany was looking for a man₁
- b *[*pro*₁ said [_{TP} Wany [_{VP} ∃_x man (x) [_{VP} looking for x]]]]
- c Ay t'u7 kw-s áz'-en-an [*ku káoh*]_i. *Qv1-7ul *pro*_i t'u7
 NEG just DET-NOM buy-TR-1SG LINK car bad-too just
 'I didn't buy [a car]_i. [It]_i was too bad.'

Anaphora in (27c) becomes licit once we replace *ku* with the determiner *ti...a*. Recall that noun phrases introduced by (discontinuous) determiners always refer, see discussion of (17-18) in section 4.

7 The parametric difference between St'át'imcets and English

Once we assume R&R's Binding Theory together with Reinhart's proposal that the Grammar only governs BVA, the restricted domain of Condition C in ST' is the *null* hypothesis. Condition C effects within the domain of the coarguments of a predicate are filtered out by Condition B. Coreference - outside the domain of Condition B - is free. The *only* question then is why must (referential) DPs in English satisfy Condition C (in the general case).

G&R, following Reinhart (1983), assume that coreference is filtered out by a pragmatic rule.¹⁶ This proposal fails to explain the difference between English and ST': we expect coreference in ST' to be governed by the same pragmatic rule and, thus, anaphora in (28) to be equally bad in English and in ST'. I conclude that coreference is not governed by a pragmatic rule.

- (28) She₁/he₂ said that Wany₁ loves the man₂.

If we adopt a universalist approach to anaphora, this cross linguistic difference in the structural domain of Condition C must be reducible to a cross linguistic difference in the semantics of DPs. I will argue that this is indeed the correct generalization. The

¹⁶ For G&R (cf. Reinhart 1983) the coreferential residue of Condition C is filtered out by the following pragmatic rule of *Intrasentential Coreference*:

- (i) NP A cannot corefer with NP B if replacing A with C, C a variable A-bound by B, yields an undistinguishable interpretation.

relevant cross linguistic difference is the presence vs. absence of quantificational DPs, in the sense of Milsark (1977). Milsark's quantificational noun phrases have also been called presuppositional noun phrases (e.g. Diesing 1992 or Musan 1995). The term here is used to refer to DPs that presuppose a set of individuals *in the context* that satisfy the descriptive content of the noun.

I first provide three arguments to establish that ST' lacks presuppositional determiners.¹⁷ Milsark's quantificational noun phrases include noun phrases introduced by strong determiners (e.g. *every*, *all* or *most*) and definite descriptions. The first argument to support the claim that ST' lacks quantificational DPs is that ST' lacks all determiner-quantifiers. The second argument is that there are no definite descriptions in ST'. The third argument is that DPs in ST' do not have the range of temporal interpretations characteristic of presuppositional DPs. I conclude that the parametric difference between English and ST' can, thus, be restated as follows: DPs in ST' lack quantificational force (since they lack quantificational determiners).

7.1 There are no determiner-quantifiers in Salish (Jelinek 1993, Matthewson 1994)

The first argument is that all Salish languages lack all determiner-quantifiers. This property was first established by Jelinek (1993) for Straits Salish. Matthewson (1994) then argued that no Salish language has a quantifier which is itself a determiner. In particular, while Salish languages allow quantifiers which attach to DPs (e.g. *all DP*), QPs with the structure [$QP Q [NP]$] (e.g. *no man* or *every man*) do not exist in Salish. The structure of QPs in ST' is illustrated in (29).

- (29) [$QP [Q'$ *tákem* [$DP [D'$ *i* [NP *sqáyqeycw*] *a*]]]
 all DET.PL men DET

7.2 There are no 'definite descriptions' in St'át'imcets

Demirdache & Matthewson (1995) argue that if Salish languages lack all determiner-quantifiers such as *every* or *most*, then they lack the definite determiner *the*, that is,

¹⁷ The thesis that there are no presuppositional determiners in ST' is one of the central claims made by Matthewson (1996) where a thorough analysis of the syntax and semantics of determiners and quantifiers in ST' is presented. I thus refer the reader to her work. See also Jelinek (1995), Matthewson (to appear) and Demirdache & Matthewson (1995).

they lack all quantificational determiners in the sense of Milsark (1977), for whom the definite determiner *the* is a universal quantifier (quantifying over a singleton set when it introduces a singular noun phrase). I will provide evidence for this hypothesis by showing that DPs in ST' lack three properties of definites.

7.2.1 Determiners do not encode (in)definiteness (Matthewson 1996)

Matthewson establishes that the Familiarity/Novelty Condition (Heim 1982) does not apply in Salish. This condition states that if a discourse referent is familiar to the discourse, a definite must be used. In contrast, if a discourse referent is novel to the discourse (and unfamiliar to the common ground) an indefinite must be used. Now, consider the ST' discourse sequence in (30) from Matthewson 1996; quoted from van van Eijk & Williams 1981).

- (30) a Húy-lhkan ptakwlh ptákwlh-min lts7a [ti smém'lhats- a]
 will-1SG.SUB tell story tell story-APPL here DET woman- DET
 'I'm going to tell a legend, a legend about a girl₁.'
- b ... Wa7 ku7 ilál láú7 [ti smém'lhats- a]
 PROG QUOT cry DEIC DET woman- DET
 '... The girl₁ was crying there.'

In (30a), the determiner *ti...a* is used to introduce a novel discourse referent. Crucially, the same determiner is used when the DP has the anaphoric reading of a definite, as in (30b). In sum, DPs in ST' do not encode (in)definiteness: the same DP is used felicitously *whether its referent is familiar or novel to the discourse*. Since no DP in ST' must be associated with a discourse referent *that is already in the domain of discourse*, Matthewson concludes that no determiner in ST' triggers the presupposition that the descriptive content of a DP is part of the common ground of the discourse.

7.2.2 No DP is ambiguous between a referential reading and an individual concept reading (Demirdache 1996)

The traditional philosophical literature claims that sentences with definite descriptions are ambiguous depending on whether the definite has an Individual Concept Reading (ICR) or a direct reference reading (cf. Enç 1981 and references therein). On the ICR, *the chief* in (31a) is evaluated at different times and, thus, does not refer to any

particular individual: (31a) can be used to assert that for any time *t* (or that for most times *t*), whoever is president or chief at *t* is powerful at *t*.

- (31) a The chief of the United States is powerful.
 b á7xa7 [ti kel7áqsten-s-a ti United-States-a]
 strong DET chief-3POSS-DET DET US-DET
 'The chief of the United States is powerful.'

In (31b), the DP can be used referentially (it refers to a particular individual that the speaker has in mind, i.e. Clinton) or attributively (it refers to whoever is the present president; the speaker need not know who the president is). Crucially, however, it cannot have an ICR: *the chief* in (31b) cannot be evaluated at different times. The sentence (31b) does not assert that any/most past, present or future chiefs are powerful. The ICR is only possible with a non-referring NP, that is, a *ku*-NP under the scope of the (obligatory) adverb *papt* 'always', as in (32).

- (32) pápt á7xa7 [ku kel7áqsten-s ti United-States-a]
 *(always) strong LINK chief-3POSS DET US-DET
 'A chief of the US is always powerful.'

If we assume, following the traditional philosophical literature, that definite descriptions have either an ICR or a direct reference reading, then no DP in ST' qualifies as a definite description since no DP in ST' is ambiguous between a directly referential reading and an ICR. The DP *ti kel7áqstena* in (31b) never has the quantificational reading of a definite: (31b) cannot be used to assert that any or most (present, past or future) chiefs are powerful. Conversely, the ICR is possible with a *ku*-NP. However, *ku*-NPs are never ambiguous between an ICR and a direct reference reading either since they never refer; recall that they never have existential force, as was illustrated in (17b) and (27c).

7.3 DPs do not have temporally independent interpretations (Demirdache 1996a, 1996b)

The third argument to support the claim that ST' lacks presuppositional DPs is that DPs in ST' do not have the range of temporal interpretations that are characteristic of presuppositional DPs (cf. Musan 1995). In particular, presuppositional DPs allow

temporally independent readings: the temporal interpretation of either a quantified DP or a definite description can be independent of the temporal interpretation of the matrix predicate of its clause. This freedom of interpretation is illustrated in (33). In (33a), the set of chiefs that we are quantifying over is determined by the discourse context: (33a) can be true if all individuals who are chief *now* were powerful at some *past* time or if all individuals who were chief at some past time *t* were powerful at some distinct past time *t'*. Likewise, the temporal interpretation of the presuppositional DPs in (33b-c) is freely fixed by discourse context. Thus, in (33b), the time of being powerful is located in the sixties by the adverbial. The time of being president need not coincide with the past time of being powerful since (33b) can be used to make a statement about the present president (i.e. Clinton). In (33c), from Musan (1995), the people could be homeless *now* but *not* homeless at the time of rally.

- (33) a All the chiefs were powerful.
 b The president was powerful in the sixties.
 c Many of the homeless people were at the rally.

Musan (1995) argues that temporally independent readings are restricted to presuppositional DPs.¹⁸ Thus, the cardinal DPs in (34) are temporally dependent. In (34a), both the time of being a president and the time of being powerful must be located within the sixties. In (34a), the homeless people must be homeless at the time of rally.

- (34) a There was a powerful president in the sixties.
 b There were many homeless people at the rally.

Musan concludes that it is the presupposition of existence triggered by a presuppositional determiner which licenses temporally free readings. If DPs in ST' are not presuppositional, then they should not allow temporally free readings. This is indeed the case as shown in (35). (35a) can only be used to assert that the different *present* chiefs of the US *are* fools, whether the subject is quantified or not. Since the speaker knows that there can only be a *single present* chief of the US in existence at utterance time, (35a) is infelicitous.

¹⁸ More precisely, Musan's (1995) generalisation is that an NP is temporally independent iff it is either presuppositional or the subject of an existence independent predicate.

- (35) a ? *sécsec* (tákem) [*i kel7áqsten-s-a ti US-a*].
 silly (all) PL.DET chief-3POSS-DET DET US-DET
 '(All) The chiefs of the United-States are fools.'
- b *á7xa7 ni kel7áqsten-a c á7xa7 ni kel7áqsten-a*
 strong DET chief-DET strong DET.ABS chief-DET
 'The chief is powerful.' 'The chief was powerful.'

In (35b) the time of being powerful and the time of being a chief are both located in the *present*. Conversely, in (35c), the time of being a chief and the time of being powerful are both located in the *past*. The *single* difference between (35b) and (35c) is the choice of determiner: *ti* vs. *ni*. van Eijk (1997) defines *ni* as the 'absent' determiner: it indicates that the referent of the DP is distant from the speaker (cannot be pointed at). Crucially, the time of being *powerful* in (35c) is itself fixed by the determiner. Why is this the case? Because the time of being a *chief* gets located in the past by the 'absent' determiner when spatial deixis (distance in space relative to the speaker) correlates with temporal deixis (distance in time relative to speech time). The predication time of the NP then fixes the predication time of the *matrix predicate* itself (see Demirdache 1996b, 1997). In sum, the temporal interpretation of a DP in ST' is not independent of the temporal interpretation of the main predicate of its clause.

DPs in ST', thus, lack three correlated properties of definites: 1) no DP triggers the presupposition that its descriptive content is part of the common ground of the discourse, as established by Matthewson; 2) no DP is ambiguous between a direct reference reading and an ICR; and 3) no DP is temporally free.

7.4 Why does St'át'imcets lack a presuppositional determiner?

Determiners in ST' mark distance in space relative to the speaker. They encode a three-way distinction in proximity, as shown in (36). When spatial deixis correlates with temporal deixis, a determiner fixes the temporal reference of the *whole sentence*, as was the case in (35c).

- (36) *ST' Determiners* (adapted from Matthewson 1996; see van Eijk 1997)

	present	absent	remote
singular	<i>ti....a</i>	<i>ni....a</i>	<i>ku....a</i>
plural	<i>i....a</i>	<i>nelh....a</i>	<i>kwelh....a</i>

Note that deixis and anaphora are in complementary distribution: e.g. 'I know her' and 'I know HER' are mutually exclusive and, likewise 'THAT girl' (on its deictic use) and 'That girl' (on its anaphoric use) are mutually exclusive. A determiner, thus, can either *deictically* or *anaphorically* anchor an NP-referent into the domain of discourse. I conclude that the difference between English and ST' resides in how NP-denotations are linked to the domain of discourse. In English, NP-denotations can be *anaphorically* linked to the domain of discourse via the presupposition that a determiner triggers. In ST', NP-denotations are always *deictically* linked to the domain of discourse because determiners encode spatio-temporal deixis.¹⁹ A determiner in ST' anchors the referent of an NP into the domain of discourse by locating it in time and space relative to the speaker. A determiner in ST' cannot anchor the referent of an NP into the domain of discourse by triggering the presupposition that the descriptive content of the NP is part of the common ground because deixis and anaphora are in complementary distribution.

Note that this proposal gives us an intuitive explanation for why NPs introduced by the determiners in (36) *must* have existential force (cf. (17a)). If an entity is located in space and time, then it 'exists'; as Carlson (1977) argues: "... there is a close relationship between an entity having a stage in a world at a time, and existence. ... If we argue about whether or not King Arthur ever existed... If someone comes up with convincing evidence that King Arthur, at such and such a time, ran between London and Bath, we would thereby be convinced that King Arthur existed. This is because running between London and Bath is true of a stage of King Arthur, and if he has a stage in this world at a given time, he existed at that time." (See Demirdache 1996a)

Finally, the fact that DPs escape Condition C in ST' is not surprising if determiners encode spatio-temporal deixis, since deictically used DPs in English can violate Condition C, as the following example from Evans (1980) illustrates. As Evans points out, anaphora in (37) is licit when *this man* is used deictically to refer to Stalin.²⁰

(37) Stalin_i signed this man_j's papers.

¹⁹ See Demirdache (1996b, 1997).

²⁰ See section 9 below on the correlation between demonstration and focus, which both allow a DP to escape disjointness requirements.

7.5 Conclusion: DPs in St'át'imcets do not have quantificational force

To recapitulate, I have established thus far that Condition C violations are restricted to referential DPs in ST'. The null hypothesis is that there are no language particular stipulations regarding the size of binding domains. This cross linguistic difference in the structural domain of Condition C should, thus, be derived from a cross linguistic difference in the semantics of DPs. The relevant semantic difference is the presence vs. absence of quantificational (presuppositional) determiners. We can, thus, restate the parametric difference between English and ST' as follows: DPs in ST', unlike DPs in English, lack quantificational force since they lack quantificational determiners. In section 8, I show how this proposal can explain the restricted domain of Condition C for coreference anaphora in ST'. Syntactic evidence for the claim that DPs in ST' lack quantificational force will be provided in section 8.2 where I argue that this assumption explains the restrictions on the number and the interpretation of DPs in ST', discussed in section 1.

8 The coreferential residue of Condition C

I have argued that the restricted domain of Condition C in ST' supports Reinhart's thesis that the grammar only restricts BVA, but that coreference anaphora is not governed by a pragmatic rule (cf. section 7). If this is the case, then why is anaphora illicit in say (38)? As is well known, however, anaphora in (38) is felicitous, when the appropriate discourse context is supplied, as illustrated in (39).

(38) a He₁ thinks that Bill₁ is stupid. b Bill₁ thinks that Bill₁ is stupid.

(39) I know what Ann and Bill have in common.

She thinks that Bill is stupid and *he/Bill* thinks that *Bill* is stupid.

-

How then do we interpret the grammaticality contrast - since there is one - between (40a) and (40b)?

(40) a Bill₁ thinks that he₁ is stupid. b He₁ thinks that Bill₁ is stupid.

I take this grammaticality contrast to signify that anaphora in (40a) does not yield the same range of interpretations as in (40b). Thus, consider the classic paradigm in (41) adapted from G&R, where the focusing particle *only* serves to tease apart the possible relations between the interpretations of the name and the pronoun in (40). (41a) has two readings which are not truth conditionally equivalent: nobody besides Bill considers *himself* to be stupid or nobody besides Bill considers *Bill* to be stupid. In contrast, (41b) can only mean that nobody besides Bill considers *Bill* to be stupid.

- (41) a Only Bill₁ thinks he₁ is stupid.
 b Only he₁/Bill₁ thinks Bill₁ is stupid.

Thus, whereas (42a) has the interpretations paraphrased in (42b-c), (43a) does not have the same range of interpretations. Attempting to assign to (43a) the construal in (43c) is what I take to be the source of the Condition C effect.

- (42) a Bill₁ thinks that he₁ is stupid. b Bill₁ thinks that Bill₁ is stupid.
 c Bill thinks (him)self is stupid.
 (43) a He₁/Bill₁ thinks Bill₁ is stupid. b Bill₁ thinks that Bill₁ is stupid.
 c *Bill thinks (him)self is stupid.

I conclude that the grammar should *not* rule out any coindexation relation *per se*. It should rule out any *impossible* interpretation of this coindexation. If we make the standard assumption that the two interpretations of (42a) correspond to the traditional distinction between BVA and coreference, we can then filter out the impossible interpretation of coindexation in (43), as a violation of BVA. Concretely, I assume that QR freely adjoins any DP to any legitimate scope position.^{21, 22} Any output of QR is subject to the conditions on BVA. Adjoining *Bill* to the matrix IP yields the LF in (44a). Coindexation in (44a) cannot signify BVA since the trace is not locally A'-bound, cf. the *Conditions on BVA* in (23). Nor can it signify coreference: a trace cannot be contextually supplied with a referent since, unlike a pronoun, it cannot refer

²¹ Including definites, specific indefinites and names (assuming that names are hidden definite descriptions). The claim that QR does not distinguish between referential DPs and QPs is found in Abe (1993), Heim (1982) and Reinhart (1983) among others.

²² In Beghelli & Stowell, QR does not apply uniformly to all QP-types: each QP-type is assigned a canonical scope position at LF. Specific DPs (including definites or names) can be assigned to the highest scope position of the sentence (that is, REFERENCE P).

on its own. The LF in (44a) is, thus, filtered out by the grammar. However, adjoining *Bill* to IP₂ yields a well-formed LF: (44b) is licit since the trace is locally A'-bound. The pronoun, however, is not bound. Hence, anaphora in (44b) can only signify coreference: identical values are assigned to the coindexed NPs. Crucially, the grammar has not filtered out coindexation in (44b): only the BV interpretation of this coindexation.

- (44). a [IP *Bill*₁ [IP *he*₁ thinks [*t*₁ is stupid]
 b *he*₁ thinks [IP₂ *Bill*₁ [IP₂ *t*₁ is stupid]

The simple idea behind the analysis that I have just sketched is that 'He thinks that Bill is stupid' cannot mean that 'Bill thinks that he himself is stupid'. This is the case because the (matrix) pronoun is free and further, if we were to try to force this interpretation by giving *Bill* matrix scope as in (44a), a SCO violation would ensue. Attempting to assign *Bill* matrix scope is the source of the Condition C effect.

Recall, however, that intended coreference in (38) is licit *only* in the appropriate discourse context (e.g. (39)). Tancredi (1995), citing Higginbotham, states that whenever disjointness requirements are overridden, at least one of the two NPs must be focussed.²³ This raises three questions which will be addressed in section 9: When can focus override disjointness requirements? Why can focus override disjointness requirements? Why can Condition C violations in ST' (but not in English) freely occur context initially (out of the blue)? I will correlate the anaphoric properties of DPs in ST' with those of focussed DPs in English. Finally, I will derive the effect of focus from the proposal that focus alters (restricts) quantifier scope.

8.1 Deriving the restricted domain of Condition C in St'át'imcets

We can now derive the restricted domain of Condition C from the core semantic property of DPs in ST'; namely, that DPs in ST' lack quantificational force (since they lack quantificational determiners). Thus, consider (45). Why is anaphora licit in (45a)? Because (45a) will never be ruled out at LF. DPs in ST' cannot undergo QR at LF since they lack quantificational force. Hence no A'-trace is created by QR at LF that could induce a violation of the *Conditions on BVA*. The grammar only filters out a BV interpretation of *pro* in (45a): *pro* is not a BV since it is free. Assignment of identical

²³ cf. Evans (1980), Horvath & Rochemont (1980), Tancredi (1995) and references therein.

values to the co-indexed NPs yields coreference. In contrast, coindexation in (45b) can signify either BVA (since *pro* is bound) or coreference (if the co-indexed NPs are assigned identical values).

- (45) a *pro*₁ said the girl₁ loves cats. b The girl₁ said *pro*₁ loves cats.

In sum, DPs in ST' violate Condition C because DPs in ST' have no quantificational force: determiners in ST' do not *anaphorically* link an NP-denotation to the domain of discourse. I will now provide syntactic evidence for this analysis by showing that it can also explain the restrictions on the interpretation and the number of DPs in a sentence, as discussed in section 1. In particular, I will argue that the ONI is not a restriction on interpreting a single DP as the subject of a sentence. It is a restriction on interpreting a DP as the canonical topic of a sentence.

8.2 DPs in St'át'imcets are not (syntactic) topics²⁴

Recall that a transitive sentence with two third-person arguments and a single DP should be ambiguous, since DPs are not case-marked. Thus, (3a) repeated below should have the two readings in (3b). However, the single DP in (3a) is construed as the absolutive argument (object), not the ergative (subject).

- (3) a áts'x-en-Ø-as ti sqáycw-a b 'She saw the man.'
 see-TR-ABS-ERG DET man-DET *'The man saw her.'

The ONI (as stated in (3c), section 1) is not a surprising restriction: it merely reflects the default topichood of the subject of a sentence and the absence of presuppositional DPs in ST'. Milsark (1977) suggests that (syntactic) topics must be quantified (presuppositional) and Reinhart (1982) argues that they carry existential presuppositions. We can derive the ONI from 2 assumptions: (i) the canonical mapping of the topic of the sentence onto the external subject position (Spec IP) and, (ii) the inability of DPs to QR out of the VP in ST' since they lack quantificational force (cf. Diesing 1992). The ONI is, thus, not a restriction on interpreting a single DP as the

²⁴ The analysis of the ONI and the *Avoid Two DPs* constraint outlined in this section is adapted from Demirdache & Matthewson (1995) (see also Demirdache *et al.* 1994). I refer the reader to Davis (1994) and Roberts (1994) for further discussion of the ONI and to Davis (1994) and Kinkade (1990) for discussion of the distribution of overt nominals.

subject of a sentence. It is a restriction on interpreting a DP as the canonical topic of a sentence.

To derive the ONI, we could alternatively assume that *pro* must be the topic of a sentence because it is obligatorily anaphoric to a previously established discourse referent. Recall, however, that sentences with two DPs are dispreferred. Indeed, they are prohibited in some Salish languages (e.g. Lushootseed, cf. Hess 1973). The hypothesis that *pro* is topic-bound fails to explain this *Avoid Two DPs* constraint. In contrast, the proposal that DPs cannot be syntactic topics because they lack quantificational force can derive this constraint. Sentences with two DPs contain no topic, and, thus, are restricted to marked discourse contexts, e.g. when the whole sentence is in the domain of focus, as is the case with sentences 'elicited' out of the blue.

Note, finally, that the above analysis of DPs in ST' is conceptually the reverse of the PAH. Baker (1993) makes a parallel between the PAH and clitic-left dislocation. In contrast, I have argued that DPs in ST' are neither dislocated nor topics. In fact, the topic of a sentence - that is, the constituent in a sentence whose properties are under discussion - is usually *pro*.

9 Focused DPs and deictically used DPs in English

If all anaphora specific statements are universal, then we expect DPs with semantic properties similar to those of DPs in ST' to also escape Condition C. I will argue that this is indeed the case by correlating the semantic properties of DPs in ST' with those of focussed DPs and deictically used DPs in English, both of which induce Condition C violations.

Prince (1985) defines the topic/background of a sentence as salient shared knowledge ("what the speaker assumes about the hearer's belief") and the focus as "that which is not shared by the speaker and the hearer". Now, recall Matthewson's proposal (section 7.2.1). The descriptive content of a DP in ST' is never presupposed to be part of the common ground of the discourse; it is not part of the information that the speaker assumes the hearer already knows or believes. The *descriptive content* of a DP in ST' is, thus, *part of the main assertion* of a sentence: *the focus*. It is, thus, not surprising that a single DP in a transitive sentence must be interpreted as the object of the verb (cf. the ONI) or that sentences with two overt DPs are rare in ST' (cf. the

Avoid Two DPs constraint), since the VP is the canonical domain of focus.²⁵ Note a further correlation between DPs in ST' and focussed DPs: both encode either novel or familiar discourse entities.

In English, focussed DPs must be accented. In contrast, DPs in ST' cannot be accented (Mark Hewitt p.c.). Why? Because the null vs. overt nominal distinction plays the role of focal stress in English. That is, whereas in English, the destressed vs. stressed distinction serves to identify focus, in ST', it is the null vs. overt argument distinction which serves to identify focus.

Finally, recall that deictically used NPs also escape Condition C, as the example in (37) (repeated below) illustrated. Anaphora in (37) is licit when *this man* is used deictically to refer to Stalin.

(37) Stalin_i signed this man_j's papers. (Evans 1980)

Higginbotham (1996) correlates the effect of focus with that of demonstration in overriding disjointness requirements. He argues that disjointness requirements can be overridden when referential identity (anaphora) between two expressions is asserted (thus, identity statements such as *Max/He is Colonel Weisskopf* typically violate Condition C) but enforced when anaphora is presupposed. Anaphora (identity) between two expressions, one of which is either focussed or deictically used, is not presupposed but asserted and, hence, not subject to Binding Theory because Binding Theory only governs presupposed anaphora. The semantic properties of DPs in ST', which escape Condition C, provide empirical support for Higginbotham's correlation between the role of demonstration and that of focus in overriding disjointness requirements since DPs in ST' are deictically anchored into the domain of discourse (as argued in section 7.4.) and the descriptive content of a DP in ST' is part of the focus (the main assertion) of a sentence (as I have just argued). Further, the semantic properties of DPs in ST' support Higginbotham's distinction between presupposing vs. asserting anaphora: if the descriptive content of a DP is not presupposed, but asserted, to be part of the common ground of the discourse (as argued by Matthewson (1996); cf. section 7.2.1.), then anaphora with a DP in ST' is asserted not presupposed.

²⁵ What is surprising, however, is that the ONI is suspended in transitive sentences with a 1st or 2nd person argument; see Davis (1994) for discussion.

I now turn to the question of why focus overrides Condition C in English.²⁶

9.1 Focus and Condition C violations in English

The effect of focus is illustrated in (46), adapted from Evans (1980): intended coreference between the pronoun and the capitalized NP (indicating focus) is licit.

- (46) Who does Oscar love?
 I know *he* loves OSCAR, but does he love anyone else?

Note, however, that focus does not rescue a violation of BVA, as the ungrammaticality of (47b) (provided by Michael Rochemont p.c.) illustrates.²⁷

- (47) a A: I heard that the girl that John loves betrayed Sally?
 B: You heard wrong. The girl he₁ loves betrayed JOHN₁.
 b A: I heard that the girl that each man loves betrayed Sally?
 B: You heard wrong. *The girl he₁ loves betrayed EVERYONE₁.

Horvath & Rochemont (1986) propose that Condition C is overridden when the discourse provides an antecedent for a pronoun that has no sentence internal antecedent. Thus, (46) is not a violation of Condition C: Condition C governs sentence internal anaphora and anaphora in (46) is *not* established via sentence internal coindexing. Tancredi (1994, 1995) derives the interaction of focus with anaphora from a constraint on deaccented expressions: an expression can be deaccented only when the preceding discourse provides an identical occurrence of this expression. Thus, coreference in (46) is licit because the context provides the deaccented pronoun *he* with an antecedent (*John*).

The role that focus plays in overriding disjointness requirements is not reducible, however, to the occurrence of a *prior antecedent* in the discourse. Focus does not override Condition C when the immediate context supplies an appropriate antecedent for an NP; but rather when it provides the appropriate presupposition that the focussed

²⁶ Focus also overrides Condition B effects. If the proposal outlined in the next section is on the right track, it should extend to any exemption of a disjointness requirement induced by focus. I restrict the discussion here to Condition C for reasons of space.

²⁷ See also the contrast in (14), section 3.3.

constituent stands in relation to. Thus, consider the following paradigms where *A*'s question provides a suitable prior antecedent for either the pronoun or *Oscar* in *B*'s answer. We see that occurrence of a prior antecedent does not license the full range of possible Condition C violations. The only licit anaphoric patterns in (48) are those with focus either on the *subject* or on both the subject and the object. Conversely, the only licit anaphoric patterns in (49) are those with focus either on the *object* or on both the subject and the object.

- | | | | |
|------|---|------|---|
| (48) | A: Who loves Oscar ₁ ? | (49) | A: Who does Oscar ₁ love? |
| | B's answer: | | B's answer: |
| a | HE ₁ loves Oscar ₁ . | | HE ₁ loves Oscar ₁ . |
| b | OSCAR ₁ loves Oscar ₁ . | | * OSCAR ₁ loves Oscar ₁ . |
| c | * He ₁ loves OSCAR ₁ . | | He ₁ loves OSCAR ₁ . |
| d | * Oscar ₁ loves OSCAR ₁ . | | Oscar ₁ loves OSCAR ₁ . |
| e | OSCAR ₁ loves OSCAR ₁ . | | OSCAR ₁ loves OSCAR ₁ . |

I conclude that the interaction of focus with anaphora raises two distinct questions: *why* and *when* can focus override Condition C? Focus overrides Condition C *when* the immediate context provides the appropriate presupposition that the focussed constituent stands in relation to. In (48), a proposition of the form 'x loves Oscar' is under discussion (supplied by the context). The focus instantiates the variable in this open proposition. The only licit anaphoric patterns, thus, are those where at least the subject is focussed. Conversely, in (49), the proposition 'Oscar loves x' is under discussion. Thus, the only licit anaphoric patterns are those where at least the object is focussed. In section 9.2, I address the question of why focus can override Condition C.

Recall however that no presupposition needs to be supplied by the immediate context in order to license a Condition C violation in ST', as is the case in English; that is, condition C violations occur context initially (out of the blue) in ST'. This is the case because a DP in ST' does *not* itself constitute *the focus* (the main assertion or the informative part) of a sentence. It is *included* within the focus of a sentence. Note finally that deictically used DPs in English can also violate Condition C context initially, cf. Evans' example in (37), section 9.

9.2 Why does focus override condition C?

Consider (50a). Note that although anaphora in (50a) is licit, it cannot be construed as BVA. The speaker who utters (50a) is not attributing to Oscar, the property of loving *himself*. She attributes to Oscar, the property of loving Oscar. Thus, BVA in *both* (50a) and (50b) must be ruled out.

- (50) a He₁ loves OSCAR₁. b *He₁ loves Oscar₁.

If we assume that QR applies to all DPs, BVA in both (50a) and (50b) will be ruled out at LF as a SCO violation. QR applies to either (50a) or (50b), adjoining *Oscar* to the IP node dominating it, yielding the LF in (51a). (51a) is filtered out by the BVA Conditions in (23): the trace is not a licit variable since it is not locally A'-bound. Thus, neither (50a) nor (50b) can be assigned the BV interpretation in (51b).

- (51) a *[IP Oscar₁ [IP he₁ loves t_j] → b *Oscar (λ x (x loves x))

The conditions in (23) and the assumption that QR applies indiscriminately to QPs and DPs correctly rule out anaphora in (50). Why then is intended coreference possible in (50a)? The answer must be that focus affects quantifier scope, as argued by Beghelli & Stowell (1995):

- (52) Focus constructions have distinctive LF-representations, which distort the scope construals of focussed QPs, giving rise to relative scope relations that are otherwise unavailable. Focus has this effect because focussed constituents are scoped out and behave as if they constitute the nuclear scope domain, with the remnant of the clause functioning as a restricting clause (as in Herburger 1993).²⁸

The effect of focus on quantifier scope is illustrated in (53) from Erteschik-Shir (1993). Both (53b) where the QP is in object position (i.e. inside the canonical domain

²⁸ See also Partee (1991) where topic-focus structure is mapped onto tripartite quantificational structures: topic (or background) corresponds to restrictive clause; focus or the combination of topic with focus corresponds to nuclear scope.

supplied with the same referent. The restricted domain of Condition C in ST' for coreference anaphora is, in fact, the null hypothesis.

The grammar does not rule out any coindexation relation *per se*, but rather filters out all the impossible interpretations of this coindexation relation. These interpretations can be filtered out as violations of BVA, if we assume that QR applies indiscriminately to DPs and QPs. The same generalization explains why focussed DPs in English and referential DPs in ST' escape Condition C. In particular, focus overrides disjointness requirements because focus alters (restricts) quantifier scope; that is, focussed DPs in English do not escape from the VP at LF. Likewise, referential DPs in ST' do not escape from the VP at LF: they lack the quantificational force to QR out of the VP because determiners in ST' are not presuppositional, that is, determiners in ST' do not *anaphorically* anchor the referent of an NP into the domain of discourse by triggering the presupposition that the descriptive content of the NP is part of the common ground. The syntax of a given DP at LF, thus, universally, determines the anaphoric relations it can enter into.

References

- Abe, Jun. 1993. *Binding conditions and scrambling without A/A' distinctions*. Ph. D. Dissertation. University of Connecticut.
- Baker, Mark. 1993. *The Polysynthesis Parameter*. New York: Oxford University Press.
- Beghelli, Filippo & Tim Stowell. 1995. The direction of quantifier movement. Ms. University of California, Los Angeles.
- Burzio, Luigi. 1991. The morphological basis of anaphora. *Journal of Linguistics* 27. 81-105.
- Carlson, Greg. 1977. *Reference to kinds in English*. Ph. D. Dissertation. University of Massachusetts at Amherst.
- Chomsky, Noam. 1982. *Some Concepts and Consequences of the Theory of Government and Binding*. Cambridge: The MIT Press.
- Davis, Henry. 1993. A configurational pronominal argument language. *Proceedings of WECOL 1993*. Washington: University of Seattle.
- Davis, Henry. 1994. Tali-ho! *Papers for the 29th International Conference on Salish and Neighboring Languages*. Pablo, Montana. 117-144.
- Davis, Henry. 1997. Remarks on Word Order and Scrambling in St'át'imcets. Fifth Annual Salish Morphosyntax Workshop. University of Victoria, British Columbia.
- Davis, Henry, Dwight Gardiner & Lisa Matthewson 1993. A comparative look at wh-questions in Northern Interior Salish. *Papers for the 28th International Conference on Salish and Neighboring Languages*. Washington: University of Seattle. 79-95.
- Demirdache, Hamida. 1995. La Condition C du liage et l'hypothèse des langues à arguments pronominaux. Paper presented at Langue et Grammaire 2. University of Paris VIII.
- Demirdache, Hamida. 1996a. The temporal reference of noun phrases in St'át'imcets (Lillooet Salish). Paper presented at the LSA Annual Meeting. San Diego.
- Demirdache, Hamida. 1996b. The chief of the United States sentences in St'át'imcets (Lillooet Salish). *Papers for the 31st International Conference on Salish and Neighboring Languages*. University of British Columbia, Vancouver.
- Demirdache, Hamida. 1997. On the Temporal Location of Predication Times: the Role of Determiners in St'át'imcets (Lillooet Salish). *Proceedings of WCCFL XVI*. University of Washington.
- Demirdache, Hamida, Dwight Gardiner, Peter Jacobs & Lisa Matthewson. 1994. The Case for D-Quantification in Salish: All in St'át'imcets, Squamish and Secwepemets. *Papers for the 29th International Conference on Salish and Neighboring Languages*. Pablo, Montana. 117-144.
- Demirdache, Hamida & Lisa Matthewson. 1995. Quantifier-Raising and Focus-Topic Structure in St'át'imcets Salish. Paper presented at the LSA Annual Meeting. New Orleans, Louisiana.
- Diesing, Molly. 1992. *Indefinites*. Cambridge: The MIT Press.
- van Eijk, Jan & Lorna Williams. 1981. *Cuystwl Malh Ucwalmfcwts: Lillooet Legends and Stories*. Mount Currie, B.C.: Ts'zil Publishing House
- van Eijk, Jan. 1997. *The Lillooet Language: Phonology, Morphology, Syntax*. Vancouver: University of British Columbia Press [University of Amsterdam Dissertation 1985].

- Enç, Murvet. 1981. *Tense without scope: an analysis of nouns as indexicals*. Ph. D. Dissertation, University of Wisconsin, Madison.
- Erteschik-Shir, Naomi. 1993. *The Dynamics of Focus Structure*. Ms. Ben Gurion University of the Negev.
- Evans, Gareth. 1980. Pronouns. *Linguistic Inquiry* 11. 337-362.
- Everaert, Martin. 1986. *The Syntax of reflexivization*. Dordrecht: Foris.
- Everaert, Martin. 1991. Contextual determination of the anaphor/pronominal distinction. In Jan Koster & Eric Reuland (eds). *Long-Distance Anaphora*. Cambridge: Cambridge University Press. 77-118.
- Fiengo, Robert & Robert May. 1994. *Indices and Identity*. Cambridge: The MIT Press.
- Gerds, Donna. 1988. *Object and Absolutive in Halkomelem Salish*. New York: Garland.
- Grodzinsky Yosef & Tanya Reinhart 1993. The innateness of binding and coreference. *Linguistic Inquiry* 24. 69-101.
- Heim, Irene. 1982. *The semantics of indefinite and definite noun phrases*. Ph. D. Dissertation, University of Massachusetts at Amherst.
- Heim, Irene. 1991. Anaphora and semantic interpretation: a reinterpretation of Reinhart's approach. Ms. Cambridge: MIT.
- Herburger, Elena. 1993. Focus and the LF of NP quantification. *Proceedings of the 1993 Salt Conference*. University of California, Irvine.
- Hess, Thom. 1973. Agent in a Coast Salish language. *International Journal of American Linguistics* 39. 89-94.
- Higginbotham, James. 1996. On the domain of Binding Theory. Paper presented at the Workshop on Atomism and Binding. Holland Institute of Generative Linguistics, Leiden.
- Horvath, Julia & Michael Rochemont. 1986. Pronouns in discourse and sentence grammar. *Linguistic Inquiry* 17. 759-766.
- Hukari, Tom. 1996. Anaphora in Hul'qumi'num'. Paper presented at the 4th Annual Victoria Salish Morphosyntax Workshop. University of Victoria. British Columbia.
- Jelinek, Eloise. 1984. Empty categories, case and configurationality. *Natural Language and Linguistic Theory* 2. 39-76.
- Jelinek, Eloise. 1993. Languages without determiner quantification. *Proceedings of the BLS*. University of California at Berkeley.
- Jelinek, Eloise. 1995. Quantification in Straits Salish. In Emmon Bach, Eloise Jelinek, Angelika Kratzer, & Barbara Patee (eds). *Quantification in Natural Languages*. Dordrecht: Kluwer, 487-540.
- Kinkade, M. Dale. 1990. Sorting out third persons in Salishan discourse. *International Journal of American Linguistics* 56. 341-360.
- Matthewson, Lisa. 1993. Binding and configurationality in St'át'imcets. Ms. University of British Columbia, Vancouver.
- Matthewson, Lisa. 1994. A comparative analysis of quantification in six Salish languages. Ms. University of British Columbia, Vancouver.
- Matthewson, Lisa. 1996. *Determiner systems and quantificational strategies: evidence from Salish*. Ph. D. Dissertation. University of British Columbia, Vancouver.

- Matthewson, Lisa. to appear. Parametric variation in determiner systems: Salish vs. English. In Amaya Mendikoetxea & Myriam Uribe-Echevarria (eds) *Theoretical Issues in the Morphology-Syntax Interface*. Supplements of the International Journal of Basque Linguistics and Philology.
- Matthewson, Lisa & Henry Davis. 1995. The structure of DP in St'át'imcets. *Papers for the 30th International Conference on Salish and Neighboring Languages*. University of Victoria, British Columbia. 54-68
- Milsark, Gary. 1977. Toward an explanation of certain peculiarities in the existential construction in English. *Linguistic Analysis* 3, 1-29.
- Musan, Renate. 1995. *On the temporal interpretation of noun phrases*. Ph. D. Dissertation. MIT, Cambridge.
- Partee, Barbara. 1991. Topic, focus and quantification. *Proceedings of the 1991 Salt Conference*. Cornell University, Ithaca.
- Pica, Pierre. 1984. On the distinction between argumental and non-argumental anaphors. In Wim de Geest & Yvan Putseys (eds) *Sentential Complementation*. Dordrecht: Foris.
- Prince, Ellen. 1985. Fancy syntax and shared 'knowledge' *Journal of Pragmatics* 9, 65-81.
- Reinhart, Tanya. 1981. Pragmatics and linguistics: an analysis of sentence topics. *Philosophica* 27, 53-94.
- Reinhart, Tanya. 1983. *Anaphora and Semantic Interpretation*. Chicago: The University of Chicago Press.
- Reinhart, Tanya. 1993. Non-quantificational LF. In Asa Kasher (ed.), *The Chomskyan Turn*. Oxford: Blackwell.
- Reinhart, Tanya & Eric Reuland. 1991. Anaphors and logophors: an argument structure perspective. In Jan Koster & Eric Reuland (eds) *Long-Distance Anaphora*. Cambridge: Cambridge University Press. 283-321.
- Reinhart, Tanya & Eric Reuland. 1993. Reflexivity. *Linguistic Inquiry* 24, 657-720.
- Roberts, Taylor. 1994. *Topic and subject in St'át'imcets Salish*. MA. dissertation, University of British Columbia, Vancouver.
- Safir, Ken. 1996. Semantic atoms of anaphora. *Natural Language & Linguistic Theory* 14, 545-589.
- Tancredi, Chris. 1994. Eliminating binding theory. Ms. Yokohama National University.
- Tancredi, Chris. 1995. Intricacies of identity. Ms. Yokohama National University.

The Semantic Significance of Syntactic Identity

Robert Fiengo & Robert May

1 Introduction

Pooh, staring at a bowl of his favorite food, says "Honey is delicious." Christopher Robin, in agreement with his favorite bear, then says "You're right. Honey is delicious." Given what Pooh and Christopher Robin have uttered, we are quite naturally inclined to agree that they have said the same thing, that they have each uttered the same sentence, although of course their utterances of that sentence are distinct. This much seems to be just plain common sense.

This dictate of common sense finds itself expressed in many places. To take an example, here is a passage from Strawson's essay "On Referring":

Consider again the sentence, 'The King of France is wise'. It is easy to imagine that this sentence was uttered at various times from, say, the beginning of the seventeenth century onwards, during the reigns of each successive French monarch; and easy to imagine that it was also uttered during the subsequent periods in which France was not a monarchy. Notice that it was natural for me to speak of 'the sentence' or 'this sentence' being uttered at various times during this period; or, in other words, that it would be natural and correct to speak of *one and the same* sentence being uttered on all these various occasions. It is in the sense in which it would be correct to speak of one and the same sentence being uttered on all these various occasions that I want to use the expression 'a sentence'.

The point might be extended. It might be claimed that it is natural to speak of someone's utterance of "Aristotle was a Greek," referring to the philosopher, and someone's utterance of "Aristotle was a Greek" in reference to the shipping magnate, as utterances of one and the same sentence, and the same might be said of utterances of the sentence "He was a Greek." Now from such examples a moral has been drawn,

of which Strawson's essay is the *locus classicus*: if there is only one sentence in the cases discussed, a notion of "utterance-meaning" would appear to follow. Since we have sentences which are themselves semantically indeterminate, their meanings must be completed with respect to their context of utterance, which supplies a completing semantic value: in the cases at hand, appropriate referents.

In fact, this common sense assumption about sentence individuation has been used as a springboard to even broader implications about understanding language, as examples can be found in which not only is the sentence the same, but so is its (determinate) meaning, yet a distinction must still be made. This has been a lesson drawn from Kripke's "Paderewski" puzzle. Max incorrectly believes there are two people, each named "Paderewski." A speaker may then say "Max believes Paderewski is a genius" and "Max doesn't believe Paderewski is a genius" without contradiction, even though the embedded clauses appear to be syntactically and semantically indistinguishable. That is, not only do we appear to have the same sentence, but the semantic values of the constituents, in particular, the references of the two occurrences of "Paderewski," are the same. But then, the reasoning goes, the difference which makes it possible to make the above reports must be a distinction which resides outside of language, the most popular option being to locate the difference in differing ways of *conceiving* of Paderewski, for example, as either a famous pianist, or as a distinguished statesman.¹

But the sort of intuition which seemed so plain above conflicts with another intuition that strikes us as just as plain. It is the intuition that if an expression is repeated, then it is repeated with its meaning unaltered; otherwise, it would not be a repetition. So, consider the discourse in (1):

(1) Max went to the flea market. Max bought some antiques there.

Suppose we ask a logician to give a formalization of (1). His view would certainly be that we have first a sentence of the form $P(a)$, and then a sentence of the form $Q(a)$, and that their conjunction entails $\exists x (P(x) \wedge Q(x))$. That is, the occurrences of "Max" are understood by the logician to corefer, as two occurrences of a constant term. The logician's view leads us to the issue which is our central concern here: How can we tell, *in the general case*, whether we have the same sentence or not, that

¹ Among those who have taken some form of this approach are Salmon (1985), Recanati (1993) and Crimmins (1992), although the particulars of their implementation widely differ. For a critique of those and other approaches to the "mode of presentation" problem, see Schiffer (1990).

it is indeed the case that we have one sentence uttered twice, rather than utterances of two sentences, albeit sentences which are of superficially similar form? For is it so clear — as a matter of *common sense* — that we have the same sentence in the reports of Max's beliefs about Paderewski, or that we don't have different sentences in the case of (1)? Is it really as clear as Strawson, for instance, would have us believe that we have "one of the same sentence, uttered at various times"?

Let us see what the issue is here. The question as we have posed it is one of the criteria for *linguistic form identity*, so that the issue is one which falls squarely within the province of linguistic theory. After all, it is the job of linguistic theory to give definitions of the central notions of linguistic form, foremost among them being the notion of "sentence." Now, it might be argued that we have indeed presupposed a sort of linguistic theory, one which, as a matter of fact, comports with our common sense. It is this: If the words of uttered sentences are pronounced the same, then they are utterances of the same sentence — if they sound (look) the same, they are the same. Who, after all, would doubt that Pooh and Christopher Robin had each uttered the very same words? But is this really the right way to view the question? This theory, whatever its appeal to common sense may be, is surely not one which would impress anyone versed in linguistic theory. And the linguists would be right not to be impressed, for it has been a consistent lesson of linguistic theory that pronunciation is in no way a reliable guide to form identity, and that there is nothing particularly obvious or common sensical about a definition of syntactic identity based solely on pronunciation.

Given that we do not take it as obvious on the face of it that in any of the cases mentioned there are utterances of the very same sentence, our first task then is to present an appropriate concept of form identity. We place this within the context of the broader issue of the characterization of *syntactic identity* within linguistic theory: the issue, in linguistic terms, of characterizing the notion of "syntactic copy" or "reconstruction." We will then turn our attention to a puzzle about identity statements which, by its analysis, will illuminate most clearly our main ideas about the relation of grammatical identity to how language can be used meaningfully in the service of the expression of our beliefs. We thus place our theory within the context of broader semiotic questions as to the nature of linguistic communication. We will conclude with some reflections on the consequences of our approach for "modes of presentation" and the cognitive significance of language.

2 Indexing and syntactic identity

The question which faces us then is: what are the criteria for the individuation of linguistic expressions? In this section we will sketch out an essential part of the characterization of that notion which we developed in detail in our book *Indices and Identity*, focusing on those aspects of the criteria which are relevant to the puzzles of identity. The central notion we will explore are *indices* and *expressions*; we will do so with some care, as it is important to understand our use of these concepts so that they are not confused with other notions.

We define an *expression* as an ordered pair composed of a noun phrase and an index. It is traditional to indicate the index of an expression by appending a numeral to a node, so, for example, we will have expressions such as “[_{NP} Max]₁”. This notation reflects an approach to the derivation of syntactic structures which assumes that the grammar generates a set of what we call *index trees*, ordered graphs whose nodes are occurrences of indices, represented by numerals, and constrained by a set of well-formedness conditions specifying proper arrays of indexical occurrences. Index trees are *realized* relative to a morpho-syntactic interpretation, specifying the categorial and word structure of the index tree, such that coindexed nodes will receive the same interpretation, non-coindexed nodes different interpretations. We call an interpreted index tree a *phrase-marker*. The set of *expressions* of a language is then to be identified with the set of realizations of the constituents of index trees of the language. Put otherwise, an expression is a morpho-syntactic interpretation of an index; the ordered pairing of an NP and an index indicating the specific interpretation of that index. Thus, when we write the expression “[_{NP} Max]₁” we indicate that the interpretation of the index “1” is as a noun phrase with the terminal element “Max”, and there may be any number of occurrences of this expression in a discourse (set of sentences).²

² A central linguistic issue on this conception is the place of Binding Theory. As far as we can see, all approaches to binding theory can be cast in the form of theories which regulate the distribution of expressions, although there is an issue whether it is to be cast as fixing the well-formedness of arrays of indexical occurrences directly over the index trees themselves, or as part of the morpho-syntactic realization of the trees. Most current thinking would place it in the latter role, given that the binding rules are stated in terms of morphological and syntactic predicates. For our current purposes, however, we allow ourselves the assumption that all relevant issues of formalization of binding theory have been resolved, as all cases we will consider will be uncontroversially consistent with all versions of binding theory of which we are aware.

The reason we choose the notation of numerals can perhaps be most easily gleaned from the following example. Suppose one were presenting a formal logic. Among the things which would be specified would be a stock of variables, x , y , z , etc. One would give the variables in this way because it would be perfectly clear in virtue of their *formal shape* when there are many occurrences of the same variable, as opposed to occurrences of different variables. " $\exists x (P(x) \wedge Q(x))$ " is a different formula than " $\exists x (P(x) \wedge Q(y))$ " in that the latter contains a variable free, where the former does not. Now, if one is being careful in giving this logic, it would not be appropriate to use x , y , z , etc. to notate the variables, since this would limit the number of variables available. Rather, one would notate the variables as x_1 , x_2 , x_3 , . . . since this would insure unrestricted resources — no matter how many variables one had used, there would always be further unused variables. Such resources would be available, however, while still being able to distinguish variables on the same grounds as before, since the numerical subscripts — the indices, if you will — will provide a precise characterization of same and different variable in terms of their shape. Thus, numerals provide exactly the properties we want from a system of indexing: to be able to formally characterize occurrences of expressions without any limitations on the resources whereby we make such differentiations.

This illustration also illuminates the second major property of form or "shape" identity we are seeking to capture. This is that in virtue of being identical with respect to shape, the variables will have the same valuation (under an assignment) — each of the variables in " $P(x) \wedge Q(x)$ " have the same value, for any assignment to x . To take another example which perhaps shows this in even greater relief, there are clearly two occurrences of "2" in " $2 + 2 = 4$ ", each of which refers to the same number; it takes no further calculation to determine this. On the other hand, there is only one occurrence of "2" in " $6/3 + 2 = 4$ ", and the fact that "2" and "6/3" refer to the same number is not something which follows simply from having two occurrences of the numeral "2". Thus, in these logical and mathematical examples, coreference follows directly from shape identity; it is our contention that this is also a property of natural languages.

Turning then to natural language, the thesis that we will be exploring is a simple one. It is just this: *formally identical occurrences of expression are coindexed, and formally distinct occurrences of expressions are not coindexed*. In this regard, it will be sufficient for occurrences of expressions to count as different occurrences of expressions if they bear different indices: " $[_{NP} \text{Max}]_1$ ", as it occurs in a syntactic structure, is an occurrence of a different expression from " $[_{NP} \text{Max}]_2$ ". Since indices are, by hypothesis, part of the formal structure of expressions, occurrences of

expressions which bear different indices will constitute different occurrences of expressions, just as variables bearing different indices constitute different variables. On the other hand, occurrences of expressions which are coindexed will constitute occurrences of the same expression, in virtue of being of the same shape. Now, of course, the operant notion of shape identity will be one which is invariant under certain sorts of shape transformations. So, for instance, we would wish to say that there are two occurrences of the same numeral in " $2 + 2 = 4$ " even though they are in different type faces. The trick, of course, is ultimately to get the invariance principles right, and this is a much more complicated problem for natural language than for logic or mathematics. A central case which raises immediate difficulties of analysis are pronouns. We treat pronouns at some length in *Indices and Identity*, where we argue that when taken at an appropriate level of abstraction, coindexed names and pronouns, for instance, can be taken as occurrences of the same expressions in our sense. (This effect is referred to as "vehicle change.") In the cases we will consider here, however, we will be controlling for various possible sorts of linguistic differences so as to be able to focus directly on the role played by indices, as we conceive of them, in the definition of syntactic identity.

Now, returning to our observations regarding shape identity and valuation, we have the immediate consequence that coindexed occurrences of expressions corefer, if they refer at all. In fact, we have at hand a stronger and more important result, which can be simply stated as follows: *For coindexed occurrences of expressions, the grammar determines coreference.* That is, since coindexed expressions are of the same shape, and this shape identity is determined by grammatical rule, it follows directly from the grammar that coindexed expressions corefer, if they refer at all. In contrast, for non-coindexed expressions, we have the inverse result: *For non-coindexed expressions, the grammar does not determine coreference.* That is, since non-coindexed expressions are not, by definition, shape identical, nothing follows from the grammar about their referential relations. Thus, non-coindexing of expressions is compatible with their being either coreferential or non-coreferential. Note that since the grammar is silent regarding coreference of non-coindexed expressions, if they are coreferential, this *will* depend on the reference associated with the expressions. Only because it so happens that the expressions refer to one and the same thing will it follow that they corefer, so that reference is "prior" to coreference in this case. This difference between the two routes to coreference should be borne carefully in mind, as it will play a central role in the analysis we will present below.

We can now see that in (1) above we actually have two possible cases, (2a) and (2b):

- (2) a $[_{NP}Max]_1$ went to the flea market. $[_{NP}Max]_1$ bought some antiques there.
 b $[_{NP}Max]_1$ went to the flea market. $[_{NP}Max]_2$ bought some antiques there.

In (2a), we have two occurrences of one expression, while in (2b), there are single occurrences of two different expressions. It is with respect to (2a) that the intuition reported above is realized, that when an expression is truly repeated, then so too is its meaning. In the terms that we have now introduced, there is coreference in (2a) as determined by the grammar, but this does not obtain in (2b). As we shall see below, the indexical contrast in (2) bears on the use of sentences by speakers and their communicative intentions.

From a formal perspective, we can characterize the essential character of indices, and their relation to interpretation as follows. With respect to a universe of objects U , let D be a family of discourses, such that each $D \in D$ is a triple $\langle S, I, C \rangle$, where S is an (ordered) set of sentences, I the set of indices which show in S , and C a subset of U , specified under an assignment g mapping from I to C . Moreover, we say that for any $D, D' \in D$, D is *discourse-equivalent* to D' iff D and D' differ in at most a one-to-one permutation of the indices I of D onto the indices of D' , S and C remaining constant. With respect to this characterization, there are a number of things to be pointed out. First is that an indexical distribution holds with respect to a discourse, conceived of as a set of sentences. Thus, the relation between coindexed occurrences when they occur in a single sentence is the same as when they occur in different sentences of a discourse, vis-a-vis syntactic identity. Second, the valuation of expressions with respect to a context can be, so to speak, run off the indices. That is, we can specify contextual points as pairings of indices and values, such that coindexed expressions will always "pick out" the same contextual point, necessarily, while non-coindexed expressions will always pick out different points, although the values associated with the points may be the same. Finally, given the definition of discourse equivalence, it follows that discourses which differ only in the numerical "values" of the indices are equivalent. Thus, it matters not just which numerals are employed. What matters is only the pattern of the indices in the discourse, the projected array of same and different.

We are now in a position to clarify and amplify our notion of indexing, primarily by way of contrast. First off, expressions which are coindexed are not to be thought of as "chained" or "linked" or "roped" together. To think of matters this way would be highly misleading, as it would imply that there is some relation which fixes some referential relation between distinct occurrences of expressions. Thus, just think of the absurdity of drawing an arrow between the occurrences of "2" in " $2 + 2 = 4$ "

in order to indicate that they refer to the same number. Rather, this is determined by their very shape, and once it is established that they are of the same shape, no external indication of their referential relation is necessary or appropriate. At this point, we part company with Evans (1980) and those such as Higginbotham (1983, 1985) who follow him in this regard. To reiterate, the fundamental notion in which indices are pressed into service is syntactic identity — what we have called “shape identity.” Any anaphoric relations in which coindexed expressions stand flows from this relation, and not from any external marking of anaphora. Technically speaking, there is no theory of anaphora; rather there is a theory which deals in sameness or difference of expressions and their occurrences.

A second point to emphasize is that when we say that for coindexed expressions the grammar determines coreference, we mean just that. It does not determine any weaker relation, such as “intended coreference.” The point here can be seen from an analogy. Suppose A were to commit a premeditated murder, doing the deed by shooting B with a revolver. By shooting B, A carries out his intention to kill him; but it is immaterial to his intention that the cylinder moved in the revolver, or that the hammer cocked and then struck the bullet, etc. The only relation the revolver has to A’s intention to murder B is that it is the tool whereby he could transform his intentions into actions; but A does not stand in any particular intentional relation to the way the tool functions so as to carry out his general homicidal intentions. One’s intentions to act do not normally distribute down to the workings of the tools by which the intentions are transformed into actions. They simply work however they work, in terms of whatever “rules” govern their functioning. To take an example closer to our topic, suppose you are asked to utter the word “cat,” and that you comply, thereby satisfying your intention to utter this word so as to fulfill the request. Now, to utter this word, it is necessary that there be velar closure; but assuredly it would be absurd to say that you, in uttering this word, must intend velar closure. Of course a speaker can have such intentions; a speaker can intend coreference, for example, if he were to be asked to utter a sentence in which there is coreference, he may utter one in which there are coindexed expressions. But this is no different than someone who utters “cat” when asked to make an utterance in which there is velar closure, or someone who fires a revolver wanting to show how it works.

Turning now to non-coindexing, we stated that in this case the grammar does not determine coreference. We must be careful to distinguish holding this view from holding something quite different, namely that with non-coindexing, the grammar determines non-coreference. This, put in terms of indexing, was the position held by Lasnik (1976), which was roundly criticized by Evans (1980), and there are many

well-known examples which serve to illustrate the point; see Fiengo and May (1994, ch. 1). To take just one, consider the circumstance of the masked ball. A guest enters the ball, and walking around overhears a conversation in which someone is commenting on Oscar's mental health. Later, reporting the conversation, he says: "He believes Oscar is crazy." Now, given the grammatical structure of the sentence uttered it must have the form in (3), in which there is non-coindexing:

(3) He₁ thinks that Oscar₂ is a genius.

At the end of the evening, as with all masked balls, the guests remove their masks, and lo and behold, the person making the remarks about Oscar was none other than Oscar himself, so that in fact the pronoun and the name in the speaker's utterance of (3) corefer. Yet, the speaker's utterance was grammatical, true and felicitous, properties which we would not expect it to have if non-coindexing meant non-coreference. We would expect it to have these properties on our view of things, since this is not what non-coindexing means. As we pointed out, non-coindexing is perfectly compatible with coreference, just not with grammatically determined coreference. Indeed, (3) is just what the speaker might want to utter, since by uttering this sentence he can leave open whether or not the pronoun and the name corefer, an appropriate thing to do, given the circumstances of masked balls.

It is important to understand that indices form part of the syntactic representation of expressions, and that such representations are the only things of which they are a part. It is thus important to distinguish between a name, a unique lexical item, and the various syntactic expressions in which it can occur as a terminal element. It is certainly indisputable that there is one and only one "spelling" or "shape" 'm^ˆa^ˆx'. But there may be many syntactic expressions containing this name (in a given discourse) which differ *only* in their index, as for instance, in a discourse such as (2b) for above, where we have the syntactic expressions "[_{NP}Max]₁" and "[_{NP}Max]₂", each containing the same terminal string, namely "Max." *Qua* lexical item, there is only one *name* "Max"; an index is no part of this unique spelling. Names, therefore, are to be distinguished from their syntactic expressions in terms of their criteria of individuation, and in what follows we will reserve the term *name* for lexical items, to be distinguished from their *expression* in syntactic structures.

Our view that there is a one-many relationship between names and the syntactic expressions containing them as terminal elements, each distinguished just by its index, is to be contrasted with a different view under which the existence of distinct expressions is a reflection of there being distinct lexical items. By this view, there are

in principle as many homophonous names "Max" as there are people who bear that name, each one distinguished by a lexical feature or diacritic. So, on this view, we have the lexical items "Max_i", "Max_{ii}", etc. (A particularly clear statement of this view is found in Larson and Ludlow (1993); but see Fiengo and May (1997a).) The problem with this view is that (4) comes out as false:

(4) There are many people named "Max."

In fact, on this view, there is *nobody* named "Max." Rather, there is someone named "Max_i", someone named "Max_{ii}", and so on. If we then took it that what lies between the quotation marks is one of these, (4) would still be false, because there is only one person named that. In contrast, on our view, (4) is true. Any number of people may be named "Max"; any number of people may bear this one name as their given name.

Now there is an important implication of our point of view which must be pointed out here. If names in our sense are lexical items, then names *do not* refer. While lexical items have various linguistic properties through which they are individuated, and which determine in part how they may be syntactically expressed, reference is not among these properties. Rather, what refer, or more properly, what speakers use to refer, are expressions containing names; each expression containing a name can be used to refer to an object. The vehicles of reference are indexed noun phrases as they occur in syntactic representation — i.e. sentences — as these are what speakers utter. Speakers, to be sure, believe names to have particular objects as their values, but they can only talk about those values through the utterance of syntactic expressions which can be used to refer to those values. The central question we thus arrive at is how can a speaker syntactically express the names in his lexicon, given the beliefs he has regarding to whom expressions of that name can refer?

The answer we give to this is the following: In a given discourse, there may be as many distinct expressions containing a name as the speaker believes there are values bearing that name. Hence, for a given name, the number of distinct indices it may bear when syntactically expressed (as an NP) in a speaker's utterances (in a given discourse) is equal to the number of distinct values the speaker believes expressions containing that name to have. Thus, while in principle the grammar provides the resources for an indefinitely large number of distinct expressions containing any particular name, this is limited with respect to any particular speaker by his beliefs about the number of individuals who bear that name. There are two important consequences of this relation of names, expressions and speaker's beliefs

to be observed. The first is that non-coindexing will now normally implicate non-coreference. If a speaker believes that there are two people, each named "Max," then he will express this by non-coindexed expressions; his utterances will reflect his beliefs that there are two different people. He may or may not be right about this, but he will have spoken in accordance with what he takes to be the case. The second is that the indices in the utterance of a sentence are normally "speaker's indices." That is, they reflect the beliefs of the speaker about the values associated with a name. If a speaker uses two distinct expressions of a name — i.e. expressions which differ just in not being coindexed — this reflects his belief that there are two distinct objects bearing that name. The association of indices with the speaker, while the norm, is not, however, without exception, as we shall see forthwith.

By way of concluding this section, let us sketch out our view of communicative interaction, as it is this which will play a central role in what follows. Speakers, in using their language, utilize the resources it makes available in order to express what they wish to say. Normally, speakers use those sentences which they believe best express what they want to say, and insofar as their utterances are successful, they will have fulfilled their communicative intentions via their linguistic acts. The grammar which a speaker internalizes defines the resources at the speaker's disposal, the sentences he can use. Central to the characterization of those resources is a definition of syntactic identity, and from this definition flows a notion of expression occurrence, which allows for the carrying on of the reference of that expression. Indices are central to this definition — those expression occurrences which are coindexed are syntactically identical, those which are not-coindexed are not identical in the requisite sense. Now, a speaker uses his language in a manner consistent with his beliefs, in particular with respect to his beliefs about how many values are associated with names, understood as a type of lexical item, and this will be reflected by the array of indices in the expressions in the sentences (of a discourse) the speaker uses. Thus, when a speaker uses a sentence containing an indexed NP, it normally implies that he believes that the expression refers to someone; when he uses two different expressions, that there are two, and so on. Speakers use distinct expressions of a given name because they believe they are referring to distinct objects, and they will use (in a given discourse) such distinct expressions up to a limit of how many distinct objects they believe bear that name. Now a speaker may be wrong in his beliefs about how many values there are for a name, for instance he may believe there are two people named "Max" when there is only one. But this does not lead to any inconsistency; the indexically distinct expressions he uses reflect his beliefs, but this non-coindexing does not entail non-coreference. All that could be concluded is that

since the speaker is speaking in a way which accords with his beliefs, he is not aware that he is mistaken, since if he were, he would not make utterances with the indexing that he does.

A hearer, assuming that the speaker is speaking with all due linguistic virtues, will take all of this to be so: that is, he will take the speaker to be speaking in a way that reflects the speaker's beliefs, and insofar as he properly understands what the speaker says, he will come to represent the sentences the speaker says as the speaker does. That is, the representations of the speaker and hearer will formally match, so that with respect to the representation of the production and the representation of the perception, expressions will be coindexed, and hence coreferential. The hearer, however, may misperceive the speaker, even though the conversation has been conducted with all due linguistic virtue. The bounds of this misperception, for present purposes, is very limited, however — instead of there being coindexing between the expressions in the speaker's and hearer's representations, there is some pair of expressions which are not coindexed. Such misperception may occur for various reasons. For instance, it may be because the participants think, unbeknownst to each other, that different people are being talked about, or one may think that one person is being talked about consistently throughout a conversation, while the other thinks there are two (or more). In such cases, the speaker and hearer will be at some level at cross-purposes, since the hearer did not properly understand the speaker, and confusion may result. To take an example, suppose that Max and Sally attend recitals together, and are fans of a particular pianist. Suppose further that a pianist, as far as they know a different one, rents an apartment in their building, and that they find the music emanating from his flat quite pleasing. Now, Max says to Sally: "He is a fine pianist", referring through the use of the pronoun to the pianist they see in concert. Sally, however, thinks that he is referring to the pianist in their building, plausibly enough, since he made the utterance while passing by his door. What Max said, and wanted Sally to understand, was the sentence *He₁ is a fine pianist*. What Sally heard, however, was the sentence *He₂ is a fine pianist*. Their conversation was at cross purposes, since Sally has not understand what Max said; she took him to have said something which he did not. Notice that it is at cross-purposes regardless of whether the pianist in the recital hall and the one in the apartment are one and the same or not: regardless of whether there is, in fact, coreference. Either circumstance is consistent with what is said and understood, since coindexing is no bar to

coreference, even if it implicates, in a given context, non-coreference, and hence, as in the case above, not comprehending what is said.³

3 A puzzle about identity

We now have in place a conception of the role of indices. In this section we apply this conception to a novel puzzle about identity statements, a problem of central concern since Frege's discussion in the opening paragraphs of "On Sense and Reference." This puzzle has the character that it appears at first glance to hold constant both the syntactic and semantic properties of the expressions involved. But, we will argue, at least as far as the syntactic properties are concerned, this constancy can be seen to be illusory.

We begin with the following scenario. Max is in an unfortunate state. He believes, wrongly, that there are two people, a famous pianist and a great statesman, each

³ Perry (1988), remarking about cases like that we have just described, distinguishes between "internal" versus "external" coreference relations — while the speaker and hearer think they are talking about the same thing, they in fact are not. But, for Perry, "When we recognize the internal coreference relations in discourse, we are often not recognizing structural relations between linguistic entities, but internal coreference relations in the beliefs and intentions of the speaker." Perry reaches this conclusion, since, "internal coreference relations will often be clear though greatly underdetermined by the structure of the language used, meaning here by "structure" the shape of the actual signal that can in principle be perceived independently of recognition of the speaker's intentions." This conclusion does not seem to us warranted. The issue here is the relationship between the representation upon which a speaker's production is based and the representation which is the percept of the hearer. There is certainly an underdetermination of linguistic percept by utterances, but this underdetermination itself is highly restricted, we are arguing, to just two options, in essence, to coindexing or non-coindexing, and if the percept representation does not match the production representation, the hearer will have misperceived the speaker. What are not underdetermined, however, given what the speaker has uttered, and the hearer has understood, are the "internal coreference" relations. Contrary to Perry, there seems to us no reason to think that this is a result of anything other than a relation between linguistic structures, regardless of whether they are connected to productions or perceptions. Clearly speakers have just as much cognitive access to the representations of what they perceive as to the representations of what they utter, nor is access to one sort of representation isolated from the other. Indexical relations "across a discourse" hold just with respect to those representations that the participants each have. While there is an issue about the proper analysis of such linguistic representations, it is quite a different issue as to the *causes* for someone having such representations. It is with respect to the latter that one's beliefs and intentions play a role, as a person's representations will be those which reflect what he intended to say, and what he believes has been said.

named "Paderewski." Max's problem, of course, is not due to any lack of logical acumen; he is merely uninformed about the facts. A benevolent and knowledgeable speaker, wishing to inform Max of his mistake, utters (5) to him:

(5) But Max, Paderewski is Paderewski.

Max takes the point and changes his beliefs, and is thereby relieved of his ignorance, now holding, as do the rest of us, that there is only one person named "Paderewski," who is both a pianist and a politician.⁴

The puzzle: For all appearances, the speaker's utterance of "Paderewski is Paderewski" looks to contain two occurrences of the form "Paderewski," and hence to be of a sentence of the form $\lceil a = a \rceil$. But, the speaker's utterance can be informative, and can be taken as such by Max; so it must be of a sentence of the form $\lceil a = b \rceil$. How can this sentence be of this form, and hence be used informatively? This is the puzzle.

The answer to the first part of the question is straightforward: The occurrences of "Paderewski" bear distinct indices, and hence are occurrences of distinct expressions, so it has the structure in (6):

(6) Paderewski_i is Paderewski_j.

In (6), there are just as much two syntactically distinct expressions as there are in "Cicero is Tully", or for that matter in the (false) "Aristotle is Aristotle", where the first refers to the ancient philosopher, and the latter to the shipping magnate. Here too the occurrences would be indexically distinguished. As far as the form of the sentence uttered is concerned, it is clear that it is of the requisite form so as to be non-trivial.

The second part of the question, how sentence (6) can be used informatively by the speaker, is more difficult to answer, however. Recall that the speaker is fully apprized of the facts about Paderewski, and hence that there is only such person. This speaker would never assert (6) as such, since it implicates something which he does not hold, namely that there are two people, each named "Paderewski." Rather, he

⁴ This scenario is familiar as that found in Kripke (1979), in his discussion about belief. The analysis we present of identity statements carries over in large measure to the belief cases; see the discussion in Fiengo and May (1997b).

would only assert the triviality in (7); since he holds there is only one person, he would express the name "Paderewski" with only one index:

(7) Paderewski₁ is Paderewski₁.

On the other hand, a speaker such as the benighted Max also would not assert (6), since as far as he is concerned, (6) is false. Rather, what he holds is the negation of (6), "Paderewski isn't Paderewski", which can be true only if each "Paderewski"-expression denotes a different person, that is, if it is of the form (8):

(8) Paderewski₁ isn't Paderewski₂.

But as we have seen, (6) *can* be used informatively; it can be used in this manner by a speaker who would assert just (7), to Max, who would assert just (8). It would seem that we face something of a paradox.

The point to see here is that someone saying "Paderewski is Paderewski" to Max can be informative just because Max holds that "Paderewski isn't Paderewski", viz. (8), is true. What a speaker of (6) does by his utterance is to deny what Max holds to be true by stating its negation. He can do this, we can say, by taking Max's very sentence and returning it to him — with its indices intact — negated. By doing this the speaker says to Max that his beliefs about the association of values with the name "Paderewski" are incorrect, and if Max takes the point, he will revise his beliefs accordingly. Thus, the speaker of (6) will have been able to make an informative utterance just because he has not uttered his own sentence, so to speak, but rather Max's sentence modified. The speaker has not asserted (6), and the indices in his utterance of that sentence are not his, but rather Max's. If they were to be those of the speaker, he would have uttered a tautology — to wit (7) — as he would express the name "Paderewski" with only one index.

The communicative interaction which is going on here is thus as follows. What the speaker holds to be true is "Paderewski₁ is Paderewski₁", of the form $\lceil a = a \rceil$; what Max holds to be true is "Paderewski₁ isn't Paderewski₂", of the form $\lceil a \neq b \rceil$. What the speaker then says to Max is: "Paderewski₁ is Paderewski₂", that is, (6), a sentence of the form: $\lceil a = b \rceil$, thereby uttering the negation of what Max holds. The speaker, in uttering (6), denies what Max holds by stating its negation, with its indices intact; he has uttered Max's sentence modified, not his own.

Notice that the expressions used by the speaker in his utterance are not, in a sense, his own; the indices can not be the indices of the speaker, as they do not

reflect his beliefs, nor should they be, if the speaker seeks to speak in terms which the hearer will understand. Rather, the expressions are the expressions of the agent, of Max; as we have put it, the speaker has uttered Max's sentence negated. The indices, therefore, are the "agent's indices"; they are the indices which reflect what Max, not the speaker, believes. Thus, the speaker's utterances are not based on what he believes about the values associated with the name "Paderewski," but rather on his beliefs about Max's beliefs about the values associated with this name. The speaker's utterance is informative not in virtue of being uttered based on his beliefs, but rather because it is uttered on the basis of his beliefs about the hearer's beliefs. When one speaks in the former way, then we have the use of "speaker's indices"; when one speaks in the latter way, then we have the use of "agent's indices."

This difference between speaker's and agent's indices is important because it is the basis of a fundamental difference between the sense in which we can speak of "Paderewski is Paderewski" as being informative as opposed to, say, "Cicero is Tully". An utterance of "Paderewski is Paderewski" in the circumstances described above is used informatively by the speaker to relieve ignorance, and for this utterance to be able to do so it must be of the form $\lceil a = b \rceil$; if it were not of this form, but rather of the form $\lceil a = a \rceil$, then it could not be used informatively as described. But, while it can be so used, no one could *assert* this sentence when of this form on the basis of what he believes about Paderewski; i.e. no one could use this sentence with speaker's indices. As noted, the speaker could not, because he believes there is only one such person, and the hearer could not, as he believes there are two. On the other hand, a speaker could perfectly well assert "Cicero is Tully" on the basis of what he believes about the association of names with values — that is, with speaker's indices — and this is regardless of whether it is used to relieve the ignorance of his interlocutors. This difference shows that we must distinguish two notions of "informativeness." On the one hand, there is a semantic notion which accrues to "Cicero is Tully," which, given its linguistic nature, must be of the form $\lceil a = b \rceil$, but not to "Paderewski is Paderewski", even when it too is of this form. On the other hand, there is an epistemological notion, which accrues to "Paderewski is Paderewski," and insofar as this sentence is used informatively in this sense, it will be of the form $\lceil a = b \rceil$. But while "Cicero is Tully" may also be informative in this sense, it may (but need not be) uttered so as to relieve ignorance, "Paderewski is Paderewski" may never be informative in the semantic sense, as it cannot be directly asserted by a speaker.

While there is much more to say about this, we will conclude our remarks here with just one further observation. Suppose that in fact there are two people, each

named "Paderewski," but that the beliefs of the speaker and hearer are as above, so that now the former is wrong, but the latter is right. The speaker may still utter (6), but its effect will now no longer be to relieve ignorance; rather, acceptance of (6) by the speaker will now just alter his belief to the same incorrect belief as the speaker. Note that the speaker may have uttered (6) perfectly well aware that he was wrong, in which case his motivation would have been to deceive the hearer; but his motivations may also have been perfectly sincere — the speaker may believe he is right about Paderewski. Either way, (6) is just as effective in changing the beliefs of the speaker as in the original circumstance, in which the speaker was in the right; he would just not be, in this case, relieving ignorance. Thus, what comparing these two situations shows, modulo the felicity of uttering (6), is that the informativeness of (6) is not a matter of the facts on the ground — it is independent of this — but arises from the beliefs of the speaker and hearer, and in the intention of the speaker to bring the beliefs of the hearer in line with his.

Before continuing, we need to contrast the example we are considering with one which, while superficially similar, is really of a rather different nature. So, consider a speaker who is, as before, fully aware that there is one and only one person Paderewski. He makes the following utterance:

(9) That guy is that guy.

pointing first to Paderewski as he plays the piano in the concert hall, and then pointing to him on the political rostrum.⁵ Now the structure we assign to (9) is just the same as that in (6):

(10) That guy₁ is that guy₂.

so that it too is of the form $\lceil a = b \rceil$. But here, unlike in (6), the indices are the speaker's, not the agent's; (10) is a sentence which the speaker is perfectly willing to assert on the basis of his own beliefs. Yet, it obviously must not imply that the

⁵ This example is modeled on an example of Kaplan's (1989). Of course, accomplishing such an utterance may take some considerable time, so as to allow Paderewski to change his location, but this is not necessary for an utterance of *That guy is that guy* to be informative. Imagine that one seeks to deny that someone has been instantaneously replaced by his doppelgänger; then one can utter this sentence in normal time while demonstrating the person in question as he stands rigidly before the interlocutors.

speaker believes he is referring to two different people, for the speaker believes he is uttering a truth. Why the difference between these cases?

The immediate observation about (10) is that it contains demonstrative expressions. What is different about such expressions as compared to names is that while the relation of names to their syntactic expression is mediated just by the correspondence of indices to the values a speaker believes that name to have, with demonstratives, there is another factor at work. This is that demonstratives are matched to values with respect to dated, located, oriented uses, so that, roughly speaking, for such expressions indexing is in terms of beliefs about how many *demonstrations* of the value there are. The result of this is that any demonstratives that a speaker takes to be associated with demonstrations will all be, in a given discourse, non-coindexed. This simply follows from the uniqueness of demonstrations made in real time. Differently dated demonstratives, even of the same form and used (intentionally) to refer to the same individual repeatedly, will thus be distinct expressions, bearing distinct indices. Now, applying this to (10), because the speaker believes he has made two distinct demonstrations of Paderewski, (10) will have the indexing that it does, and hence be of the form $[a = b]$. Since this indexing directly reflects the speaker's beliefs, it can be asserted as such, with speaker's indices, (and, note, regardless of whether the speaker has the name "Paderewski" in his lexicon).

While it is demonstrative expressions which are canonically backed by demonstrative reference — in the sense that indices project onto syntactic expressions in the manner described — demonstrative reference can back up the use of other sorts of expressions. Thus, we can have "quasi-demonstratives" as in "That Paderewski is that Paderewski," or, and this is the important case, we can also use, in the circumstances described, names, as in "Paderewski is Paderewski," with the first occurrence of "Paderewski" uttered accompanied by ostension to Paderewski playing the piano, and the second occurrence accompanied by ostension to him giving a political speech. But, this instance of "Paderewski is Paderewski," while having the same linguistic form as (6) — the occurrences of "Paderewski" not being coindexed — is to be carefully distinguished from (6). As the names are used demonstratively in this latter case, the sentence is assertable by the speaker, and will be comparable, at least in this regard, to "Cicero is Tully." Again, there is much more to say about this, but we leave this for another time, noting here that we have (just) two principles

for syntactically projecting indices — they reflect either beliefs about values, or beliefs about demonstrations of values.⁶

Now there is an interesting contrast to be drawn between the puzzle we have been considering and a sort of reverse puzzle, in which we turn the tables and suppose that the speaker believes, let us assume correctly (although this is not necessary — see above), that there are two people, one a pianist, one a statesman, each named “Paderewski,” but that Max holds that there is just one person named “Paderewski,” who is both a pianist and statesman. What could the speaker say to Max so as get sufficient information across to him that he will conclude that “Paderewski isn’t Paderewski” is true? Well, there are certain things which one can’t say and expect to achieve this result. For instance, making an utterance to this person intending to directly disconfirm what he already holds would be ludicrous. All he holds is that “Paderewski is Paderewski” is true, something of the form $[a = a]$. Certainly uttering its negation, “Paderewski isn’t Paderewski”, now of the form $[a \neq a]$, won’t do the trick of getting him to make a distinction where he holds none to obtain. (Except perhaps in a roundabout manner, by reasoning from: why would someone say something so stupid to me?) Apparently, then, for someone who holds incorrectly that there is but a single value when there are two, and hence holds only a logical truth, something not subject to empirical revision, there is no way to relieve him of his ignorance by use of the name “Paderewski” and identity, at least not in the direct way that uttering (6) as the negation of “Paderewski isn’t Paderewski” achieves this result in the standard case.

This is not to say, however, that Max cannot be relieved of his ignorance by some other sort of utterance. What one needs to find is something Max holds which could be false; that is, subject to empirical revision. Two options are available at this point. One is to give up using identity; in this case, uttering “There are two people named ‘Paderewski’”, directly attacking his assumption about how many people answer to the name “Paderewski”, should get the job done. The second would be to give up using names, and take to other referential devices. For instance, something that would work would be utterances of “That guy isn’t that guy” or “That Paderewski isn’t that Paderewski,” either one uttered while first pointing to the person on the concert stage, and then to the person on the political rostrum. These would be informative to Max, because they would negate, and hence disconfirm, something which Max holds

⁶ For instance, we must be careful to distinguish the case in which “Paderewski is Paderewski” is uttered with each occurrence of the name accompanied by ostension from the following case. It is possible to say “That planet is that planet”, pointing first to Venus in the evening, and then to Venus in the morning. But it would not be informative to say “Venus is Venus” in the same way.

to be true, namely "That guy is that guy" or "That Paderewski is that Paderewski," where in all these cases, since we have demonstratives, there is non-coindexing of the phrases flanking "be." Thus, through the use of demonstratives,⁷ it is possible to be informative in circumstances where using names fails to give rise to an informative identity statement. so that there is an asymmetry between the standard case and the reverse case. In either case, demonstratives can be utilized, but only in the standard case can names also be employed as well. But when they are, it can only be in utterances in which there are occurrences of what we have called "agent's indices," and the utterance itself has a special status, as it is an informative utterance which is non-assertive, as opposed to those cases in which there are demonstratives.

To this point we have considered cases in which a speaker makes an utterance to a hearer with the purpose of altering the hearer's beliefs, and in this regard we have considered two sorts of cases, the normal and the reversed, observing where they diverge. There is another way in which they differ — only in the reverse case is it possible to report the antecedent belief of the hearer by a belief-ascription whose *that*-clause has the form of an identity statement. For suppose there are a speaker and a hearer, each of whom believes there are two people, speaking of an agent who believes there is only one. It would make perfect sense for one of them to utter (11) to the other:

(11) Max believes Paderewski is Paderewski.

The structure of (11), in the circumstance given, is as in (12):

(12) Max believes Paderewski₁ is Paderewski₂.

The puzzle here is what is being attributed to Max? As discussed above, it cannot be that he believes "Paderewski₁ is Paderewski₂" is true, because no one can believe this; for the reasons discussed above, someone who holds that there are two people each named "Paderewski" would only hold "Paderewski isn't Paderewski." But if not this, what is it that the speaker is saying about Max?

⁷ Or descriptions. Thus, we could also say to Max "The statesman (Paderewski) is the pianist (Paderewski)" and achieve the desired result, (so long as Max would describe Paderewski in these ways.) Notice that there is an interesting observation here that in the epistemological context we have described, demonstratives cluster with descriptions, apparently in contrast with names. This is to be compared to modal contexts, in which demonstratives cluster with names, as opposed to descriptions, as devices of rigid (or direct) designation.

What the speaker is saying by the attribution in (12) is that the agent believes there is only one person, whereas the speaker believes there are two people named "Paderewski". He can say this by (12) because there are occurrences of distinct "Paderewski"-expressions which bear indices of the speaker (and hearer). It is he who believes that there are two people, each bearing the name "Paderewski", (so that the "Paderewski"-expressions are not believed to be coreferential), but there is no entailment that the agent shares this belief (and no implication that the agent knows the name "Paderewski"). That is, there is no implication that the indices are agent's indices. The identity sign, the verb "be", then contributes that the individuals that the speaker distinguishes are equated by the agent. The speaker is saying what the agent believes, but in terms which are relating back to the speaker and hearer's beliefs, making an implicit comparison between their beliefs and the agents. We thus have here an instance in which the sentence which follows *believe* is not itself the object of belief, but rather a sentence from which one can derive, at least conditionally, something which the agent *would* believe, if he had any beliefs about values associated with the name "Paderewski".

Notice that there is no comparable belief attribution which can be made in the normal case, the one in which the speaker believes there is one person, and the agent believes there are two. In this case, the *that-clause* of the relevant belief attribution — "Max believes Paderewski₁ isn't Paderewski₂" — does report something which Max does believe (*de dicto*), with the indices construed as agent's indices, so that the embedded clause is something which the agent would assert, as opposed to the embedded clause in (12), which he would not. If this attribution is true, it of course follows that Max believes there are two people named "Paderewski" (although clearly the speaker would have done better justice to his communicative intentions by just saying that Max believes there are two people named "Paderewski"). But this attribution is not to the same effect as (12), since it does not provide the implicit comparison of the agent's beliefs with those of the speaker. This is because the attribution is not given in the speaker's terms, with his indices, for with speaker's indices, the utterance could only have the form of attributing something logically false. Thus, we find an interesting paradigm. In the normal case, an unembedded identity statement cannot be asserted, but an embedded one can, and the corresponding belief report is *de dicto*, in the sense that the expressions used in the report are those of the agent, with his indices. On the other hand, in the reverse case, it is the unembedded statement which can be asserted, and the embedded which cannot. Hence, the belief report is *de re*, and the expressions used are the speaker's,

with speaker's indices, so that the *that*-clause does not itself specify directly what it is that Max believes.

To summarize, the analysis we have presented is based on two distinct theses, one about linguistic form, the other about linguistic use. The first is that linguistic expressions can be individuated through formal identity conditions defined over indices; coindexed occurrences are the "same"; non-coindexed occurrences "different", although difference of index is no bar to identity of reference. The second is that speakers may use expressions as they believe an agent would use them, with "agent's indices." In this case, expressions are individuated as the agent would, and not as the speaker would. It is in this sense that our utterances may be of our own sentences, or the sentences (uttered or not) of others, modified in some way or other, inclusive of their indices. The indices in our utterances, therefore, while normally those of the speaker, need not be; they may be those of others, (who may or may not be directly involved in the conversation). This capacity, bear in mind, is pragmatic — we *use* someone else's words with the import they assign to them — and not semantic. We do not take it as part of the *meaning* of an expression as used by a speaker that it is someone else's expression. These theses, we have argued, allow us to account for the puzzle of identity. They are also the foundation of our account of puzzle of beliefs, but that is another matter.

5 Concluding remarks

We began this paper with a story about Pooh and Christopher Robin, and we asked whether they had each uttered the same sentence in their remarks about honey. Well, they probably did, but it is very much less certain that Strawson's speakers did when they uttered "The King of France is wise," and it is surely the case that the speaker attributing beliefs about Paderewski didn't. As we remarked, this last case has been taken to argue that something independent of language itself, of its syntax or semantics, is needed as part of the analysis of language understanding, that some sort of conceptual analysis is needed, and someone swayed by this argument would be just as inclined to draw the same conclusion from the puzzle about identity we have been discussing here. But given our analysis of these cases, which turns on syntactic considerations of expression identity accompanied by a theory of use which distinguishes between when a speaker uses his expressions on the basis of his own beliefs about the relationship of names and values, so-called "speaker's indices," and when he uses expressions on the basis of his beliefs about an agent's beliefs about

such relationships, so-called "agent's indices," we obviously very much doubt that any such conclusion is warranted.

Put roughly, from this alternative point of view, the identity puzzle would be analyzed by maintaining that the agent associates with the person Paderewski two different modes of presentation. Such modes are usually understood as describing or specifying the concepts that an agent associates with an individual, but there is nothing which requires that the agent realize that two qualitatively distinct descriptions may be, in fact, of the same person. While this basic line of analysis can take many twists and turns so as to take on a more "Fregean" or more "Russellian" tone, the basic underlying idea remains the same: it is because the agent has distinct concepts of Paderewski, which he takes to be concepts of different people, that it is possible for "Paderewski is Paderewski" to be informative. The puzzle, on this view, is ultimately about the modes of presentation of objects, the cognitive significance of the identity statement resulting from there being different modes presenting a single individual, viz. Paderewski.

There is much, we believe, to criticize in this perspective on the identity puzzle, especially when one considers the full range of puzzling cases, but we shall not undertake this task here. Rather, we wish only to briefly remark on how given this way of thinking about the puzzles, our analysis is to be taken. The first question to be asked is what are the modes of presentation? Or, to put the question better, as Schiffer (1990) puts it, what *plays the role* of modes of presentation in our theory? Put thus in a functional way — by which the modes of presentation are whatever it is in a theory from which it follows that an agent can both rationally believe and disbelieve the same "proposition", so long as whatever plays this role can be defined non-circularly — the answer to the question is that the modes of presentation are the indexed expressions. It is by their use that the speaker can report, for instance, that an agent (which may be the speaker himself) both believes and doesn't believe, for instance, that Paderewski is a genius, and it is for such an agent that an utterance of "Paderewski is Paderewski" will be informative, for it is he who believes that Paderewski isn't Paderewski. The virtue of indexed expressions as modes of presentation is that there are precise, independent *syntactic* criteria by which they may be individuated, criteria which we have outlined above and which are developed more fully in *Indices and Identity*. Our theory thus meets a challenge put by Schiffer (1990:257) that "words" can't play the role of modes of presentation "until we are given the intended method of word individuation" without "appeal to word meanings."

Now what of cognitive significance? If capturing the modes of presentation, however conceived, is what constitutes *cognitive significance*, that aspect of the thought of speakers such that they can make the sorts of distinction forced by the puzzles of identity, then we have put forth a case that language, with respect to the formal syntactic structure of (indexed) expressions, is cognitively significant. This result is perhaps not particularly surprising; its epistemological status is no different from saying that the difference between a phrase being a noun phrase or a verb phrase is cognitively significant to speakers, at least in the sense that grammatical properties are tacitly known to speakers of a language. But there is something more to the cognitive significance of indexed expressions, since, we have argued, they reflect beliefs concerning how agents use different expressions derived from the same name, believing that there are two different people with the same name. These beliefs are by no means tacit, but are consciously known, and can be reported by speakers. But where our theory stops short is that nothing further follows about why someone might hold these beliefs, his particular grounds or causes for holding that a particular name is associated with some number of values.

Notice that nothing in the functional way of understanding the question of what modes of presentation are presupposes that they are conceptual, and on our theory they are not, nor, on our view, should they be. It would not, for instance, fall within our view to liken indices to footnote markers, where the footnotes themselves describe how an agent conceives of an individual, (which seems to be what is envisaged in Bilgrami, 1992). We, of course, are not denying that agents have concepts of individuals. Indeed among the grounds an agent may have for his beliefs as to the values associated with names may be the concepts he associates with individuals. Insofar as individuals are sufficiently intimate with the agent, such concepts may be sufficient to uniquely identify those individuals, but they are surely not necessary. For instance, with historical figures, an agent may associate a set of conventionally determined concepts which amount in reality to nothing more than a good yarn, and it may be that in many cases people just rely on a primitive view that different names normally are of different people. But be this as it may, the point is that this is not at all relevant; what is relevant, on our point of view, are the agent's beliefs as to how many values are associated with a name — the particular grounds he may have for those beliefs is not germane. To put this another way, however an agent may conceive of an individual, it is not a mode of presentation in our theory.

To conclude, it is our view that a primary lesson to be learned from the puzzle about identity is one about the nature of syntactic identity, about what constitutes the same or different expression, and ultimately what constitutes the same or different

logical form. Thus, by our account, the identity puzzle is first and foremost a puzzle about the sentential forms through which an informative identity statement can be uttered. The distinctions which need to be made are, in our view, ones which are made linguistically; once this point is taken, one ends up with a rather different view of the role of syntax and semantics in language understanding and communication as this relates to how people conceive of objects. In this paper, we have been able to only give the barest sketch of these consequences; our goal has been only to develop the initial linguistic and philosophical plausibility of our approach. Its full development must wait for another occasion.

References

- Bilgrami, Aneel. 1992. *Belief and Meaning*. Oxford: Blackwell.
- Crimmins, Mark. 1992. *Talk About Beliefs*. Cambridge, Mass.: MIT Press.
- Evans, Gareth. 1980. Pronouns. *Linguistic Inquiry* 11. 337-362.
- Fiengo, Robert and Robert May. 1994. *Indices and Identity*. Cambridge, Mass.: MIT Press.
- Fiengo, Robert & Robert May. 1997a. Interpreted Logical Forms: A Critique. To appear in *Rivista di Linguistica*.
- Fiengo, Robert & Robert May, 1997b. Names and Expressions. Ms. Queens College and The Graduate Center, City University of New York and University of California, Irvine.
- Higginbotham, James. 1983. Logical Form, Binding and Nominals. *Linguistic Inquiry* 14. 395-420.
- Higginbotham, James. 1985. On Semantics. *Linguistic Inquiry* 16. 547-594.
- Kaplan, David. 1989. Demonstratives. In J. Almog, J. Perry and H. Wettstein (eds) *Themes from Kaplan*. Oxford: Oxford University Press.
- Kripke, Saul. 1979. A Puzzle About Belief. In A. Margalit (ed.) *Meaning and Use*. Dordrecht: Reidel.
- Larson, Richard and Peter Ludlow. 1993. Interpreted Logical Forms. *Synthese* 95. 305-355.
- Lasnik, Howard. 1976. Remarks on Coreference. *Linguistic Analysis* 2. 1-22.
- Perry, John. 1988. Cognitive Significance and New Theories of Reference. *Noûs* 22. 1-18.
- Recanatì, François. 1993. *Direct Reference*. Oxford: Blackwell.
- Salmon, Nathan. 1985. *Frege's Puzzle*. Cambridge, Mass.: MIT Press.
- Schiffer, Stephen. 1990. The Mode-of-Presentation Problem. In C.A. Anderson & J. Owens (eds) *Propositional Attitudes: The Role of Content in Logic, Language and Mind*. Stanford: Center for the Study of Language and Information.
- Strawson, Peter. 1956. On Referring. In A. Flew (ed.) *Essays in Conceptual Analysis*. London: Macmillan.

Pronouns and Agreement: Systems Interaction in the Coding of Reference

Zygmunt Frajzyngier

1 The problems*

The assumption that a category pronoun, with cross-linguistically homogeneous features exists does not explain the very significant differences in the properties of pronouns across languages. The first problem is that the pronominal subjects of embedded clauses have different binding properties. Consider complements of verbs of saying. In English (1), the pronoun *she* is coreferential with the subject of the matrix clause.

(1) because ^Sall 'said shèd 'like a "!!Guinness you s/œ# (LL corpus)¹

* I would like to thank Aaron Broadwell for comments and constructive criticism of the previous version of this paper. Work on this paper was supported by an NSF grant *Grammars of Gidar, Mina, Lele, and East Dangla*. Data on Lele were gathered as part of an NEH supported work on Complex Sentence in Chadic.

¹ Whenever possible the data for analyses are drawn from corpora of natural discourse. In case of less familiar languages, elicited sentences are sometimes used in order to facilitate the understanding of the phenomena involved.

In certain cases, corpus data may contradict the *elicited* judgments of speakers. In such cases the corpus data are taken to represent the usage. The study of why the elicited judgment of speakers differs from their usage is beyond the scope of the present paper. What the speakers say they do with respect to language is quite often different from what they actually do. Such contradictions are of course not limited to language alone.

The quoted material is given in the transcription used in the source. The material quoted later from Nitsch (1961) is given in slightly modified transcription.

In Polish the situation is quite different. The pronoun *wuni* '3MPL' in the embedded clause of (2) encodes switch reference with respect to the subject of the matrix clause.

- (2) A wuni muvjili, že wuni maju
 A.CONJ 3PL say:PAST:3PL COMP 3PL have:PRES:3PL
 dosydz żyvności kedy xlebam stsýlja ju
 enough food when bread:INSTR shoot:PRES:3PL
 'And they₁ said that they₂ have enough food if they₂ use bread for shooting.' (Nitsch 1960:245)

In Mupun in example (3) the pronominal subjects of the embedded clauses can only be coreferential:

- (3) wu/wa/mo sat nə ta d'i/d'e/d'u d'ee n-jos
 he/she/they say COMP stop he/she/they stay PREP-Jos
 'He₁/She₁/They₁ said that he₁/she₁/they₁ stopped over in Jos.'
 (Mupun, Frajzyngier 1993:108)

In Mupun in example (4) the pronominal subjects of the embedded clause can only be switch reference:

- (4) wu/wa/mo sat nə wu/wa/mo n d'ee n-jos
 he/she/they say COMP he/she/they stop stay PREP-Jos
 'He₁/She₁/They₁ said that he₂/she₂/they₂ stopped over in Jos.'
 (Frajzyngier 1993:108)

The morpheme *she* in the embedded clause of (1) is considered a pronoun. Sentences (2) through (4) have exactly the same structure, hence there is no syntactic reason to consider the forms occurring there to be anything but pronouns as well. All of these pronouns, and also those that occupy the position of the subject of the matrix clause, share the property of coding person, gender, and number, but they vary in their binding properties. Thus instead of postulating a homogeneous grammatical category 'pronoun', it is necessary to differentiate among several categories of pronouns.

The traditional approach to pronouns cannot explain the differences in the interpretation of sentences (5) and (6):

- (5) yàá-dú nā b̀̀y-dú k̀̀j̀̀ò k̀̀-t̀̀ó
 say-3F COMP break-3F hoe GEN-3F
 ‘She₁ said that she₂ broke her_{1/2} hoe.’
- (6) yàá-dú nā dú b̀̀y k̀̀j̀̀ò k̀̀-t̀̀ó
 say-3F COMP 3F break hoe GEN-3F
 ‘She₁ said that she₁ broke her_{1/2} hoe.’
 (Lele, East Chadic, Frajzyngier in progress)

The second problem is that the traditional approach to pronouns cannot explain why in the following sentence the second person masculine pronoun is used despite the fact that the language has a choice between second person masculine and second person feminine:

- (7) gaskiya, get kadan ka kə aak ʃe
 truly (H.) past if (H.) 2M with pregnancy CONS
 ba də mo pə ʃal d'ik n-ka
 NEG PAST 3PL PREP marry PREP-2m
 ‘Truly, in the past if you were pregnant they wouldn't marry you.’
 (Mupun, Central Chadic, Frajzyngier 1993:88)

The third problem is whether there is a connection between the binding properties of pronouns and (a) the type of constructions in which they occur and (b) other reference coding means available in the language.

2 The goal and scope

The main goal of the present paper is to reanalyze the category pronoun as commonly understood in most syntactic theories. As a result of this reanalysis several types of pronouns are proposed for a taxonomy of pronouns. The paper presents two main hypotheses and several auxiliary ones: (1) The category pronoun in cross-linguistic typology consists of different types of morphemes, varying in their binding properties and in their functions. (2) The category pronoun is just one of several means of

encoding reference in language. The various coding means are complementary in that the functions encoded by one system are different from the functions encoded by another system.

The analysis is limited to four types of languages: languages without a system of coding arguments on the verb (agreement) and with only one set of pronouns, such as English; languages without an agreement system but with several sets of pronouns, such as Mupun; languages with one set of pronouns but with a rich agreement system (Polish); and language with one set of pronouns, with a split agreement system, and in which the agreement system and some pronouns are mutually exclusive within the same clause, such as Lele. The core of the argumentation is an analysis of the means of coding switch reference and coreference for third person arguments in complements of verbs of saying and in discourse. These two syntactic environments have been chosen because potentially they are the most opaque with respect to the reference of pronominal participants. In order to draw generalizations, it will be necessary to examine also other grammatical constructions.

The system of coding coreference and switch reference interacts in an interesting way with other functions performed by reference system. In the present paper I discuss the interaction with the coding of the *de dicto* domain.

The auxiliary hypotheses are as follows: (1) With respect to complements of verbs of saying, though not necessarily other constructions, which are potentially less opaque. I propose that if a language encodes the distinction between coreference and switch reference through a system of pronouns,² the following principle holds in complements of verbs of saying: If a language has a pronominal form encoding antecedent, the same form in the same syntactic position is deployed to code switch reference. A different form examples (2-4) or a different syntactic position examples (5-6) are deployed to code coreference. The importance of this hypothesis is that it provides a partial account for two elements of the taxonomy of pronouns: pronouns that are bound within a sentence and pronouns that are not bound within a sentence. It also provides an explanation for difference between sentences (5) and (6). This hypothesis contradicts the central intuition of Fiengo & May (1994) according to which 'if an expression is repeated, it follows that the two occurrences have the same semantic value, in the cases at hand, its reference. (Fiengo & May 1995:794).

² Languages may encode the distinction between cross-reference and switch reference through means other than pronouns. In Hua (Papuan) the means of encoding switch reference is through affixes to the verb (cf. Haiman 1983), cf. also Broadwell (this volume). The present paper is not concerned with these other mechanisms that languages may deploy.

There is a hierarchy of structures where the means of coding switch reference and coreference are deployed: first in clausal complements of verbs of saying, then in complements of cognitive verbs, and finally in conjoined sentences. Consistent with the proposed hypothesis, simple sentences in discourse may also be marked for switch reference.

The second hypothesis has to do with other coding means available in language: (2) If the verb encodes the subject of the clause (agreement), there exists a functional differentiation between the pronouns and the argument coding on the verb. Determination of which coding means carries which functions must be made for individual languages. In some languages pronouns carry pragmatic functions, one of which is switch reference (cf. (2)).³ The coding of the subject (and other arguments) on the verb indicates referentiality, definiteness, and possibly other functions in the general domain of pragmatics. But it is theoretically possible that the distribution of functions between the coding on the verb and pronouns is different, and that pronouns encode coreferentiality within a sentence whereas coding on the verb encodes switch reference as in (5-6). Hence in addition to the taxonomy of pronouns we must have a taxonomy of head coding, in particular, a taxonomy of argument coding on the verb. Therefore, both taxonomies are proposed in the present paper.

The following are case studies organized according to the various functions the pronouns have with respect to cross-reference and disjoint reference coding.

3 Nondifferentiated pronouns

English has only one set of pronouns. Subject coreference is indicated in many constructions through the omission of subject pronouns, e.g.:

- (8) 4_7_0 <765 b> and his ^wife 'ran a" wVay# -
4_7_0 <766 b> and ^had a 'child by an:other bl/oke# -(LLC)

The agreement system is limited to only one tense and one person. Sentential complements of verbs of saying must always have a subject; hence subject omission is not a viable means of encoding coreference. Omitting the embedded subject from the following sentence would result in an ungrammatical construction:

³ The fact that pronouns in such languages carry a pragmatic function was already noted by Meillet (1937). Cf. also Dik (1989).

- (9) (and)) I said I haven't used a ^sewing-machine for/ !!years# (LLC)

There have been some claims that pronominal subjects of an embedded clause are potentially ambiguous and could refer to the subject of the matrix clause, the addressee of the matrix clause, or a non-participant in the conversation, and the distinction between various types of binding is coded through prosodic means. Clements (1975:147) quoting work of Cantrall (1975) and Cooper (1976) points out that stress is not a reliable indicator of coreference, but that duration may be.

My own perusal of the London-Lund corpus of spoken English shows that in all cases where the third person pronominal subject of the embedded clause shares the features gender and number with the subject of the matrix clause, coreference is the norm. Here are some of the examples drawn from that corpus:

- (10) the ^president said she had :g\athered# ^from my - - ^some of my
re:marks over :l\unch that [@m] I ^wouldn't want to !!ive - - in the
c/ollege#

In most cases the pronominal subject of the embedded clause is coreferential with the subject of the matrix clause if they agree in gender and number, e.g.:

- (11) 1_4_0 <1094 B> but ""h\alf of them had r/ead it#
1_4_0 <1095 B> and the ^others 'said they 'wanted :me to !t\alk a'bout it#
- (12) 1_4_0 <1112 B> *((yeah)) at the ""last* 'faculty of \arts meeting#
1_4_0 <1113 B> they ^said they'd !\ask the _provost#
- (13) 1_5_0 <919 A> ^and my plarents were 'so fed 'up with me#
1_5_0 <920 A> that they said ^hey w\ere 'fed up of supp/orting you#
- (14) 1_6_0 <725 B> I ^didn't s\ee him ((en/ough#))
1_6_0 <726 B> but ^Gloria said she saw . was ^t\alking to 'him#
- (15) 1_6_0 <1136 B> ^said to 'me /once# -
1_6_0 <1137 B> that he ""f/elt#
1_6_0 <1138 B> that [?]if - 'Doc :M\iddleton# .
1_6_0 <1139 B> ((was)) ^coming ":d\own the 'stairs#

- (16) 1_8_0 <373 A> ^well ^hè's just l'eft {the ^skirting b'oard#}
 {when he ^\finished#}#
 1_8_0 <374 A> he ^said he !c'ouldn't 'do an' other 'five h/ours -
 {which is ^all it n/eeds#}# -
- (17) 1_9_0 <952 A> (laughs -) ^they 'said they !weren't {s\ure} of
- (18) 6_8_0 <117 B> +yes+ well ((the girl)) said that she was very
 worried about his *((several sylls))* the :f'ind 'spot# .
- (19) well ^Nightingale :said that he . he :might want to/
 :get a:way from . Lower N\etherhall you s/ee
- (20) 5_8_0 <570 b> and [@m] - . she ^just said _well she just .
 " !didn't 'think she could 'make it on 'Friday n/ight#
- (21) 6_8_0 <107 B> they said that this they do [?] anyway they have a
 lot of time together and they always have all their/
 meals together - and they talk about all sorts of things -
- (22) 8_4_9 <586 A> and ^they !said _they'd 'written it :d\own *but##
- (23) 9_2_2 <173 A> ^does he {kn'ow} :Doctor S\owerbarn# -
 9_2_2 <174 B> ^[j@ ? w] ^y\es#
 9_2_2 <175 B> ^he !said he :d\id#

The third person embedded clause subject pronoun that shares the features gender and number with the matrix clause subject encodes switch reference only if it is in direct speech, which may be signaled by a number of prosodic or syntactic devices. Here is an example:

- (24) 4_7_0 <541 a> so the ^man said !!w\ell# .
 4_7_0 <542 a> he was ^digging 'up !my r\oses#

A perusal of the Brown corpus of written English indicates virtually the same property. The third person pronoun of the embedded clause is coreferential with the subject of the matrix clause if they agree in gender and number, e.g.:

- (25) The jury said it did find that many of Georgia's registration . . .
- (26) The jurors said they realize "a proportionate distribution
 of these funds might disable this program in our less populous counties".
- (27) Ratcliff said he expects to tell home folks in Dallas why he thinks
 Berry's proposed constitutional amendment should be rejected.

One of the systematic means to encode switch reference in the LL corpus is to use a full noun phrase, as in the following:

- (28) Alec had to ring me about examin:\ation _business#/ this ^mVorning#
and ^he said he ^happened to !mention that Oscar was a:way for a
couple of :dVays# - . ^but will be !back [@:m] on :M\onday
(({ or therea^b\outs# } #)) .
- (29) I mean* ^this . [@] ^Mallet said ^Mallet was [@] ^said something
a!bout [@] you know he ^felt it would be a good thing if [@:] . if
Oscar :w\ent#
- (30) 6_7_0 <678 a> remember Brockhouse had said that Frank Jones made
a great mistake in not retiring from politics at the end of the
First World War

In the whole LL corpus there are very few examples where the 'agreeing' pronominal subject of the embedded clause must be construed as disjoint reference. One is where the pronoun of the embedded clause encodes the topic of the paragraph and the matrix clause preceding it, is a parenthetical remark:

- (31) 10_1_0 <751 ra> and he ^never looked h\appy#
10_1_0 <752 ra> he ^never looked con:t=ent# .
10_1_0 <753 ra> ^and as :Norman :Yardley said he :spent his :time
playing b\ack# -
10_1_0 <754 ra> and ^paid the !penalty in the !end# - - -

Based on this sample only, one could say that if the pronominal subject of the embedded clause shares the features of gender and number with the subject of the matrix clause, the third person pronoun of the embedded clause encodes coreference with the subject of the matrix clause. But written English, especially artistic prose, contains data in which a subject pronoun must be construed as encoding switch reference. Compare the following fragment, which occurs at the beginning of a paragraph. In the second sentence of the fragment, the two pronouns 'he' have different referents:

- (32) As an archer he was without equal. My grandfather said he could hit a moving buck at 150 yards, adding that he would not have liked to expose any part of himself in battle to a Bushman archer under 150 yard's range. But he not only hunted with bow and arrow.
(van der Post 1986:10)

The conclusion for English is that there is no differentiation in the pronominal system or in the coding on the verb for encoding the distinction between switch reference and coreference. The absence of differentiation in the pronominal system and the absence of other means of coding reference explains the very frequent usage of direct speech to assure proper interpretation in conversational English, as represented by the LL corpus.

4 Logophoric pronouns: the sentence as a binding domain

The following terms are necessary for understanding the argumentation: A pronominal antecedent is a pronoun that occurs in the matrix clause in a complex sentence or in a preceding clause in discourse. A logophoric pronoun is a pronoun that is bound by an argument of the matrix verb of saying (this formulation is more restrictive than the one found in Hagège 1974). This argument may be the subject or the addressee of the matrix clause; hence a clause may contain a logophoric subject or a logophoric addressee (Frajzyngier 1985, 1989).

In many languages from different families the logophoric pronouns have a different form from that of the matrix pronouns. The pronouns identical with the matrix pronouns are used to encode switch reference. Compare the following data from Ubangi languages spoken in the Central African Republic (data from Cloarec-Heiss 1969:61ff) with terminology as presently understood):

Table I

Language	Matrix pronoun	Logophoric	Switch reference
Banda	ɔ̃	ə̃nɛ̃	ɔ̃ɛ̃
Ngbaka	xɛ̃	xɪ̃	xɛ̃
Gbandili	xã	xĩ	xã

In Ewe (Kwa branch, Niger-Congo) the antecedent third person pronoun is *e*. The logophoric pronoun is *yè* (Clements 1975:142).

In Igbo (Niger-Congo) the antecedent third person is *ó* and the logophoric is *yá*. In Gokana (Cross-River, Benue-Congo, Niger-Congo) the antecedent is *àè* preceding the verb, and the logophoric marker is *E* suffixed to the verb (Hyman & Comrie 1981:69).

Mupun (West Chadic), an SVO language, does not have a system of argument coding on the verb. In Mupun there exist two series of logophoric pronouns, one bound by the subject of the matrix clause and the other by the addressee of the matrix clause. Both types of logophoric pronouns have different forms from that of antecedents. If the complement clause pronouns are identical with the antecedent, they are not bound by the antecedent. The following table gives the form of logophoric and switch reference pronouns in Mupun:

Table 2

Person	Antecedent subject	Log. subject	Antecedent addressee	Log. addressee	Switch reference
3M	wù	dī	wùr	gwàr	wù
3F	wà	d'è	wàr	páa	wà
3PL	mō	d'ū	mò	nūwā	mō

Examples (tones unmarked):

- (33) wu/wa/mo sat nə ta dī/d'e/d'u d'ee n-jos
 he/she/they say COMP stop he/she/they stay PREP-Jos
 'He₁/She₁/They₁ said that he₁/she₁/they₁ stopped over in Jos.'
- (34) wu/wa/mo sat nə wu/wa/mo ta d'ee n-jos
 he/she/they say COMP he/she/they stop stay PREP-Jos
 'He₁/She₁/They₁ said that he₂/she₂/they₂ stopped over in Jos.'
- (Frajzyngier 1993:108)

Examples of coding logophoric and switch reference addressees:

- (35) n-sat n-wur nə gwar ji
 1SG-say PREP-3SG COMP 3SG come
 'I told him₁ that he₁ should come.'
- (36) n- sat n- wur nə wur ji
 1SG-say PREP-3SG COMP 3SG come
 'I told him₁ that he₂ should come.' (Frajzyngier 1993:112)

The two sets of pronouns in Mupun are deployed mainly in complements of verbs of saying. In other environments, including complements of other verbs, only the pronouns from the antecedent set are used and consequently the grammatical system allows for ambiguous interpretation. The ambiguity must be resolved by the context, as in the following sentences:

- (37) amma kat ba me mat ta tok kə mo kas
 but (H.) when NEG QUANT woman fall greet CONJ 3PL NEG
 dʒ mo seet dak ʃe mo n-dəm ter a yil
 then 3PL depart just CONS 3PL FUT-go spend the night PREP bush
 'But if there is no woman who comes across and greets them they will just go and spend the night in the bush.' (Frajzyngier 1993:509)
- (38) kat wur naa ngo dʒə ba wur ʃal kas
 when 3M see man REL NEG 3M strong NEG
 ʃe wur dəm pe mənə kə wur put dʒi
 CONS 3M go place ANAPH COMP 3M leave COMP
 'When it [the leopard] sees a man who is not strong then it goes in that direction so that it can get out.' (Frajzyngier 1993:511)

The facts presented by languages with logophoric pronouns indicate that two types of pronouns exist, one bound within a sentence and the other not and that the antecedent is bound within the discourse.

5 Switch reference pronouns and the function of agreement

Polish has subject pronouns differentiated for three persons and three genders in the singular and three persons and two genders in the plural. The past tense of the verb

differentiates among three persons and three genders in the singular and three persons and two genders in the plural. The present and the future forms encode person and number but not gender. Because there is such a rich system of coding on the verb, subject pronouns can be deployed for other functions. I propose that one of these functions is switch reference. Here is an illustration and the evidence for the hypothesis.

The following sentence has a subject pronoun before the embedded clause verb in the future tense. If the pronoun were omitted, the subject of the embedded clause would be identical with the subject of the matrix clause:

- (39) Otec móvi, ze né vé,
 father say:3SG:PRES COMP NEG know:3SG:PRES
 cy uona přystaňe.
 whether 3F agree:3SG:FUT
 'The father₁ says that he₁ does not know whether she will agree.'
 (Nitsch 1960:138)

In the following sentence, the third person subject in the apodosis clause is marked by the third person plural pronoun *wuni*. The context clearly indicates that this pronoun encodes a subject different from the third person plural subject of the protasis clause:

- (40) To bylo tutaj jak Šfydy vojovali,
 it was here when Swede:PL fight:3PL:PAST
 to wuni tam šaňec wusypali
 DEM 3PL there rampart pour:PAST:3PL:M
 'It was here, when Swedes (1) were fighting, they (2) built a
 rampart over there.'

In the following sentence, all clauses except the last one have the same subject. The nominal subject is present in the first clause but is coded on the verb in the remaining clauses, except for the relative clause, where the subject is different and is marked by the noun *Š'fydy* 'Swedes':

- (41) *ji* *p'jekaže* *po-vyskrobyvali* *s* *korytuf*
 CONJ bakers PL-scrape:FREQ:PAST:3PL:M from trough:PL:GEN
ji *wup'jekli* *xlip* *ji* *vystšeli* *tam* *gdzie*
 CONJ bake:PAST:3PL:M bread CONJ shoot:PAST:3PL:M there where
te *Šfydy* *mieli* *ten* *wobus*
 DEMSwedes have:PAST:3PL:M DEM camp.⁴
 'bakers scraped the troughs clean, baked the bread [from the scraps], and
 shot [the bread] in the direction where the Swedes had their camp.'

The above sentence is followed in the text by the following sentences whose third person subject is the pronoun *wuni*. The use of this pronoun is motivated by the fact that there is again a change of subject from the preceding sentence. The embedded clause also has the third person plural *wuni* because again there is a change of subject. In the third clause there is no pronoun because the subject is coreferential with the subject of the preceding clause:

- (42) *A* *wuni* *muvjili*, *že* *wuni* *maju*
 A.CONJ 3PL say:PAST:3PL COMP 3PL have:PRES:3PL
dosydz žyvności kedy xlebam *stsylaju*
 enough food when bread:INSTR shoot:PRES:3PL
 'And they₁ said that they₂ have enough food if they₂ use bread for
 shooting.' (Nitsch 1960:245)

In the following fragment, the first sentence has third person plural subject. In the second sentence there is a switch of subject to third person masculine singular, and accordingly this is done with the third person pronoun:

⁴ Demonstratives (DEM) in this and other non-literary texts mark previous mention in discourse, the function similar to that of the English definite marker.

- (43) Śe drudzy napili ji zaro posnyli,
 REFL other:PL drink:PAST:PL:M CONJ soon fall asleep:PAST:PL:M
 że nic wo ničym nie védzieli.
 COMP nothing about nothing NEG know:PAST:PL:M
 'Those others drank, and soon fell asleep, not knowing anything around them.'
- (44) A wun cisnuw te košyčysko, . . .
 A.CONJ 3M throw:PAST:3:M DEM basket
 'And he threw away that basket . . .' (Nitsch 1960:242)

Consider now a fragment of text consisting of two sentences. The first sentence has three clauses, each with different subject. The subject of the first clause is coded only on the verb, and it is coreferential with a preceding subject. The second clause has the subject *batog* 'whip'. The third clause has the subject *xtoż* 'somebody'. The second sentence has the subject identical with the subject of the first clause. But since there was another subject in between, the subject of the third clause is marked by the pronoun *on*: '3M,SG':

- (45) I jak vyšoł s koścóła już
 CONJ when leave:PAST:3MSG from church already
 batoga ni hyło, xtoż ukrat.
 whip:GEN NEG be:3N somebody steal:PAST:3MSG
 'When he left the church, the whip was not there. Somebody stole it.'
 I on zaklon:
 CONJ 3M curse:PAST:3MSG
 'And he cursed.' (Nitsch 1960:145)

Omission of *on* in the above sentence would result in an interpretation whereby the person who stole the whip was also the person who cursed. The interpretation resulting from the omission of the pronoun is the evidence for the switch reference function of the pronoun.

A perusal of spoken texts in Nitsch (1960) shows that every usage of third person pronouns *on* '3MSG', *ona* '3FSG' *one* '3FPL' and *oni* '3MPL' before a verb is a case of subject switch reference. The same switch reference function of pronouns can be observed in contemporary literary Polish:

- (46) tak zrobiłby każdy z nas, ale to jest
 so do:3M:HYP each PREP 1PL but this is
 za proste. On wolał stanąć do raportu.
 too simple. 3SG:M prefer:PAST:3SG:M stand:INF to report
 'Each of us would have behaved like that. But that is too simple. He
 preferred to report for reprimand' (Sources)⁵
- (47) kiedy ja stąd wyjadę, on będzie miał ...
 when 1SG from:here leave:FUT:1SG 3SGM FUT:3SG have:3SG:M
 'When I leave, he will have ...' (Sources)
- (48) Wy mówcie, a on będzie słucał
 2PL speak CONJ 3MSG FUT:3SG listen:3SG:M
 'you speak, and he will listen' (Szpotkański, *Poemat o Szmaciaku*)

The third person pronoun does not necessarily encode switch reference with respect to the subject of the preceding clause. It may encode switch reference with respect to the potential antecedent. Thus the pronoun may be used to disambiguate between the third person masculine and the third person feminine antecedent, as in the following example:

⁵ Literary Polish examples are taken from samples used in preparation of Kurcz et al. (1990), *Słownik frekwencyjny polszczyzny współczesnej*. The electronic media through which I had access to the material, courtesy of Zygmunt Saloni, do not allow identification of the source of every sample. These examples are later identified as Sources. I had access to Szpotkański's poem also through the electronic media; hence no publisher or page references are indicated. Because of understandable space limitations the number of examples in this paper is kept to a bare minimum.

- (49) odkaed jednak kierownik skupu Bolek Domagała
 since however manager acquisition:GEN B. D.
 został oficjalnym narzeczonym Stasi Rosłoń poczuł
 become:3M:PAST formal fiancé S. R.-GEN feel:PAST:3MSG
 się tak pewnie, że jawnie przechwalał się
 REFL so sure COMP overtly boast:PAST3MSG REFL
 przed ludźmi, jak on to nabiera
 in front people:INSTR how 3M DEM cheat:PRES:3SG
 głupich urzędników.
 stupid:PL:ACC clerk:PL:ACC
 'When the manager of acquisitions B.D. became the formal fiancé of
 S.R., he openly boasted of how he hoodwinks stupid clerks.' (Sources)

We can now compare the English and the Polish coding systems with respect to reference in the same syntactic constructions. In Polish, argument coding on the verb indicates coreference with the preceding subject. The subject pronoun preceding the verb encodes switch reference. In spoken English the subject pronoun preceding the verb encodes coreference. Switch reference in spoken English is coded through the use of a full noun or through the deployment of direct speech. The use of pronouns in English corresponds thus to the coding on the verb in Polish rather than to the use of pronouns in Polish.

6 Split-agreement system and syntactic coding of logophoricity

Lele is an East Chadic, SVO language spoken in the Kelo district, Chad Republic.⁶ The language has an interesting split-pronominal system whereby the first and second person pronouns in matrix or independent clauses occur before the verb but the third person masculine, feminine, and plural pronouns occur after the verb. The following table illustrates pronominal marking on the verb è 'go':

⁶ All data on Lele are from my own fieldnotes and work in progress. The published work on Lele (Weibegué 1992 and Weibegué & Palayer 1982) does not address the problems of the binding of pronouns.

Table 3

	Singular	Example	Plural	Example
1	ḡ-	ḡè	nī INCL.	nī-è
2M	gī-	gīè	ngū	ngū-è
2F	mē-	mē è		
3M	-dī	è-dī	-gé	è-gé
3F	-dú	è-dú	Indefinite human gē	gē è

If the verb begins with a consonant, the first and second person pronouns are not prefixed to the verb but occur as separate words. The pronouns following the verb are suffixes and therefore can be considered to be a system of coding on the verb, 'agreement' in traditional terminology. The interest of Lele is first, that it provides evidence that the pronominal coding on the verb is not an agreement system in the sense of an element in the clause triggering the presence of some formal characteristics on another element, and second, it encodes logophoricity through syntactic and not morphological means.

6.1 Coding on the verb is not an agreement system

Natural discourse in Lele provides evidence that the coding on the verb is not an agreement system. The third person singular pronouns are not used in the same clause in which an overt nominal subject is used, e.g.:

- (50) gilkínín è sùk līḡdà
 Gilkinin go market yesterday
 'Gilkinin went to the market yesterday.'

In the texts gathered there is no single third person subject suffix occurring in the same clause in which there is an overt nominal subject. Attempts to insert a pronominal subject in clauses occurring in natural discourse resulted in ungrammatical constructions. In the following sentence, taken from a narrative, there is no third person subject pronoun:

- (51) kùrmbàlō né bè gē kāyā máànì tù
king do BEN 3PL thing so all (Fr)
'The king made things so for them.' (i.e. as they asked)
- (52) *kùrmbàlō né-dí bè gē kāyā máànì tù
king do-3M BEN 3PL thing so all (Fr)
'The king made things so for them.' (i.e. as they asked)

Even when an elicited sentence was situated within a natural discourse, it was not acceptable with a nominal subject and with a subject pronoun:

- (53) tērēn-dì né bè-gē kāyā máànì tù
daughter-3M do BEN-3PL thing so all (Fr)
'His daughter made things so for them.' (i.e. as they asked)
- (54) *tērē-n-dì né-dú bè gē kāyā máànì tù
daughter-3M do-3F BEN 3PL thing so all (Fr)
'His daughter made things so for them.' (i.e. as they asked)

So the coding on the verb of the third person singular masculine and feminine subject in Lele provides powerful evidence for the independence of this coding means. It is not triggered in any way by the nominal subject present in the clause.⁷ The coding of the subject on the verb is not an agreement system. This poses a natural question about the function of the coding on the verb. We have already seen in Polish that the subject marking on the verb encodes coreference with the immediately preceding subject, either within the same clause or in a preceding clause. Given this fact and similar facts in other IE languages, one would expect that marking of the subject on the verb also encodes coreference. But that is not the case for third person singular subjects. The

⁷ In data obtained through elicitation, a clause with a nominal subject may optionally also have the third person subject suffix added to the verb, e.g.:

- (i) cànìgè ām-dí lūḡmbā
canige domesticate-3M horse
'Canige broke a horse.'
- (ii) gilkínfn è-dú kàsùgú lìḡdà
Gilkinin go-3F market (local) yesterday
'Gilkinin went to the market yesterday.'

These two sentences are examples of elicited data being different from the ones found in a corpus.

third person plural suffix on the verb may, however, cooccur with the third person nominal subject. This fact will be explained later in this paper.

6.2 Logophoricity in Lele

Complements of verbs of saying in Lele provide the evidence that the third person singular pronoun when coded on the verb cannot be bound within a sentence. That is most clearly evident when the subjects of the matrix and the embedded clause are different, e.g.:

- (55) η-yàá ná bùy-dú kójò kè-tó
 ISG-say COMP break-3F hoe GEN-3F
 'I said that she broke her hoe.'
- (56) η-yàá ná bùy-dí kójò kè-i
 ISG-say COMP break -3M hoe GEN-3M
 'I said that he broke his hoe.'

When the subject pronouns of the complement of the verb of saying follow the verb, i.e., when they have the same syntactic position as pronominal antecedents, they encode switch reference as in (5). If the pronominal subjects of the complement clause precede the verb, they encode coreference as in (6). Thus the coding in Lele supports the hypothesis that different means are deployed to code coreference and the same means are deployed to code switch reference. In addition to examples (5-6), which were elicited, compare the following examples, taken from natural discourse:⁸

- (57) tōrmò-η na dú òdè ná bà-tó d'è
 girl-DEF COMP 3F go CONJ father-3F NEG
 sé kāl è-gé ná kāmḍā sùbù
 got up pass go-3PL CONJ wives three
 'The girl said that she would not go with her father, she passed [from
 her father to the man] and he went with three wives.'
 (lit. 'they went with three wives')

⁸ In Lele, as in many Chadic languages (cf. Frajzyngier 1996) the verb of saying is most often omitted in natural discourse. The complementizer or an auxiliary is the evidence that the predicate of the clause is a verb of saying.

- (58) ntóormò nā dú ódè ná bà-tóo d'è
 girl COMP 3F leave CONJ father-3F NEG
 sē è ná bāyndí-ŋ
 INCEPT go CONJ man-DEF
 'The girl refused to go with her father and instead went with the man.'
 (lit. 'the girl [said] that she would not go with her father . . .')

The third person pronoun may not occur before the verb except to code logophoricity. The position before the verb results in an ungrammatical sentence if logophoricity is ruled out:

- (59) *ŋ̄-yàá ná dú bòy kójò kò-tó
 1SG-say COMP 3F break hoe GEN-3F
 'I said that she broke her hoe.'
- (60) *ŋ̄-yàá ná dí bòy kójò kè-i
 1SG-say COMP 3M break hoe GEN-3M
 'I said that he broke his hoe.'

The third person masculine logophoric pronoun is *ì* rather than *dí* and like the third feminine it precedes the verb; it is cliticized to the preceding complementizer, e.g.:

- (61) dàì lē gòl kāmā-ì sùbù tu né gò láy. wà
 3M also see wives-3M three all COP REL beautiful very
 nā-ì bēē-ì tāmá mání pínà d'è
 COMP-3M give.FUT-3M(DAT) wife ANAPH one NEG
 'He himself saw that all his three wives were very beautiful, and said that he would not give one of them to him.'

7 Reference system in the de dicto domain

The purpose of the present section is to demonstrate (1) that there exists a connection between logophoricity and hypothetical mood and (2) that languages make a systematic distinction between de re and dicto addressees (cf. Frajzyngier 1991). Taken together the two hypotheses indicate that one must also take into consideration, whether the

reference is in the domain de re or domain de dicto, as well as the syntactic and discourse domains of binding. The evidence for (1) is provided by the fact that in languages in which there exists a formal distinction between logophoric and nonlogophoric coding, the means deployed for logophoric reference are also deployed for the coding of hypothetical. The explanation for this fact is that if a reference is logophoric, it is to an entity that exists in the domain of discourse, not necessarily in the domain of reality. The hypothetical modality is never in the domain of reality. I illustrate the connection between the means of encoding logophoricity and hypothetical coding in two languages in which the means are formally different: Mupun and Lele.

7.1 Logophoricity and the hypothetical in Mupun

Although most of the logophoric pronouns in Mupun occur in the embedded clause when the main clause has a verb of saying, there are examples of sentences in which the main verb is not a verb of saying but that have logophoric pronouns in the embedded clause:

- (62) kat puun la reep nə mə cin ko d'un mbə sin
 when parent girl DEF 3PL do as 3PL.L FUT give
 la reep nə n-kenken kas
 girl DEF PREP-very fast NEG
 'If the parents of the girl act as if they will not give away the girl fast . . .'
- (63) kat la reep beer am kaa la mis fe la mis nə man nə
 if girl pour water on boy CONS boy DEF know COMP
 paa pə dem d'in mənə
 3F.L PREP like 3M.L then
 'If a girl pours water on the young man, then he knows that she loves him.'
 (Frajzyngier 1993:117)

In the two examples above, and in other similar ones, the main clause represents a hypothetical event. And the hypothetical event is treated as an event that belongs to the domain de dicto rather than de re; hence the participants are referred to through logophoric pronouns.

7.2 Logophoricity and the hypothetical in Lele

Coding of the third person plural subject on the verb through suffixation in Lele indicates a known, referential subject, e.g.:

- (64) han è-gé dàwù-gē ná kámdà sò
 when go-3PL gather-3PL CONJ women two
 'When they went it was a group with two wives.'

Third person plural is coded by the suffix *ge*. In the second verb in the sentence the subject marker is omitted, e.g.:

- (65) déená nòjú-tò kínyé sē òm'-gé tū gō bàl
 then relative-3F DEM-PL INCEPT catch-3PL goat REL castrated
 nè òb ná kārā
 HABIT ask ASSOC people
 'Then, her relatives caught a large castrated goat and challenged the people.'
- (66) dà 'túgú tóŋ nī kārā kòŋdirè kūsī-gē sùbù
 LOC village certain LOC people young men body-3PL three
 'In a village there were three young men.'
- (67) yā-gé nā
 say-3PL COMP
 'They said thus:'
- (68) è-gé cáani bāyndí-ŋ kàlò sè yír-ì
 go-3PL bush man-DEF snake got up bite-3M
 'When they went into the bush, a snake bit him.' (the man)

The presence of the two types of configuration in Lele allows the encoding of the indefinite human subject (Frajzyngier 1982), equivalent of English *they*, French *on*, German *man*, and Spanish third person plural coding on the verb. The coding of the hypothetical is achieved through the position of the third person plural pronoun *gē* before the verb, e.g.:

- (69) *dài* *h-āq* *bà* *nā* *gē* *bè-ì* *kùrmbàlò* *tāmá-ì*
 3M DEM CONTR COMP INDEF give-3M chief wife-3M
 bà *nā-ì* *wèl* *ná* *ūndō* *hà* *kúr* *nā* *wèl*
 CONJ COMP-3M sleep CONJ 3F till place COMP day
 nā *gē* *dìgr-ì* *ná* *kóló* *túmādū-ì* *ná* *d'árfínìq* *d'è*
 COMP INDEF kill-3M CONJ reason death-3M CONJ anger-3M NEG
 'The first one said that if he is given the chief's wife to sleep with till the
 daybreak, then he can be killed, because death does not worry him.'
- (70) *gē* *yà* *bè* *kùrmbàlò*
 INDEF tell BEN chief
 'The chief was informed.'
- (71) *gē* *dìgr-ì* *gē* *sò*
 INDEF kill-3PL two
 'Two were killed.'
- (72) *dài* *gō* *sùbù* *gē* *dìgrè-ì* *è* *wèl* *ná* *kùrmbàlò* *tāmá-ì*
 3M REL three INDEF kill:FUT-3M go sleep CONJ chief wife-3M
 'The third one, who was going to be killed, went to sleep with the chief's
 wife.'

The logophoric reference and the hypothetical are both elements of the *de dicto* domain (Frajzyngier 1991). Compared to the domain of reality, the *de dicto* domain has often fewer semantic distinctions. Thus if a language has a gender distinction in the domain of reality it might not have a gender distinction in the domain *de dicto*. This is the case in Polish and Lele, and it explains why in example (7) in Mupun, where instead of the biologically expected second person feminine, the narrator (who was a woman) used the second person masculine.

8 Implications

The proposed analyses reveal that the category pronoun has different binding properties across languages. These properties are in a complementary relationship with other coding means available in the language. The proposed analyses call for a taxonomy of pronouns based on their binding domains. Along with a taxonomy of pronouns we must have a taxonomy of other means of coding reference in the language. Case studies in the present paper suggest a taxonomy that contains the

following elements: pronouns that are bound within a sentence but not within a clause (logophoric pronouns); switch reference pronouns, which are bound by an antecedent in discourse but not by the immediately preceding antecedent (spoken, nonliterary Polish); and pronouns that may be bound either within the same sentence or by an immediately preceding antecedent in discourse (English).

Another major implication of the analyses is that what is commonly called 'agreement' is a coding means with a number of functions. One of these functions is the coding of coreference with the immediately preceding subject. But there are also split 'agreement' systems, in which some pronouns encode coreference and others encode switch reference.

In order to fully understand the binding of pronouns or lack thereof, one must take into consideration the semantic modalities encoded in the grammatical structure of the language. In the present paper only two modalities have been discussed, the *de dicto* and *de re* modality. But it is conceivable that some languages may have other distinctions.

References

- Broadwell, Aaron. (this volume). Binding Theory and Switch-Reference.
- Cantrall, William R. 1975. Favored structures and intonational limitations. *Papers from the parasession on functionalism*. Chicago: Chicago Linguistic Society. 36-46.
- Clements, George N. 1975. The logophoric pronoun in Ewe: Its role in discourse. *Journal of West African Languages* 10. 141-177.
- Cloarec-Heiss, France. 1969. *Les modalités personnelles dans quelques langues oubanguiennes. Discours direct-Discours indirect*. Paris: SELAF.
- Cooper, William E. 1976. Speech timing of coreference. *Proceedings of the 1st International conference on speech, acoustics, and signal processing*. Philadelphia: I.E.E.E.
- Dik, Simon. 1989. *The theory of functional grammar*. Dordrecht: Foris.
- Fiengo, Robert & Robert May. 1994. *Indices and identity*. Cambridge, Mass: The MIT Press.
- Fiengo, Robert & Robert May. 1995. Response to William's review of *Indices and identity*. *Language* 71. 794-801.
- Frajzyngier, Zygmunt. 1982. Indefinite agent, impersonal, and passive: A functional approach. *Lingua* 58. 267-290.
- Frajzyngier, Zygmunt. 1985. Logophoric systems in Chadic. *Journal of African Languages and Linguistics* 7. 23-37.
- Frajzyngier, Zygmunt. 1989. Three types of anaphora. In Isabelle Haik & Laurie Tuller (eds). *Current Progress in African Linguistics*. Dordrecht: Foris. 194-216.
- Frajzyngier, Zygmunt. 1991. The de dicto domain in language. In Elizabeth C. Traugott & Bernd Heine (eds). *Approaches to Grammaticalization*. Volume I. Amsterdam / Philadelphia: John Benjamins. 219-251.
- Frajzyngier, Zygmunt. 1993. *A Grammar of Mupun*. Berlin: Reimer.
- Frajzyngier, Zygmunt. 1996. *Grammaticalization of the Complex Sentence: A case study in Chadic*. Amsterdam & Philadelphia: John Benjamins. Complementary Series to Studies in Language.
- Frajzyngier, Zygmunt. in progress. A syntax of Lele.
- Hagège, Claude. 1974. Les pronoms logophoriques. *Bulletin de la Société de Linguistique de Paris* 69.1. 287-310.
- Haiman, John. 1983. On some origins of switch reference marking. In John Haiman & Pamela Munro (eds). *Switch reference and universal grammar*. Amsterdam/Philadelphia: John Benjamins. 105-128.
- Hyman, Larry M. & Bernard Comrie. 1981. Coreference and logophoricity in Gokana. *Studies in African Linguistics, Supplement* 8. 69-72.
- Kurcz, Ida, Andrzej Lewicki, Jadwiga Sambor, Krzysztof Szafran, & Jerzy Woronczak. 1990. *Słownik frekwencyjny polszczyzny współczesnej*. Cracow: Polska Akademia Nauk, Instytut Języka Polskiego.
- Meillet, Antoine. 1937. *Introduction à l'étude comparative des langues indo-européennes*. Paris: Hachette.

- Nitsch, Kazimierz. 1960. *Wybór polskich tekstów gwarowych*. 2nd ed. Warsaw: Państwowe Wydawnictwo Naukowe.
- van der Post, Laurence. 1986. *The lost world of the Kalahari*. San Diego: Harcourt Brace.
- Weibegué, Christophe. 1992. *Système phonologique du Lélé. Mémoire en vue de l'obtention de la Licence ès Lettres*. Université du Tchad.
- Weibegué, Christophe & Pierre Palayer. 1982. *Lexique Lele-Français*. Sarh: Centre d'études linguistiques.

List of abbreviations

ANAPH	Anaphor
COMP	Complementizer (morpheme)
A.CONJ	Counterexpectation conjunction
CONS	Consecutive
CONTR	Contrastive focus marker
FUT	Future
GEN	Genitive
II.	Hausa
INDEF	Indefinite human subject
INSTR	Instrumental
LLC	London-Lund (corpus)
LOG	Logophoric
NEG	Negative
PAST	Past tense
PL	Plural
PREP	Preposition
PRES	Present

Binding Theory on Minimalist Assumptions

Robert Freidin

The Minimalist Program proposed in Chomsky (1995) radically alters the foundations of syntactic theory by reformulating several fundamental theoretical constructs (e.g. involving phrase structure and transformations) as well as placing severe methodological restrictions on what tools and mechanisms might be employed in the construction of syntactic analyses. To a large extent, the reformulation of constructs is driven by methodological requirements - especially the assumption that all constructs must meet a criterion of conceptual necessity, the Ockham's razor of the Minimalist Program. This paper attempts to sketch the ramifications of this and other assumptions of the Minimalist Program as they apply to a theory of binding. In particular, the discussion will focus on the effects of minimalist assumptions on the standard version of Binding Theory within the Principles and Parameters framework (Chomsky 1981; Chomsky & Lasnik 1993; Freidin 1994). As in other areas of syntactic investigation, minimalist assumptions lead to a radical revision of the standard theory that has been in use for over a decade.

To begin, let us briefly review the standard theory in broad outline. It consists of the following three principles.¹

- (1) a An anaphor must be bound within a local domain.
- b A pronoun cannot be bound within a local domain.
- c An r-expression cannot be bound.

The relation *bound* is defined in terms of c-command and coindexation: one expression binds another if it c-commands the other and carries the same index. As formulated, the

¹ The usual formulation says that a pronoun must be free in a local domain and an r-expression must be free. Nothing of substance changes with the formulation given in (1) given that *free* means 'not bound'. Following standard practice, we will refer to principles (1a-c) as Principle A, B, and C respectively.

binding principles operate as output conditions (i.e. conditions on representations). Thus binding theory must specify to which level(s) of representation the binding principles apply. It must also define 'local domain' for Principles A and B. A subsidiary question arises as to whether this definition is the same for both principles (cf. Chomsky & Lasnik 1993) or different (cf. Freidin 1986). Furthermore, binding theory must account for the fact that the three principles appear to be instantiated somewhat differently crosslinguistically. In the case of Principles A and B this may be due to parametric variation affecting the definition of local domain (see Yang 1983, Freidin 1992). Even for Principle C there appears to be some crosslinguistic variation which involves distinguishing domains in which the principle applies from those in which it does not (see Lasnik 1991).

The minimalist assumption that theoretical constructs must meet a criterion of conceptual necessity has a profound effect on the binding theory sketched above. The prime example discussed in Chomsky (1993) concerns levels of representation. The conceptual argument is crystal clear. The interface levels of Phonetic Form (PF) and Logical Form (LF) are required to account for how the computational system of human language C_{HL} connects with other systems of the mind/brain involved in the production and perception of the physical signals of speech (including sign language) and in the translation of thought to language as well as language to thought. However, there is no such motivation for levels of D-structure and S-structure as characterized in previous work. Therefore, the postulation of such levels of representation is, under the Minimalist Program, illegitimate.² This creates an immediate problem for any version of binding theory that proposes the application of binding principles at either level.

Consider for example the empirical argument discussed in Chomsky (1993) that Principle C applies at S-structure. The argument is based on the following evidence [Chomsky's (23a-c)].

- (2) a You said he liked {the pictures that John took}.
 b [How many pictures that John took] did you say he liked *t* .
 c Who [*t* said he liked [α how many pictures that John took]].

² Although Chomsky allows that the empirical properties of language might force the postulation of constructs that depart from the criterion of conceptual necessity (1995:318, fn.7), the preference for conceptual arguments over empirical arguments, which lies at the heart of the Minimalist Program, renders this option extremely unlikely (see Freidin 1997).

In (2a), because *he* c-commands *John*, the pronoun cannot take the name as its antecedent. In contrast, the pronoun in (2b) does not c-command the name and therefore the name may be interpreted as its antecedent. While the interpretation of (2c) is straightforward (the pronoun cannot take the name as its antecedent), its analysis is not. (2c) contains two *wh*-phrases, only one of which has moved from its grammatical function position to create the required quantifier/variable structure. Given the prohibition against vacuous quantification, the second *wh*-phrase must also move covertly at LF to create a quantifier/variable structure. If the entire phrase α adjoins to *who*, then in the resulting structure the name and pronoun will be in the same relation as in (2b). Since the name in (2c) cannot be interpreted as the antecedent of the pronoun as it can in (2b), this demonstrates that Principle C cannot apply at LF. However, there is another LF analysis for (2c) that doesn't lead to this conclusion - namely, that only the quantifier *how many* gets fronted at LF. In this case the structural relation between the pronoun and the name remains at LF as we see it in (2c); hence there is no need to postulate a special level of S-structure at which Principle C can apply.

In the development of the Minimalist Program in chapter 4 of Chomsky (1995), this line of analysis is motivated on economy grounds. Basically, since what drives movement is feature checking, it is assumed that what is being moved is a set of formal features. Overt movement involves pied piping of categories, for reasons that are not entirely clear. However, if economy requires that operations be minimal, then covert movement should apply only to features. Thus the covert quantificational movement of *how many* at LF would involve only the features on the quantifier, and not the remainder of the phrase α . The criterion of conceptual necessity argues in favor of this analysis over the alternative that requires the postulation of S-structure. In pursuing it, we discover that the alternative involved an unmotivated assumption - namely, that covert movement must involve categories.

The elimination of D-structure and S-structure as levels of representation has a salutary effect for a theory of binding. Without these levels, there is no possibility that either the three binding principles could apply at different levels within a single language or one or more principles could apply at different levels in different languages. Neither possibility was precluded in earlier versions of binding theory. Therefore the fact that they do not arise would have to be established via empirical argument, which as we have seen may be subject to unwarranted assumptions. The optimal situation given the minimalist perspective is when empirical arguments support conceptual arguments.

Limiting the application of binding principles to LF representations appears to require the adoption of the copy theory of movement transformations. In (3), for example, the pronoun cannot take the name as antecedent even though it does not c-command the name.

(3) [How many pictures of Alice] did she really like *t*.

Assuming that Principle C is operative in such constructions, so that the antecedent relation in (3) is blocked for the same reason that it is blocked in (4), we are led to postulate an LF representation of (3) in which the pronoun c-commands the name.

(4) She really liked four pictures of Alice.

The copying theory of movement would give us (5), which presumably would be translated into an LF representation along the lines of (6).³

(5) [How many pictures of Alice] did she really like [how many pictures of Alice].

(6) [How many *x*] did she really like [*x* pictures of Alice].

Without this kind of LF derivation, (3) might easily be construed as evidence that Principle C applies at a level of D-structure.

It is worth noting here that given the copy theory of movement operations in conjunction with the kind of deletion required to derive (6) from (5), one could still maintain that Move Category (i.e. Move α) applies covertly in (2c) but that the required deletion provides the same result as the Move Feature analysis. Therefore examples like (2c) do not provide empirical evidence for the Move Feature analysis as we might have otherwise expected.

Although the copying analysis is required if binding principles apply only at LF, it raises a potentially difficult problem for examples like (2b) where the moved wh-phrase includes a relative clause. Thus compare (7) to (3).

(7) [How many pictures that Alice bought] did she really like *t*.

³ This follows the analysis of Chomsky & Lasnik (1993). Cf. their (105).

In (7) the name *Alice* may be construed as the antecedent of the pronoun, in contrast to (3) where it cannot. This requires that in the LF representation of (7), the relative clause does not show up in the position of the trace. Exactly how this to be achieved is not clear, nor is it clear exactly what LF representation of (7) would be. Under the copying analysis (7) could involve (8).

- (8) [How many pictures that Alice bought] did she really like [how many pictures that Alice bought].

The derivation of the LF representation for (7) would involve some deletions - presumably *pictures* in the moved phrase and the quantifier *how many* in the copy. If we treat (7) on a par with (3) then the relative clause would be deleted in the moved phrase as well - yielding the wrong structure since *Alice* may be interpreted as the antecedent of the pronoun. This shows that there is an apparent asymmetry in the behavior of relative clauses and complements with respect to binding principles (cf. Freidin 1986, 1992, 1994; Lebeaux 1988). How this is to be captured in an LF representation (7) seems problematic. Taking (6) as a model, (7) would presumably appear at LF as (9).

- (9) [How many *x* that Alice bought] did you say she really liked [*x* pictures].

The problem with (9) is that *x* is a variable ranging over integers whereas the relative clause modifies *pictures* not an integer.⁴

Rather than pursue this analysis further, let us consider a related set of facts that suggest that a Principle C analysis of these constructions is perhaps on the wrong track. If we substitute a copy of the name in (3) and (7) for the pronoun, we should presumably get the same results with respect to Principle C since it is the binding of the name that is at issue. Perhaps surprisingly, this turns out not to be the case.

- (10) [How many pictures of Alice] did Alice really like *t*.
 (11) [How many pictures that Alice bought] did Alice really like *t*.

⁴ Note that this problem arises even if we adopt a Lebeaux style analysis in which the relative clause is adjoined to the *wh*-phrase after it is moved so that the wrong binding configuration between the name and the pronoun never occurs.

In both (10) and (11) it is possible to interpret the two instances of the name *Alice* as referring to the same person. This is expected for (11) given that its LF representation is like that of (7) where the relative clause is not reconstructed in object position. The coreferential interpretation of (10) is, however, completely unexpected given that its LF representation would be parallel to that of (3) - i.e. (6), hence (12).

(12) [How many *x*] did Alice really like [*x* pictures of Alice].

Under the standard theory, the two names on the coreferential reading are in a binding relation which should be prohibited by Principle C. In (13) where no overt movement is involved this binding relation is prohibited.

(13) Alice really liked four pictures of Alice.

The natural interpretation of (13) requires that there be two people named Alice.

The contrast between (3) and (10) is unexplained and apparently unexplainable under the standard theory. Moreover, the standard theory makes the wrong prediction for the interpretation of (10). Separating the pronoun/name case from the name/name case along the lines of Lasnik (1991), where Principle C is split into several conditions depending on the status of the binder, one of which states that an *r*-expression is pronoun-free (i.e. cannot be bound by a pronoun), eliminates the problem of having a principle apply in one case but fail to apply in a structurally identical case. However, we are still left with a serious problem for the residue of Principle C since it predicts the wrong interpretation for (10).⁵

So far we have been discussing the application the standard binding theory, specifically Principle C, at LF because that is where it would have to apply given the minimalist assumption that the only two levels of representation are the interface levels PF and LF. It can't apply at PF given the further assumption that PF contains no structural information. "PF is a representation in universal phonetics, with no indication of syntactic elements or relations among them (X-bar structure, binding, government,

⁵ Another condition would prohibit an *r*-expression bound by another *r*-expression. As Lasnik shows, this condition is subject to parametric variation whereas the other is not. Note that the interpretation of (10) could be accounted for if the condition on pairs of *r*-expressions held at S-Structure rather than LF. On minimalist assumptions we would want to avoid this conclusion if possible. See below for discussion on excluding the condition on pairs of *r*-expressions from binding theory altogether.

etc.)" (Chomsky (1993:194)). Therefore, binding principles can only apply to LF representations. However, it is not clear that under minimalist assumptions the formulation of the binding principles in the standard theory is in fact conceptually motivated.

Consider first that fact that under the standard theory the definition of 'bound' involves two nominal expressions in a c-command relation that are coindexed. Under minimalist assumptions, however, indices and similar devices are not available. Chomsky takes it as a natural condition "that outputs consist of nothing beyond properties of items of the lexicon (lexical features); in other words, that the interface levels consist of nothing more than arrangements of lexical features" (Chomsky 1995:225), thereby meeting a condition of inclusiveness.⁶ Furthermore, he claims that:

"A theoretical apparatus that takes indices seriously as entities, allowing them to figure in operations (percolation, matching, etc.), is questionable on more general grounds. Indices are basically the expression of a relationship, not entities in their own right. They should be replaceable without loss by a structural account of the relation they annotate." (Chomsky 1993:fn.53)

Obviously if we eliminate indices as a grammatical device, then binding theory must be recast in some other way since the standard theory is to a large extent a theory about the assignment of indices.⁷

The alternative proposed in Chomsky & Lasnik (1993) (and adopted in Chomsky (1993)) involves replacing indexing procedures with interpretive procedures. As Chomsky & Lasnik note, the indexing procedures of the standard theory require interpretive procedures as well. By recasting the binding principles as interpretive procedures it is possible to dispense with the indexing procedures. Thus the binding

⁶ Although the footnote to this passage allows that violations of inclusiveness might be forced by empirical considerations, no indication is given as to what might actually count in that direction.

"Note that considerations of this nature can be invoked only within a fairly disciplined minimalist approach. Thus with sufficiently rich formal devices (say, set theory), counterparts to any object (nodes, bars, indices, etc.) can readily be constructed from features. There is no essential difference, then, between admitting new kinds of objects and allowing richer use of formal devices; we assume that these (basically equivalent) options are permitted only when forced by empirical properties of language." (1995:fn.7)

⁷ See for example the discussion of the standard theory in §1.4.2 of Chomsky & Lasnik (1993).

principles in (1) become the interpretive procedures of (14), where D stands for the relevant local domain in which the procedure applies.

- (14) a If α is an anaphor, interpret it as coreferential with a c-commanding phrase in D.
 b If α is a pronoun, interpret it as disjoint from every c-commanding phrase in D.
 c If α is an r-expression, interpret it as disjoint from every c-commanding phrase.

Under this proposal, the principles of binding are not conditions on representations. Rather, they assign certain interpretative relations among nominal expressions, and are thereby derivational in nature. Thus (14a) as an interpretive procedure does not account for cases where the interpretation cannot apply, e.g. (15).

- (15) a *Herself is clever.
 b *Mary thinks that herself is clever.
 c *Mary expects that John will like herself.
 d *Mary expects John to like herself.

That is, we need a further statement (16) to account for (15).

- (16) An anaphor must be interpreted as coreferential with an appropriate antecedent.

If (14a) is the only interpretive rule for anaphors, then the only possible antecedent will be a c-commanding phrase in D.⁸ In the case of (14b), we need no further condition to process the disjoint reference interpretation for pronouns. However, if (14b) is the only

⁸ While (16) is required to account for (15a-b), there is a way of interpreting (14a) so that (16) would not be required to account for (15c-d). If (14a) interprets the anaphor *herself* as coreferential with *John*, then the deviance of (15c-d) would come from the failure of agreement of gender features which the coreference relation would surely entail. In other words, (14a) simply marks some c-commanding nominal expression in D as the antecedent of the anaphor (in D). When (14a) fails to apply, as in (15a-b), the result is excluded by (16). This account treats both (15a) and (15b) in the same way. Cf. Chomsky & Lasnik (1993) where (15a) requires a different analysis from (15b) with respect to their interpretation of (14a).

rule of pronoun interpretation in binding theory, then C_{HL} does not account for the fact that sentences like (17) are ambiguous.

(17) Mary thinks that she is clever.

The pronoun and the name will not be interpreted as disjoint in reference by (14b), but that does not say whether they are coreferential or not. Thus we have returned in essence to Lasnik's 1976 theory of pronominal coreference where the coreference possibility in (17) is not given by any rule of grammar.

Principle C of the interpretive theory (14c) does not fare any better than the standard theory version (1c) with respect to (10). It makes the same wrong prediction with respect to (12), the putative LF representation of (10). Moreover, the existence of such a rule of interpretation (or alternatively a condition on representations like (1c)) ought to be suspect on conceptual grounds. While both anaphors and pronouns act as anaphoric expressions - i.e. they stand in for some other nominal expression, r-expressions do not. Thus it seems inappropriate for that reason to treat them as if they could behave as anaphoric expressions and therefore must be interpreted as disjoint from c-commanding nominals.⁹ If we restrict our attention to the issue of antecedents for anaphoric expressions, then Principle C would be restricted to covering just examples like (18).

⁹ Higginbotham (1983) proposes an alternative to standard binding theory which also precludes treating r-expressions as anaphoric in nature. His analysis is based on the claim that "the interpretation of an expression can be given in one and only one way" (his (26)), which is characterized as an informal condition. The basic idea is that an r-expression gets its interpretation from its lexical content and therefore cannot get an interpretation in another way - i.e. by Linking to an expression construed as an antecedent. As Lasnik & Uriagereka (1988) note, there are serious problems with this approach involving the interpretation of pronominal epithets, which have their own lexical interpretation internally and yet can be externally linked to an antecedent. Furthermore, as they also note, even anaphoric expressions (pronouns, reflexives, and reciprocals) have specific interpretations based on inherent lexical features (i.e. ϕ -features) and therefore legitimate linking configurations would apparently constitute a violation of this informal condition.

Reinhart (1986:146) proposes to replace Principle C with a pair of pragmatic strategies, one for speakers and another for hearers. The speaker's strategy is to employ bound anaphora when the structure being used allows it and coreference is intended, unless the speaker has some reason to avoid bound anaphora. The hearer's strategy is to assume that if the speaker avoids the bound anaphora option available for the structure, then coreference was not intended, unless the hearer knows the speaker had reasons for avoiding bound anaphora. Thus the structure (1.a) satisfies the pragmatic conditions.

- (18) a He likes Max.
 b He thinks that Max is clever.

If so, then Principle C might be reformulated as the interpretive rule (19).

- (19) If α is a pronoun, then interpret it as disjoint from every r-expression it c-commands.

(19) is equivalent to the Lasnik (1991) principle that r-expressions be pronoun-free, but without reference to 'bound r-expressions', which I am suggesting should be illegitimate on conceptual grounds. With the elimination of indexing, the issue of coreference between r-expressions should disappear. Presumably there is no need for a special grammatical mechanism to check pairs of r-expressions to determine whether they corefer or not.

At this point we still have no account for the fact that when two r-expressions are phonetically identical, there exists an interpretive option to treat them as having the same reference - which does not entail that one is anaphoric on the other.¹⁰ In some cases this option is realized (e.g. (10) and (11) above), in others it is prohibited (e.g. (13)). The fact that the difference depends on whether a c-command relation holds between the two r-expressions is suggestive that binding theory is somehow really involved, even though it is unclear how this could be achieved if binding theory is limited solely to anaphoric relations within sentences, where one expression stands in

whereas (i.b-c) both fail. (Coindexing indicates bound anaphora, italics indicates intended coreference, and # marks pragmatic inappropriateness).

- (i) a John_i read his_i book.
 b #*He* read *John's* book.
 c #*John* read *John's* book.

One problem with this alternative is that it does not distinguish between (i.b) and (i.c), and therefore cannot account for the fact that while intended coreference between the pronoun and the name is precluded in (3), intended coreference is possible when the name is substituted for the pronoun as in (10). For further critical comments on pragmatic accounts of binding, see Lasnik & Uriagereka (1988:166,fn.12).

¹⁰ Note too that we have no account of the facts in Lasnik (1991) which suggest that a condition on the coreference possibility for pairs of r-expressions is subject to parametric variation.

for another (its antecedent).¹¹ The same reference option for r-expressions is an entirely different type of phenomenon, involving the assignment of reference to r-expressions which is presumably not part of C_{HL} . Anaphoric relations, in contrast, concern the assignment of antecedents to anaphoric expressions (bound anaphors, pronouns, and pronominal epithets), a purely grammatical phenomenon. R-expressions involve word/world relations, while anaphoric expressions involve word/word relations. Thus on conceptual grounds alone it seems natural to separate the two cases.

The picture of binding theory on minimalist assumptions that is beginning to emerge seems very different from the standard theory. Instead of three conditions on indexing representations involving anaphors, pronouns, and r-expressions, we have three rules of interpretation - one for anaphors and two for pronouns - that involve the relations between anaphoric expressions and their antecedents. Furthermore, the rule for an anaphor specifies when a nominal can be interpreted as its antecedent, while the rules for a pronoun specify when a nominal expression cannot be its antecedent. The rule for anaphors can fail to apply or apply improperly, yielding deviant structures. The rules for pronouns cannot because the only relation C_{HL} specifies for a pronoun is disjoint reference and a pronoun, unlike an anaphor, does not require an antecedent in the sentence in which it occurs.

Recasting the principles of binding theory as rules of interpretation instead of conditions on representations avoids a potentially serious problem with respect to the minimalist assumption that all output conditions are external interface conditions (bare output conditions). First, unless parametric variation extends to bare output conditions (a totally unmotivated assumption at this point), it would be difficult to explain crosslinguistic variation for binding configurations documented in the literature (cf. chapters 7 and 8 of Freidin 1992 and Yang 1983). Moreover, it is far from clear how standard violations of Principles B and C could be construed in any real sense as violations of Full Interpretation (FI), the only candidate we presently have for a bare output condition (see Freidin 1997). With bound anaphors, however, it is possible to construe the failure of the interpretive rule (e.g. (15a-b)) as resulting in a violation of FI, if we can assume that an anaphor without an antecedent is assigned no referential interpretation. If the reference of nominal expressions is assigned outside of C_{HL} , then

¹¹ The interpretive rule (14c) which would accomplish this seems in this regard a holdover from the standard theory in which coindexing allowed us to treat r-expressions as if they could have an anaphoric interpretation.

FI will apply externally to C_{HL} as well. This indicates that FI must operate as a bare output condition, since the failure to assign a referential interpretation occurs outside C_{HL} .

At the conclusion of his survey of the history of modern binding theory (1989), Howard Lasnik writes:

“...the developments explored here can best be seen not as a series of revolutionary upheavals in the study of anaphora, but rather the successive refinement of one basic approach, and one that has proven remarkably resilient. Given that BT has become the subject of intensive investigation, with new phenomena in previously unexplored languages being constantly brought to bear, and all this while old problems from familiar languages remain, further refinements, or even revolutionary upheavals, are inevitable.” (Lasnik 1989:34)

From the preceding discussion of binding theory on minimalist assumptions it would seem that although some revolutionary upheaval may still be off in the future, the ground is certainly shifting so that our perspective appears to be undergoing a significant change.

References:

- Chomsky, Noam. 1981. *Lectures on government and binding*. Dordrecht: Foris.
- Chomsky, Noam. 1993. A minimalist program for linguistic theory. In Kenneth Hale and Samuel Jay Keyser (eds) *The view from building 20*. Cambridge, MA: The MIT Press. 1-52. [reprinted in Chomsky 1995]
- Chomsky, Noam. 1995. *The minimalist program*. Cambridge, MA: The MIT Press.
- Chomsky, Noam & Howard Lasnik. 1993. The theory of principles and parameters. In Joachim Jacobs, Arnim von Stechow, Wolfgang Stemefeld & Theo Vennemann (eds). *Syntax: an international handbook of contemporary research*, vol. 1. Berlin: Walter de Gruyter. 506-596. [reprinted in Chomsky (1995)]
- Freidin, Robert. 1986. Fundamental issues in the theory of binding. In Barbara Lust (ed.) *Studies in the acquisition of anaphora*, vol. 1. Dordrecht: Reidel. 151-188.
- Freidin, Robert. 1992. *Foundations of generative syntax*. Cambridge, MA: The MIT Press.
- Freidin, Robert. 1994. Generative grammar: Principles and parameters framework. In R.E. Asher (ed.) *The Encyclopedia of Language and Linguistics*, vol. 3. London: Pergamon Press. 1370-1385.
- Freidin, Robert. 1997. review article of Chomsky (1995). *Language* 73. 571-582.
- Higginbotham, James. 1983. Logical form, binding, and nominals. *Linguistic Inquiry* 14. 395-420.
- Lasnik, Howard. 1976. Remarks on coreference. *Linguistic Analysis* 2. 1-22. [reprinted in Lasnik (1989)]
- Lasnik, Howard. 1989. *Essays on anaphora*. Dordrecht: Kluwer.
- Lasnik, Howard. 1991. On the necessity of binding conditions. In Robert Freidin (ed.) *Principles and parameters in comparative grammar*. Cambridge, MA: The MIT Press. 7-28. [reprinted in Lasnik 1989]
- Lasnik, Howard & Juan Uriagereka. 1988. *A course in GB syntax*. Cambridge, MA: The MIT Press.
- Lebeaux, David. 1988. Language acquisition and the form of grammar. Doctoral dissertation. University of Massachusetts, Amherst.
- Reinhart, Tanya. 1986. Center and periphery in the grammar of anaphora. In Barbara Lust (ed.) *Studies in the acquisition of anaphora* vol. 1.. Dordrecht: Reidel. 123-150.
- Yang, Dong Whee. 1983. The extended binding theory of anaphors. *Language Research* 19. 169-192.

A Configurational Approach to Thematic Binding

Jeffrey S. Gruber

1 Introduction*

In this article, we describe a configurational syntactic theory of thematic linking and show that it provides a unifying account of anaphora and other forms of binding.

Thematic linking is the association of the participants, or thematic roles, of an event or situation with the syntactic arguments of a predicate that expresses it (see e.g., Baker 1988, Carter 1988; Gruber 1996b, Jackendoff 1990, Pesetsky 1995). For example, sentences may express a simple 'Locational' relation between two participants, as in (1a,b): one element of the event is located in relation to another. These are called the 'Theme' (labeled Θ) and the 'Location' (labeled Λ), respectively. However, (1a) and (1b) differ in linking: in (a), the Theme is linked with the subject and the Location with an oblique argument, while in (b) the Location is linked with the subject and the Theme with a direct object.

- (1) a the ball (Θ) lies in the box (Λ)
b the box (Λ) contains the ball (Θ)

A configurational theory of thematic linking (Gruber 1994, 1996a,b, 1997) maintains that all thematic roles are determined purely configurationally in a syntactic structure. As stated in (2), it further maintains that that structure is represented within the syntactic component of grammar.

* This work was supported by the Social Sciences and Humanities Research Council of Canada grant no. 411-92-0012 ('La Modularité de la Grammaire: Arguments, Projections, et Variations') and Fonds Institutionnels de Recherche (University of Quebec at Montreal) to Anna-Maria Di Sciullo.

(2) *Strict Thematic Configurationality in Syntax*

Every thematic relational distinction is distinctively represented configurationally in syntax.

It is hypothesized that all thematic roles, or θ -roles, are determined configurationally in base-generated syntactic positions. In particular, as illustrated in (3), an expression (XP or YP) is interpreted as Location in the specifier position of a lexical verb phrase VP, and Theme in the complement position. Some reasons for this arrangement are given below (see also references above). All other θ -roles, such as Source, Goal, Accompaniment, Agent, or Patient, are based on this primitive relation.

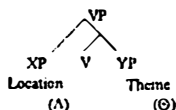
(3) *Locational relation*

We likewise assume a configurational theory of Case (cf. Bittner & Hale 1994), in which all elements bearing θ -roles must acquire Case by movement into configurationally distinguished Case positions (Pollock 1989, Chomsky 1991). Case positions determine argument types, so that this movement constitutes argument projection. It also provides the linking between θ -roles and arguments. For example, in (1b) the element bearing the Location role moves to subject position while the one bearing the Theme role moves to object position. Movement from a basic position to a Case position forms an Argument-Chain (A-Chain), the relation between these positions being that of an anaphor and its antecedent (Chomsky 1986a,b). Thematic linking is therefore a relation of anaphoric binding, and θ -role 'assignment' involves ' θ -binding', as in Williams (1989). Unlike Williams however, all anaphoric binding must involve identification from a Case position.

Of particular relevance to binding is θ -role 'colinking', where more than one θ -role is linked to a single argument. It always involves referential identification of θ -roles from distinct subevents, each consisting of its own set of θ -roles. As shown in the paraphrases in (4), a SMASH event is analyzed as consisting of HIT and BREAK subevents, of which HIT has explicit roles of Theme (Θ) and Goal (Γ) while BREAK has the explicit role of Theme (Θ). The Theme of BREAK is colinked with the Theme of HIT in the subject in (4a), and with the Goal of HIT in the object in (4b).

- (4) a the stone smashed against the wall
 (the stone (Θ) hit the wall (Γ) and the stone (Θ) broke)
 b the stone smashed the wall
 (the stone (Θ) hit the wall (Γ) and the wall (Θ) broke)

We hypothesize that θ -role colinking results from the properties of a form of conjunction that relates subevents in a complex event with a sense of sequence or consequence (Gruber & Collins 1997). This is schematized in (5) for the sentences in (4). The conjunction phrase CjP interpreted as the event SMASH is asymmetric, consisting of specifier and complement, interpreted, respectively, as precedent subevent HIT and consequent subevent BREAK, themselves possibly complex verbal structures |VP|.

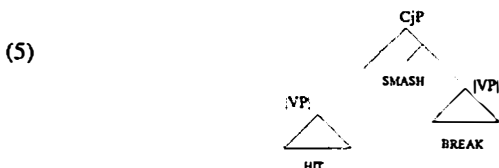

The conjunction phrase has the property that θ -role-bearing elements from each subevent must be referentially identified. This occurs in the course of their movement for Case, effectively integrating their A-Chains. Hence they acquire Case in the same position and are colinked in a single argument.

Just as the Chain integrative property of sequential conjunction leads to colinking, a similar property of distributive conjunction, as in (6a), accounts for referential identification in binding in general (6b-d).

- (6) a A, B, and C each hit a tree
 b each particle hit the other
 c the particles touched each other
 d the rope touched itself

Distributive conjunction thus provides for both antecedent-anaphor A(argument)-binding relations (6c,d), and operator-variable (nonargument) A'-binding relations (6a,b). Differences in binding type depend on the stage at which a distributive conjunction phrase occurs in a derivation. In A-binding, distributive conjunction is

derivationally prior to the achievement of a Case position by the binding element. In A'-binding, it is derivationally later.

Derivations demonstrating the Case- θ relation for thematically simple sentences are shown in section 2. Section 3 shows this for thematically complex sentences with colinking, involving the integrative property of conjunction phrases. In section 4 we discuss the relation between distributive conjunction and binding. In section 5 the formal mechanisms necessitated in colinking are extended to account for distributive predications and anaphora. Reciprocal distributives and independent-argument anaphora are treated in section 6, and valency-reducing anaphora in section 7.

2 The Case- θ relation and binding

In this section we show for thematically simple sentences how derivations involving the Case- θ binding relation works, and discuss further ramifications of this relation. Derivations of sentences expressing simple Locational events, such as (1a,b) are given in (7a,b). The thematic VP is specified for a conceptual field or dimension over which thematic relations generalize, here a dimension of physical Position PST. Three configurationally distinguished functional positions extend the VP, corresponding to the three Case/argument (or agreement) types, subject, object, and oblique, labeled AgrS, AgrO, or AgrK.

(7) a

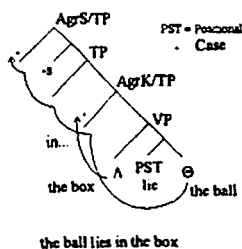

b

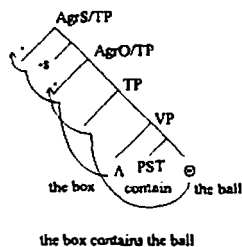

Derivations are from bottom to top (Chomsky 1995), from the composition of a thematic verb phrase VP, to its functional extension followed by movement. Thematic and functional heads move to conflate into a single predicate. θ -role elements (Location Λ and Theme Θ) compete for argument positions. The latter seek to optimize Chain formation (Gruber 1994), either by reaching a structural Case position of maximal number of links or a semantic Case position of one link, marked '.' in (7). The links are subject to a 'minimal link condition' (Chomsky 1993, 1995), meaning effectively that elements may hop over at most one specifier position, producing a 'leap-frog' movement.

Uniform functional extension (Grimshaw 1991, Demuth & Gruber 1995) is essential. Case positions always extend a position with referential properties TP, the highest in (7) being that for finite tense. Each TP in turn may be an extension of a lexical phrase, the lowest being the thematic VP. We leave open as to whether Agr or T are full phrasal or multiple specifier extensions (Chomsky 1995). To simplify tree structures, however, separate specifiers or phrasal projections for T and Agr are not shown (AgrS/TP = AgrSP extending TP, etc.). Nevertheless, the sequence is always followed:

(8)

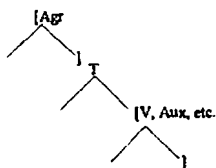

T(P) is always active, and must be moved into. The Case function of Agr is present only where argument projection is optimal. The presence of precisely three TP positions in a Locational predication is essential. This accounts for linking asymmetries. Thus we have the argument patterns in (7), but cannot derive a simple Locational predication with Location as object (9a) or Theme as oblique argument (9b).

(9) a

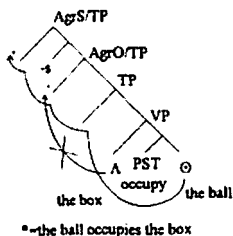

b

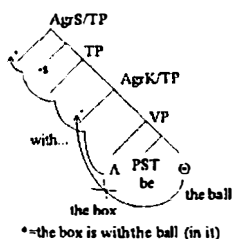

These derivations violate the minimal link condition, and are excluded. *Occupy* does not exemplify (9a), but means roughly 'the ball is in the box, filling it', where the object is also a Theme. *With* does not exemplify (9b), but is a small clause complementizer.

The prediction of this asymmetry shows that Location must be the specifier and Theme the complement of the thematic phrase. Given the sequence of functional extension, the opposite configuration would predict the opposite asymmetry: Location as object and Theme as oblique.

It is conjectured that movement into a Case position is necessary only for referentially specific arguments. A nonspecific nominal does not itself move for Case. Rather a formal part of it does, determiner features [D] (Chomsky 1995). This part is referentially specific, and can appear in the Case position as an expletive. The nonspecific nominal then appears in a lower position, as in Dutch (cf. Koster 1994, Zwart 1993). For example, a specific Theme (Θ) (*de bal*) projected as subject or object (10ai,ii) is above an assertive or negative particle (*wel/niet*). In contrast, a nonspecific Theme (*een bal*) is below the particle (*wel/g-*) (10b). The particle itself is below the Case position of the expletive element [D]—*er* in subject (bi) and ϕ (null) in object position (bii) (Gruber & Jaspers 1994).

- (10) a i dat (*wel/*niet) de bal (wel/niet) in de doos (en) ligt
that (*so/*not) the ball (Θ) (so/not) in the box lies
ii dat die doos (*niet (NO FOCUS)) de bal (niet) (en) bevat
that the box (*not) the ball (Θ) (not) contains
- b i dat er (wel/g-) een bal (?wel/niet) in de doos (en) ligt
that there (so/not) a ball (Θ) (?so/not) in the box lies
ii dat die doos ϕ (wel/g-) een bal bevat
that the box ϕ (so/not) a ball (Θ) contains

That Case is necessary only for referentially specific θ -role-bearing elements suggests that Case is the licensing of argumenthood by this interpretation. Taking referential specificness to mean referential distinctness in some domain leads to the hypothesis, akin to the True Binariness Principle of Seuren (1989) and the Disjoint Agreement Principle of Pica (1994), Pica & Snyder (1995), that arguments in this domain have disjoint reference. This essentially asserts principle B of the Binding Theory (Chomsky 1986b): pronominals, in fact all arguments are basically disjoint in reference in this domain. Anaphora or the referential identification of θ -role elements will be attained only by their projection as a single argument, i.e. their achievement of Case in the same position, or 'colinking'. This conception will be explored in subsequent sections.

The domain of disjoint reference is defined thematically, rather than predicatively. It is that of a single thematic function, less than a θ -domain or the complete functional complex (1986a) of Chomsky's Binding Theory. A thematic function is either Locational, comprising the roles of Theme (Θ) and Location (Λ), as in (1), or 'Motional', illustrated in (11), comprising the roles of Theme (Θ), Source (Σ), Goal (Γ) and possibly Accompaniment and Path.

- (11) the ball (Θ) rolled from the bush (Σ) to the tree (Γ)

A pronominal must not bear a θ -role of the same thematic function as a θ -role of its antecedent; i.e. it must be 'cofunctionally free' (Gruber 1990). Thus a pronominal cannot appear, as in (12a), bearing an Accompaniment role (AC) whose antecedent is of the same 'Positional' Motional function. It can however appear, as in (12b), bearing an Accompaniment role whose antecedent is simply Agent (AG), which is of a distinct 'Causational' function. But a pronoun cannot appear expressing Goal (12c) if the subject Agent is colinked with Source cofunctional with Goal. Subjects and objects are cofunctional, bearing Agent and Patient (PT) roles both of a Causational function, and so pronominal objects are not cofunctionally free (12d). Anaphors can of course occur in all these instances to express coreference, licensed by a kind of colinking of argument positions (sections 5-7).

- (12) a *John slid the rope, (Θ) beside it, (AC)
 b John, (AG) slid the rope beside him, (AC)
 c *John, (AG, Σ) threw the boomerang to him, (Γ)
 d *John, (AG) slid him, (PT, Θ) beside the cart

That the domain of disjoint reference is defined in terms of basic θ -role positions means that they represent the very objects of reference in event structure. Distinct, and hence specific, reference is the relation of an element in a logical expression, i.e. in a Case or argument position, with elements in the representation of an event, i.e. with basic θ -role positions. We may say that Case is the achievement of a relation of distinct reference for a set of colinked θ -roles. If any of the θ -roles 'referred to' by a pair of distinct arguments are in the same thematic function, the arguments, i.e. their sets of θ -roles, will necessarily be disjoint in reference.¹

3 Thematic structure and obligatory thematic colinking

In this section we show the derivation of thematically complex sentences involving θ -role colinking, and propose the derivational mechanism of colinking.

Colinking of θ -roles in a single argument, as exemplified in (4a,b), is evident throughout the event structure of sentences. It is also obligatory: θ -roles of subevents joined in an event structure must be colinked. It is sometimes explicit, as in 'object sharing' in serial verb constructions (13).

- (13) òkúta gbá ògiri fú (Yoruba)
 stone hit wall break
 (the stone (Θ) hit the wall (Γ) and the wall (Θ) broke)
 'the stone smashed the wall'²

In (4) and (13) the subevents are Motional thematic functions in a relation of consequence, forming a resultative predication. These are ordered iconically in (13), with the precedent subevent head preceding the consequent one. Normally any role of the precedent subevent is colinked only with just the Theme of the consequent

¹ What is relevant is the set of θ -roles achieving Case in an argument. A raised or ECM argument must in this context be said to achieve Case, hence reference, for itself and the clause out of which it arises. The latter would be cofunctional with the subject of the main clause, with which a raised/ECM pronominal is therefore referentially disjoint. A nonraised argument achieves Case independently and so is cofunctionally free with the subject of the main clause. I have benefited from discussion with Chris Tancredi.

² (13) is in fact ambiguous and can have the meaning of Theme-Theme colinking 'the stone smashed against the wall'.

subevent.³ Colinking of precedent Goal or Theme with consequent Theme is illustrated in (4) and (13). Colinking of Source (Σ) with Theme is illustrated in (14).

- (14) the jar spilled empty of jam
 (jam (Θ) spilled out of the jar (Σ) and the jar (Θ) became empty)

At a deeper level of event structure, a Motional predication is analyzed as two Locational subfunctions in a relation of temporal sequence, as in (15a). The precedent Location (Λ) is configurationally the Source (Σ) while the consequent Location (Λ) is Goal (Γ). These are also represented by separate verbs in a serial verb construction (15b), again ordered iconically. In a Motional predication the Themes, and only the Themes, of each Locational subpredication are obligatorily colinked.

- (15) a the ball rolled from the tree into the road
 (the ball (Θ) at the tree ($\Lambda=\Gamma$) precedes the ball (Θ) in the road ($\Lambda=\Sigma$))
 b bòdù ti ibi igi yí sí ojù ònà
 ball go.from place tree roll go.to top road

The iconic ordering in (13) and (15b) is a property of asymmetric conjunction expressing event sequences (16a), but not nonsequential conjunction (16b). (16a/bi) shows that obligatory colinking is also a property of just such conjunctions: the subject of the second clause must be null and identified with that of the first.

- (16) a i John_i hit the wall and (*he_i) broke it
 ii *John broke the wall and hit it
 b i John_i ate the rice and (he_i/Mary) drank the milk
 ii Mary_i drank the milk and (she_i/Bill) ate the rice

We hypothesize that conjunction forms the basis for combining subevents with obligatory colinking generally. Subpredications are combined in the specifier and complement of an asymmetric conjunction phrase expressing sequence or consequence. Thematic 'atoms' of each of these subevents must then be colinked, i.e. projected as a single argument.

³ An exception may be the Goal in a double object construction, which appears to be the 'affected object' (Tenny 1989) and therefore colinked with the precedent Patient role (see Jackendoff 1990).

(17) shows the derivation of Motional predications. These consist of two Locational subevent representations combined through an asymmetric conjunction phrase expressing temporal sequence CjP-TMP. Each Locational subevent has the roles of Theme and Location, but in the precedent subevent, in the specifier of CjP-TMP, the Location is configurationally determined as Source (Σ), while in the consequent one, in the complement of CjP-TMP, Location is Goal (Γ). The two Themes (Θ) are necessarily colinked. The conceptual dimensions of the combined Locational subevents are also necessarily identical, PST (Positional) for the *go* predication (17a), and CTT (Contact) for the *hit* predication (17b).

Note that the configurational determination of Source and Goal implies that one cannot exist without the other. They may be implicit however. In (17a) for a verb like *go*, both are explicitly projected semantically (in AgrKPs), while in (17b) for a verb like *hit*, the Source is implicit ($[\Sigma]$ in brackets) and the Goal is projected explicitly as direct object (in AgrOP).

The principle of uniform functional extension is reflected in precisely two TP positions extending each thematic VP and CjP, with a third, for finite tense (AgrS/TP) extending the matrix CjP only. This is again necessary to account for linking patterns.⁴

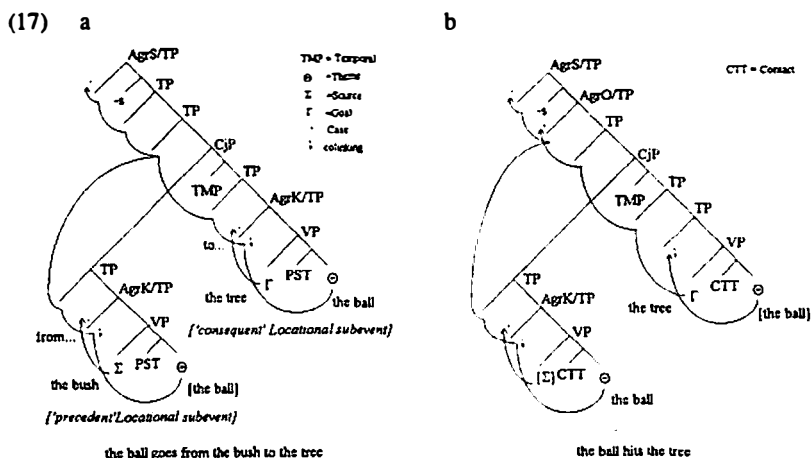

We hypothesize that the θ -role elements determined as colinked are those moving through the specifier of the lowest TP in the functional extension of each conjoined

⁴ See note 6.

subevent representation, labeled ';' in (17). As can be seen by the exclusion of (9b), the first move of any Theme element must always be to this position, TP-VP (the TP immediately dominating VP), in the extension of the thematic VP.⁵ The Themes of Locational subevents in both (17a) and (17b) are thus colinked. Given that elements in TP-VP are identified, their movement constitutes a single Chain and therefore they do not necessarily both move to a Case position. They move across-the-board, for example, only in (17a), where Source and Goal are projected semantically in the lowest position. In (17b) only the precedent Theme moves to the Case position, that of subject AgrSP. The consequent Theme is prevented from moving beyond its colinking position by the movement of the Goal to a higher position for structural Case, that of object in AgrOP.⁶

Configurally similar colinking positions are involved in the derivation of a resultative predication (18) in which Goal and Theme are colinked. The derivation consists of two Motional subevent representations combined through an asymmetric conjunction phrase expressing consequence CjP-CSQ.

Thus there is colinking on two levels. The precedent Motional subevent is one of Contact (CTT), like that of *hit*, the Themes of its component Locational subevents colinked by moving into the lowest TP extending them, TP-VP-CTTs, labeled ';'. The consequent Motional subevent is one of change-of-State (STE), like *break*, its Themes colinked in the similar positions TP-VP-STE. The Goal of the STE subevent is explicitly expressed by *apart*, semantically (inherently) Case-marked in AgrKP.

⁵ The notation α - β refers to the α immediately above (locally dominating or commanding) β .

⁶ Movement for Case out of the highest active specifier position in the specifier of CjP is presumed to be permissible in virtue of its being 'L-marked' (Chomsky 1986a). Movement across this position is impermissible however, perhaps by conditions on the direction of concomitant head-movement (Chomsky 1993, 1995). The derivation of simple Motional predications is thus sharply constrained to just three possibilities: the two in (17) with subject Theme and either oblique or direct object Goal, and a third with Source subject and Theme object ('the tree drops fruit'), constituting an important linking asymmetry (Gruber 1994, 1996a,b, 1997).

(18)

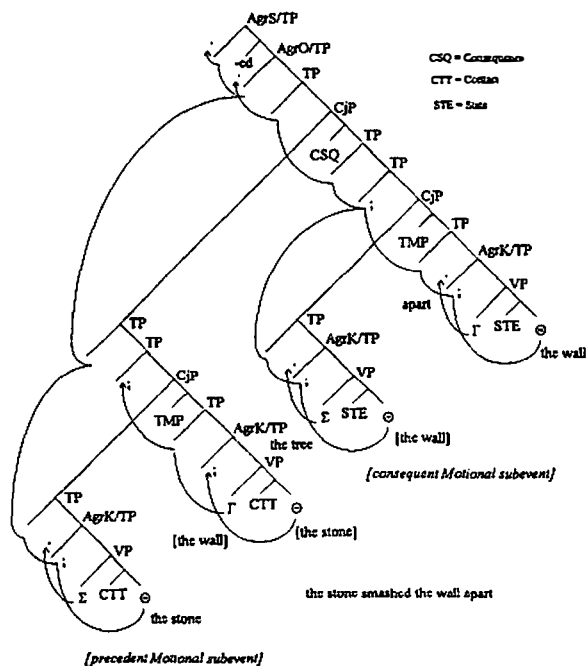

On the higher level the colinking positions are again the lowest TPs in the functional extension of the conjoined subevents. These are now the Motional subevents headed by Cj-TMP, with colinking positions TP-CjP-TMP. In (18) the Theme(s) (Θ) of the STE Motional subevent move (across-the-board) into the consequent TP-CjP-TMP above each VP-STE. In the CTT Motional subevent however it is the Goal (Γ) which moves into the precedent TP-CjP-TMP above each VP-CTT. Goal of the CTT subevent is thus colinked with Theme of the STE subevent.

Note that among these colinked θ -role elements only the Theme of the STE subevent moves to a Case position, AgrOP, the CTT Goal remaining in its colinking position while the CTT Theme moves to the subject Case position. As stated, θ -role elements identified by colinking constitute a single Chain, and must achieve Case in one position, either by across-the-board movement or movement of only one of the elements.⁷

⁷ The derivation of resultatives with Theme-Theme colinking, e.g. (4a), and Source-Theme colinking, e.g. (14), are similar, involving only modification of movements for Case originating in the precedent Motional subevent.

Let us call the element that moves into the colinking positions TP-VP/CjP the 'thematic topic' of the subevent representation it extends. Obligatory colinking is then the identification of thematic topics to form coherent event structures, requiring subevents to be about the same entity. It is a functional property of the superordinate CjP that combines the subevents. We would then expect it to be licensed in the superordinate CjP, or its functional extension, TP-CjP-TMP for Motional predicates and TP-CjP-CSQ for resultatives. This however cannot be by movement of thematic topics into the superordinate TP-CjP, since across-the-board movement cannot always occur. Rather it must be by movement of functional heads into T-CjP (the head of TP-CjP). Identification in colinking positions is then the interpretation of the adjunction structure formed by functional heads arising from these positions and conflating into the superordinate T-CjP. In particular, we propose that obligatory thematic colinking results from a property of CjP to reduce head-adjunction structure under an interpretation of identity.

Observe that under CjP-TMP there is, besides colinking, another condition of identity between conceptual dimensions. For example, each of the VPs in the Motional predication in (17a) is Positional, VP-PST, while in (17b) they are of a Contact dimension, VP-CTT. Suppose that at any T-CjP-TMP the head-adjunction structure conflating into it must be reduced in conceptual dimension specifications under a condition of identity. The complement adjunction structure first moves into T-CjP-TMP; only part of the adjunction structure from the specifier then subsequently adjoins or adds to this structure, some of it being eliminated under interpretation of identity with corresponding parts from the complement. Thus, the conceptual dimension specification of the VP in the specifier of CjP-TMP, e.g. VP-PST in (17a), would be eliminated under interpretation of identity with that in the complement of CjP-TMP. Given that this reduction must occur, both VPs under CjP-TMP will have identical conceptual dimension specifications, as observed.

By the operation of this mechanism in obligatory colinking, we can derive the generalization that the consequent colinked role is always the Theme. Given the positions determining colinking, in a Motional predication like (17a,b), only the Themes of each Locational subpredication can be colinked, since, as noted, the Themes must always first move into TP-VP. In a resultative predication, as in (18), the precedent colinked role is the role of whatever element moves into the precedent TP-CjP-TMP. This is Goal in (18), but it could also be Theme or Source, as exemplified in (13a) and (14). The role with which it is colinked however is always the Theme. Suppose each T-VP/CjP has a 'topic' feature checked with the element, the 'thematic topic', that has moved into its specifier. Each T-VP/CjP incorporates

into the head adjunction structure and moves to the T-CjP above it. There they are reduced to one under interpretation of identity of their checked topics. Since movement from the specifier follows movement from the complement, it is always the adjunction structure out of the specifier of CjP, the precedent subevent, that is reduced, while that out of the complement, the consequent subevent, persists. Therefore the consequent colinked role is always determined as the Theme of the most consequent subevent in the deepest complement of CjP.

In this way asymmetric conjunction has Chain integrative properties. 'Identification' through reduction at CjP essentially means integration of the A-Chains of θ -role elements in subordinate thematic topic positions, so that they achieve Case in the same position, and are projected as a single argument. The Case- θ binding relation then implies that they are coreferential. The Case-position binds as an argument (A-binds) the set of colinked basic θ -role positions, each of which is an anaphor. Chain integration with concomitant colinking is thus derivational in character. The event of deletion in the relevant structures induces the interpretation of referential identity in derivationally related structures.⁸ In the following sections we extend the account of obligatory thematic colinking to anaphora in general and other kinds of binding.

4 **Distributive predications**

The involvement of a conjunction phrase in determining an anaphoric relation between θ -role positions is also evident in distributive conjunction, plurality and reciprocal and reflexive anaphora. There are clear lexical relationships among these forms indicating thematic, and hence configurational, similarity. Consider the paradigms in (19) and (20).

⁸ This derivational mechanism of reduction in conjunctions with across-the-board effects contrasts with the representational 'cofactoring' procedure of Williams (1978).

- | | |
|---|---|
| <p>(19) <i>Goal anaphors</i></p> <p>a.i each of A, B, and C hit a tree
/A, B, and C each hit a tree</p> <p>.ii each of the stones hit a tree
/the stones each hit a tree</p> <p>b.i each of A, B, and C hit the other
.ii each particle touched/hit the other</p> <p>c.i A, B, and C touched/hit each other
.ii the particles touched each other
.iii the dust touched itself/*each other
.iv the rope touched itself/* each other</p> <p>d.i A, B, and C coalesced (with each other/*themselves) /... collide, gather, mix, merge, converge, come together
.ii the particles coalesced (with each other/?themselves)
.iii the sand coalesced (with itself/*each other) /...condense, compress, collapse, fuse together
.iv the stone coalesced (?with itself/*each other</p> | <p>(20) <i>Source anaphors</i></p> <p>a.i each of A, B, and C slid away from a tree
/A, B, and C each slid away from a tree</p> <p>.ii each of the stones slid away from a tree
/the stones each slid away from a tree</p> <p>b.i each of A, B, and C slid away from the other
.ii each particle separated/spun away from the other</p> <p>c.i A, B, and C separated/slid away from each other
.ii the particles spun away from each other
.iii the dust blew away from itself/*each other
.iv the rope stretched away from itself/* each other</p> <p>d.i A, B, and C dissociated (from each other/*themselves) /...separate, scatter, spread out, disperse, come apart
.ii the particles dissociated (from each other/?themselves)
.iii the sand dissociated (from itself/*each other) /...disintegrate, break apart
.iv the stone dissociated (?from itself/*each other)</p> |
|---|---|

(19/20a,b) illustrate distributive operators (or 'bound variable anaphora'), while (19/20c,d) show coreferential anaphora, with antecedents varying in the manifestation of number (i-iv). The ordinary distributive predications in (a) have either a conjoint (a.i) or plural (a.ii) subject. If unique meaning is associated with derivational configurations, distributive quantification with plurals must be derivationally similar to distributive conjunction. The reciprocal operator *each...the other* in (b) would also be derivationally similar, since besides using the quantifier *each*, it has a distributive sense and occurs with plural or conjoint subject. These in a fundamental way must be similar to reciprocal anaphors (c.i,ii), which in turn must be similar to reflexive anaphors (c.iii,iv): whether the reciprocal (*each other*) or reflexive (*itself*) appears depends on whether the antecedent is plural (either morphological or conjoint) or singular (either uncountable or countable). The paradigm in (d) is similar to that in (c), but involves items which are lexically specified for anaphora as part of their particular meaning. That a single lexical item covers a range of types is evidence for the derivational similarity of those types.

The unifying factor among these types is the integrative function of distributive conjunction. This is relatively overt in the examples of (19/20) with conjoint or plural operators or antecedents. In the case of uncountable or countable singular antecedents

in the anaphoric relations (19/20c/d.iii,iv), the integration must involve θ -role-bearing elements that denote parts of that denoted by the lexical item serving as antecedent. They are spelled-out as a single argument, as indeed is the case in obligatory thematic colinking. Thus anaphoric relations involve thematic sub-argumental 'atoms' and processes that are derivationally 'pre-argumental', before the achievement of Case or 'argumenthood' by θ -role elements.

Distributive operators, like operators in general, however, involve movement derivationally subsequent to achieving Case. Thus a distinguished formative (*each*) is associated with the binder only in operator relations (19/20a,b), reflecting the operator property needed to drive movement after argument projection. Operator relations cannot involve sub-argumental atomicity, excluding singular operator binders (21a). Also, a reciprocal operator is impossible with a verb (*gather*, *scatter*) or particle (*together*, *apart*) lexically specified as anaphoric (21b).

- (21) a i *each rice stuck to a place in the pot (\neq each grain of rice)
 ii *each rice stuck to the other
 b i *the particles each gathered/rolled together with the other
 ii *the particles each scattered/spun apart from the other

The distinction between operator and anaphoric binding relations then depends on whether the distributive conjunction phrase is above or below the agreement phrase in which the binding constituent is projected. Subsequent sections will explore this conception in the derivation of binding relations.

5 Distributive operators and anaphora

Distributive predications necessarily include a referentially nonspecific constituent (underlined in (22)) that is token distinguished, but type identified, in each of its implied multiple instances. If such a constituent is absent (b) it must be inferred. In a collective predication, however, (c) there is no such requirement, and any constituent may be interpreted as constant in reference relative to instances of the subject.

- (22) a the boys were each by a/*the tree
 b the boys were each by the tree (at a different time)
 c the boys were both by the/a tree

The token-distinguished nonspecific element in a distributive predication is a bound position, with the integrated (subject) position its binder: each distinct token in the set named by the subject is associated with a distinct token of the set or type named by the nonspecific element.

We hypothesize that distributive predications involve a distributive conjunction phrase CjP-DST, with the property of requiring integration of elements from two positions simultaneously in each of a set of conjoined subpredications. This is accomplished by the movement of elements into the functional extension of CjP-DST. The elements achieving Case in the higher position move as a phrase and form the binding constituent; the elements achieving Case in a lower position move beyond that position as a clitic and form the bound constituent.⁹

As observed, a nonspecific constituent does not itself move for Case but rather an inner expletive element raising out of it does (section 2). In the distributive predications of (22a), this occurs in each subpredication conjoined by CjP-DST. Each nonspecific constituent is a distinct argument position and so token-distinguished. The integration of expletive elements then occurs simultaneously with the integration of elements from a higher position in each subpredication, forming the bound and binding constituents. Distributive conjunction thus relates, via the expletives, a token-distinguished element with each element of the binding constituent.

We assume the expletive element in distributive predication has the property of an anaphor or bound-variable requiring interpretation in a distributive conjunction phrase CjP-DST (i.e. in its functional extension) as related to some binder element. As in obligatory thematic colinking, the interpretation is effected through reduction of structure.

In accordance with this conception, the expletive element [D] encliticizes after it achieves Case, adjoining to the verbal head structure, ultimately to be licensed by reduction in T(P)-CjP-DST. Derivations are shown in (23) for distributive predicates of the type in (22a) expressing simple Locational relations (see 7a,b). Integrating binder elements move across-the-board into TP-CjP-DST, while clitic elements from the token-distinguished bound position move to T-CjP-DST. Integration occurs in TP-CjP-DST, which is therefore also the position of binding, marked ':'. This position is above the point (AgrSP) where the antecedent binder, here subject, achieves Case. Hence it is reached by (nonargument) A'-movement (dotted lines): the antecedent binder must be an operator and the movement 'operator-driven'.

⁹ Chomsky (1993) seeks a similar account for anaphora as movement of a clitic, arguing for a relationally interpretive account of coreference rather than one using referential indices.

(23) a. each A is by a B

b. each B contains an A

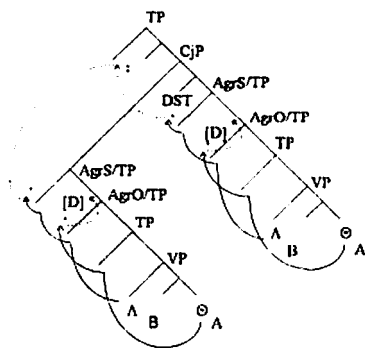
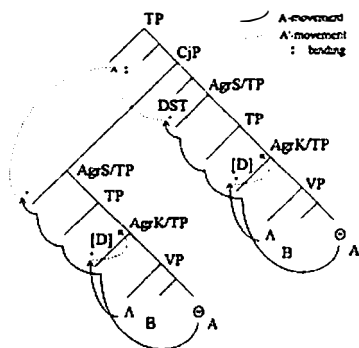

If conjunction phrases are involved in operator-variable relations generally, their necessary nesting predict island and crossover constraints. Thus the barring of the distributive interpretation in (24a) with respect to 'a dog' is parallel to the *wh*-island effects in (b).

- (24) a i John and Bill each like the woman who bought a dog
 ii John and Bill each wondered whether Mary saw a dog
 b i *who do they like the woman who saw *t*
 ii *who did they wonder whether/how Mary saw *t*

We also predict the bijection principle (Koopman & Sportiche 1982), covering examples like (25), that every variable is bound by one nearest quantifier/operator, and every quantifier/operator is the nearest binder for one and only one variable. If a variable is the position of an element that has moved to a Cj for integration under identification, then the isomorphism and locality necessarily holds, since everything except what is integrated in Cj must be token-identical.¹⁰

- (25) a ?*who_i does his_i mother love *t*, (weak crossover)
 b ?*his_i mother loves everyone_i,

¹⁰ Similarly, problems of reciprocity treated by Heim, Lasnik & May (1991) seem to be immediately explicable by the application of distributive conjunction licensing anaphoric relations at distinguishable positions in the derivation.

Reciprocals can be either operator-variable A'-binding relations (19/20b) or antecedent-anaphor A-binding relations (19/20c). A-binding (26a.i), but not A'-binding (26a.ii), must be within a complete θ -domain or functional complex, while the latter is constrained by island effects (26b.ii).

- (26) a i *they said that Mary saw each other
 ii they each said that Mary saw the other
 b i *the men like the woman who spoke to each other.
 ii *the men each like the woman who spoke to the other

Distributive predications, like reciprocals, can also be of either the operator or anaphoric type. Thus, besides the operator type of distributive predication above, with *each* syntactically associated with the antecedent (27a.i = 19a), we have the anaphoric type (27b.i) with *each* syntactically associated with the nonspecific constituent.

- (27) a i each of the stones hit a tree
 ii each of the men saw the stone hit a tree
 b i the stones hit a tree each
 ii *the men saw the stone hit a tree each

(b.ii) is unacceptable because the subject and anaphor must be within a single θ -domain, typical of A-binding, while in (a.ii) there is no such constraint, indicating A'-binding between operator and variable.

(28) shows 'argument-driven' anaphoric distributive predication, in contrast with operator-driven (23).

(28) a the As are by a B each

b the Bs contain an A each

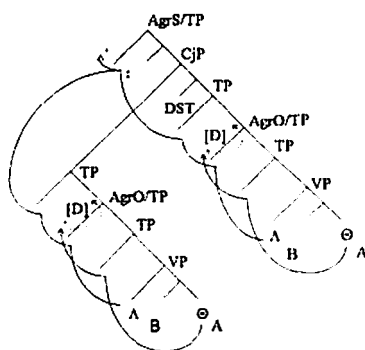
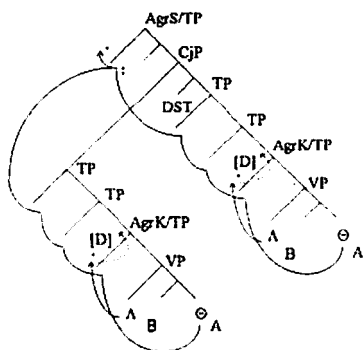

Here movement is only Case- or argument-driven since Case is achieved by the subject antecedent above the integration position TP-CjP-DST. Because CjP-DST immediately dominates the highest 'Tense' TP position, it carries the properties of this position and assigns nominative Case in the AgrP extending it, effectively AgrSP.

We can now see how in argument-driven distributive predication the relation between antecedent and bound element must be constrained to a θ -domain or complete functional complex, thereby deriving the essentials of principle A of the Binding Theory (Chomsky 1986b). A θ -domain is the domain in which arguments of a thematic event complex are projected, which includes the domain of conflation or incorporation of thematic and asymmetric conjunction heads into an adjunction structure. The anaphoric relation will naturally be contained within a θ -domain if the clitic element moves only as one of the elements of the thematic head adjunction structure that includes its projection position. It can then move only to a Cj in the domain of head conflation and hence can license only an antecedent originating in that domain, i.e. at or below the highest argument position (subject) in its θ -domain. In contrast, in the operator relation the clitic element must move independently of the head adjunction structure. Hence it may 'climb' to a Cj above the highest argument position in its θ -domain. The domain of operator binding is therefore not so constrained.

Distributive conjunction, or plurality, morphologically marked on or by the predication, has the property of being restricted to θ -domains, hence argument-driven. As observed by Frajzyngier (1985), it associates plurality only with Patient (= Theme) antecedents, serving as objects or subjects of intransitives. Examples are found in \neq Hòā (Gruber 1975) in the form of a regular prefix to predicates (*kí-*) and in lexically specific forms:¹¹

- (29) a i //kà'a-sì 'a kì /'ón-qà za b i /'a
 thing be P tree-PL side 'seat one'
 'the thing is by the trees'
- ii //kà'a-/kà'a 'a kì /'ón-qà kí-za ii /'é-//kà
 things be P tree-PL DST-side 'seat many'
 'the things are by a tree each'

The thematic restrictions on morphological distributive predications follow if the distributive conjunction phrase is predication internal, extending the second TP

¹¹ A Khoisan language in Botswana.

position, as in (30). This blocks any θ -role element except Theme from moving into CjP-DST. Thus a distributive predication would be possible for an elemental Theme-subject intransitive (30a), but not a Location-subject transitive (b).

(30) a

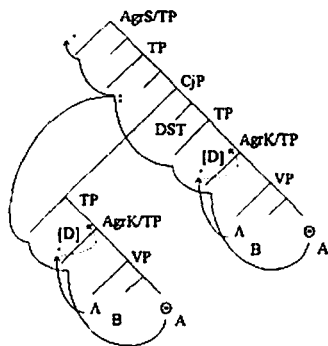

b

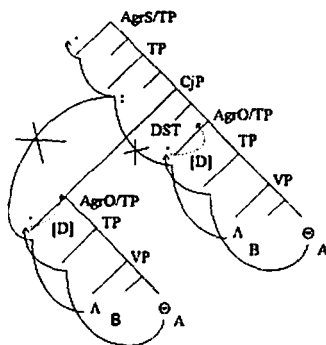

6 Reciprocals and independent-argument anaphora

A simple extension of the analysis of operator- and Case- or argument-driven distributive conjunction provides an account for the A'-binding relation in reciprocal distributives (*each...the other*) and the A-binding relation in reciprocal and reflexive anaphora (*each other*, *it/him/herself*), (19/20b) and (c) respectively. Independent-argument anaphors, such as the English pronoun type, do not affect valency, in contrast with valency-reducing anaphors such as the French clitic *se*, considered in section 7.

In ordinary distributive conjunction, the element in the bound position remains distinct in type from the integrated binder element. However, in reciprocal distributive conjunction, the element in the bound position, signaled by *other*, while still token-distinguished, is type-identified with the binder element. The moving clitic part with anaphoric properties must then include the type-identifying features of the argument in the bound position.¹² Features of this part, [D,PI], move to T-CjP where integration of the antecedent into a set of individuals occurs with reductive type-identification of the bound position with the binder.

¹² These might be identified as the plural partitive nominal in a construction that denotes a set of individuals (e.g. in 'a flock of birds').

The operator-driven reciprocal form is derived by A'-movement (31), the distributive conjunction phrase being above the projection position of the operator binder. Argument-driven anaphoric reciprocals are derived, as in (32), by A-movement in which the distributive conjunction phrase is below the position of argument projection of the antecedent binder.

- (31) a each A is by the other
(of the set of As)

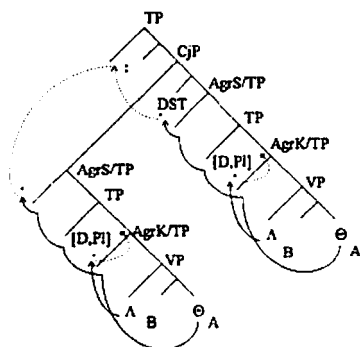

- b each B contains the other
(of the set of Bs)

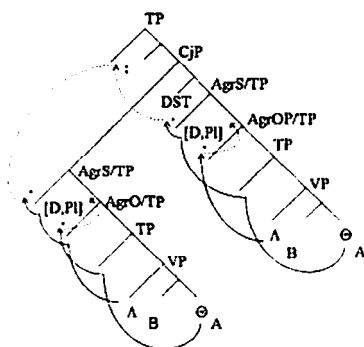

- (32) a the As are by each other
(of the set of As)

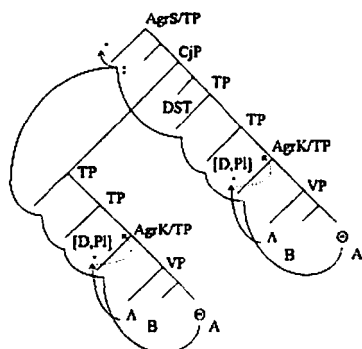

- b the Bs contain each other
(of the set of Bs)

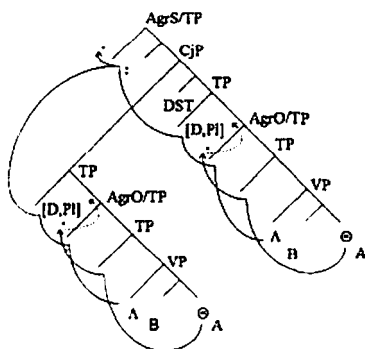

The clitic element [D,Pl] in (31/32) exorporates from the bound position, the projection position of the token-distinguished element, since, as referentially distinct, that part must achieve Case independently.

As noted in connection with examples (19/20c/d), reflexive anaphora is like reciprocal anaphora, except that the antecedent integrates into a singular nominal. Its

clitic elements must then carry features $[D, Sg]$ such that they relate to the antecedent elements as a single BODY/SELF whose parts are integrated in T-CjP-DST.¹³ The sense is that parts of SELF interact with other parts of SELF. This accords with the observation of Pica (1994) that reflexive anaphora involves only a part of the whole denoted by an argument, another part remaining disjoint in reference.¹⁴ Reflexive independent-argument anaphora is then derived as in (33):

- (33) a A lies beside itself (a part of A lies beside another part of A) b B contains itself (a part of B contains another part of B)

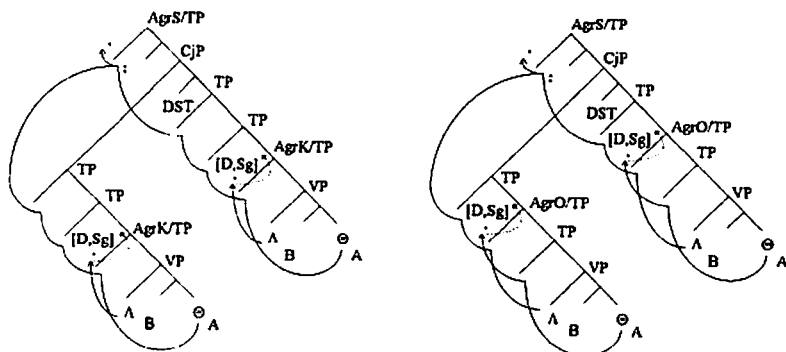

7 Valency-reducing anaphora

Thematic colinking (section 3) is, in a sense, valency reducing, inasmuch as elements of each subpredication are integrated in a conjunction phrase and projected as a single argument. Independent argument anaphors, such as English *each other* and *it/him/herself*, do not reduce valency despite such integration of θ -role-bearing elements, because, like simple distributive predications, only a part of the θ -role-bearing element in the bound position encliticizes. That part moves with the

¹³ Languages commonly have only one anaphor for both reflexives and reciprocals, in which case its clitic part would be characterized as simply $[D]$, together with an indication of its integrative properties. Its form may be that of a reflexive, as in the case of the French clitic *se* (section 7), so that in lexical spell-out the reflexive seems to be the default category, hence to be underspecified as just $[D]$. This accords with only Pl. and not Sg, as a specifier category (Gruber 1976).

¹⁴ Seuren (1989) accommodates disjoint reference (denotation) amongst arguments in a single predication by claiming that all reflexives are in essence valency-reducing. The claim here is that independent-argument reflexives are possible because the bound position of the reflexive is token-distinguished from the antecedent.

thematic head to be licensed and identified by the conjunction phrase; however, its erstwhile Case- or argument-position, a position of disjoint reference, remains.

As observed by Pica (1994), independent-argument anaphors are typically bimorphemic, reflecting these distinct functional parts. Monomorphemic anaphoric clitics, such as French *se*, are commonly valency-reducing. For example the reflexive of an erstwhile transitive verb, as in (35) becomes syntactically intransitive with a single argument, as shown by auxiliary selection of BE in the perfect.

- (34) Jean s' est photographié (Kayne 1992)
 J. self be photographed
 'John has photographed himself'

Valency-reducing anaphoric relations are similar to obligatory thematic colinking, licensing the achievement of Case by an entire argument element in the same place as another, hence leaving its erstwhile argument, i.e. Case, position inert, reducing valency. That is, an entire argument encliticizes to be integrated with another argument through a distributive conjunction head. (35) shows such a derivation for a generalized erstwhile transitive sentence. As would usually be the case, the thematic structure is complex, headed by some CjP-TMP/CSQ conjoining thematic VPs.

(35)

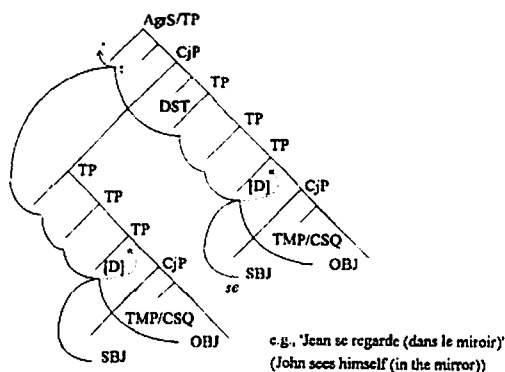

We have seen that for obligatory thematic colinking the interpretation of integration as a single Chain occurs by reduction and Chain integration at TP-CjP-TMP/CSQ. If an entire argument is an anaphoric clitic then it will not need to move to an independent argument position and 'excorporate' into the thematic head-adjunction structure. Instead, as shown in (35), the Chain integration point of thematic colinking at TP-CjP-TMP/CSQ provides a position for excorporation. It then moves with the

thematic head-adjunction structure to T-CjP-DST to be licensed and integrated with the antecedent elements.

This valency-reducing property follows directly from the integrative property of the clitic and Cj-DST. The internal logical object OBJ, driven for Case, moves into TP-CjP. The internal logical subject SBJ is also driven to move for Case. If it required independent Case it could not be licensed by moving into TP-CjP, but would move independently to subject position AgrSP. However, as an anaphoric clitic with integrative properties, it can, and must, move to T-CjP, whereby it will achieve Case through Chain integration or colinking with the object, also in TP-CjP. We assume the clitic moves as a phrase to TP-CjP and adjoins as a head to T-CjP whereby integration through reduction occurs. The integrated Chain then moves to the subject position as the single argument of an intransitive verb. Valency reducing anaphora thus differs from that of independent-argument anaphora primarily in the position at which the bound element enters the thematic head-adjunction structure.

Note that it must be the erstwhile subject, not the object, that is the anaphoric clitic, since otherwise the erstwhile subject could not move to TP-CjP. If the object had the anaphoric clitic property and not the subject, although the object would be driven to move into TP-CjP for Case, and could in principle satisfy its integrative property there, the subject would not be able to achieve Case by doing so, since it has no integrative property that can be satisfied there. Moreover, since the integrative property of the object would then not be satisfied the derivation will crash. As in the case of obligatory thematic colinking, the identified eliminated element arises from the specifier, i.e. the subject.

Thus derivational considerations relative to the configurations involved necessitate what has been observed for Romance clitics in Kayne (1992), drawing on Bouchard (1984), etc.: the element in subject position in valency-reducing clitic constructions is the erstwhile object, while the colinked element with anaphoric properties is the erstwhile subject. Standard evidence that this is so is the fact that *en*-cliticization out of a quantifier phrase can only come from an internal object position. Since *se* can cooccur with *en*-cliticization (36), the *en* arising out of the object implies that *se* arises out of the subject.

- (36) *il s' en est lavé beaucoup*
 there self of:them is washed many
 'many of them have washed themselves'

We can see that valency-reducing anaphora, unlike independent-argument anaphora, would be limited to direct or structurally Case-marked arguments, excluding semantically Case-marked arguments, since only a structural argument could pass through TP-CjP-TMP/CSQ. In French the clitic anaphor seems constrained to structural arguments. For semantically Case-marked oblique arguments the periphrastic *lui même* (himself), etc., must be used.

It would also be predicted that valency-reducing anaphora could not occur with transitive verbs that express simple Locational relations, since these involve no CjP-TMP/CSQ, necessary to provide a subChain termination point for the clitic to excorporate without constituting an independent argument. This may account for the impossibility of the use of *se* with certain verbs in French that seem to be of this minimal sort, as observed by Pica & Snyder (in press) in such examples as (37).

- (37) a *Jean se connaît
 'John knows (is acquainted with) himself'
 b Jean connaît Marie
 'John (Λ) knows Mary (Θ)'

The elemental structure with Location subject and object Theme is suggested by the paraphrase 'be acquainted with', in which *with* often indicates the Theme role. The use of a valency-reducing anaphor is excluded because there is no CjP in the event structure of such verbs by which it can be interpreted.

References

- Baker, Mark. C. 1988. *Incorporation: A Theory of Grammatical Function Changing*. Chicago: The University of Chicago Press.
- Bitner, Maria & Kenneth Hale 1994. The structural determination of Case. Manuscript. Rutgers University and Massachusetts Institute of Technology.
- Bouchard, Daniel. 1984. On the content of empty categories. Dissertation. Cambridge Mass.: Massachusetts Institute of Technology.
- Carter, Richard. 1988. *On Linking: Papers by Richard Carter*. Beth Levin & Carol Tenny (eds). Cambridge, Mass.: Center for Cognitive Science Lexicon Project, MIT.
- Chomsky, Noam. 1986a. *Knowledge of Language: Its Nature, Origins and Use*. New York: Praeger.
- Chomsky, Noam. 1986b. *Barriers*. Cambridge, Mass.: MIT Press.
- Chomsky, Noam. 1991. Some notes on economy of derivation and representation. In Robert Freidin (ed.) *Principles and parameters in comparative grammar*. Cambridge, Mass.: MIT Press. 417-54.
- Chomsky, Noam. 1993. A minimalist program for linguistic theory. In Kenneth Hale & Samuel Jay Keyser (eds) *The view from Building 20: Essays in linguistics in honor of Sylvain Bromberger*. Cambridge, Mass.: MIT Press. 1-52.
- Chomsky, Noam. 1995. *The minimalist program*. Cambridge, Mass.: MIT Press.
- Demuth, Katherine & Jeffrey S. Gruber. 1995. Constraining XP sequences. In Victor Manfredi & K. Reynolds (eds) *Niger-Congo syntax and semantics 6*. Boston: Boston University African Studies Centre. 1-30.
- Frajzyngier, Zygmunt. 1985. Ergativity, number, and agreement. Berkeley Ca.: Proceedings of the Eleventh Annual Meeting of the Berkeley Linguistics Society.
- Grimshaw, Jane. 1991. Extended projection. Manuscript. Waltham, Mass.: Brandeis University.
- Gruber, Jeffrey S. 1975. Plural predications in \neq Hôâ. In A. Traill (ed.) *Bushman and Hottentot Linguistic Studies*. Johannesburg, South Africa: African Studies Institute [Communication 2]. 1-50.
- Gruber, Jeffrey S. 1976. *Lexical structures in syntax and semantics*. Amsterdam: North-Holland.
- Gruber, Jeffrey S. 1990. Complex Θ -Structures. Manuscript. Cambridge, Mass.: MIT Lexicon Project seminar.
- Gruber, Jeffrey S. 1994. Principles of a configurational Theta Theory. *A festschrift for Dong-Whae Yang: Explorations in generative grammar*. Seoul, Korea: Hankuk Publishing Co. 69-111.
- Gruber, Jeffrey S. 1996a. Configurational Theta Theory. Manuscript. University of Quebec at Montreal.
- Gruber, Jeffrey S. 1996b. Configurational accounts of thematic linking regularities: The possessional-spatial asymmetry. In Anna-Maria Di Sciullo (ed.) *Configurations*. Ithaca, N.Y.: Cornell Cascadilla Press.
- Gruber, Jeffrey S. 1997. Modularity in a configurational theta theory. In Anna-Maria Di Sciullo (ed.) *Projections and interfaces: Essays on modularity*. Oxford: Oxford University Press.
- Gruber, Jeffrey S. & Chris Collins. 1997. Argument projection, thematic configurationality and Case theory. In Anna-Maria Di Sciullo (ed.) *Projections and interfaces: Essays on modularity*. Oxford: Oxford University Press.
- Heim, Irene, Howard Lasnik & Robert May. 1991. Reciprocity and Plurality. *Linguistic Inquiry* 22. 63-101.

- Jackendoff, Ray. 1972. *Semantic Interpretation in generative grammar*. Cambridge, Mass.: MIT Press.
- Jackendoff, Ray. 1990. *Semantic Structures*. Cambridge, Mass.: MIT Press.
- Kayne, Richard S. 1992. Anaphors as Pronouns. Manuscript. Cambridge, Mass.: MIT.
- Koopman, Hilda & Dominique Sportiche. 1982. Variables and the Bijection Principle. *The Linguistic Review* 2. 139-60.
- Pesetsky, David. 1995. *Zero syntax*. Cambridge, Mass.: MIT Press.
- Pica, Pierre. 1994. On the disjoint agreement principle. Manuscript. University of Quebec at Montreal and CNRS.
- Pica, Pierre & William Snyder. 1995. Weak crossover, scope, and agreement in a Minimalist Framework. *Proceedings of the 13th West Coast Conference on Formal Linguistics*. Cambridge, UK: Cambridge University Press.
- Pica, Pierre & William Snyder. 1997. On the syntax and semantics of local anaphors. In Anna-Maria Di Sciullo(ed.) *Projections and interfaces: Essays on modularity*. Oxford: Oxford University Press.
- Pollock, Jean-Yves. 1989. Verb movement, universal grammar, and the structure of IP. *Linguistic Inquiry* 20. 365-424.
- Seuren, Pieter A.M. 1989. Notes on reflexivity. In F.J. Hetvaert & F. Steurs (eds) *Worlds behind Words*. Leuven University Press.
- Tenny, Carol. 1989. The aspectual interface hypothesis. *Lexicon Project working papers* 31. Cambridge Mass.: Center for Cognitive Sciences MIT.
- Williams, Edwin. 1978. Across-the-Board rule application. *Linguistic Inquiry* 9. 31-43.
- Williams, Edwin. 1989. The anaphoric nature of θ -roles. *Linguistic Inquiry* 20. 425-456.

A Plea for Implicit Anaphora

James Higginbotham

1 Introduction*

The subject matter of binding theory has in recent years been transformed. This theory was originally concerned with the syntactic distribution and the semantic interpretation of the reflexive and reciprocal anaphora of English, and the distribution of anaphoric pronominals, these constituting the 'atoms' of anaphora in the sense of the conference to which a preliminary version of this article was presented. The anaphoric forms are observed to be at least very nearly in complementary distribution with ordinary pronominal anaphora, a fact that calls for explanation. Binding theory assumed a greater importance following the theoretical proposal that NP-trace is an anaphor, a proposal that was underwritten by the thesis that NP-trace could not occur in a position from which anaphora were excluded, and pronominals permitted; and also following the interpretation of PRO in Chomsky (1981) as a species of 'anaphoric pronominal.' Chomsky (1981) and other work assumed that linguistic structures represented anaphoric dependence explicitly by coindexing, so that the syntactic aspect of binding theory consisted in the conditions, both language-particular and universal, on the distribution of indices that could be assigned to anaphors and antecedents in syntactic structures.

All of the above elements of binding theory have been superseded or challenged in work of the last ten years or so, and the available data, both syntactic and semantic, have expanded in several directions. In this article, attending especially to Williams (1994), but also to other work as described below, I consider and promote a further expansion of binding theory, which I believe will preserve it nevertheless as a unified

* Material from which this article is excerpted was presented at the Leiden Workshop, and later at the LF Reading Group, MIT, at the University of Arizona, and at the University of Oxford. I am grateful to the audiences for comments and suggestions, and to Mario Montalbetti and Andrew Barss for substantial discussion. I am also indebted to Robert Fiengo and to the editors for extensive comments.

module of syntactic and semantic study. Under the expansion, binding theory is allowed to relate, either as anaphor or as antecedent, open positions in θ -grids, which I here call *implicit anaphora*.

Implicit anaphora contrast with *explicit anaphora*, relating linguistic formatives (including empty categories), and also with *mixed anaphora*, wherein one element is a linguistic formative, and the other a θ -position. For a simple example of how control might be understood as implicit anaphora, consider (1):

- (1) John tried [PRO to go to London].

In binding theory as restricted to relations between formatives, the obligatory anaphoric relation between PRO and the matrix subject was established by coindexing these expressions, or as in Higginbotham (1983) by linking the anaphor, PRO, to its antecedent, *John*. The semantics interprets the anaphoric relation as inheritance of reference by PRO of the reference of the subject, and so gives the cross-reference that is explicit in (2):

- (2) For $x=John$, x tried [$\wedge x$ go to London]¹

We can conceive instead, however, that an anaphoric relation is established, as part of the syntax, between the external θ -position of the embedded clause and the external θ -position of the V *try*, so that the cross-referential aspect of interpretation is fixed independently of lexical insertion. Then the formatives need not be linked or coindexed, but the effect on interpretation is as before. The possibilities for lexical insertion will be influenced, and in the case of the PRO of (1) determined, by the anaphoric relation independently established.

The basis for anaphora just conjectured for (1) applies to cases where there are no formatives at all to bear the anaphoric relations in question. Perhaps the simplest examples, discussed further in section 3 below, are those of *anaphor-incorporation*, as in (3):

- (3) self-starting (motor)

¹ I use the carat \wedge for intensional abstraction. Notice that the semantics shown requires PRO to be taken *de re*; for discussion see Higginbotham (1989a) and references cited there.

In (3) the *V start* θ -marks neither an internal nor an external argument; nevertheless, the argument positions may stand in an anaphoric relation, since a self-starting motor, on one interpretation, is a motor *x* such that *x* starts *x*. In another reading, (3) will apply truly to a motor *x* such that *x* starts without the intervention of any cause external to *x*. In either case, we must understand (3) as involving implicit anaphora.

The two cases just given, of control and of anaphor-incorporation, will figure below in my plea for implicit anaphora. A number of examples of mixed anaphora are known, particularly those discussed in Mitchell (1986) and Partee (1989), where a word is understood as containing a θ -position related to a formative. The simplest are those where the position lies within a relational noun, as in (4):

- (4) Every participant had to defeat an enemy.

A salient meaning of (4) is that each participant *x* had to defeat someone who was an enemy of *x*. Representing the pertinent elements of the θ -grid of *enemy* as $\langle 1,2 \rangle$, with 2 the position for the internal argument, we conceive of the syntax as linking that position to the quantified DP *every participant* (or, in a bolder step, to the external θ -position of *defeat*, making (4) a case of implicit, rather than mixed, anaphora).

Implicit-anaphora examples go together with cases featuring ordinary pronouns, both showing a weak crossover effect. Thus we have data as in (5):

- (5) a Every participant had to defeat an enemy (of his).
 b ?An enemy (of his) had to defeat every participant.
 c How many participants had to defeat an enemy (of theirs).
 d ??How many participants did an enemy (of theirs) have to defeat?

It is natural to suggest, therefore, that binding theory should treat these in the same way. As far as (5) goes, it may be proposed that the examples without pronominals arise by some process of deletion. But other examples show that there may be no grammatical source for such deletion:

- (6) Every participant had to defeat yesterday's enemy's father.

In (6) we have the interpretation that every participant is an *x* such that *x* had to defeat the father of the person who yesterday was an enemy of *x*; but insertion of a pronominal is not possible:

- (7) Every participant had to defeat yesterday's enemy (*of his)'s father.

I will therefore assume that (4) and similar examples represent mixed anaphora.

Can mixed anaphora go in the other direction, from formative to θ -position? This question is much harder to answer, since the θ -position will have to be discharged somehow in the semantics (or else the sentence will not be closed), and the means of eliminating it might itself provide an antecedent for the formative. Partee (1989) observes that pronominals cannot in general freely take implicit antecedents. Consider (8):

- (8) Many [murderers <1,2>] know them beforehand.

(8) cannot mean: many murderers know their victims beforehand. On the other hand, we have notorious examples such as (9):

- (9) John buttered the toast, but he didn't do it in the bathroom.

Here the antecedent of *it* is understood to be John's action of buttering the toast, represented by the event-argument or E-position of the head V *butter*. This position is not discharged by θ -marking, and in standard accounts appears as bound by an existential quantifier. So for the first clause we have the interpretation shown in (10):

- (10) $(\exists e)$ butter (John,the toast, e)

However, it could be conjectured that it is the implicit quantification, taking sentential scope, that licenses the pronominal anaphora. In what follows I will leave the mixed cases to one side, with the exception of a brief critical discussion of Culicover & Jackendoff (1995).

My discussion in the sections following will concern control phenomena (section 2); anaphor-incorporation (section 3); and a mixed-anaphora analysis of the anaphoric character of the word *else*, contrasting it with the views of Culicover & Jackendoff. To the extent that the views defended here are on the right track, they may give substance to the plea that forms my title.

2 Implicit arguments and control

2.1 Preliminary data

In a terminology familiar from the coinage of Roeper (1987), an 'implicit argument' is seen in an example like (11) (due to M. Rita Manzini), where the understood subject of *sink* controls PRO:

(11) The boat was sunk (in order) [PRO to collect the insurance].

That it is the presence of the implicit argument, and not merely common-sense understanding, that licenses (11) is supported by the contrast between (11) and examples where an element is understood in a discourse, but not present in the thematic structure of the predicative head, and so not available as a controller of PRO. The examples are somewhat delicate, because for me and some other speakers PRO without any controller, explicit or implicit, is acceptable in a dialogue like (12):

(12) Q: Why is the boat at the bottom of the sea?
A: To collect the insurance.

where the interpretation is that whoever is responsible for getting the boat to the bottom of the sea intends to collect the insurance.² Still, in (13) such an interpretation is quite marginal:

(13) ?The boat is at the bottom of the sea [PRO to collect the insurance].

Manzini's and similar examples provide evidence that a θ -position discharged merely through existential closure is in some way visible to the syntax, and in particular may be the antecedent of a formative, in this case PRO. Other examples include (14), examined in Epstein (1984):

(14) [PRO playing chess] is enjoyable.

² The dialogue is perhaps still more nearly acceptable if the respondent himself is the one who intends to collect the insurance, and so supplies the reference for PRO.

The unique meaning of (14) is: for x to play chess is enjoyable for x (for any x of the right sort). We conclude, therefore, that the experiencer argument of *enjoyable* controls PRO, just as it does in (15):

(15) [PRO playing chess] is enjoyable for me.

But in (13) the experiencer argument of *enjoyable* is discharged by universal closure, not θ -marking.³ More elaborate cases of the type of (14) include (16):

(16) Friends are fun [O [PRO to be with t]].

which can be interpreted as shown in (17):

(17) If x is friend of y , then it is fun for y for y to be with x , for any x and y ⁴

A classical problem in the theory of control and anaphora is that of the understood subject of NP, which can behave as though controlled, and also act as antecedent for other elements. Consider (18):

³ The interpretation of (14) is necessarily generic, because of the properties of the English bare present in construction with indefinite arguments. In the past tense, as in (i), the interpretation need not be generic (universal):

(i) PRO playing chess (yesterday) was enjoyable.

But the remarks in the text still apply, since it is the implicit argument of *enjoyable*, anchored in context, that serves as the antecedent of PRO.

⁴ Notice that it is the binary character of the predicate *friend* that licenses the construction, by revealing two distinct argument positions. Thus it would be wrong to replace ' x is friend of y ' by ' x and y are friends' in (7), since that would allow (i) with a meaning like that given for (7), while omitting (ii) in that meaning:

(i) Lovers are fun to be with.

(ii) Mothers are fun to be with.

But (i) only means that if x and y are lovers, then it is fun for any z for z to be with x and y ; whereas (ii), whose head is a truly relational N, can mean that if x is mother of y then it is fun for y for y to be with x . The latter example, incidentally, also shows that we cannot interchange ' x ' and ' y ' in the consequent of (17).

- (18) My instruction to look at each other was unheeded.

The unique meaning is as indicated in (19):

- (19) The instruction from me to x , that x should look at each other, was unheeded by x .

for whatever people x are in question. The syntax shows PRO as subject of the clause *to look at each other*, and acting as the antecedent of the reciprocal. The controller of PRO is the implicit second object of *instruction*, which is in turn controlled by the implicit argument of *unheeded*, which derived from the agent argument of the root *heed*.⁵ The chain of control must go as stated. For example we cannot pass over the understood second object of *instruction*:

- (20) *My instruction to Mary to look at each other was unheeded.

2.2 Conceptions of implicitness

To this point I have been using the notion 'implicit argument' to mean: an open position (a θ -position) in a θ -grid.⁶ But this notion can be used purely descriptively, to signify θ -positions that are not realized overtly by (obvious) θ -marking (Roeper (1987) seems to me to shift between the descriptive sense and the more technical one).

The phenomenon of implicit arguments, taken in the purely descriptive sense, is evident from examples like (20) above, and also from what Roberts (1987) calls 'implicit subjects' of verbal passives, illustrated by (21):

⁵ Thus *unheeded* is like *uninhabited* and similar words in allowing a *by*-phrase but no corresponding active form: for discussion see Fiengo (1977).

⁶ Not all open positions are θ -positions in the classical sense; i.e., positions that must be discharged by θ -marking, or assigned to arguments, in accordance with the θ -criterion. The E-position, for example, is an open position that is never assigned to an argument, and the open positions of some derived nominals apparently need not be assigned to arguments, their overt realization being in this sense optional. For simplicity, however, I will here use 'open position' and ' θ -position' interchangeably. Note particularly that no substantial account of θ -roles is required for the applications pursued here: it will be enough that open positions are enumerated and distinguished from one another as part of lexical information.

- (21) The books were thrown away intentionally.

The understood subject of the adverb is linked to the understood agent of the passive form. Assuming that the adverb has exactly the θ -grid of the transitive adjective *intentional*, from which is it derived, we may render the semantics schematically as in (22) (see Higginbotham (1989b) for more detail):

- (22) $(\exists x)(\exists e)$ [threw away(x ,the books, e) & e was intentional of x]

The θ -position marked by 'x' in (22) is an implicit argument of the adverb. It does not yet follow, however, that (22) is a case of implicit, rather than mixed, anaphora; indeed, Roberts's view is that the passive affix *-en* may in fact *be* the suppressed external argument of the main V, serving as the antecedent for the adverbial position. Below I shall give some reasons for questioning this analysis; but in principle the case could go either way.

Brody & Manzini (1987) understand implicit arguments in a sense that appears to conform to the technical usage suggested here; i.e., θ -positions not discharged by θ -marking. They defend implicit argument control for cases like (11); but any such defense must consider various problematic examples, to which we now turn.

2.3 Contexts disallowing control

Howard Lasnik (in discussion with the author, from some years back) has observed that a number of cases superficially similar to canonical examples such as (11) nevertheless fail to allow control, giving as a representative example (23):

- (23) *The boat was sunk (in order) [PRO to become a hero].

which contrasts with (24):

- (24) ?The boat was sunk by the sailor (in order) [PRO to become a hero].

These cases are problematic for an account such as Roberts (1987), since on his view an antecedent, namely the passive affix, is equally linguistically present for both (23) and (24). But they are problematic also for an account of control in terms of implicit

arguments, unless indeed an appropriate distinction can be made out between cases that do and cases that do not require the syntactic realization of a controller. Following the typology of Faraci (1974), we distinguish between the *purpose clause* (PC), which may show both control and a 'gap' (assumed syntactically to be a chain consisting of an empty operator and a trace, as proposed in Chomsky (1977)), and the *rationale clause* (RC), optionally preceded by a head like *in order, so as*, etc., which shows control, but no gap. The contrast is exemplified in (25)-(26):

- (25) I bought the violin (*in order) [O [PRO to play sonatas on *t*]].
 (26) I bought the violin (in order) [PRO to play sonatas on it].

I will suppose following Whelpton (1995) that in (26) the subject of the adjunct is the event of buying the violin, and the RC is its internal argument, the object of *in*, or *in order*. The head itself expresses a relation between an event (here, buying the violin) and the content of an intention that its agent tried to fulfill by bringing the event to pass (here, playing sonatas on it). The head may not be overt, but constitutes the 'nexus' in the sense of Jespersen, mediating between the main clause and the RC. For the PC, I assume that the nexus is triadic, expressing a relation between an object (the violin), an event (possessing the violin in consequence of buying it), and the property expressed by the PC by taking *O* to express λ -abstraction over the position marked by *t* (here, λx (I play sonatas on *x*)); see Whelpton (1995) for further details, not relevant here.

PC, it appears, regularly show control by an implicit argument, as in (27):

- (27) The bones were bought [O [PRO to give *t* to the dog]].⁷

In fact we do understand (11) (minus *in order*) as a PC, although it has no syntactic gap: for it is clear that it is the insurance *on the boat* that is to be collected. Inversely, infinitival adjuncts like that in (23), but with a manifest syntactic gap, are more acceptable than (23) itself. There is a clear contrast, for instance, between (28a) and (28b):

⁷ The controller, the understood buyer of the bones, need not be the one who puts them in position for the dog to eat, and in that sense need not be the 'giver' of the bones: I can, at least with license, truly say that the bones were bought by me to give to the dog even if I intend someone else actually to hand them over to the animal. But the same is true where the antecedent of PRO is explicit, as in (i):

- (i) I bought the bones yesterday [O [PRO to give *t* to the dog]].

- (28) a ?The boat was sunk [*O* [PRO to become a hero for [PRO having sunk *t*]]].
 b *The boat was sunk [PRO to become a hero for having won the battle].

If so, then we can lay the relative unacceptability of (23) to the difficulty of taking it as a PC, and the relative acceptability of Manzini's original example (11) to the availability, through the internal argument of the derived nominal *insurance*, of an element that makes it construable as a PC.

What can be said about the RC construal, with *in order*? As a syntactic matter an RC cannot contain a gap; but it certainly can contain a pronominal referring back to an element of the main clause (apart from the agent, which always controls PRO). Thus we may conjecture that an implicit argument in (11) (the object of *insurance*) facilitates the perception of control by removing a potential controller, the surface subject, from consideration.

We have, then, a partial although incomplete response to Lasnik's observations. PC show control by implicit arguments; but both PC and RC are the more acceptable with implicit argument control in proportion as an implicit argument is supplied whose antecedent is the surface subject, as in (11). Predicates like Lasnik's *become a hero* are low on the scale, since they do not supply implicit arguments. Hence their use as RC biases control toward the surface subject, semantic absurdity notwithstanding, thus generating typical contrasts such as (29)-(30) and (31)-(32):

- (29) I studied the book [in order [PRO to be well-educated]].
 (30) The book was studied [in order [PRO to be well-educated]].
 (31) The book was put on the shelf [in order [PRO to be consulted *t* as the need should arise]].
 (32) I put the book on the shelf [in order [PRO to be consulted *t* as the need should arise]].

In all of these examples, the only accessible controller of PRO is the subject.

Supposing now that both controller and controlled may be realized only implicitly, as in the cases we have given, we may consider a theory according to which PRO is a syntactic reflex of control, rather than the controlled element itself; that is, PRO is selected to occur in certain configurations where control has already been established. The syntactic restrictions on the occurrence of PRO remain in force, but anaphora into positions other than those in which PRO can occur can remain at the level of the implicit argument.

In fact we may go farther. Suppose that, control or contextual anchoring of an implicit argument having been established, that argument must be realized, for independent reasons. There are two cases of this, namely (i) where the implicit arguments of the head must be discharged by θ -marking, and (ii) where a position must be syntactically realized on independent grounds. The former case is that of the θ -positions of the head that interact with the θ -criterion; and the latter is that of the subject of a clause, the cases that fall under the Extended Projection Principle. In case (i) PRO is excluded except from an ungoverned subject position, and by (ii) something must be realized in such a position. Hence, if no other expression can fulfill its role, as appears to be the case in English, PRO occurs where, and exactly where, it can. Control itself, however, is indifferent to its occurrence.

Fiengo & Higginbotham (1981) gave examples of control into the external-argument position of N, as in (33):

(33) Bets against him don't bother John.

Our observation was that anaphora between *him* and *John* imply that it is not John who is betting.⁸ In (34), where control is obligatory, anaphora are not possible:

(34) [PRO betting against him] doesn't bother John.

The data suggest that the only difference between the cases stems from the fact that control is not required in (33). As many people have observed, positing PRO in (33) and the like is hard to defend: not only does the subject seem complete by itself, but it can even be supplemented with a genitive (*yesterday's bets against John*), without disturbing the control relation. Moreover, if PRO were present in (33) there is no evident reason why control should not be as obligatory, as it is in (34). On the present view, as in Williams (1994), these issues do not arise.

⁸ More simply, nominals like *bets against him* show the same condition B effect as simple sentences *NP bet against him*.

3 Incorporated anaphora

Consider examples such as: *self-inflicted (wound)*, *other-regarding (action)*, *different-sounding (syllables)*, *same-looking (cars)*. In these the semantics must be done through communication between implicit arguments. They represent a kind of head-incorporation, but are evidently (in the case of the latter three), or arguably (in the case of *self-*, as discussed below), not themselves capable of discharging a θ -position. The constructions are of variable productivity, partly for elementary semantic reasons, but invite comparison with N-incorporation and an analysis of the general basis for the semantics that they receive.

It has long been observed that some cases of *self-incorporation* carry the obvious reflexive meaning. Consider again (3), expanded below as (35):

(35) a self-starting motor

One can say that a motor x is self-starting if it is such that x starts x , and the construction so understood is synonymous with *motor that starts itself*. The Adjective *self-starting* combines with the head Noun by unification or θ -identification, and the morpheme *self* has the effect of identifying the internal with the external implicit argument of *starting*. I will represent this syntactic transaction and the resulting semantic interpretation as shown in (36):

(36) a self-starting motor
 a [[self-starting, <1,2>, 2=1] [motor <3>], <3>, 1=3]
 an x such that motor(x) & x starts x

As above, the θ -positions are shown within angled brackets. Identification of θ -positions is shown by equations whose left side is the modifier and whose right side is the modified, an arbitrary convention to this point. Thus *self-starting* contains two θ -positions, which are identified, and these in turn are identified, as shown by the annotation '1=3', with the sole θ -position 3 of *motor*.

Chomsky (1972), in the course of arguing in favor of the lexicalist hypothesis, and against the suggestive evidence for a transformational derivation of constructions like (35), considered a number of cases of *self-incorporation*. I discuss these examples, and others, below. For the moment, let us consider how the θ -positions in *self-*

incorporation are identified, a question left open by the neutral notation ' $2=1$ ' in (36) above.

It is straightforward to verify that when a *N* incorporates into an $A=V+ing$, then it fills the internal argument position of *V*, and that *N*-incorporation into $A=V+en$, formed with the participial affix, fills instead the position that would be external in the active form of *V*. Thus contrast (37)(a)-(b):

- (37) a a Wall Street-sustaining enterprise
 b a Wall Street-sustained enterprise

These have the interpretations in (38)(a)-(b), respectively:

- (38) a an enterprise *x* such that *x* sustains Wall Street
 b an enterprise *x* such that Wall Street sustains *x*⁹

Taking a cue from these data, we conclude that the *self* morpheme when incorporated acts in a specific direction, so as to identify an internal θ -position with the external one (in the case of *-ing*), or to identify the external position with an internal one (the case of *-en*). Let us say that the morpheme *targets* a position *n*, and *identifies* it with position *m*. If so, then we should not regard the direction of θ -identification with indifference, but endow it with a significance reflected in the notation for (36) and other examples.

Our question whether there is a direction of θ -identification arises also for the simpler case of modifier-head relations: are these symmetric or asymmetric? It is natural to suppose that they proceed from the modifier to the head; that is, that θ -identification targets a position of the modifier and identifies it with a position of the head. We shall make this assumption in what follows.

In place of the equations seen in the third line of (36) we now put assignments of target *n* with identified position *m*, signaled by the notation: ' $n=>m$ '. Thus (36) is replaced by (39):

- (39) a self-starting motor
 a [[self-starting, <1,2>.2=>1] [motor <3>], <3>, l=>3]
 an *x* such that motor(*x*) & *x* starts *x*

⁹ or: *x* is sustained by Wall Street.

Because of the reflexivity of *self-*, we can represent the semantics in (39) without assigning that morpheme any meaning other than that of triggering the anaphora. But consider reciprocal examples, as in (40):

- (40) an other-regarding action
 an x such that action(x) & the agent y of x has regard for some $z \neq x$

or examples with *different*, as in (41):

- (41) different-sounding syllables
 syllables x each of which is different from the others in x

In these cases the semantics must be mediated by the meanings of *other* and *different* themselves. For the case of *other*, we shall want a θ -grid [*other*, <1,2>], which will combine with [*regarding*, <3,4>], by identifying 2 with 4; and similarly for *different*, and for that matter *same*. Illustrating with reference to (40), we shall have (42), where the nominal carries a position for the agent:

- (42) an other-regarding action
 an [[[*other*, <1,2>] [*regarding*, <3,4>], <1,3,4>, 2=>4] [*action*, <5, 6>], <1,5,6>, 3=>5, 1=>6]

But now we may propose that *self*, itself, contributes a meaning, namely identity.¹⁰

In general, the forms *self*+gerund have quite regular interpretations, as indicated for instance by examples like those in (43):

- (43) a self-canning beer
 b self-seeking man
 c self-breaking chinaware

¹⁰ There are of course intimate relations between the conception thus arrived at and recent discussions of reflexives that have them incorporate into verbal heads; but I pass over these issues here for lack of space.

(43a) evidently means: beer that puts itself in a can; (43c) refers to chinaware that breaks of its own accord (with inchoative *break*), or alternatively to chinaware that breaks itself (with causative *break*); (43b) is not generally understood to mean *man who seeks himself*, but rather *selfish man*, or perhaps *man who seeks things (only) for himself*, but it is clear on reflection that it *has* the purely reflexive meaning, usage notwithstanding. The last remark goes also for examples like (44a-b), of which the first is discussed in Chomsky (1972):

- (44) a self-fulfilling prophecy
b self-standing statue

Chomsky (1972:57-58) writes that (44a) “does not, strictly speaking, mean that the prophecy fulfills the prophecy, which is senseless, but rather than it led to a state of affairs that fulfilled the prophecy.” This characterization of the common meaning can, I think, be improved: (44a) is a clever coinage, applying to acts of prophecy having the property that making them causes the fulfillment of their contents. In any case, the crucial question for the status of (44a) in the grammar is whether the ‘senseless’ meaning is in fact available. It seems to me that it is.

The example (44b) raises a different set of issues. As illustrated above with respect to (43c), inchoatives may allow *self-incorporation*, and (44b) is acceptable with the meaning *statue that stands by itself (without the aid of props)*. The pattern is not, however, generalizable: thus we do not have **self-lying rug*, **self-sitting doll*, etc., or examples like *self-walking dog* except with causative *walk*.

Turning now to the participial and derived nominal forms, we find a regular pattern overlain with special usages, and a possibility that does not obtain with the gerund, of identifying an agent, extraneous to the θ -grid of the head, with a position in the θ -grid. Recall that examples like (37b) show that an incorporated N identifies its θ -position with the external argument position of a participle, and that *self-incorporation* consequently works ‘downwards,’ from the external position to an internal one. Examples such as those (45) then have the expected meanings shown:

- (45) a self-canned beer = beer which the beer itself puts in the can
b self-sought man = man who he himself seeks

But (45a) has another interpretation as well, namely *beer that is canned by the one who made it*. Similar remarks go for the examples in (46):

- (46) self-addressed envelope, self-decorated house, self-derived conclusion

Finally, examples with derived nominals show both the 'regular' (often silly in practice) interpretations, as well as scattered available readings that reflect the importation of an outside agent, as in (47):

- (47) self-storage facility, self-discovery, self-service machine,

Thus a self-storage facility can be a facility where one stores oneself, but (in a non-cryogenic age) is used just to mean a facility where one stores one's belongings by oneself; *self-discovery* refers to the act of discovering one's 'true self,' and a self-service machine (in British English) is one that serves goods after the insertion of coins (but can be interpreted to mean a machine that serves itself).

Summing up, the *self*-incorporated forms diverge from what is made available by ordinary reflexive contexts, but contain the meanings given by those contexts as special cases, even where usage assigns them other salient meanings. The gerundives come closest to exhibiting regular behavior; the participles, even where regular, do not follow the lines of syntactic reflexivization, since they target an internal argument, identifying it with the external, whereas syntactic reflexives must follow the reverse pattern; participles and derived nominals allow the importation of agents not given in the θ -grids of the heads; and there is a (limited) variety of special cases. These data are consistent with Chomsky's support for a lexicalist position with respect to *self*-, and more generally anaphor-, incorporation, but show at the same time a systematic character that can be expressed only at the level of implicit anaphora.

4 *Else*

Culicover & Jackendoff (1995) have discussed anaphora with (*something*) *else*, as seen for instance in (48).

- (48) Everyone loves someone else.

in the meaning: everyone is an x such that x loves someone other than x . Since they regard the expression *else*, or the containing nominal, as itself anaphoric, they conclude

on the basis of clause-bound anaphora as in (48) and longer-distance anaphora as in (49) that *someone else* has the distribution of both anaphors and pronominals.

(49) Everyone thought that I saw someone else.

In fact, they go so far as to suggest that these anaphora violate condition (C), citing (50):

(50) Someone else wrote Shakespeare's plays.

Of course, these conclusions are induced only by the assumed formalism of cosubscripting elements as wholes. The consequences for the theory of explicit anaphora are sufficiently drastic that the alternative suggests itself, that these anaphora are triggered by the specific meaning and the argument structure of the anaphoric element *else*, and so engage the semantics at the level of implicit arguments.

Let us return to the point that *someone else* evidently means *some person y other than person x*, where the value of 'x' is determined contextually, or else the position it occupies is that of a bound variable; and similarly for *no one/anyone/everyone else*. We may take it that *else*, despite its limited distribution, effectively means *other than*, and combines with the head, *one* as illustrated by (51):

(51) [[one,<1>] [else,<2,3>],<1,3>,2=>1]

where 3 is anaphoric, in the case of (50) to *Shakespeare*.¹¹

The alternative just sketched responds at once to the suggestion of Culicover & Jackendoff, that the anaphoric properties of *else* will have to be specified at some level other than those recognized by customary syntax. They write in (1995:272) that the construction *X else* should be 'decomposed' as 'x other than α , where α is an anaphoric element,' where α is 'not present in the syntax at all.' But thematic structure is present in the syntax, and if we allow, as it appears we must on independent grounds, that θ -positions can themselves participate in anaphoric relations, then their conclusion is not warranted.

¹¹ The head expression need not be *one*, since, e.g. *every man else* and similar constructions are attested. On the other hand, the quantifier (in the count system) must apparently be either universal or existential, since we do not have **many men else* and the like; but for the mass system cf. *little else*, *much else*.

There are in fact other reasons for supposing that *else*-anaphora are syntactically represented. Contrary to the judgements of Culicover & Jackendoff (1995:226-227), I find that *else*-anaphora obey the crossover conditions:¹²

(52) It was everyone else that everyone met.

(53) It was everyone that everyone else met.

(52) can mean that everyone is an *x* such that *x* met everyone *y* other than *x*; but (53) cannot mean that everyone is an *x* such that everyone *y* other than *x* met *x*. The cases are parallel to (54)-(55):

(54) It was everyone other than *him* that *everyone* met.

(55) ??It was *everyone* that everyone other than *him* met.

But I suggest that no decomposition of anything is called for; rather, we should recognize in the structure of the word *else* itself the possibility of anaphora, and apply weak crossover conditions to the relation between the position marked 3 in (42) above and the quantificational antecedent *everyone* in (52)-(53). In support of this hypothesis are the considerations below.

Higginbotham (1989a:92,96) advanced the generalization that both PRO and understood subjects always show what was there called *covariance* with their antecedents under association with focus and VP-deletion. Covariance in the latter case ('sloppy identity') shows up with *else*-anaphora as well. Thus (56), in contrast to (57), does not admit a 'strict' or invariant reading:

(56) Shakespeare liked someone else's plays, but Marlowe didn't.

(57) Shakespeare liked the plays of someone other than him.
(Shakespeare), but Marlowe didn't.

Similarly, for the case of association with focus, compare (58) to (59):

(58) Only Shakespeare likes someone else's plays.

(59) Only Shakespeare likes plays by someone other than him.

¹² In fact, Culicover & Jackendoff vacillate on this point, since in (1995:262) they suggest that such conditions are in effect.

The example (58) is ambiguous in the usual way, between the invariant (60) and the covariant (61):

- (60) Only Shakespeare is an x such that x likes plays by someone other than Shakespeare.
 (61) Only Shakespeare is an x such that x likes plays by someone other than x .

But the invariant or strict interpretation is unavailable for (58). These data suggest that Culicover & Jackendoff's recourse to decomposition is not only unnecessary but as it stands misleading, since the result of restoring an argument for *else* cannot, unlike pronominals, show strict identity interpretations.

I have suggested that *else* means *other than*, and carries two implicit arguments. This thesis is supported independently by the free occurrence of *else* with disjunction. The addition of *else* forces an extra dimension of interpretation in (62):

- (62) You must go, or (else) you will be late.

(62) invites a conditional interpretation, 'If you do not go,' i.e., 'if you do otherwise than go, you will be late' for the second disjunct. In one natural interpretation of (63), the 'free-choice' interpretation discussed in Higginbotham (1991), the addition of *else* implicates that one and only one alternative is permitted:

- (63) You are allowed to play chess or (else) checkers here.

Furthermore, in contexts that escape tautology through Gricean implicature, as in (64) said in response to the question whether one will be at the party, the addition of *else* creates anomaly:

- (64) I may go, or I may not.
 (65) ?I may go, or else I may not.

We thus have, from within the contemporary language, ample evidence that *else* involves the concept *other than* as part of its thematic structure.

5 Concluding Remarks

The selected cases discussed here are evidence that the general theory of anaphoric relations in syntax should be extended to include implicit anaphora, not at a hypothetical level of the representation of full discourse and communication, but at the classic level, where syntactic structures and the form and meaning of lexical items impose their own conditions on possible interpretations. Besides these cases there are a number of others, including for example tense-agreement phenomena and sequence of tense, which limitations of space have precluded discussing here. If so, then the question arises what lexical items are permitted to bear the anaphoric relations in question. It can be no accident, for example, that the incorporated anaphora *over* and *over* employ the notions of identity and non-identity, or that words like *else*, *another*, and *different* appear in this connection. But for this point a wider cross-linguistic survey is needed.

References

- Brody, Michael. & M. Rita Manzini. 1987. On Implicit Arguments. In Ruth M. Kempson, (ed.) *Mental representations: The Interface Between Language and Reality*. Cambridge: Cambridge University Press. 105-130.
- Chomsky, Noam. 1972. Remarks on Nominalization. In *Studies on Semantics in Generative Grammar*. The Hague: Mouton. 11-61.
- Chomsky, Noam. 1977. On Wh-Movement. In Peter W. Culicover, Thomas Wasow, & Adrian Akmajian (eds.) *Formal Syntax*. New York: Academic Press. 71-132.
- Chomsky, Noam. 1981. *Lectures on Government and Binding*. Dordrecht: Foris Publications.
- Culicover, Peter W. & Ray Jackendoff. 1995. *Something Else* for the Binding Theory. *Linguistic Inquiry* 26. 249-276.
- Epstein, Samuel. 1984. Quantifier PRO and the LF-Representation of PRO-ARB. *Linguistic Inquiry* 15. 499-505.
- Faraci, Robert. 1974. *Aspects of the Grammar of Infinitives and For-Phrases*. Doctoral dissertation. Cambridge, Mass: MIT.
- Fiengo, Robert. 1977. On Trace Theory. *Linguistic Inquiry* 8. 35-61.
- Fiengo, Robert & James Higginbotham. 1981. Opacity in NP. *Linguistic Analysis* 7. 395-421.
- Higginbotham, James. 1983. Logical Form, Binding, and Nominals. *Linguistic Inquiry* 14. 395-420.
- Higginbotham, James. 1989a. Reference and Control. *Rivista di Linguistica* 1. 301-326. Reprinted with minor revisions in Richard Larson, Sabine Iatridou, Utpal Laha & James Higginbotham (eds.) *Control and Grammar*. Dordrecht: Kluwer. 79-108.
- Higginbotham, James. 1989b. Elucidations of Meaning. *Linguistics and Philosophy* 12. 465-517.
- Higginbotham, James. 1991. Either/Or. *NELS XXI Proceedings*. University of Massachusetts, Amherst: GLSA.
- Mitchell, Jonathan. 1986. *The Formal Semantics Point of View*. Doctoral dissertation. University of Massachusetts, Amherst.
- Partee, Barbara. 1989. Binding Implicit Variables in Quantified Contexts. *Chicago Linguistics Society* 25. 342-365.
- Roberts, Ian. 1987. *The Representation of Implicit and Dethematized Subjects*. Dordrecht: Foris Publications.
- Roeper, Thomas. 1987. Implicit Arguments and the Head-Complement Relation. *Linguistic Inquiry* 18. 267-310.
- Whelpton, Matthew. 1995. *The Syntax and Semantics of Infinitives of Result in English*. Unpublished D.Phil. thesis. University of Oxford.
- Williams, Edwin. 1994. *Thematic Structure in Syntax*. Cambridge, Mass: The MIT Press.

Sloppy Identity and Principle B

Hajime Hoji

1 Introduction: two conceptions of Binding Principle B*

The marked degradation of examples like (1), in contrast to (2), under the interpretations as indicated, has been attributed to a principle that is sensitive to the structural closeness of the two nominal expressions at issue.

- (1) a * $\{ \text{No/That} \}$ software company_i recommended it_i for that project.
b * $\{ \text{No/That} \}$ software company_i claims it_i to be the most suitable for that project.
- (2) a $\{ \text{No/That} \}$ software company_i recommended its_i subsidiary for that project.

* This is a modified version of "Sloppy Identity and Bound Variable Anaphora," presented at the Workshop on 'Atomism' and Binding at Leiden University, February 15-17, 1996. Most of the developments subsequent to the workshop, such as those presented in the spring 1997 seminar at USC, are in general not included in this paper. My forthcoming work *Formal Dependency and Organization of Grammar* (MIT Press) will contain a substantially more comprehensive and more articulated view of the proposal, part of which this paper is an interim report of. I am much indebted to Ayumi Ueyama for her extensive comments and suggestions on earlier versions of this paper. I also wish to thank Yuki Takubo for his comments on an earlier version of this paper. I have also benefited from discussions with and/or comments from Andy Barss, James Higginbotham, Ai Kawazoe, Satoshi Kinsui, Audrey Li, Ann Lobeck, Yuki Matsuda, Robert May, Keiko Miyagawa, Barry Schein, Caroline Scherzer, Daniel Seely, Karina Wilkinson, as well as the students in my USC syntax courses and the audiences at University of Arizona, Kyushu University, Kanda University of International Studies and University of Tokyo, where portions of this work have been presented. This work has been supported in part by Monbusho (Education Ministry of Japan) International Scientific Research Program: Joint Research, Grant No.08044009, Comparative Syntax of Japanese, Korean, Chinese and English.

- b $\{ \{ \text{No/That} \} \text{ software company} \}_i$ claims that it_i is the most suitable for that project.

The principle is called Binding Principle B.

This paper is concerned with the question of what formal relations Principle B is to restrict. There are two representative views on this. One regards the principle as regulating coindexation, a symmetrical relation, as in Chomsky (1981), or its modified versions such as Reinhart (1983: Ch. 7), where its application is in effect restricted to the cases of bound variable anaphora. The other considers this principle to restrict an asymmetrical relation, dependency/linking, as in Higginbotham (1983); cf. also Evans (1980). In this paper, I argue, in support of the second approach, that Principle B must be understood as a condition on a formal relation of dependency, which shall be called Formal Dependency, while maintaining the conclusion in Hoji (1995) that Principle B does not regulate coreferential relations among nominals, as argued in Reinhart (1983: Ch. 7).¹

In section 2, I will present initial evidence that Principle B is on Formal Dependency, rather than on coindexation. In section 3, further evidence for this conclusion will be provided, based on certain types of interpretive possibilities involving a sloppy identity reading. In section 4, I will suggest an account of why *it recommended it* in English does not allow coreference while its Japanese counterpart does. The proposed account is an attempt to solve the long-standing problem of how to deal with "coreference residue of Principle B" under the view that Principle B is a condition on Formal Dependency or on bound variable anaphora.

¹ As in Hoji (1997b), I assume the following three necessary conditions for the establishment of Formal Dependency between A and B. FD(A,B).

- (i) If FD(A,B), then
- a. B is a β -occurrence in the sense of Fiengo & May (1994) (stated slightly differently in Hoji (1997b))
 - b. A c-commands B, and
 - c. A is not in the local domain of B.

FD(A,B) is a formal relation, which is part of the LF representation. I thus maintain, as in Hoji (1997b), that FD itself is a legitimate LF object. I further assume, also as in Hoji (1997b), that the establishment of an FD is a necessary condition for bound variable construal. The following presentation, however, is mostly based on works prior to Hoji (1997b); see note 28.

2 Principle B and Formal Dependency

It is concluded in Hoji (1995) that *soko* 'it/that place' is singular-denoting based on the observation that it cannot allow split antecedence, in contrast to *they* in English, and *karera* in Japanese, which is generally translated as human 'they'.

- (3) *Toyota₁-ga Nissan₂-ni [_{CP} CIA-ga soko₁₊₂-o
 Toyota-NOM Nissan-DAT CIA-NOM it-ACC
 sirabeteiru to] tugeta.
 is:investigating that told (based on Hoji 1995, (16))
 'Toyota₁ told Nissan₂ that the CIA was investigating it₁₊₂.'

Despite this, *soko* can be anaphorically related with a conjoined NP as is indicated in (4).

- (4) [Toyota to Nissan (to)]₁-ga Mazda-ni [_{CP} CIA-ga soko₁-o
 Toyota and Nissan-NOM Mazda-DAT CIA-NOM it-ACC
 sirabeteiru to] tugeta.
 is:investigating that told (based on Hoji 1995, (17))
 '[Each of [Toyota and Nissan]]₁ told Mazda that the CIA was investigating it₁.'

Given the singular-denoting nature of *soko*, the anaphoric relation between *soko* and the conjoined NP in (4) cannot be that of coreference; it seems natural to assume that it involves bound variable anaphora.² The contrast between (5) and (6) is then as expected, provided that the distribution of bound variable anaphora is regulated by Principle B.³

² Given that the anaphoric relation between *soko* and a conjoined NP has to be an instance of bound variable anaphora, as we are assuming here, and given that bound variable anaphora is subject to the standard c-command requirement, we expect Weak Crossover effects when *soko* is not c-commanded by (the trace of) the conjoined NP (at the relevant level of representation). Hoji (1995: (18a)) observes that this is indeed a correct prediction; see also Hoji (1997b: sec. 2.2).

³ As discussed and analyzed in some depth in Ueyama (1997a, 1997b), there are some factors, which I do not discuss in this paper, that affect the availability of what appear to be the bound variable readings under discussion. Much of the complications in (5) and (6) are invoked in an attempt to show the intended contrast more clearly than otherwise, by controlling such factors, without explicitly providing their analyses here.

- (5) a (Sono kaigi-no dookoo-o sagurootositeita)
 (that meeting-GEN development-ACC was:trying:to:spy:on)
 tyoosain-wa [[Toyota to Nissan]₁-ga [soko₁-no
 investigator-TOP Toyota and Nissan-NOM it-GEN
 sitauke]-o suisensuru]-no-o mite odoroitā.
 subsidiary-ACC recommend -ACC saw:and was:surprised
 'The investigator (who was trying to spy on the development of that
 meeting) was surprised to see [[each of Toyota and Nissan]₁ recommend
 its₁ subsidiary].'
- b (Sono kaigi-no dookoo-o sagurootositeita)
 (that meeting-GEN development-ACC was:trying:to:spy:on)
 tyoosain-wa [[Toyota to Nissan]₁-ga [_{CP} FBI-ga soko₁-o
 investigator-TOP Toyota and Nissan-NOM FBI-NOM it -ACC
 sirabeteiru to] happyoosuru]-no-o kiite odoroitā.
 is:investigating that announce -ACC heard:and was:surprised
 'The investigator (who was trying to spy on the development of that
 meeting) was surprised to hear [[each of Toyota and Nissan]₁ announce
 that the FBI was investigating it₁].'
- c (Sono kaigi-no dookoo-o sagurootositeita)
 (that meeting-GEN development -ACC was:trying:to:spy:on)
 tyoosain-wa [iintyoo-ga [Toyota to Nissan]₁-ni
 investigator-TOP chairperson-NOM Toyota and Nissan-DAT
 soko₁-no atarasii bengosi-o suisensuru] no-o mite odoroitā.
 it-GEN new attorney-ACC recommend -ACC saw:and was:surprised
 'The investigator (who was trying to spy on the development of that
 meeting) was surprised to see [the chairperson recommend to [each of
 Toyota and Nissan]₁ its₁ new attorney].'
- (6) a *(Sono kaigi-no dookoo-o sagurootositeita)
 (that meeting-GEN development -ACC was:trying:to:spy:on)
 tyoosain-wa [[Toyota to Nissan]₁-ga [soko₁-o
 investigator-TOP Toyota and Nissan-NOM it-ACC
 suisensuru]-no-o mite odoroitā.
 recommend -ACC saw:and was:surprised
 'The investigator (who was trying to spy on the development of that
 meeting) was surprised to see [[each of Toyota and Nissan]₁ recommend
 it₁].'

- b *(Sono kaigi-no dookoo-o saguroositeita)
 (that meeting-GEN development -ACC was:trying:to:spy:on)
 tyoosain-wa [iintyoo-ga [Toyota to Nissan]_i-ni
 investigator-TOP chairperson-NOM Toyota and Nissan-DAT
 soko_i-o suisensuru] no-o mite odoroitā.
 it-ACC recommend -ACC saw:and was:surprised
 'The investigator (who was trying to spy on the development of that
 meeting) was surprised to see [the chairperson recommend to [each of
 Toyota and Nissan], it_i].'⁴

Note that the structural relation between the conjoined NP and *soko* is local in (6), while it is not in (5). Hence the bound variable anaphora is disallowed in (6), in accordance with Principle B. The contrast also obtains in examples with other quantificational NPs such as *Toyota sae* 'even Toyota', *Toyota dake* 'only Toyota', *Toyota toka Nissan toka* 'Toyota, Nissan and so on' and *kanarinokazu-no N* 'a good number of N', although the relevant examples are not supplied here for reasons of space.

If *Toyota to Nissan* is replaced by *Toyota* and *soko* by *asoko* in (5) and (6), the coreference possibility does not seem to be affected by the relevant locality.⁵

- (7) a (Sono kaigi-no dookoo-o sagurooto siteita) tyoosain-wa
 [Toyota_i-ga asoko_i-no sitauke-o suisensuru]-no-o mite odoroitā.
 'The investigator (who was trying to spy on the development of that
 meeting) was surprised to see Toyota_i recommend its_i subsidiary.'
- b (Sono kaigi-no dookoo-o sagurooto siteita) tyoosain-wa [iintyoo-ga
 Toyota_i-ni asoko_i-no raibaru gaisya-o suisensuru]-no-o mite odoroitā.
 'The investigator (who was trying to spy on the development of that
 meeting) was surprised to see the chairperson recommend to Toyota_i its,
 rival company.'

⁴ The English translation here is meant to remind the reader that the *ni*-marked argument c-commands the *o*-marked argument in examples like (5c), (6b) and (8b).

⁵ As is well known, the availability of coreference is, in general, affected by a number of syntactic as well as non-syntactic factors. I do not therefore claim that the coreference as indicated is readily available in (7) and (8) for any speaker. I do claim, however, that if one accepts the coreference possibility in (7), then the availability of the coreference option is not affected in (8) in the same way that the possibility of the anaphoric relation in (5) becomes significantly reduced in (6).

- (8) a (Sono kaigi-no dookoo-o sagurooto siteita) tyoosain-wa
 [Toyota₁-ga asoko₁-o suisensuru]-no-o mite odoraita.
 'The investigator (who was trying to spy on the development of that meeting) was surprised to see Toyota₁ recommend it₁.'
- b (Sono kaigi-no dookoo-o sagurooto siteita) tyoosain-wa
 [iintyoo-ga Toyota₁-ni asoko₁-o suisensuru]-no-o mite odoraita.
 'The investigator (who was trying to spy on the development of that meeting) was surprised to see the chairperson recommend to Toyota₁ it₁.'

Given the assumption, made in Hoji (1995, 1997b), that the establishment of Formal Dependency (FD) is a necessary condition for bound variable anaphora, the status of (6) in contrast to that of (4), (5), (7) and (8), can be accounted for if Principle B is a condition on the establishment of FD.⁶ This can, however, be accounted for also under the assumption that Principle B is a condition on coindexation, if its application is, as in Reinhart (1983: Ch.7), restricted to cases of bound variable anaphora.

Now, consider the examples in (9).⁷

⁶ One may object that if Principle B is a condition on the establishment of Formal Dependency rather than on coindexation, there should not be anything wrong, in principle, with coreference in examples like *he recommended him* and *it recommended it*. I will return to this in section 3.

⁷ The observation in (9), which can be made also with other quantificational NPs, has been inspired by Heim's (1992) discussion of analogous English examples such as (i), which, according to her, are acceptable only in certain contexts in which "structured meanings" matter. Higginbotham (1992: section 4.2) also contains discussion of much relevance.

- (i) (based on Heim 1992: (20))
 Everyone said that what he had in common with his siblings was that his sister admired him, his brother admired him, and he (himself) admired him.

Unlike their English counterparts, examples like (9) allow the bound reading without any special contexts. This is not surprising, given the sharp contrast between (ii-a) and (ii-b).

- (ii) a *It_i recommended it_i.
 b Soko_i-ga soko_i-o suisensita.
 'It_i recommended it_i.'

My conclusion in this paper, however, differs from Heim's (1992). I claim in this paper that Principle B consists solely of the inviolable part of Heim's Principle B, i.e. that part of the principle that regulates dependency, excluding the other part of her Principle B, i.e. that part of her Principle B that regulates codetermination, which is violable due to her "Exceptional Coindexing Rule."

- (9) a (Sono kaigi-no dookoo-o sagurootositeita)
 (that meeting-GEN development -ACC was:trying:to:spy:on)
 tyoosain-wa [Toyota to Nissan]_i-ga [_{CP} soko_i-ga soko_i-o
 investigator-TOP Toyota and Nissan-NOM it-NOM it-ACC
 suisensita to] happyoosuru no-o mite odoroitā.
 recommended that announce -ACC saw:and was:surprised
 'The investigator (who was trying to spy on the development of that
 meeting) was surprised to see [each of Toyota and Nissan]_i announce that
 it_i had recommended it_i.'
- b (Sono kaigi-no dookoo-o sagurootositeita) tyoosain-wa
 (that meeting-GEN developmentACC was:trying:to:spy:on) investigator-TOP
 [iintyoo-ga [Toyota to Nissan]_i-ni [_{CP} soko_i-ga soko_i-o
 chairperson-NOM Toyota and Nissan-DAT it-NOM it-ACC
 suisensu-ru bekida to] tutaeru no-o mite odoroitā.
 recommend should that tell -ACC saw:and was:surprised
 'The investigator (who was trying to spy on the development of that
 meeting) was surprised to see the chairperson tell [each of Toyota and
 Nissan]_i that it_i should recommend it_i.'

The intended interpretations of the relevant clause in (9) are as in (10).

- (10) a for all x , $x \in \{\text{Toyota, Nissan}\}$, x announce that x had recommended x
 b for all x , $x \in \{\text{Toyota, Nissan}\}$, the chairperson tell x that x should
 recommend x

Given the coindexation-based view of Principle B, even if its application is restricted to the distribution of bound variable anaphora, (9) should fail to yield the reading indicated in (10). Note that the embedded object *soko* would be locally bound (by the embedded subject *soko*). If Principle B is a condition on the establishment of Formal Dependency, on the other hand, the availability of reading (10) for (9) is not unexpected since both occurrences of *soko* can Formally Depend upon (the trace of) *Toyota to Nissan* 'Toyota and Nissan', and such Formal Dependencies are not locally established. Note that, if Formal Dependency has to be established locally as in (6), the bound reading is not possible.

3 Principle B effects in the sloppy identity contexts

In section 2, I have argued that Principle B is a condition on the establishment of Formal Dependency. If Formal Dependency is a necessary condition for (certain types) of sloppy identity readings, it follows that the distribution of such readings is constrained by Principle B. In this section, I will argue that such is indeed the case.

3.1 Mix readings

Fiengo & May (1994) (henceforth F&M) provides a detailed account of the following observations made in Dahl (1974) and discussed in Sag (1976) and Dalrymple, Shieber, & Pereira (1991): (11) allows the readings in (13a,b,c) but not the one in (13d), while (12) allows all of the four readings in (14).⁸

- (11) Max said he saw his mother; Oscar did too.
- (12) Max said his mother saw him; Oscar did too.
- (13) a Max₁ said he₁ saw his₁ mother; Oscar₂ said he₁ saw his₁ mother
 b Max₁ said he₁ saw his₁ mother; Oscar₂ said he₂ saw his₂ mother
 c Max₁ said he₁ saw his₁ mother; Oscar₂ said he₂ saw his₁ mother (Mix 1)
 d Max₁ said he₁ saw his₁ mother; Oscar₂ said he₁ saw his₂ mother (Mix 2)
- (14) a Max₁ said his₁ mother saw him₁; Oscar₂ said his₁ mother saw him₁
 b Max₁ said his₁ mother saw him₁; Oscar₂ said his₂ mother saw him₂
 c Max₁ said his₁ mother saw him₁; Oscar₂ said his₂ mother saw him₁
(Mix 1)
 d Max₁ said his₁ mother saw him₁; Oscar₂ said his₁ mother saw him₂
(Mix 2)

For ease of exposition, I will call the third and the fourth readings Mix 1 and Mix 2, respectively. F&M argues that these interpretive possibilities follow from their Dependency Theory. The aspect of their Dependency Theory that is crucial to our discussion at the moment is that a necessary condition for a sloppy identity reading (SR) is the use of a β -occurrence, i.e. a dependent occurrence of a nominal expression.

⁸ Fox (1995) also contains discussion of much relevance in regard to the nature and the analysis of mix readings.

It is pointed out in Hoji (1990), and further argued in Hoji (1998) that comparative ellipsis (CE) in Japanese provides a syntactic context akin to VP ellipsis (and CE) in English, in regard to the distribution of sloppy and strict identity readings. Japanese CE examples with *soko* exhibit the same interpretive possibilities as noted for (11) and (12) above.^{9,10}

- (15) a Seihu-ga [[A-sya-ni yori] sakini] [_{VP} B-sya-ni
government-NOM A-company-DAT than early B-company-DAT
[_{CP} soko-ga soko-no komonbengosi-o uttaeta to] iw]-ase-ta (koto)
it-NOM it-GEN attorney-ACC sued that say-cause-PAST
'The government made Company B say that it had sued its attorney,
earlier than (the government made) Company A (say that it had sued its
attorney).'
- b Seihu-ga [[A-sya-ni yori] sakini] [_{VP} B-sya-ni
government-NOM A-company-DAT than early B-company-DAT
[_{CP} soko-no komonbengosi-ga soko-o uttaeta to] iw]-ase-ta (koto).
it-GEN attorney-NOM it-ACC sued that say-cause-PAST
'The government made Company B say that its attorney had sued it, earlier
than (the government made) Company A (say that its attorney had sued it)'

⁹ Two points of clarification are in order. First, whether or not there is a pause after the adverbial following *yori* 'than' phrase, e.g. [*A-sya ni yori*] *sakini* 'earlier than Company A' in (15), seems to affect the relevant interpretive possibilities of (15) and other comparative ellipsis examples. For this reason, it should be understood henceforth that the pause immediately after ... *yori sakini* is intended in the relevant examples. In some of the examples below, ... *yori sakini* is placed before the matrix subject, so as to avoid the possible complication. Second, *mo* can be attached to *yori*, and its presence can be considered optional for the purposes of the present discussion.

¹⁰ The relevant judgments on the Japanese examples reported in this paper, especially those in this section can be quite subtle. As pointed out in note 3, there are some factors, which I do not address in this paper, that affect the availability of what appears to be bound variable readings. Ueyama (1997a, 1997b) discusses and analyzes them in some depth. While it is not yet entirely clear how such factors can be fully controlled, there are ways in which we can (partially) control them. I have in fact tried to do so by invoking certain complications in examples like (5) and (6) above. We can similarly improve on the examples in this section so that the relevant contrasts may come to be felt more clearly. But the introduction of such complications in turn can make the processing of the relevant examples significantly more difficult, thereby making the relevant judgments more difficult. I have thus decided to present the examples in this section as they appear below, without invoking the complications of the sort introduced in (5) and (6). In my forthcoming works, I make an attempt to present a more comprehensive discussion of the relevant empirical materials and hence of the relevant factors at issue and their analyses.

(15a) allows the two across-the-board readings and Mix 1, but not Mix 2. (15b), on the other hand, allows all of the four readings. The four readings for (15a) and (15b) are given in (16) and (17).

(16) *The readings for (15a) ("*" indicates unavailability)*

- a the government made Company B₁ say that it₁ had sued its₁ attorney, earlier than the government made Company A₂ say that it₁ had sued its₁ attorney
- b the government made Company B₁ say that it₁ had sued its₁ attorney, earlier than the government made Company A₂ say that it₂ had sued its₂ attorney
- c the government made Company B₁ say that it₁ had sued its₁ attorney, earlier than the government made Company A₂ say that it₂ had sued its₁ attorney (Mix 1)
- d *the government made Company B₁ say that it₁ had sued its₁ attorney, earlier than the government made Company A₂ say that it₁ had sued its₂ attorney (Mix 2)

(17) *The readings for (15b) (all readings are available)*

- a the government made Company B₁ say that its₁ attorney sued it₁, earlier than the government made Company A₂ say that its₁ attorney sued it₁
- b the government made Company B₁ say that its₁ attorney sued it₁, earlier than the government made Company A₂ say that its₂ attorney sued it₂
- c the government made Company B₁ say that its₁ attorney sued it₁, earlier than the government made Company A₂ say that its₂ attorney sued it₁ (Mix 1)
- d the government made Company B₁ say that its₁ attorney sued it₁, earlier than the government made Company A₂ say that its₁ attorney sued it₂ (Mix 2)

One may not find this result particularly surprising, given the parallelism between VP ellipsis in English and CE in Japanese, as noted in Hoji (1998), and given the fact that *soko* can be construed as a bound variable. It is noteworthy, however, that the same interpretive possibilities are also observed with *kare*, despite the well-known

generalization that *kare* cannot be construed as a bound variable; see Hoji (1991) and the references therein.¹¹

¹¹ As noted in Hoji (1991), it seems possible for *kare* to be anaphorically related to a *dono*-phrase, such as *dono gakusei* 'which student'.

- (i) a (Hoji 1991: (40c))
 ??Dono hito_i-ga [Mary-ga kare_i-o butta to] itta no
 which person-NOM Mary-NOM him-ACC hit that said
 'Which person_i said that Mary had hit him_i?'
 b ?Dono gakusei-ga kare_i-no sensei-o butta no
 which student-NOM him-GEN teacher-ACC hit
 'Which student_i hit his_i teacher?'

In examples like (ii-a), in contrast to (ii-b), however, it seems more difficult to have the anaphoric relation between the *dono*-phrase and *kare*.

- (ii) a *?[Dono isya_i-ga (itu) kare_i-no kanzya-o misute-temo]
 which doctor-NOM (when) he -GEN patient -ACC abandon-if
 husigi dewanai (zyookyoo-ni natteita).
 wonder is:not (circumstance-DAT became)
 '(It has come to the point where) it would not be surprising no matter which doctor,
 abandons his_i patient (any time).'
 b (?)[Dono isya_i-ga (itu) soitu_i-no kanzya-o misute-temo] husigi dewanai (zyookyoo-ni
 natteita).
 '(It has come to the point where) it would not be surprising no matter which doctor,
 abandons his_i patient (any time).'

The relevant judgments on examples like (i) and (ii) vary a great deal among speakers. (Some speakers allow the anaphoric relation not only between *dono*-phrase and *kare* but also between *dare* 'who' and *kare*.) The unstable status of *kare* is not unexpected, however, given how its modern usage developed, as discussed in Takubo (1996). On the other hand, we seem to detect a clear difference between *kare* and *soko* in examples like the following.

- (iii) a *[John to Bill]_i-ga kare_i-no tomodati-o semeta.
 John and Bill-NOM he-GEN friend-ACC accused
 '[Each of John and Bill]_i accused his_i friend.'
 b [Toyota to Nissan]_i-ga soko_i-no torihikisaki-o semeta.
 Toyota and Nissan-NOM it-GEN business:partner-ACC accused
 '[Each of Toyota and Nissan]_i accused its_i business partner.'
 (iv) a *[John-sae]_i-ga kare_i-no tomodati-o semeta.
 John-even-NOM he-GEN friend-ACC accused
 '[Even John]_i accused his_i friend.'
 b [Toyota-sae]_i-ga soko_i-no torihikisaki-o semeta.
 Toyota-even-NOM it-GEN business:partner-ACC accused
 '[Even Toyota]_i accused its_i business partner.'

- (18) Sensei-wa John-ni yori mo sakini Bill-ni [kare-ga kare-no
teacher-TOP John-DAT than early Bill-DAT he-NOM he-GEN
roomumeito-o nagutta koto]-o mitome-sase-ta.
roommate-ACC hit fact-ACC admit-cause-past
'The teacher made Bill admit [that he had hit his roommate] earlier than
John(-DAT).'
- (19) Sensei-wa John-ni yori mo sakini Bill-ni [kare-no
teacher-TOP John-DAT than early Bill-DAT he-GEN
roomumeito-ga kare-o nagutta koto]-o mitome-sase-ta.
roommate-NOM he-ACC hit fact-ACC admit-cause-past
'The teacher made Bill admit [that his roommate had hit him] earlier than
John(-DAT).'

The four readings for (18) and (19) are given in (20) and (21), respectively.

- (20) *The readings for (18)* ("*" indicates unavailability)
- a the teacher made Bill₁ admit that he₁ had hit his₁ roommate earlier than the teacher made John₂ admit that he₁ had hit his₁ roommate
 - b the teacher made Bill₁ admit that he₁ had hit his₁ roommate earlier than the teacher made John₂ admit that he₂ had hit his₂ roommate
 - c the teacher made Bill₁ admit that he₁ had hit his₁ roommate earlier than the teacher made John₂ admit that he₂ had hit his₁ roommate (Mix 1)
 - d *the teacher made Bill₁ admit that he₁ had hit his₁ roommate earlier than the teacher made John₂ admit that he₁ had hit his₂ roommate (Mix 2)
- (21) *The readings for (19)* (all readings are available)
- a the teacher made Bill₁ admit that his₁ roommate had hit him₁ earlier than the teacher made John₂ admit that his₁ roommate had hit him₁
 - b the teacher made Bill₁ admit that his₁ roommate had hit him₁ earlier than the teacher made John₂ admit that his₂ roommate had hit him₂
 - c the teacher made Bill₁ admit that his₁ roommate had hit him₁ earlier than the teacher made John₂ admit that his₂ roommate had hit him₁ (Mix 1)
 - d the teacher made Bill₁ admit that his₁ roommate had hit him₁ earlier than the teacher made John₂ admit that his₁ roommate had hit him₂ (Mix 2)

If we consider the relevant anaphoric relations above to be all instances of bound variable anaphora, it follows that the generalization that *kare* cannot be construed as a bound variable needs qualification. In the exposition below, however, I will suppress such complications and, simplistically, keep to the assumption that *kare* cannot be construed as a bound variable.

As noted, it is crucial on F&M's account of the contrast between (11) and (12) that pronouns in English can be β -occurrences. Let us assume that Formal Dependency is a necessary condition for Mix readings; see note 1. We can then take the patterns of interpretive possibilities observed in (18) and (19) as indicating not only (i) that CE in Japanese is analogous to VP ellipsis in English, as independently concluded in Hoji (1990, 1998), but also (ii) that *kare* can be a β -occurrence hence can Formally Depend upon another category. The fact that *kare* can be a β -occurrence, giving rise to Mix readings, while being unable to be construed as a bound variable, thus provides support for F&M's (p. 108) conclusion that "the conditions on bound variable anaphora are not coextensive with those on sloppy identity."¹²

3.2 Principle B effects

Let us assume that not only Mix readings but also SRs in general are based on Formal Dependency. Given that Principle B is a condition on Formal Dependency, we then predict that the distribution of SR is constrained by Principle B even when there is no quantificational antecedent involved. This indeed seems to be a correct prediction, as illustrated below.

- (22) a A-sya-ni yori mo sakini seihi-ga
 A-company-DAT than early government-NOM
 B-sya-ni soko-o suisens-aseta (koto).
 B-company-DAT it-ACC recommend-caused
 'The government made Company B recommend it earlier than Company A-DAT.'
 (SR highly marginal to impossible)
- b A-sya-ni yori mo sakini seihi-ga
 A-company-DAT than early government-NOM
 B-sya-ni soko-o suisensita (koto).
 B-company-DAT it -ACC recommended
 'The government recommended Company B-DAT it-ACC earlier than Company A-DAT.'
 (SR highly marginal to impossible)

The examples in (22) must be compared with those in (15) above and (23) below. While the SRs in the former seem highly marginal to impossible, those in the latter seem quite acceptable.

¹² See, however, note 22.

- (23) a A-sya-ni yori mo sakini seihu-ga B-sya-ni [soko-no bengosi]-o
suisens-ase-ta (koto).
'The government made Company B recommend its attorney earlier than
Company A-DAT.'
(SR possible)
- b A-sya-ni yori mo sakini seihu-ga
A-company-DAT than early government-NOM
B-sya-ni soko-no bengosi-o suisensita (koto).
B-company-DAT it-GEN attorney-ACC recommended
'The government recommended Company B-DAT its attorney-ACC earlier
than Company A-DAT.'
(SR possible)
- c A-sya-ni yori mo sakini Tanaka-ga B-sya-ni
A-company-DAT than early Tanaka-NOM B-company-DAT
[_{CP} GM-ga soko-o hihansita to] tutaeta (koto).
GM-NOM it -ACC criticized that told (fact)
'Tanaka told Company B-DAT that GM had criticized it earlier than
Company A-DAT.'
(SR possible)

This observation is significant since examples like (24) allow coreference, unlike their English counterparts.¹³

- (24) a Soko₁-ga soko₁-o suisensita.
'It₁ recommended it₁.'
b Seihu-ga B-sya₁-ni soko₁-o suisensaseta.
'The government made Company B₁ recommend it₁.'

In fact, (22a) allows the strict reading on which the value of *soko* is *Company B*. We observe essentially the same paradigms with *kare*.

- (25) a Mary-ga John-ni yori mo sakini Bill-ni kare-o suisens-asetta (koto).
'Mary made Bill(-DAT) recommend him(-ACC) earlier than John(-DAT).'
(SR highly marginal to impossible)
- b Mary-ga John-ni yori mo sakini Bill-ni [kare-no hon]-o suisens-asetta.
'Mary made Bill(-DAT) recommend his book earlier than John(-DAT).'
(SR possible)

¹³ I will return to the contrast between Japanese and English in section 4.

Thus (25a) does not seem to allow SR, unlike (18), (19) and (25b), despite the fact that examples like (26) allow coreference.

- (26) a Bill₁-ga kare₁-o suisensita.
 'Bill₁ recommended him₁.'
 b Mary-ga Bill₁-ni kare₁-o suisens-aseta.
 'Mary made Bill₁ recommend him₁.'

Just as in the case of (22), (25) allows the strict reading on which the value of *kare* is *Bill*.

Given the assumption that SRs require the Formal Dependency of a nominal upon another, such as *soko* depending on *B-sya* 'Company B' in (22) and (23), and *kare* depending upon *Bill* in (25), the local disjointness effects observed in (22) and (25a) can be taken as confirming evidence for the claim that Principle B is a condition on Formal Dependency, rather than on coindexation. The local disjointness effects in (25a) provide particularly compelling confirmation for this claim, since (i) *kare* does not exhibit local disjointness effects in contexts other than the sloppy identity context, as indicated in (26), and (ii) *kare* cannot be construed as a bound variable.

The claim that Principle B is a condition on Formal Dependency, rather than on coindexation can be supported also by the following observations in English. First, the SR seems possible in (27), i.e. the "I wanted you to vote for your husband" reading.

- (27) I voted for my husband, and I wanted you to [_{VP} *ec*] (too).

By contrast, (28) does not seem to allow the SR, i.e. the "I wanted you to vote for you" reading.

- (28) I voted for me, and I wanted you to [_{VP} *ec*] (too).

Crucially, the examples in (29) below are acceptable, suggesting that the two occurrences of the first person pronoun or those of the second person pronoun can be "coreferential," as they in fact must, due to their lexical properties.¹⁴

- (29) a I voted for me.
b I wanted you to vote for you.

Given the assumption that SRs must be based on Formal Dependency,¹⁵ and given that the establishment of Formal Dependency is subject to Principle B, we can therefore account for the contrast between (27) and (28) in the same way that we have accounted for the contrast between (25a) and (25b) in Japanese. The examples in (29) are acceptable, just as those in (26) are. The relevant anaphoric relation in these examples is that of coreference, hence it does not require the establishment of Formal Dependency. Given that coreference possibilities are not regulated by Principle B, the absence of the local disjointness in (29) and (26) are not unexpected.

3.3 Principle B effects and mix readings

As discussed above, as well as in Hoji (1997a), the SR involved in Mix readings MUST be based on Formal Dependency. More specifically, when (11), repeated

¹⁴ Unlike (29), the examples in (i) are felt to be significantly less acceptable.

- (i) a *I consoled me.
b *I wanted you to console you.

I will turn to the contrast between (29) and (i) in section 4.

¹⁵ It is not quite the case that the SRs are always based on Formal Dependency. As pointed out in Hoji (1997a, 1997c), SRs do arise without involving Formal Dependency. Two types of SRs, one type that is based on Formal Dependency and the other that is not, can, however, be clearly distinguished, as discussed in Hoji (1997a, 1997c). In the latter, but not in the former, Principle B effects as well as other effects associated with necessary conditions for the establishment of Formal Dependency (see note 1 above) are typically missing. For example, it is noted in Hoji (1997c) that not only is (i-a) compatible with the situation depicted in (ii-a) but (i-b) is also compatible with the situation depicted in (ii-b); see also Hoji (1997a: sec. 4).

- (i) a I voted for my husband; and I wanted you to do the same thing.
b I voted for me; and I wanted you to do the same thing.
(ii) a I wanted you to vote for your husband.
b I wanted you to vote for you.

below, yields the Mix 1 reading, the representation of its first conjunct must be such that *he* is Formally Dependent upon *Max*.¹⁶

(11) Max said he saw his mother; Oscar did too.

In Hoji (1998), CE is contrasted with another comparative construction in Japanese, referred to there as comparative deletion (CD). The difference between CE and CD is that while the predicate in the *yori*-clause/phrase is missing in CE, it is not in CD.¹⁷ Thus while CE has the structure of the form [*XP-ni yori*], for example, CD has the structure of the form [*XP-ni V-INFL yori*]. One of the differences between CE and CD noted in Hoji (1998) is that the former yields (genuine) SRs, while the latter does not, as indicated by the contrast in (30).

(30) a [Kanarinokazu-no nihonzin huuu-ni yori mo] sakini
 a:good:number-GEN Japanese couple-DAT than early
 iintyoo-ga nankumika-no amerikazin huuu-ni
 chairperson-NOM some-GEN American couple-DAT
 otagai-o nagusame-saseta (koto).
 each:other-ACC console-caused
 'The chairperson made some American couples console each other earlier
 than a good number of Japanese couples.'

¹⁶ In the terms of F&M, this means that *he* must be a β -occurrence and, roughly, it must be part of the Indexical Dependency of which *Max* is also a part.

¹⁷ The following remarks in the text on the difference between CE and CD are based on Hoji (1998), where a more extensive discussion and the relevant references are provided. Hayashishita (1996) also contains discussion on the differences between the Japanese CE and CD. The choice of the terms comparative ellipsis (CE) and comparative deletion (CD) here is intended to hint at some parallelism between these Japanese constructions and the constructions in English which have been so named in Bach, Bresnan & Wasow (1974). They observe that while CE as in (i) allows an SR, CD as in (ii) does not.

- (i) (=Bach, Bresnan & Wasow 1974:29)
 Comparative Ellipsis : Jack likes more of his children than Bill does.
 (ii) (=Bach, Bresnan & Wasow 1974:30)
 Comparative Deletion : Jack likes more of his children than Bill likes.

Bach, Bresnan & Wasow thus observe that CE does, but CD does not, behave on a par with VP-Deletion in regard to the possibility of SR, just as the contrast we observe between CE and CD in Japanese, as discussed in Hoji (1998).

- b [Kanarinokazu-no nihonzin huuhu-ni *ec* nagusame-saseru-yori mo]
 a:good:number-GEN Japanese couple-DAT console-cause-than
 sakini iintyoo-ga nankumika-no amerikazin huuhu-ni
 early chairperson-NOM some-GEN American couple-DAT
 otagai-o nagusame-saseta (koto).
 each:other-ACC console-caused
 'The chairperson made some American couples console each other earlier
 than (he) made many Japanese couples console *ec*.'

The SR, that is, the reading "the chairperson made some American couples console each other earlier than {he/she} made a good number of Japanese couple console each other (i.e. the reciprocal consoling by the husband and the wife for each couple)" is possible for (30a), but not for (30b). Based on this and other observations, it is concluded in Hoji (1998) that CE does, but CD does not, yield (genuine) SRs.¹⁸

According to the proposal there, the SR in (31) below is due to the coreference between *A-sya₁* and *ec₁*, and has nothing to do with Formal Dependency.¹⁹

- (31) Seihu-ga [A-sya₁-ni *ec₁* suisens-ase-ru yori mo sakini] B-sya₂-ni soko₂-o
 suisens-ase-ta (koto).
 'The government made Company B₂ recommend it₂ earlier than (the
 government) made Company A₁ recommend *ec₁*.'

¹⁸ The English rendition given for *otagai* in (30) is just for the ease of exposition. Hoji (1997d) argues, contrary to the widely-held assumption, that *otagai* is not a local reciprocal anaphor, based on the observations that can be characterized roughly as follows:

- The "antecedent" of *otagai* need not be in the local domain of the latter;
- Otagai* need not be c-commanded by its "antecedent";
- Split antecedence is possible for *otagai*;
- Familiar Weak Crossover (WCO) effects are observed when bound variable anaphora is at stake;
- WCO effects are observed in the sloppy identity context.

¹⁹ Not all instances of SRs in a CD can be regarded as being due to coreference. The instances of SRs in CD that are NOT due to coreference are, in the terms of Hoji (1998), based on the concept use, rather than the referential use, of a null argument. Crucially, however, no instances of SRs in CDs are based on Formal Dependency. In our present discussion, we discuss only the SRs in a CD based on the referential use of a null argument. This, however, does not affect the point of contention here in any crucial way. Hoji (1997a) also contains relevant discussion.

The SR in (31) is due to the coreference between $A\text{-}sya_1$ and ec_1 on the one hand, and that between $B\text{-}sya_2$ and $soko_2$ on the other. Since Formal Dependency is not involved, Principle B is not violated here.

Given that the SR involved in Mix readings must be based on Formal Dependency, and given that the SRs found in CDs, such as (31), are not based on Formal Dependency, we predict that CD examples do not give rise to Mix readings. This is a correct prediction, as indicated by the unavailability of the Mix readings in (32) and (33).

- (32) Seihu-ga [A-sya-ni *ec* happyoos-ase-ru]-yori mo sakini B-sya-ni soko-ga soko-no syatyoo-no siyuubutu-da to happyoos-ase-ta (koto).
 'The government made Company B announce that it is its president's private possession earlier than (the government) made Company A-DAT announce *ec*.'
- (33) Mary-ga [John-ni *ec* iw-ase-ru]-yori mo sakini Bill-ni kare-ga kare-no titioya-no kookeisya-da to iw-ase-ta (koto).
 'Mary made Bill(-DAT) declare that he is his father's successor earlier than (Mary) made John(-DAT) declare *ec*.'

Recall that I have reported in section 3.2 that the SR in (22) and (25a) are highly marginal to impossible, hinting that it might be felt to be not totally impossible. I suggest that such marginal acceptability of the SR is, at least in part, due to the marginal possibility of analyzing a CE as an instance of CD, despite the absence of the overtly realized predicate in the complement clause of *yori* 'than'; see note 10. For example, to the extent that the SR in (22a) is felt to be marginally possible, I suggest that it is in part due to the marginal possibility of "reanalyzing" (22a) as (31). I repeat (22a) and (31), for convenience.

- (22) a Seihu-ga A-sya-ni yori mo sakini B-sya-ni soko-o suisens-ase-ta (koto).
 'The government made Company B recommend it earlier than Company A-DAT.'
 (SR highly marginal to impossible)
- (31) Seihu-ga [A-sya₁-ni ec_1 suisens-ase-ru yori mo sakini] B-sya₂-ni soko₂-o suisens-ase-ta (koto).
 'The government made Company B₂ recommend it₂ earlier than (the government) made Company A₁ recommend ec_1 .'

We have observed that CDs do not give rise to Mix readings. Given that the marginal possibility of the SR in the CE in (22a) is due to its “reanalysis” as a CD as in (31), it follows that, if we impose a Mix reading on our CE examples, we can preclude the possibility of the “reanalysis” of a CE as a CD, thereby forcing the relevant SR to be based on Formal Dependency. Since Formal Dependency is subject of Principle B, we therefore predict that Mix readings are not possible in CE examples in which the relevant Formal Dependency is local.

This indeed seems to be a correct prediction, as indicated by the unavailability of the Mix readings in (34) and (35), cf. (22a) and (25a).²⁰

- (34) Seihu-ga A-sya-ni yori mo sakini B-sya-ni soko-o soko-no syatyoo-no siyuubutu-da to happyoos-ase-ta (koto).
 ‘The government made Company B announce it to be its president’s private possession earlier than Company A-DAT.’
- (35) Mary-ga John-ni yori mo sakini Bill-ni kare-o kare-no titioya-no kookeisya-da to iw-ase-ta (koto).
 ‘Mary made Bill(-DAT) declare him(-ACC) to be his father’s successor earlier than John(-DAT).’

In order for (34) and (35) to yield the Mix 1 reading, *soko-o* and *kare-o* must be Formally Dependent upon *B-sya-ni* and *Bill-ni*, respectively; but such dependency would be local, violating Principle B.

As expected, if the relevant locality is removed, as in (36) and (37), the Mix 1 reading becomes available; see also (15a) and (18) given earlier.

²⁰ I assume that the possibility of (34), for example, to have the across-the-board sloppy reading (in addition to the across-the-board strict reading), depends upon the possibility of the “reanalysis” of (34) as an instance of a CD as in (i), and upon the possibility of the across-the-board sloppy reading for (i).

- (i) Seihu-ga [[A-sya-ni *ec* happyoos-aseru] yori] mo sakini B-sya-ni soko-o soko-no syatyoo-no siyuubutu-da to happyoos-ase-ta (koto).
 ‘The government made Company B announce it to be its president’s personal property earlier than (the government) made Company A announce *ec*.’

The across-the-board sloppy reading for (i) can be considered as analogous, though not quite identical, to the across-the-board sloppy reading for (ii).

- (ii) John claimed that he had cleaned his room; and Bill claimed the same thing.

See Hoji (1997a) for further discussion.

- (36) Seihu-ga A-sya-ni yori mo sakini B-sya-ni [soko-ga soko-no syatyoo-no siyuubutu-da to] happyoos-ase-ta (koto).
 'The government made Company B announce that it is its president's private possession] earlier than Company A-DAT.'
- (37) Mary-ga John-ni yori mo sakini Bill-ni [kare-ga kare-no titioya-no kookeisya-da to] iw-ase-ta (koto).
 'Mary made Bill(-DAT) declare that he is his father's successor earlier than John(-DAT).'

Here, in harmony with the interpretive patterns observed in section 3.1, only the Mix 1, but not Mix 2, reading seems possible.²¹ If we embed the first instance of *soko* in

²¹ Due to space limitation, it is not possible to present here a fuller discussion of the nature and the account of the Mix readings. Sag's (1976: 137ff) account of the unavailability of Mix 2 readings in (11), repeated below as (i), in effect makes a crucial reference to the fact that *he* c-commands *his*. In example (12), repeated below as (ii), this c-command relation is removed. As noted earlier, (ii) allows both Mix 1 and Mix 2 readings.

- (i) Max said he saw his mother; Oscar did too.
 (ii) Max said his mother saw him; Oscar did too.

F&M's account of the relevant interpretive possibilities, in effect, also makes crucial use of the c-command relation, although their Dependency Theory does not make an explicit reference to it. Given that Formal Dependency is established based on c-command, the SR in (iii) below, which F&M takes as crucial evidence for dissociating the structural conditions on the distribution of bound variable anaphora and those on the distribution of sloppy identity readings, cannot be based on Formal Dependency, as is in fact suggested in Hoji (1998: sec. 4.2); see also Tomioka (1996) for much relevant discussion on the nature of the SR in examples like (iii).

- (iii) (F&M p. 108, "adapted from examples due to M. Wescoat, cited in Dalrymple, Shieber, & Pereira 1991")
 The policeman who arrested John read him his rights, and the one who arrested Bill did too.

Hence we predict that examples of the structure as in (iv) do not give rise to Mix readings.

- (iv) The policeman who arrested John said that he had hit his roommate; and the one who arrested Bill did too.

The demonstration of how this prediction is borne out will have to be a topic of a separate work, but most speakers seem to find Mix 1 in (iv) much more difficult than that in (v), if not simply impossible.

- (v) John said that he had hit his roommate; and Bill did too.

The relevant Japanese data also confirm that c-command is a necessary condition for the establishment

(36) and *kare* in (37), then, again in harmony with the interpretive patterns observed in section 3.1, both Mix 1 and Mix 2 readings seems to become available, as in the case of (15b) and (19). Similarly the “removal” of c-command in (35), as in (38), seems to make both Mix readings possible.

- (38) Mary-ga John-ni yori mo sakini Bill-ni kare-no sinyuu-o kare-no titioya-no kookeisya-da to iw-ase-ta (koto).
 ‘Mary made Bill(-DAT) declare his best friend to be his father’s successor earlier than John(-DAT).’

Suppose that the CEs in (34) and (35) are “reanalyzed” as CDs as in (39) and (40), respectively.

- (39) Sei-hu-ga [A-sya-ni ec happyoos-aseru yori] mo sakini B-sya-ni soko-o soko-no syatyoo-no siyuubutu-da to iw-ase-ta (koto).
 ‘The government made Company B announce it to be its president’s private possession earlier than Company A-DAT.’
- (40) Mary-ga [John-ni ec iw-ase-ru yori] mo sakini Bill-ni kare-o kare-no titioya-no kookeisya-da to iw-ase-ta (koto).
 ‘Mary made Bill(-DAT) declare him(-ACC) to be his father’s successor earlier than John(-DAT).’

These CD examples allow the strict readings, for example, with *B-sya-ni* and *Bill-ni* being coreferential with *soko-o* and *kare-o*, respectively; see note 20. Note that the

of Formal Dependency and hence for the availability of Mix readings. The examples in (vi) thus do not seem to yield Mix readings, in contrast to (37) for example.

- (vi) a Sensei-wa [_{NP} _{IP} ec John-o osieta] hito]-ni yori mo sakini [_{NP} _{IP} ec Bill-o teacher-TOP John-ACC taught person-DAT than early Bill-ACC osieta] hito]-ni [kare-ga kare-no roommate-o nagutta to] mitome-sase-ta.
 taught person-DAT he-NOM he-GEN roommate-ACC hit that admit-cause-past
 ‘The teacher made [the person who taught Bill] admit [that he had hit his roommate] earlier than [the person who taught John](-DAT).’
- b Sensei-wa [_{NP} _{IP} ec John-o osieta] hito]-ni yori mo sakini [_{NP} _{IP} ec Bill-o teacher-TOP John-ACC taught person-DAT than early Bill-ACC osieta] hito]-ni [kare-no roommate-ga kare-o nagutta to] mitome-sase-ta.
 taught person-DAT he-GEN roommate-NOM he-ACC hit that admit-cause-past
 ‘The teacher made [the person who taught Bill] admit [that his roommate had hit him] earlier than [the person who taught John](-DAT).’

representations that correspond to such readings do not violate Principle B since Formal Dependency is not involved, just as in the CD example in (31) above. Mix readings, by contrast, are not possible in (39) and (40), as expected. The unavailability of the Mix readings in the CD examples in (39) and (40), on the other hand, is due to the properties of CDs, rather than being due to Principle B. Recall that the CD counterparts of (36) and (37), as given in (32) and (33) above, also cannot yield Mix readings, despite the absence of the relevant locality there.

To summarize, given the conclusion in Hoji (1998), in terms of the discussion here, that the SR in CD cannot be based on Formal Dependency, it follows that the CD examples cannot give rise to Mix readings, since Mix readings require an SR that is based on Formal Dependency. Hence, by exclusively considering the availability of Mix readings, we can ensure that we are checking the availability of the SR that is based on Formal Dependency, not the SR that is based on coreference. In other words, by exclusively considering the availability of Mix readings, we can preclude the marginal possibility of the "reanalysis" of a CE as a CD, thereby making it possible to conduct a more reliable experiment that is intended to examine the effects of Principle B in the CE examples; see note 10. We have in fact observed that Principle B effects are clearly detected (more clearly than in (22) and (25a)) if we impose Mix readings on the relevant examples; see (34) and (35). I take the observations in this subsection as confirming evidence that Principle B is a condition on Formal Dependency.

3.4 Summary

In section 3.1, it was demonstrated that sloppy identity readings (SRs) obtain not only with *soko*, which can be construed as a bound variable, but also with *kare*, which, as it is generally understood, fails to be construed as a bound variable. This suggests that the conditions on the distribution of bound variable anaphora and those on the distribution of SRs are not coextensive, confirming the claim made in F&M.²² In section 3.2, evidence was presented indicating that Principle B restricts the

²² It should be noted, however, that the argument put forth in F&M and the one presented above for the claim that the conditions on the distribution of bound variable anaphora and those on the distribution of SRs are not coextensive are of different types. F&M's evidence for dissociating bound variable anaphora and SRs has to do with the structural relations between the bindee and the binder, as the terms "bindees" and "binders" are customarily understood in the discussion of bound variable anaphora and SRs. The evidence presented above, on the other hand, has to do with (presumably, the content of) the relevant nominals that are crucial in obtaining bound variable construal or an SR.

distribution of SRs not only in examples with *soko* but also in those with *kare*. Recall the conclusion in section 2 that Principle B is a condition on the establishment of Formal Dependency. Given that the distribution of SRs is regulated by Principle B, it seems reasonable to conclude that Formal Dependency is a necessary condition not only for bound variable anaphora but also for (certain types of) SRs. The fact that *kare* fails to be construed as a bound variable and yet can yield SRs, as long as it does not violate Principle B, supports this conclusion. Recall that examples like *kare-ga kare-o suisensita* 'he recommended him' readily allow coreference; see Hoji (1995) and the references cited there. The observations in section 3.2 therefore constitute further evidence for the claim that Principle B is a condition on Formal Dependency, rather than on coindexation, irrespective of whether coindexation is necessarily interpreted as bound variable anaphora. Confirming evidence for this claim was given in section 3.3, where Principle B effects in the context of Mix readings are considered.

4 "Coreference residue of Principle B"

I have argued that Principle B is a condition on Formal Dependency and, as argued in Reinhart (1983: Ch. 7), does not regulate the possibilities of coreference. Given that coreference possibilities are not regulated by Principle B, the question arises as to why coreference in (41) is strongly disallowed, in contrast to its Japanese analogue in (42), which readily allows coreference; cf. Hoji (1995) and the references given there.

- (41) It recommended it.
 (42) Soko-ga soko-o suisensita.

One might attribute the impossibility of the coreference in (41) to factors other than Principle B. Reinhart's (1983) pragmatic account, which may be considered as the representative of such an approach, faces problems of various sorts, as discussed in Higginbotham (1985) and Lasnik (1989).

Let us thus pursue the possibility that the impossibility of coreference in (41) is indeed due to Principle B, as argued in Hoji (1995). Principle B is argued to be on Formal Dependency and the input to the Formal Dependency System is assumed to be generated by operations that are based on formal agreement features (in addition to the concatenation operation "Merge"), i.e. the operations in the Computational

System in the sense of Chomsky's recent works. This in turn, given that the impossibility of coreference in (41) is indeed due to Principle B, means that in the LF representation of (41), unlike in the case of (42), Formal Dependency must be "forced" as the result of the presence of formal agreement features, thereby violating Principle B. In the terms of the present discussion, we can rephrase the suggestion made in Hoji (1995) as follows. The formal agreement features have to be licensed in some way in the Computational System, such as by being raised to appropriate positions. If a nominal consists solely of formal agreement features, then this operation results in a structure that in effect "forces" Formal Dependency in the local domain in the case of the derivation of the LF representation such as for (41), for reasons yet to be understood.²³ Given that *soko* does not consist solely of formal agreement features, as I argued elsewhere (Hoji 1995, 1997a, 1997b), the LF representation of (42) does not "force" Formal Dependency, thereby not making it subject to Principle B. This account of the contrast between (41) and (42) fits nicely in the organization of grammar given below, proposed in Hoji (1997a, 1997b), although serious questions still remain.²⁴

Computational System == >	Formal Dependency System == >	Other "systems" of grammar, == > discourse, etc.	so-called "meanings"
---------------------------	-------------------------------	--	----------------------

It is also argued in Hoji (1995) that the status of (43a) and (44a) has nothing to do with Principle B.²⁵

²³ The relevant process involved here may be closely related, if not identical, to that involved in the case of cliticization, as suggested to me by Joseph Emonds (p.c. 1990).

²⁴ Some remarks for clarification are in order. First of all, "systems" are not meant to be levels. Rather, a "system" here is meant to be a certain set of operations. More specifically, Merge and Agreement-induced operations constitute the Computational System and the establishment of Formal Dependency, Quantifier Raising (or possibly, Constituent Raising) constitute the Formal Dependency System; see also note 1. I assume an LF representation to be a P-marker, derived by Merge and other operations in the Computational System and the Formal Dependency System, plus FDs (Formal Dependencies).

²⁵ I maintain, as in Hoji (1997a, 1997b), that the contrast between (i-a) and (i-b) is to be accounted for in the same way as the contrasts in (43) and in (44).

- (i) a *I consoled me.
b I voted for me.

- (43) a *Kare₁-ga kare₁-o nagusameta (koto).
 'He₁ consoled him₁.'
 b ?Kare₁-ga kare₁-o eranda (koto).
 'He₁ elected him₁.'
- (44) a *John₁-ga John₁-o nagusameta (koto).
 'John₁ consoled John₁.'
 b ?John₁-ga John₁-o eranda (koto).
 'John₁ elected John₁.'

It is further argued there that the coreference is possible in (45) because *HIM* consists not only of grammatical ϕ -features (i.e. instances of formal agreement features) but also of some content under N, which presumably has to do with demonstration of some sort, and hence does not undergo the process described above.²⁶

- (45) John₁ recommended HIM₁.

When Formal Dependency is required as in (46a) under the interpretation in which *HIM* is construed as bound to *no linguist*, Principle B is violated, even when the Computational System does not "feed" the relevant Formal Dependency.

- (46) a *No linguist₁ recommended HIM₁ for that lucrative project.
 b No linguist₁ recommended HIS₁ student for that lucrative project.

Principle B effects in Japanese observed in (6), for example, are then analogous to Principle B effects observed in (46a).

To summarize, local disjointness effects that have been considered in various works in the literature as effects of Binding Principle B must be understood as arising from different sources. The local disjointness effects in (41) is, so to speak, due to

²⁶ In Hoji (1995: sec 3) it is suggested, drawing in part from Postal (1969), that the internal structures for *it*, *HIM* and *soko* are as in (i).

- (i) a *it*: [_{DP} [_D F1]] (or simply [_{DP} F1]) (F1 = ϕ -features)
 b *HIM*: [_{DP} [_D F1] [_{NP} F2]] (F1 = ϕ -features, F2 = the features relevant for stress/focus/etc.)
 c *soko*: [_{NP} [_{DP} so] [_N ko]]

Hoji (1995: sec. 3) also contains some discussion on the differences in the relevant respect among *it*, *'im*, *him* and *HIM*.

the conspiracy between the Computational System and Formal Dependency System. The local disjointness effects in (46a) as well as in the relevant Japanese examples that exhibit Principle B effects are due to Formal Dependency System. Finally, the local disjointness effects in (43a) and (44a) are due to factors outside the two formal systems of the human language faculty.

We thus account not only for the contrast between English examples of the form in (41) and their Japanese counterparts such as (42), plus many empirical materials surrounding this contrast, but also for the differences in the degrees of robustness in the speakers' judgments on examples of the forms in (47), (48) and (49).

- (47) a *it_i V-ed it_i
 b *he_i V-ed 'im_i
- (48) a *Q-NP₁ V-ed HIM₁
 b *Q-NP₁-ga soko₁-o V
- (49) a He_i voted for HIM₁.
 b *He_i consoled HIM₁.
 c John_i-ga John_i-o suisensita.
 'John_i elected John_i.'
 d Soko_i-ga soko_i-o eranda.
 'It_i recommended it_i.'
 e *John_i-ga John_i-o nagusameta.
 'John_i consoled John_i.'

The judgments on the coreference possibility in examples like (49) fluctuate widely, from perfect to highly marginal, and are affected a great deal by the choice of the predicate as well as pragmatic contexts in which they are used; see Hoji (1995). By contrast, the judgements on the local disjointness effects in (47) and (48) are much more uniform and robust.

5 Conclusion

I have presented arguments that Principle B is a condition on Formal Dependency. The initial argument for it, given in section 2, is based on the availability of bound variable construal in the local context, as in (9), in contrast to (6). Further argument is provided in section 3, based on the observation that "local disjointness effects" are observed in the sloppy identity context. The observation there is significant for two

reasons. First, as indicated in Hoji (1995), coreference relations are not subject to the "local disjointness," confirming Reinhart's conclusion that Principle B is not a condition on coreference. Second, the "local disjointness effects" in the sloppy identity context are observed in examples with *kare*, despite the fact that *kare* in general fails to be construed as a bound variable. Note that such "local disjointness effects" could not be accounted for if Principle B were understood as a condition on the distribution of coindexation, even with its application being restricted, as in Reinhart (1983: Ch. 7), to cases of bound variable anaphora.

Given that Principle B is a condition on Formal Dependency, hence not regulating coreference, the recurrent problem arises, as has plagued any version of Reinhart's (1983: Ch. 7) view of Principle B, namely, how to account for the "coreference residue of Condition B." In section 4, I have argued that such effects observed in English are crucially related to the fact that English personal pronouns consist solely of grammatical ϕ -features (i.e. instances of formal agreement features) and that the relevant contrast between English and Japanese can be attributed to the Japanese nominals such as *kare* and *soko* not consisting solely of grammatical ϕ -features, unlike English personal pronouns. This account can be regarded as an immediate consequence, if we accept, as I in fact do, the essentials of the proposals made in Fukui (1986) and Kuroda (1988), namely, that Japanese does not have formal agreement features; see Hoji (1996: sec. 3).²⁷ The absence of formal agreement features in Japanese has been argued to account for the absence of a wide range of properties in Japanese, including the (overt) WH-movement, subject-verb agreement and the uniqueness of the subject of a clause. Given the account suggested in section 4, we can now add to this list a seemingly quite unrelated property in Japanese, namely that it does not, unlike English, exhibit the Principle B effects induced in part by an operation having to do with formal agreement features.²⁸

²⁷ Fukui (1986) expresses this essential idea in terms of the absence of functional categories and Kuroda (1988) in terms of the optionality of Agreement.

²⁸ Hoji (1997b) presents a slightly more articulated version of the analysis here of the three sources of local disjointness and discusses some of its problems. Hoji (forthcoming) is to offer a more comprehensive view of the general proposal that underlies the research presented here. The relations among Formal Dependency, Higginbotham's (1983, 1985) Linking and Fiengo & May's (1994) Indexical Dependency will also be addressed in that work.

References

- Bach, Emmon, Joan Bresnan & Tom Wasow. 1974. "Sloppy identity": an unnecessary and insufficient criterion for deletion rules. *Linguistic Inquiry* 5. 609-14.
- Chomsky, Noam. 1981. *Lectures on government and binding*. Dordrecht: Foris Publications.
- Dahl, Östen. 1974. How to open a sentence: abstraction in natural language. *Logical grammar reports* 12. University of Göteborg.
- Dalrymple, Mary, Stuart Shieber, & Fernando Pereira. 1991. Ellipsis and higher-order unification. *Linguistics and Philosophy* 14. 399-452.
- Evans, Gareth. 1980. Pronouns. *Linguistic Inquiry* 11. 337-362.
- Fiengo, Robert & Robert May. 1994. *Indices and identity*. Cambridge, Mass.: MIT Press.
- Fox, Danny. 1995. Locality in variable binding. To appear in Barbosa, Fox, Hagstrom, McGinnis & Pesetsky (eds) *Is the Best Good Enough*. Cambridge, Mass.: MIT Press and MITWPL.
- Fukui, Naoki. 1986. A theory of categories projection and its applications. Dissertation. Cambridge, Mass.: MIT.
- Hayashishita, J.-R. 1996. Interpretation of ellipsis in Japanese comparative construction. Manuscript. University of Southern California.
- Heim, Irene. 1992. Anaphora and semantic interpretation: a reinterpretation of Reinhart's approach. Manuscript. Cambridge, Mass.: MIT.
- Higginbotham, James. 1983. Logical form, binding, and nominals. *Linguistic Inquiry* 14. 395-420.
- Higginbotham, James. 1985. On semantics. *Linguistic Inquiry* 16. 547-93.
- Higginbotham, James. 1992. Anaphoric reference and common reference. Manuscript. Cambridge, Mass.: MIT.
- Hoji, Hajime. 1990. Theories of anaphora and aspects of Japanese syntax. Manuscript. USC.
- Hoji, Hajime. 1991. *Kare*. In R. Ishihara and Carol Georgopolous (eds) *Interdisciplinary Approaches to Language: in Honor of Prof. S.-Y. Kuroda*. Dordrecht: Kluwer. 287-304.
- Hoji, Hajime. 1995. Demonstrative binding and principle B. *NELS* 25. 255-271.
- Hoji, Hajime. 1996. A review of *Japanese syntax and semantics* by S.-Y. Kuroda. To appear in *Language*.
- Hoji, Hajime. 1997a. Sloppy identity and Formal Dependency. *WCCFL* 15. 209-223.
- Hoji, Hajime. 1997b. Formal Dependency, organization of grammar and Japanese demonstratives. In N. Akatsuka, H. Hoji & S. Iwasaki (eds) *Japanese/Korean Linguistics*. Vol. 7. Stanford: CSLI.
- Hoji, Hajime. 1997c. Experiments in linguistic science: the null argument anaphora, VP ellipsis and other "deep/surface anaphors." To appear in Andy Barss & Terence Langendoen (eds) *Explaining Linguistics*. Blackwell.
- Hoji, Hajime. 1997d. *Otagai*. Manuscript. USC (presented at WCCFL 16, 3/2/97, U. of Washington).
- Hoji, Hajime. 1998. Null object and sloppy identity in Japanese. *Linguistic Inquiry* 29.1.
- Hoji, Hajime. forthcoming. *Formal Dependency and organization of grammar*. Cambridge, Mass.: MIT Press.
- Kuroda, S.-Y. 1988. Whether we agree or not: a comparative syntax of English and Japanese. *Linguisticae Investigationes* 12. 1-47.

- Lasnik, Howard. 1989. On the necessity of Binding Conditions. In *Essays on Anaphora*. Dordrecht: Kluwer. 149-167.
- Postal, Paul. 1969. On So-Called "Pronouns" in English. In D. A. Reibel & S. A. Schane (eds) *Modern Studies in English*. Englewood Cliffs, New Jersey: Prentice-Hall. 201-224.
- Reinhart, Tanya. 1983. *Anaphora and semantic interpretation*. London: Croom Helm.
- Sag, Ivan. 1976. Deletion and logical form. Dissertation. Cambridge, Mass.: MIT.
- Takubo, Yukinori. 1996. On the Semantics and Semantic Changes of the Distal Demonstrative *Kare* in Japanese. Manuscript, Kyushu University. (presented at the Workshop on Demonstratives in Japanese and Korean, 11/9/96, UCLA)
- Tomioka, Satoshi. 1996. On the mismatch between variable binding and sloppy identity. *WCCFL 14*. 541-556.
- Ueyama, Ayumi. 1997a. Scrambling in Japanese and bound variable construal. Manuscript. USC.
- Ueyama, Ayumi. 1997b. Two types of dependency. Manuscript. USC.

Anaphora and the Uniformity of Grammar

Jan Koster

1 Introduction

Modern generative grammar has a tradition of at least 40 years. Within this tradition, emphasis and focus have not always been the same. As a result of the introduction of trace theory in Chomsky (1973), for instance, many linguists sought to explain "movement" constructions and phenomena of bound anaphora in terms of the same concepts. This perspective is still present in the Pisa lectures (Chomsky 1981), where bound anaphors such as *himself* and the traces of NP-movement obey the same principle A of the classical binding theory:

- (1) A An anaphor is bound in its governing category.
- B A pronoun is free in its governing category.
- C An R-expression is free.

This theory presupposes a taxonomy of NPs, according to which both English reflexives and the traces of NP-movement are assigned the same status as anaphors. From the point of view in question, the principles of grammar are relatively uniform across the various kinds of grammatical dependencies. This uniformity idea has been further developed and emphasized in Koster (1978) and (1987), where the notion of movement rules is entirely given up in favor of more abstract principles that govern both anaphoric constructions and movement constructions. Apart from certain similarities in properties, the uniformity hypothesis has been inspired by the idea of structure-preservingness, as it has been developed since Emonds (1970).

Take a typical class of movements, such as in the constructions involving Wh-movement (see Chomsky 1977). Wh-movement moves an XP to the Spec of CP and leaves a trace, forming a link of a chain that way. Movement seems entirely

superfluous to create such a link, because it has always been possible (abstracting away from earlier terminology) to fill Specs on the basis of X-bar schemas only. It would be odd to make a special exception for the Spec of CPs, by preventing them to be filled before movement. Similarly, assuming that traces are just empty categories, they are available for free by making category expansion and lexicalization optional, a necessary assumption anyway. Needless to say, a special chain formation algorithm (as some kind of notational variant of movement) would be entirely superfluous. Assuming that local property sharing between categories is the essence of grammatical relations (as described in Koster 1987), a "trace" is sharing (lexical) content with its antecedent in exactly the same way as a reflexive shares referential, and possibly other, properties with its antecedent.

It is unfortunate from the present perspective, that the uniformity ideal of Chomsky (1973) is given up in recent studies such as Chomsky (1995). I have not been able to find a single convincing argument for the distinction between "merge" and "move". Movement, in my view, remains as superfluous as it has always been. Particularly, the impossibility to formulate structure-preservingness in the framework of Chomsky (1995: ch.4) seems a questionable feature of the theory in question. Apart from head movement, for which I made an exception in Koster (1978), moving maximal projections (no matter how defined) seem to land just as much in positions definable by "merge" (or X-bar theory, or whatever) as before.

Another feature of the framework sketched in Chomsky (1995: ch.4) is the tendency to relegate most or even all aspects of anaphora to the interfaces. This is a further step away from the uniformity hypothesis and therefore undesirable on general grounds (assuming that we want to conform to the normal scientific practice to maximize the scope of principles and laws).

So, in this article I will assume the archconservative position that the uniformity perspective of Chomsky (1981) (and Koster 1978 and 1987) is the correct approach and that the anaphoric systems of most languages share certain core properties with movement constructions. This is not to deny, of course, that anaphoric systems pose certain problems to a purely configurational approach. I will nevertheless assume that certain core properties (certain forms of prominence, like c-command, and locality) are largely uniform across the domains of anaphoric and movement constructions.

According to the most popular alternatives, anaphoric relations are a matter of argument structure or theta role relations. That kind of approach is also problematic because it makes the configurational similarities with movement accidental, not unlike what happens in Chomsky's approach, in which movement (instead of anaphora) is dropped from the uniformity perspective. It seems to me that the classical arguments

against argument-based chain formations apply just as well to anaphoric chains. According to the classical arguments, movement is not a matter of argument structure because there are chains of elements that have no relation in terms of argument structure:

- (2) a *They* seem [*t* to go].
 b *John* was believed [*t* to go].

In neither case, the moved elements are co-arguments of their traces. Antecedent-anaphor combinations are found in very similar structures:

- (3) a *They* seem to *each other* [*t* to go].
 b *John* believes [*himself* to go].

Like in (2), these examples involve chains of elements that are not co-arguments. *Prima facie* at least, such examples form a powerful argument against an approach of anaphora solely in terms of argument structure. The only way out for such approaches, as far as I know, is to assume that antecedent and anaphor in (3) are co-arguments of the complex predicates *seem-to-go* and *believe-to-go*. Such an approach strikes me as being very artificial and empirically wrong. The subject of *seem* in (3a) is not an argument position at all. Similarly, there is plenty of evidence that the embedded subject position is not an inherent argument position, and therefore not an inherent co-argument either:

- (4) a John wants [*it* to snow].
 b Mary believed [*there* to be a man in the yard].

Example (4a) involves the unique weather *it*, which is hardly an argument and never a co-argument. Sentence (4b) has the non-argument *there* as subject. In short, such examples are just anomalies for an argument-structure-based theory of anaphora. Since there are also problems for a purely configurational theory of anaphora, the best approach, ultimately, would be to see the properties of anaphora as the intersection of a configurational core theory and certain interface theories (in the sense of Chomsky 1995).

Due to a lack of space, before I move on to a specific new idea, I will only give a brief summary of my further background assumptions, referring the reader to Koster (1987).

The main core properties shared by movement chains and anaphoric chains are prominence of the antecedent (c-command) and locality. Although c-command will do for many anaphoric configurations, there are certain well-known anomalies, which I will not go into here. As for locality principles, I assume the following:

(5) *Locality*

a [β ... δ ...]

b [β ... ω ... δ ...]

The locality condition for movement has the domain definition as given in (5a). It says that a dependent element δ (a trace in this case) must be bound in domain β (β being a maximal projection). This is the Bounding Condition replacing Subadjacency in Koster (1978, 1987), related to certain later formulations of the ECP and the blocking categories of Chomsky (1986).

For anaphoric relations, this basic locality domain only has to be minimally modified, namely by adding the opacity factor ω (like Subject or Tense). Seen from this perspective, the locality condition for anaphora is a more permissive variant of the basic locality condition for movement (see Koster 1987 for further details).

A next assumption I am making here is the one introduced above:

(6) *Thesis of Grammatical Uniformity*

Movement chains and anaphoric chains have the same core properties.

This is further substantiated by what I assume is the core rule of grammar (see Koster 1987 for a more elaborate account):

(7) *Core Rule of Grammar*

In a local domain, dependent elements and their antecedents may share any property necessary.

This rule entails that chain formation for anaphors and traces works exactly the same.¹ In both cases, it is a manifestation of the general property sharing allowed in local contexts. By way of illustration, consider the following examples:

- (8) a *Whom* did you see *t* ?
 b *Mary* was arrested *t*.
 c *John* saw *himself*.

In (8a) and (8b), the argument status assigned to the trace position is "shared" with the lexical content of the antecedents. In (8c), the reflexive *himself* shares its referential properties with the antecedent *John*. All these structures can be base-generated (by "merge", if you like) and optional expansion (lexicalization). I do not know of any good reasons to deviate from these simple assumptions by invoking complicated extra machinery like movement rules. Chain formation is just an instance of the much more general property sharing mechanism (7).

2 Some problems of the standard binding theory

Apart from the general properties of a configurational approach to anaphora, there are some more specific problems with the standard binding theory (1), both of a conceptual nature (9) and of an empirical nature (10):

- (9) *Conceptual*:
 a principle A near superfluous (given (7))
 b principle B: negative principles unusual
- (10) *Empirical*:
 a overlap anaphors and pronominals in local domain
 b differences among languages
 c short vs. long forms

¹ "Share property" means that in a syntactic dependency relation, all features of the dependent element are available for the antecedent and the other way around. Old-fashioned agreement rules are an instantiation of this, but also "movement" (sharing of lexical properties between head and tail of a chain) and anaphora (sharing of intended coreference). In the unmarked case, the local domain is just the minimal XP containing the dependency. In certain cases, marked extensions are possible, such as the opacity factor "tense" for anaphora (see Koster 1987 for details).

Since in general, according to (7), a dependent element (like an anaphor or a trace) can only be saved by a local antecedent to share the missing properties with, a specific binding condition like principle A seems superfluous. I will assume here without further discussion that, apart from the definition of local domain, the general property sharing schema (7) can do the work of principle A.

Principle B, which has been subject to much more critical discussion, is suspect in the sense that it is a negative condition. A standard rule says that something must have an antecedent, not that an antecedent must be absent (as implied by the notion "free"). In what follows, I will give an alternative for principle B (and by implication, also for principle C). The upshot of this discussion will be that, apart from a lexical classification of NPs and slight domain parametrization, there are no special binding conditions. Most properties seem to follow from more general conditions, which also apply to movement and numerous other constructions (see Koster 1987). A specific binding theory is just as undesirable and superfluous as a specific theory of movement.²

In (10), a selection is given of the numerous empirical problems facing the classical binding theory (1). Example (11) shows the well-known occurrence of bound pronominals in a local domain, which seems to be excluded by principle B:

(11) *John saw a snake near him.*

That there is no immediate universal solution to this problem is suggested by the fact that Dutch can have both anaphors and pronominals in this context:

(12) *Jan zag een slang naast zich/hem.*
John saw a snake near self/him

German shows a third variant, in which a morphologically marked reflexive is the *only* option in this context:

(13) *Johann sah eine Schlange neben sich/*ihm.*
John saw a snake near self/him

² An anonymous reviewer has raised the question why, given the variation in anaphoric systems and given my reduction of anaphoric dependency and movement to the same principle, one does not find the same variation among movement rules. This criticism is beside the point because the core rule of grammar (7) applies in conjunction with the lexical properties of the various dependent elements (see below). The variation is due to the lexicon, not to the core rule of property sharing.

Other languages, like Frisian, show an even more pervasive use of bound pronouns in local domains. We do not only find bound pronouns in the same context as in English (14b), but even in direct object position (14a):

- (14) a *Jelle wasket him.*
 Jelle washes him
 'Jelle washes.'
 b *Jelle seach in njiirre njonken him.*
 Jelle saw a viper near him

Frisian, like many other languages, does not seem to have morphologically marked reflexives distinct from pronominals, thereby forming a problem for the standard binding theory (1).

Middle English was similar in this respect, as shown by example (15) (from Faltz 1977):

- (15) *He cladde hym.*
 he dressed him
 'He dressed.'

Even in modern English there are residual bound pronouns in indirect object position. Thus, according to Faltz (1977), many speakers of English accept (16) (limited, by and large, to benefactives, for many speakers with a preference for the first and second person):

- (16) *John bought him a new car.*

Many similar and also other problems are met when we consider the anaphoric systems of a wider range of languages.

A last problem that I would like to mention here is the occurrence of long and short reflexives in many languages, often in complementary distribution. Dutch, for instance, can only have the short form *zich* (himself) in (17a), while (17b) only allows the long form *zichzelf*:

- (17) a *Jan vergist zich(*zelf).*
 John errs

- b *Jan haat zich*(zelf).*
John hates himself

3 A non-binding theory of anaphora

Since the traditional binding theory is problematic on both conceptual and empirical grounds, we would like to replace it by something else. The challenge, in my opinion, is not the formulation of an alternative binding theory (for instance, along the lines of Reinhart and Reuland (1993)), but to account for anaphoric phenomena on the basis of theoretical principles that also apply to other construction types. An alternative, in other words, should not only be an improvement over the existing binding theory in empirical terms, but preferably, also a theory that is in accordance with the uniformity principle and the general insight of generative research of the past twenty years that grammatical constructions can be accounted for by principles that are themselves not construction-specific.

It seems to me that such an alternative is available. The theory I have in mind starts from the assumption that Case plays a central role in the classification of anaphoric forms. This idea, first proposed by Martin Everaert, was further developed at the university of Groningen in work by Eric Reuland, Jelly de Jong (1996), Anko Wiegel (1996), and myself (1994).

The role of Case can be demonstrated with the following examples from Dutch (from Koster 1985):

- (18) a *Jan sprak urenlang over hemzelf (zichzelf).*
John talked for hours about himself
b *Jan zag een slang naast hem (zich).*
John saw a snake near him
c *Jan sprak namens hemzelf (zichzelf).*
John talked on behalf of himself
- (19) **Jan haat hemzelf (ok: zichzelf).*
Jan hates himself

Consider first example (19). Dutch has a specialized reflexive form *zich(zelf)*, which is obligatory under conditions of local binding in accusative contexts (as in (19)). In oblique contexts, however, *zich(zelf)* is not obligatory for many speakers and may be replaced by the pronominal form *hem(zelf)*, as is illustrated in (18).

Modern High German no longer allows this alternation and only has the specialized anaphoric form *sich*. In older German texts, this specialized form is often limited to accusative contexts. In dative contexts, one often finds the non-specialized form *ihm*, which can be used both as a bound anaphor and as a free pronoun:

- (20) a *Gott schuf den Menschen ihm zum Bilde.*
 God created the men him to the image
 'God created man in his image.'
- b *Andern hat er geholfen, und er kan ihm selber nicht helfen.*
 others had he helped and he can him self not help
 'He has helped others and cannot help himself.'
- (21) a *Er hat nicht mehr Mitleiden in ihm als ein Hund.*
 he had not more sympathy in him than a dog
 'There was no more sympathy in him than in a dog.'
- b *Wer hätte gedacht, dass der alte Mann so viel Blut in ihm gehabt hätte.*
 who had thought that the old man so much blood in him had had
 'Who had expected that the old man would have had such vigor.'

In other words, specialized anaphoric forms are in the cases discussed only defined for the accusative. In dative contexts, the same form may be used for local binding and for free pronominal reference. Not only Dutch has residues of that, also English, as is clear from examples like (16). Modern Frisian (14) and Middle English did not have any specialized anaphoric forms at all. In those languages, pronouns may also be used anaphorically.

This state of affairs is a clear indication that the Binding Theory (in conjunction with the standard classification of NPs), in part at least, only reflects accidental lexical properties of Modern English. It is not at all the case that pronouns must be universally free in local contexts. It all depends on the accidental lexical presence of a specialized anaphor: if a language has a specialized anaphor, like German *sich*, this form can normally not be replaced by a pronoun under conditions of local binding. If a language lacks specialized anaphors, like Frisian, pronouns are perfectly acceptable under conditions of local binding. As was shown by the German examples (see Wiegand (1996)), specialized anaphors were originally only found in accusative contexts.

Lexical specialization for local binding is not only determined by Case but also by person. Many languages, like Modern Dutch and French, limit the special anaphoric form only to the third person.

The theory of anaphoric binding that I would like to propose has the following properties:

- (22) I *There is no anaphora-specific or language-specific binding theory:*
- a Principle A follows from the general rule of local property sharing
 - b Principle B follows from a general markedness principle
- II *Differences among languages are lexical (NP classification)*
- a Morphological marking (German: *sich* vs. *ihn*)
 - b Structural Case (English: *himself*)

In this article, I will mainly focus on the markedness principle mentioned in Ib and the lexical classifications implied by II. The idea that Principle A of the traditional binding is an instance of a more general locality condition on grammatical dependencies has been discussed above and elsewhere (Koster 1987).

But also Principle B of the Binding Theory can be fruitfully replaced by a principle of more general scope. The principle I have in mind is the following:

(23) *Principle of Maximal Specialization*

In a grammatical dependency relation R, select the most specialized form.

The notion "most specialized form" can be defined as follows:

- (24) a form A is more specialized than B if A can fulfil fewer functions than B

This notion is related to the traditional structuralist notion of functional load: the more specialized a form, the less its functional load. In general, it seems to me, if a grammar can choose between two forms, the more specialized form is the preferred one. This principle explains the ungrammaticality of Principle B violations like:

- (25) **John washes him.*

According to principle (23), this sentence must be rejected (at least in the unmarked case) because *him* can be replaced by the more specialized form *himself*. The form *himself* is more specialized here because it can only be used as a locally bound reflexive in this context. The form *him* can also be used deictically here, i.e. without being bound by *John*.

It is by no means necessary for a language to have a specialized form for local binding. Thus, in Frisian such forms are lacking, hence the grammaticality of:

- (26) a. *Jelle wasket him.*
 Jelle washes him
 ‘Jelle washes.’

If classical Binding Principle B were a universal principle, this sentence would be ruled out. However, in Frisian, Middle English, and many other languages, such locally bound pronouns are entirely acceptable, contrary to what Principle B predicts. It seems to me that this is a simple and accidental lexical fact: the languages in question lack a more specialized form for a local binding.

In modern High German, specialized reflexive forms (like *sich*) must be used throughout a local binding domain. In earlier stages of German, however, the specialized forms were limited to structural accusative positions, i.e., forms like *sich* were lexically marked as accusative. In oblique positions, therefore, the pronominal *ihm* was the correct form, as was illustrated above.

In standard Dutch, as we saw, specialized forms like *zich* are only obligatory in structural accusative positions. In oblique positions, pronominals like *hem* are also possible. Since this locally bound *hem* is slightly substandard, we have an indication that two different lexical classifications are possible in Dutch. Standard Dutch, like modern High German, lexically defines the specialized reflexive form for all Case positions, while in an alternative and substandard classification, the specialized form is only defined for structural accusative positions, like in older stages of German.

Modern English also allows bound pronouns in oblique positions, as we saw above. One such usage is residual, as in the somewhat marginal (27):

- (27) *John bought him a new car.*

Indirect object positions in English are perhaps on their way to become structural object positions. In the oblique complement positions of Ps, however, specialized reflexive forms are not defined for English, hence the grammaticality of (28), with its bound pronominal *him*:

- (28) *John saw a snake near him.*

Traditionally, such sentences have been considered a problem for the standard Binding Theory.³ There are, however, few reasons to assume that we need a special Binding Theory. In a great number of languages, anaphoric binding seems to be completely accounted for by principles that are not construction specific and an appropriate lexical classification.

4 Conclusion: the uniformity of grammar

A standard approach to the empirical and conceptual inadequacies of the Binding Theory has been the search for a modified or even an alternative Binding Theory (like, for instance, Reinhart and Reuland 1993). It seems to me, however, that this approach is ill-conceived. A special Binding Theory is a construction-specific device. Historically speaking, generative grammar has been most successful in eliminating such construction-specific rules and principles. In tune with this general trend, it can be assumed that we do not need a Binding Theory, neither a (modified) standard one, nor an alternative one.

Binding Principle A can be seen as a variant of standard property sharing in local contexts. Conceived this way, local binding is no longer a construction-specific rule. Similarly, Principle B (and also Principle C) can be successfully replaced by the non-construction-specific Principle of Maximal Specialization (23). This principle is not only more general, but also more empirically adequate, as we have seen.

Most important from the present perspective is that the Principle of Maximal Specialization is not anaphora specific but also applicable in other domains of grammar, particularly in movement constructions. Thus, the trace in (29a) cannot be replaced by a reflexive (29b) or a pronoun (29c):

- (29) a *Who* did you see *t* ?
 b **Who* did you see *himself* ? [+ Case checking]
 c **Who* did you see *him*? [+ Case checking, + free]

³ An anonymous reviewer has pointed out that the proposal presented here would incorrectly rule in **John talked about him* (*John* and *him* coreferential). Note, however, that there are good reasons to classify prepositional objects as structural accusatives rather than as oblique Cases. Clear evidence for this view can be found in the fact that English prepositional objects undergo passive (pseudo-passivization). For structural accusatives, English has specialized anaphors like *himself*.

One might say that this fact is explained by the application of movement rules: movement leaves a trace and not a reflexive or a pronoun. However, there are reasons to assume that this is not the right explanation. The ungrammaticality of (29b) and (29c) is also explained by the Principle of Maximal Specialization (23). According to (23), an empty category (a trace) must be selected in (29) because it is the most specialized form to serve the purpose of chain formation. Selection of a reflexive or a pronoun in a Wh-chain would involve less specialized forms, because lexical reflexives and pronouns also fulfil another role, namely satisfaction of the Case requirements of the position in question. Both lexical elements can also fulfil other roles, such as the free use of the pronoun *him*. This extra functional load is indicated between the square brackets following the examples (29b) and (29c).

If both the movement hypothesis and the Principle of Maximal Specialization are empirically adequate in contexts like (29), the interesting question arises whether there are contexts which favor one of these hypotheses over the other. It seems to me that such crucial evidence exists, namely in cases where resumptive pronouns are possible or even required. Recall that the Principle of Maximal Specialization only describes the unmarked Case. In more complex cases, it may be overruled by other requirements. Take for instance the following example (from Reinhart (1983)):

- (30) I know what Mary and *Bill* have in common.
 Mary adores *him* and *Bill* adores *him* too.

As Reinhart points out, there are contexts (like this one) in which a locally bound pronoun is appropriate, contrary to what one might expect under Principle B. The Principle of Maximum Specialization, in contrast, only indicates which lexical choice represents the default case. This type of situation is much more common in grammar than usually assumed. Thus, if Wh-chains involve island violations, a resumptive pronoun is often possible:

- (31) a ?*Which* book did you wonder who said he had read *it*?
 b ?*Welk boek* zei hij dat hij niet meer wist wanneer hij *het* gelezen had?
 which book said he that he not anymore knew when he it read had

Both the English example (31a) and the Dutch example (31b) involve a Wh-island violation and both examples allow a resumptive pronoun instead of a trace. There are Swedish cases (from Elisabet Engdahl, cited by Cinque 1990:62) which also involve island violations and in which a resumptive pronoun is even required:

- (32) *Vilket ord visste ingen hur det/*t stavas?*
 which word knew no one how it is spelled

Assuming that there is no anti-cyclical post-movement lexical insertion, such examples are a serious problem for the hypothesis that Wh-chains are formed by movement. Under the alternative assumption that chains are formed by base rules ("merge" only) and that a principle like (23) determines the unmarked case, lexical items instead of traces are possible in principle. Under this alternative, empty NPs, being the most specialized forms possible, only are the least marked forms possible in the positions in question. In complex sentences with their specific processing problems, lexical forms seem to be possible to facilitate processing.

There are several other instances of the Principle of Maximal Specialization, such as the Avoid Pronoun Principle of Chomsky (1981). In the following example, the pronoun *his* is preferably interpreted as not being bound by *John*. Again, a more specialized form seems available for this context, namely PRO. The pronoun *his* has a heavier functional load because, unlike PRO, it can also be free (as a deictic pronoun) in this context.

- (33) *John would much prefer [his going to the movie].* [+ free]

The Principle of Maximal Specialization also solves a problem in Frisian, discussed by J. Hoekstra (1994). In Frisian accusative contexts, both the pronoun *harren* and the pronoun *se* can be used, as in (34).

- (34) *Hy narre harren/se.* (J. Hoekstra 1994)
 he teased them

The pronoun *se* can also be used in the nominative and is therefore less specialized. The Principle of Maximal Specialization (23) predicts that in dependencies, such as local binding, only the pronoun *harren* can be used. This prediction happens to be correct:

- (35) a *Hja waskje harren.*
 they wash themselves
 b **Hja waskje se.* [+nominative]

A very similar observation can be made in Dutch. In Dutch oblique contexts, 3rd person singular feminine, both the forms *ze* and *d'r* (reduced form of *haar* 'her') can be used:

- (36) Ik woon bij *ze/d'r*.
I live with her

Like in Frisian, the pronoun *ze* (*she*) can also be used in the nominative, thereby entailing a heavier functional load (less specialization). Once more, the Principle of Maximal Specialization makes the correct prediction. Only the pronoun *d'r* can be used in local dependencies:

- (37) a *Ze/*D'r* woont bij me.
She lives with me
b *Marie* had haar tas niet bij *d'r/*ze*. [ze = +nominative]
Mary had her bag not with her
'Mary didn't have her bag with her.'

More predictions are made, but I will leave it at this. The Principle of Maximal Specialization seems superior to Binding Principle B in a number of respects. It accounts for the standard principle B facts, but, in conjunction with morphological definition of anaphors in terms of case, also for several exceptions to Principle B (occurrence of locally bound pronouns in oblique contexts in English). As an indication of the unmarked case, it also explains the occurrence of bound pronouns in marked cases (such as (30)). Unlike Principle B, it also allows the systematic use of locally bound pronouns in the many languages like Frisian, which lack the relevant lexical specializations.

Most important of all from a theoretical perspective is that the Principle of Maximal Specialization is not anaphora specific but also applicable in many other constructions, including movement constructions. All in all, the Principle of Maximal Specialization is not only an empirical improvement over Principle B, but also a contribution to the uniformity of grammar, the leading idea that all local dependencies, movements and non-movements alike, are governed by similar grammatical principles. This outcome confirms the theoretical tenets of Chomsky (1981) and casts serious doubt on later attempts to dissociate movements from other constructions, which would be a step away from the uniformity of grammar.

References

- Chomsky, Noam. 1973. Conditions on Transformations. In Steven R. Anderson & Paul Kiparsky (eds) *A Festschrift for Morris Halle*. New York: Holt, Rinehart and Winston. 232-286.
- Chomsky, Noam. 1977. On Wh-movement. In Peter Culicover, Tom Wasow & Adrian Akmajian (eds) *Formal Syntax*. New York: Academic Press.
- Chomsky, Noam. 1981. *Lectures on Government and Binding*. Dordrecht: Foris.
- Chomsky, Noam. 1986. *Knowledge of Language*. New York: Praeger.
- Chomsky, Noam. 1995. *The Minimalist Program*. Cambridge, Mass.: MIT Press.
- Cinque, Guglielmo. 1990. *Types of A'-dependencies*. Cambridge, Mass.: MIT-Press.
- Emonds, Joe. 1970. Root and Structure-Preserving Transformations. Doctoral Dissertation. MIT, Cambridge, Mass.
- Faltz, Leonard. 1977. Reflexivization: A Study in Universal Syntax. Doctoral Dissertation. University of California, Berkeley.
- Hoekstra, Jarich. 1994. Pronouns and Case; On the distribution of Frisian *harren* and *se* (them). *Leuvense bijdragen* 83. 47-65.
- Jong, Jelly de. 1996. *The Case of Bound Pronouns in Peripheral Romance*. Doctoral Dissertation. Groningen Dissertations in Linguistics 16.
- Koster, Jan. 1978. *Locality Principles in Syntax*. Dordrecht: Foris.
- Koster, Jan. 1985. Reflexives in Dutch. In Jacqueline Guéron, Hans-G. Obenauer & Jean-Yves Pollock (eds) *Grammatical Representation*. Dordrecht: Foris. 141-167.
- Koster, Jan. 1987. *Domains and Dynasties*. Dordrecht: Foris.
- Koster, Jan. 1994. Towards a new theory of anaphoric binding. In B. Lust, G. Hermon & J. Kornfilt (eds) *Syntactic theory and first language acquisition: crosslinguistic perspectives. Vol II Binding, dependencies and learnability*. Hillsdale NJ: Erlbaum. 41-69.
- Reinhart, Tanya. 1983. *Anaphora and Semantic Interpretation*. London & Sydney: Croom Helm.
- Reinhart, Tanya & Eric Reuland. 1993. Reflexivity. *Linguistic Inquiry* 24. 657-720.
- Wiegel, Anko. 1996. Pronominal systems and Case. Manuscript. Groningen University.

Levels of Representation and the Elements of Anaphora

Howard Lasnik

One of the most fascinating, and most enduring, topics in the generative investigation of anaphora is the question of levels of representation relevant to the determination of anaphoric connection.* In terms of the influential theory of anaphora of Chomsky (1981), with its three binding conditions, the question concerns the level or levels of representation that must satisfy those conditions. Over the years, a variety of technological proposals have been put forward, none of them conceptually very satisfactory. Recent 'minimalist' characterizations of the general form of syntactic theory render most of those proposals not just unsatisfactory but unstatable, since the proposals crucially rely on a level of representation, S-structure, which is claimed not to exist. I will consider the quite strong evidence motivating those early proposals and ultimately suggest a way of capturing the apparent S-structure effects without direct appeal to S-structure, thus responding to a potentially powerful counter-argument to a major tenet of minimalism.

The fact that anaphora has obvious semantic aspects has always suggested that its syntax, the binding conditions, should be determined at LF, the syntax-semantics interface level. However, early on, difficulties with such a theory were recognized. Discussing the following examples, Chomsky (1981:196-197) argues that Condition C must apply at S-structure:

- (1) Which book that John_i read did he_j like?
- (2) *He_j liked every book that John_i read.
- (3) *I don't remember who thinks that he_j read which book that John_i likes.

* This research was supported in part by NSF grant SBR-951088. I would like to acknowledge the very helpful suggestions of Željko Bošković and those of a reviewer.

Chomsky's point is that following QR, the LF of (2) would be structurally parallel to the S-structure (and LF) of (1), where *John* is outside the c-command domain of *he*. Thus, as in (1), there should be no Condition C effect if LF is the level relevant to that condition. Similarly for (3) following LF *wh*-movement. Contrary to the prediction of the LF theory, in both instances the hypothesized LF movement, unlike the overt movement creating (1), has no effect on binding possibilities. This strongly suggests Chomsky's conclusion: that Condition C is specifically a requirement on S-structure.

The preceding argument is based on what might be termed unexpected ungrammaticality. Chomsky also offers an argument, to the same conclusion, based on unexpected grammaticality. Chomsky proposes that (4) is the target of an LF rule of focus movement.

- (4) John said that Bill had seen HIM.

When *HIM* raises, it leaves behind a variable, which, according to Chomsky's account of strong crossover, must be A-free as dictated by Condition C. Since in the postulated LF, the variable would be bound by *John* on the relevant (and possible) reading, we have an additional argument that Condition C is sensitive to properties of S-structure rather than of LF.

Barss (1986) draws the same conclusion for Condition A, based on examples like the following:

- (5) John_i wonders which picture of himself_i Mary showed to Susan.
 (6) *John_i wonders who showed which picture of himself_i to Susan.

(5) shows that an anaphor within the embedded CP Spec can be licensed by an antecedent in the matrix subject position. Given this fact, the ungrammaticality of (6) is surprising if anaphors can be licensed by virtue of their LF positions. On the then standard theory, in LF, the WH-phrase in situ, *which picture of himself*, moves to the embedded CP Spec position, where it takes scope. Thus, at LF, the configurational relation between *himself* and its antecedent is virtually identical in (5) and (6). Hence, the ungrammaticality of (6) shows that anaphors must be licensed at a level prior to LF, e.g., S-structure (and possibly at LF as well). (6) is ruled out because the reflexive fails to be licensed at that level.

Chomsky (1981) explores another phenomenon with potential implications for the issues under discussion here. Assuming that expletive *there* is coindexed with its

associate, Chomsky observes that a perfectly grammatical example like (7) incorrectly constitutes an apparent violation of Condition C.

- (7) There is a man in the room.

The proposal of Chomsky (1981) is that the coindexing between expletive and associate is of a different sort than that involved in Binding Theory (in particular, co-superscripting as opposed to co-subscripting). Chomsky (1986a) reconsiders the phenomenon, and presents a more attractive account: that in the LF component, the associate A-moves to the position of the expletive, as illustrated in (8).

- (8) A man is *t* in the room.

Since *t* is here the trace of A-movement, it does not fall under Condition C, so the example is correctly let in. It is significant that this account crucially depends on the rejection of the Chomsky (1981) argument. If S-structure must satisfy Condition C, then later movement will be of no benefit. As I will discuss at length below, independent of the status of the Chomsky (1986a) argument, the same problem arises within the Minimalist Program of Chomsky (1995), since that program denies S-structure any significant status.

Uriagereka (1988), as part of an extensive discussion of binding theory and levels of representation, pursues the Chomsky (1986a) expletive replacement proposal further. Based on the acceptability of (9), Uriagereka proposes that anaphors need not be licensed at S-structure, reasoning that the required c-command relation between *two knights* and *each other* holds at LF (10) but not at S-structure (9).¹

- (9) There arrived two knights on each other's horses.
 (10) Two knights arrived *t* on each other's horses.

¹ Actually, according to the specific analysis of expletive-argument pairs in Chomsky (1986a), (9) would straight-forwardly satisfy the binding requirement of the anaphor at S-structure, since Chomsky claimed that throughout the derivation expletives are coindexed with their associated arguments. But see Lasnik (1992a) for arguments against this position.

This interesting argument is actually independent of expletive replacement *per se*, since, as discussed in some detail by Lasnik and Saito (1991), even direct objects of transitive verbs generally seem to c-command certain adjuncts:²

- (11) I saw two men on each other's birthdays.

In certain versions of Case theory, for example one proposed by Chomsky (1991), and examined further by Lasnik and Saito (1991) and Lasnik (1993), in the LF component a direct object raises to Spec of Agr_O, where its Case is licensed. On standard assumptions about phrase structure, (11) might then be a further example of successful licensing of an anaphor at LF (via A-movement) remedying failure in overt syntax. Below, I will have much more to say about examples like (9) and (11). For the moment, I simply point out the contradiction between this phenomenon and the Chomsky (1981)/Barss (1986) argument that binding conditions must be satisfied at S-structure.

As noted in Lasnik (1993), one way to resolve the contradiction is to reject the existence of the LF operations that Chomsky (1981) was assuming. A somewhat less far reaching alternative, also mentioned in Lasnik (1993), is to limit the operation of such rules as QR and LF *wh*-movement so that only the quantificational head moves, and not the entire expression, as proposed by Hornstein and Weinberg (1990).³ Thus, the generalization put forward by Chomsky (1981) might be captured as a property specifically of A'-movement, without Chomsky's conclusion that the binding conditions hold of S-structure:

Such examples indicate that syntactic [overt] movement and movement in the LF-component have quite different effects with respect to the binding theory. This theory applies properly after syntactic movement, but each rule of the LF component converts S-structures to which the binding theory applies correctly to LF-representation to which it applies incorrectly. (Chomsky 1981:197)

² I don't give a minimal pair here, such as "I saw two knights on each other's horses" because of the possibility of taking the material after the verb as an NP, "two knights on each other's horses". No such possibility exists for the example in the text.

³ It is not immediately obvious how to extend this to the focus movement case. Also, while it is easy to imagine how scope facts can be handled on the Hornstein and Weinberg theory (or, for that matter, on a theory with no LF A'-movement at all), one of the major arguments for QR, May's (1985) account of antecedent contained deletion, demands that the entire expression move. See Lasnik (1993), Hornstein (1994), and Lasnik (1995a) for discussion.

The next question involves LF A-movement, as postulated for (9) and (11). As noted above, Uriagereka suggests expletive replacement as an account for the licit binding of the reciprocal in (9). However, Lasnik and Saito (1991) and den Dikken (1995) show that expletive replacement does *not* in general create new binding possibilities. For example, it is well known that a raised subject can antecede an anaphor in the higher clause (the classic argument that D-structure need not obey Condition A), but the associate of a raised expletive cannot:

- (12) Some linguists seem to each other [*t* to have been given good job offers].
 (13) *There seem to each other [*t* to have been some linguists given good job offers].

Other phenomena known to involve A-binding pattern similarly. (14) illustrates this for weak crossover.

- (14) a Some defendant_i seems to his_j lawyer to have been at the scene.
 b *There seems to his_j lawyer to have been some defendant_i at the scene.

This set of facts indicates that if LF is the level of representation relevant to the licensing of anaphors and bound pronouns, then literal expletive replacement cannot be correct. Interestingly, Chomsky (1991) already arrived at the same conclusion based on scope properties of existential constructions. Substitution would result in identical LFs for (15) and (16).

- (15) A man is likely to be here.
 (16) There is likely to be a man here.

But the interpretive possibilities diverge. In (15), *a man* can evidently have wide or narrow scope with respect to *likely*, while (16) allows only narrow scope for *a man*. The same sort of interpretive divergence arises with respect to scope of negation:

- (17) Many linguistics students aren't here.
 (18) There aren't many linguistics students here.

Partly for these reasons, Chomsky (1991) modified his (1986) substitution analysis, proposing instead that the associate adjoins to *there*, the latter being a sort of LF clitic.

The generalization that emerges from all of this is that the associate of *there* always displays 'low' behavior, while an overtly moved NP displays 'high' behavior. It is perhaps tempting to conclude that there actually is no movement relation between the position of *there* and that of the associate. However, the standard argument for movement is a compelling one: that it provides the basis for an account of the familiar superficially bizarre agreement paradigms displayed by these constructions, with the verb agreeing with something that is not its formal subject:⁴

- (19) a There is/*are a man here.
b There are/*is men here.

Hence, I will pursue the problem of low behavior for the associate in another way. In particular, I will explore the nature of the movement, exactly what moves, and how this interacts with the elements of the theory of anaphora.

Lasnik and Saito (1991) show that existential constructions in ECM configurations display asymmetries parallel to those seen in subject raising constructions:⁵

- (20) The DA proved [two men to have been at the scene] during each other's trials.
(21) *The DA proved [there to have been two men at the scene] during each other's trials.

Recall that in connection with Uriagereka's example above I noted that direct objects of verbs, whether the verbs are unaccusative (9) or transitive (11), are able to bind into adjuncts. I also noted that under standard assumptions about phrase structure, those direct objects must be assumed to undergo A-movement to some higher position for that binding to take place. However, in a theory of phrase structure of the sort proposed by Larson (1988), there might have been an alternative, since in such a theory, adjuncts are actually base generated lower than complements.⁶ It is in this

⁴ This argument depends on the 'minimalist' assumption that the configurations relevant to syntactic relations are severely limited, essentially to Spec-head and head-head (via head adjunction). Thus, agreement at a distance would not be possible, a limitation in descriptive power, all else equal.

⁵ In examples (20)-(25), the adjunct is to be taken as modifying the matrix predicate, as indicated by the brackets. With the adjunct modifying the embedded predicate, even the *there* examples are acceptable, as expected in parallel to Uriagereka's example.

⁶ See also Kayne (1994, ch.7).

connection that the examples examined by Lasnik and Saito become particularly significant, since for those examples no Larsonian alternative is even possible. There is no way that an adjunct modifying the higher clause can be base generated lower than an argument of the lower clause (e.g., the ECM subject in (20)). We are led to the conclusion of Lasnik and Saito, and of Postal (1974) before them (and based on similar arguments): that the ECM subject undergoes raising.⁷ The associate of *there* must then undergo raising of a quite different sort.

It is important to note that the asymmetry seen in (20)-(21) is not limited to reciprocal licensing. All standard c-command phenomena display the same pattern. (22)-(23) illustrate the corresponding weak crossover asymmetry:

- (22) The DA proved [no suspect, to be at the scene of the crime] during his trial.
- (23) *The DA proved [there to be no suspect, at the scene of the crime] during his trial.

And negative polarity item licensing is shown in (24)-(25).

- (24) The DA proved [noone to be at the scene] during any of the trials.
- (25) *The DA proved [there to be noone at the scene] during any of the trials.

I turn now to possible accounts of the several parallel asymmetries seen above. The first possibility is based entirely on Chomsky (1991). Suppose, as hinted above, that accusative Case is licensed in the Spec of Agr₀ above the licensing verb, via LF A-movement.⁸ If we assume, in the spirit of the Minimalist program, that all of the c-command phenomena considered above involve LF, this immediately gives the correct results for direct objects, for ECM subjects, and, of course, for overtly raised subjects (where there is no relevant difference between the S-structure and the LF). Further, the version of expletive replacement espoused in Chomsky (1991) –

⁷ And, again, short of the Larsonian structure, we are led to the conclusion that direct objects also raise. Postal did not arrive at this latter conclusion, primarily because he took the structural requirement on binding phenomena to involve command (weaker than c-command in specifying clausal nodes only).

⁸ Similarly for the Case of the associate of *there*, given Uriagereka's example above. This is expected on the Belletti (1988) theory, developed further by Lasnik (1992b, 1995c), in which *be* and unaccusatives are Case licensors. The movement to (a position near) *there* is then not for Case reasons, but for agreement reasons, as in Martin (1992), and Groat (1995).

adjunction to *there*, rather than substitution for it – potentially makes the necessary distinction between NPs with high behavior on the one hand and associates of *there* on the other. The latter will *adjoin* to *there*, hence arguably will not be in the appropriate position to c-command the anaphors, NPIs, etc. in the examples above. This is a natural extension of the Chomsky (1991) account of scope facts in existential constructions. There are, however, problems with that account. First, as Chomsky points out, in his example cited as (18) above, repeated as (26), it is not the case that there is no scope relation between negation and *many linguistics students*.

(26) There aren't many linguistics students here.

Rather, *many linguistics students* necessarily has narrow scope. While it is true that if that NP were to replace *there*, it would be expected to have (at least as one possibility) wide scope, under the adjunction analysis, according to Chomsky no scope relation is established between negation and *many linguistics students*. Chomsky indicates that under this circumstance, the scope of *many linguistics students* can be assumed to be narrow. Chomsky analogizes this situation to that in (27).

(27) Pictures of many students aren't here.

However, in (27), there truly is no scope relation between negation and *many students*. The sentence is clearly not synonymous with (28).

(28) Pictures of few students are here.

But such synonymy would be expected on the implied account of (26), since that example is synonymous with (29).

(29) There are few linguistics students here.

In addition to this empirical problem, there is a technical problem. Chomsky evidently bases his argument that no scope relation is established between negation and *many linguistics students* in the LF of (26) on the assumption that there is no c-command relation between those two expressions. However, on the theory of adjunction proposed by May (1985), developed in Chomsky (1986b), and assumed in all of Chomsky's writings since, there would be a relevant c-command relation in

(26). *Many linguistics students* would c-command negation, just as much as it would in (30).

(30) Many linguistics students aren't here.

This is so because on May's and Chomsky's theory of adjunction, when α adjoins to β , β becomes a segmented category, and α c-commands anything β did prior to the adjunction. Thus, the scope problem that largely motivated the change from expletive substitution to expletive adjunction is actually not resolved by that change. This indicates that the solution to the asymmetries lies elsewhere.

Chomsky (1995) suggests a revised theory of the LF movement involved in expletive constructions, as part of a revised theory of LF movement more generally. Beginning with the standard Minimalist assumption that all movement is driven by the need for formal features to be checked, Chomsky argues that, all else equal, movement should then never be of an entire syntactic category, but only of its formal features.⁹ PF requirements will normally force movement of a category containing the formal features, via a sort of pied-piping, under the reasonable assumption that a bare feature (or set of features) is an ill-formed PF object. For LF movement, on the other hand, pied-piping will normally not be necessary, hence, by economy, will not even be possible. Only the formal features will move, and they will move exactly to the heads that have matching features. In a standard existential sentence, then, the associate does not move to *there*. Rather, only the formal features move, and only to a corresponding functional head (or heads). As observed by Chomsky, the feature movement analysis of existential constructions has the potential to solve the scope problem. If in LF, only the formal features of *many linguistics students*, rather than the entire expression, move to a functional head or heads above negation (presumably the Agr_s head), it is reasonable to conclude that the quantificational properties remain below negation. Then, if it is this structure that determines scope, the desired results are obtained.

The feature movement analysis, being in a sense a more extreme version of the Hornstein and Weinberg proposal mentioned above, would seem to properly handle the anaphora and NPI paradigms in *there* constructions as well. Recall the reciprocal facts of (12)-(13), repeated as (31)-(32).

⁹ See Martin (1992) and Groat (1995) for related proposals.

- (31) Some linguists seem to each other [*t* to have been given good job offers].
 (32) *There seem to each other [*t* to have been some linguists given good job offers].

When the entire NP has raised, as in (31), whatever properties of the NP are relevant to licensing an anaphor are in the appropriate structural position to do so (both at S-structure and at LF). When, by hypothesis, only the formal features have raised, as in (32), it is reasonable to conjecture that the referential properties relevant to licensing an anaphor remain below.¹⁰ Parallel accounts could be provided for NPI licensing and WCO, as in (33)a,b vs. (34)a,b.

- (33) a No good linguistic theories seem to any philosophers [*t* to have been formulated].
 b Some defendant_i seems to his_i lawyer to have been at the scene.
 (34) a *There seem to any philosophers [*t* to have been no good linguistic theories formulated].
 b *There seems to his_i lawyer to have been some defendant_i at the scene.

On this kind of account, then, the elements of the theory of anaphora are not merely formal features. Interestingly, Chomsky (1995) proposes just the opposite: that the elements of anaphora are precisely formal features. As far as I can tell, there are two bases for Chomsky's position. One to which I will return involves control. The other concerns (some of) the Lasnik and Saito ECM facts mentioned above. Recall that the ECM subject licenses elements in the higher clause. Further, direct object licenses elements that are arguably base generated higher than direct object. In both situations, the formal features of the licensing NP are assumed to undergo LF raising to Agr_O. Chomsky thus reasons that "the features adjoined to Agr_O...have A-position properties, c-commanding and binding in the standard way." [p.272] Thus, for all purposes (except scope), feature movement is claimed to have the same consequences as NP movement. However, we have seen overwhelming evidence that this is not so. The (low) associate of *there* cannot bind a (high) reciprocal or license a (high) NPI or a (high) bound pronoun, even though the formal features of the associate raise to the appropriate higher position. For the first of these problems, Chomsky offers a solution. Assuming the LF anaphor movement analysis of Condition A effects,

¹⁰ I do not mean to deny the relevance of formal agreement features to the licensing of anaphors, but merely to claim that more is involved.

Chomsky indicates that the LF structure of the relevant portion of an example like (32) would be (35)a or b, where AN is the anaphor, FF is the set of raised formal features, and α is the X^0 -complex formed from INFL and the matrix V.

- (35) a [INFL AN [FF (*linguists*) α]]
 b [INFL FF (*linguists*) [AN α]]

Chomsky concludes that "On reasonable assumptions, neither of these structures qualifies as a legitimate binding-theoretic configuration, with AN taking FF (*linguists*) as its antecedent" (Chomsky 1995:275-76). Chomsky does not mention failure of NPI licensing and parallel failure of bound pronoun licensing (WCO effects). It is not clear that Chomsky's account of anaphora failure would extend to these phenomena, particularly in light of the fact that, other than c-command, the relevant structural relations are quite different. Further, there is a more fundamental problem with the account. While it might correctly distinguish among the subject raising to subject position examples, disallowing anaphor binding when it is *there* that overtly raises, it incorrectly excludes *all* anaphor binding with 'subject raising to object position'. For example, as noted above, Chomsky, following Lasnik and Saito, takes a sentence just like (20)a to be acceptable, but (36), the relevant portion of its LF, will be indistinguishable from (35). β is the X^0 -complex formed from Agr_O and the matrix V.

- (36) a [Agr_O AN [FF (*two men*) [β]]]
 b [Agr_O FF (*two men*) [AN β]]

There is, thus, compelling reason for rejecting the idea that the (sole) elements of anaphora are formal features. Before turning to Chomsky's argument, based on control, for the position that I am rejecting, I would like to sketch a theory (perhaps the only natural theory) that can handle all of the facts considered so far. Note first that overt raising to subject position is unproblematic on any of the accounts. The raised NP displays high behavior in all respects, exactly as expected, on the null assumption that all properties of the NP are raised with it. Next, the associate of *there*, in simple existential constructions, in subject raising constructions, and in ECM constructions always displays low behavior, except for the agreement properties of the higher Agr. This is straightforward under the hypotheses that (i) the formal features, and only the formal features, of the associate raise; and (ii) that anaphors, NPIs, and bound pronouns are licensed by properties (plausibly semantic ones) other

than (or in addition to) formal features. The one remaining problem is the disparity between direct objects and ECM subjects, which can license apparently higher items, and *there* in an ECM configuration, which cannot. The latter is unproblematic. The associate of *there* remains low, even if its formal features move high, possibly as a consequence of featural deficiency of *there* itself. The former, on the other hand, is deeply problematic. Under standard Minimalist assumptions, there is movement involved in these constructions, movement for Case checking to Agr_O, but *covert* movement, so only the formal features move. And, as we have seen in detail, features do not suffice to license the items under investigation here. Thus, there is a paradox on those standard assumptions. The crucial standard assumption can be questioned. Koizumi (1993, 1995), revising and extending ideas of Johnson (1991), argues that accusative Case is checked overtly in English, just like nominative Case.¹¹ The accusative NP overtly raises to Spec of Agr_O (with V raising to a still higher head position).¹² If this is correct, the seemingly paradoxical asymmetry is immediately reduced to the independent pied-piping asymmetry. In the *there* construction, the only movement is the covert movement of the formal features of the associate to the Agr head. For an ECM subject or the object of a transitive or unaccusative verb the movement is overt, hence, of the entire NP, with all its semantic/referential properties necessary for licensing anaphors, NPIs, and bound pronouns. Interestingly, this resolves a paradox discussed by Lasnik and Saito (1991), as well. Lasnik and Saito were concerned to explain how an ECM subject, or a direct object, is high enough to c-command all the licensees outlined above. They suggested LF raising to Agr_O as a possibility. However, they also noted the existence of overwhelming evidence that many of these licensing effects crucially involve S-structure configuration. The present approach, based on Koizumi's analysis, immediately resolves this tension (a tension made extreme under the Minimalist claim that there is no significant level of S-structure). The licensing is at LF, but is as if at S-structure, since the only relevant

¹¹ See Lasnik (1995a,b) for further arguments. And see Vanden Wyngaerd (1989) for what was, as far as I know, the earliest proposal that overt raising to Spec of Agr_O creates binding possibilities.

¹² A reviewer notes a potential problem for a Koizumi type analysis of English: the Germanic VO languages (English, Scandinavian) contrast with the Germanic OV languages (Dutch, German) with respect to verb-object adjacency, the lack of adjacency in the latter occasionally explained by overt raising to Spec of Agr_O. Zwart (1993), revised as Zwart (1997), is a major example of such an analysis. Interestingly, though, Zwart bases his major arguments for raising to Agr_O in Dutch on Vanden Wyngaerd (1989). But Vanden Wyngaerd explicitly, and persuasively, argues that English does not differ from Dutch in this regard. The account of the adjacency asymmetry must then lie elsewhere.

movement is overt. Covert movement, involving merely formal features, is incapable of creating new licensing configurations for anaphora, etc.

I now must return to Chomsky's contrary argument that the elements of anaphora are indeed formal features. As noted above, there are actually two aspects to the argument. The first, based on the grammatical examples of Lasnik and Saito, is entirely theory internal, relying on the assumption that raising to Agr_0 is covert in English. Since that approach to the ECM phenomena led to a flat contradiction, I rejected it in favor of Koizumi's *overt* raising account, an account that has considerable independent motivation. Chomsky's empirical argument involves control. He presents an example suggesting that the associate of *there* behaves as if it is high, in its ability to control PRO in an adjunct:

(37) There arrived three men (last night) without [PRO] identifying themselves.

As (38) shows, a typical object cannot control PRO in this construction:

(38) *I met three men (last night) without identifying themselves.

Thus, Chomsky reasons that feature raising, in this instance to Agr_s , does create new control configurations, and, a fortiori, new binding configurations. Momentarily, I will question the generality of the control phenomenon, but even if Chomsky turns out to be correct about control, it will not be necessary to draw a broader conclusion about binding. There are significant and well known differences between control and binding. For example, as discussed by Lasnik (1992a), even languages unlike English in having 'subject oriented' anaphors still have structures of 'object control'.^{13,14} (39)-(40) illustrate this for Polish.

¹³ Subject orientation remains a mysterious phenomenon. An intriguing possibility is that it relates to how Case is licensed (as suggested by Lasnik (1993)), or to *when* Case is licensed, with covert movement of (formal features of) objects to their Case position resulting in inability of those objects to license anaphors. At this point, however, this is just wild speculation.

¹⁴ Norvin Richards points out that there is another way to look at this property of control on which it is less obviously relevant to the point at issue: 'Subject orientation' seems to be a property of particular anaphors, rather than of languages per se. Given that perspective, PRO could be regarded as a lexical item without that specific property.

- (39) Jan_i opowiadał Marii_j o swoim_{i,*j} zachowaniu.
 John telling Mary about self's behavior
 'John was telling Mary about his/*her behavior.'
- (40) Jan_i kazał Marii_j [PRO_{j,*i} napisać artykuł].
 John told Mary write article
 'John told Mary to write an article.'

Further, control has thematic aspects that are lacking in other instances of anaphora, yet another reason for drawing a distinction.¹⁵

Before concluding this discussion, I would like to further explore the intriguing control phenomenon that Chomsky notes. Chomsky implies that the associate of *there* in (37) is behaving just as an overtly raised subject, as in (41), would.

- (41) Three men arrived (last night) without PRO identifying themselves.

But already there is some difference. While (41) is perfect, (37) is somewhat degraded for many speakers.¹⁶ This contrast is heightened if the adverbial is fronted:

- (42) Without PRO identifying themselves, three men arrived.
 (43) ?*Without identifying themselves, there arrived three men.

Further, under raising, the contrast between structures like (37) and (41) greatly intensifies. In the following examples, the adverbial is intended as being in the higher clause, along with the raised subject or *there*:

- (44) Someone seems to be available without PRO seeming to be eager to get the job.
 (45) *There seems to be someone available without PRO seeming to be eager to get the job.

¹⁵ See Lasnik (1992a) for discussion.

¹⁶ Further, as Bob Fiengo pointed out in the discussion following the oral presentation of this paper, with a slight change in the adverbial, (37) itself degrades substantially:

(i) ?*There arrived three men without saying hello

There is no reason this should be so if raised features of the associate of *there* can control. Finally, while (38) is clearly bad, it is not only complements of unaccusatives that are reasonably acceptable as controllers. The following example is considerably better than (38), even if not quite as good as (37):

(46) The news upset John while reading the paper.

Perhaps thematic properties are involved in control into an adjunct (as they are often assumed to be into a complement): the object is a possible controller because the subject is too low on the thematic hierarchy. In (37), the subject is not thematic at all. In (46), it is low relative to the subject.

Until this array of facts is sorted out, an interesting typological claim made by Chomsky must be held in abeyance. Chomsky indicates that languages with expletives of the *there* type (i.e., with no agreement features of their own) allow control in the constructions at issue, while languages with expletives of the *il* type (with agreement features of their own) do not.¹⁷ This is because there will be raising of the features of the associate in the former instance but not the latter. Thus, he claims that Italian (with its *there* type expletive) and French contrast:

(47) Sono entrati tre uomini senza identificarsi.

(48) (*)Il est entré trois hommes sans s'annoncer.

But again, there is some question about the data. Every French speaker I have collected data from finds control in (48) fairly acceptable or completely so.¹⁸ Thus, it is not so clear that French and English contrast. Resolution of these important issues awaits further exploration of control in general and in the Minimalist framework in particular.

The tentative conclusion of this investigation is that for phenomena known to involve c-command, LF movement creates no new licensing possibilities.¹⁹ This result

¹⁷ Chomsky indicates that the null subject parameter is also somehow relevant, but according to his analysis, that factor is orthogonal. A priori, a null subject could be of the *there* type or of the *il* type, and that is all that should be relevant on Chomsky's account.

¹⁸ Chomsky in fact notes that "...the French examples...have a more equivocal status than in the idealization here." [p.384]

¹⁹ I postpone for another occasion considerations of 'reconstruction': essentially, the question of whether there is licensing *prior* to S-structure.

is exactly in accord with that of Chomsky (1981), though now for a somewhat different reason. Then, it was because, by stipulation, the licensing conditions had to be satisfied at S-structure. Such a stipulation is unavailable within the Minimalist framework. Instead, there is the independently plausible asymmetry between covert movement (strictly of formal features) and overt movement (of an entire category, via pied piping). Under the assumption that these licensing phenomena involve referential and quantificational properties, and not just formal features, the correct result is obtained.²⁰ For control, a phenomenon that might or might not involve c-command, the pattern is apparently different in certain respects. Whether its licensing is as expected under LF feature movement remains to be determined.

²⁰ Another possibility consistent with the facts examined here is that what is at issue is not formal licensing but rather interpretation. Earlier approaches to anaphora, such as RI of Chomsky (1973) and the disjoint reference rule of Lasnik (1976), utilized interpretive rules rather than syntactic filters or licensing conditions. Chomsky and Lasnik (1993) suggest that such an approach should be resurrected.

References

- Barss, Andrew. 1986. Chains and anaphoric dependence: On reconstruction and its implications. Doctoral dissertation. Cambridge, Mass.: MIT.
- Belletti, Adriana. 1988. The Case of unaccusatives. *Linguistic Inquiry* 19. 1-34.
- Chomsky, Noam. 1973. Conditions on transformations. In Stephen R. Anderson & Paul Kiparsky (eds) *A Festschrift for Morris Halle*. New York: Holt, Rinehart & Winston. 232-286.
- Chomsky, Noam. 1981. *Lectures on government and binding*. Dordrecht: Foris.
- Chomsky, Noam. 1986a. *Knowledge of language*. New York: Praeger.
- Chomsky, Noam. 1986b. *Barriers*. Cambridge, Mass.: MIT Press.
- Chomsky, Noam. 1991. Some notes on economy of derivation and representation. In Robert Freidin (ed.) *Principles and parameters in comparative grammar*. Cambridge, Mass.: MIT Press. 41-454. [Reprinted in Chomsky 1995].
- Chomsky, Noam. 1995. *The minimalist program*. Cambridge, Mass.: MIT Press.
- Chomsky, Noam & Howard Lasnik. 1993. The theory of principles and parameters. In Joachim Jacobs, Arnim von Stechow, Wolfgang Sternefeld & Theo Vennemann (eds) *Syntax: an international handbook of contemporary research*, volume I. Berlin: Walter de Gruyter. 506-569. [Reprinted in Chomsky 1995].
- Dikken, Marcel den. 1995. Binding, expletives, and levels. *Linguistic Inquiry* 26. 347-354.
- Groat, Erich. 1995. English expletives: a minimalist approach. *Linguistic Inquiry* 26. 354-365.
- Hornstein, Norbert. 1994. An argument for minimalism: the case of antecedent-contained deletion. *Linguistic Inquiry* 25. 455-480.
- Hornstein, Norbert & Amy Weinberg. 1990. The necessity of LF. *The Linguistic Review* 7. 129-167.
- Johnson, Kyle. 1991. Object positions. *Natural Language and Linguistic Theory* 9. 577-636.
- Kayne, Richard. 1994. *The antisymmetry of syntax*. Cambridge, Mass.: MIT Press.
- Koizumi, Masatoshi. 1993. Object agreement phrases and the split VP hypothesis. *MIT Working Papers in Linguistics*, Volume 18. 99-148.
- Koizumi, Masatoshi. 1995. Phrase structure in minimalist syntax. Doctoral dissertation. MIT, Cambridge, Mass.
- Larson, Richard K. 1988. On the double object construction. *Linguistic Inquiry* 19. 335-91.
- Lasnik, Howard. 1976. Remarks on coreference. *Linguistic Analysis* 2. 1-22. [Reprinted in Lasnik 1989.]
- Lasnik, Howard. 1989. *Essays on anaphora*. Dordrecht: Kluwer.
- Lasnik, Howard. 1992a. Two notes on control and binding. In Richard K. Larson, Sabine Iatridou, Utpal Lahiri & James Higginbotham (eds) *Control and grammar*. Dordrecht: Kluwer. 235-252.
- Lasnik, Howard. 1992b. Case and expletives: Notes toward a parametric account. *Linguistic Inquiry* 23. 381-405.
- Lasnik, Howard. 1993. Lectures on minimalist syntax. *UConn working papers; occasional papers in linguistics*.
- Lasnik, Howard. 1995a. A note on Pseudogapping. *MIT Working Papers in Linguistics*, Volume 27. 143-163.
- Lasnik, Howard. 1995b. Last resort and Attract F. *Proceedings of the Sixth Annual Meeting of the Formal Linguistics Society of Mid-America*, Volume I. 62-81.

- Lasnik, Howard. 1995c. Case and expletives revisited: On greed and other human failings. *Linguistic Inquiry* 26. 615-633.
- Lasnik, Howard & Mamoru Saito. 1991. On the subject of infinitives. *Papers from the 27th regional Meeting, Chicago Linguistic Society*. 324-343.
- Martin, Roger. 1992. Case theory, A-chains, and expletive replacement. Manuscript. University of Connecticut, Storrs, Conn.
- May, Robert. 1985. *Logical Form*. Cambridge, Mass.: MIT Press.
- Postal, Paul. 1974. *On Raising: one rule of English grammar and its theoretical implications*. Cambridge, Mass.: MIT Press.
- Uriagereka, Juan. 1988. On government. Doctoral dissertation. University of Connecticut, Storrs.
- Wyngaerd, Guido Vanden. 1989. Object Shift as an A-movement rule. *MIT Working Papers in Linguistics*, Volume 11. 256-271.
- Zwart, C. Jan-Wouter. 1993. Dutch syntax. A minimalist approach. Doctoral dissertation. University of Groningen.
- Zwart, C. Jan-Wouter. 1997. *Morphosyntax of verb movement. A minimalist approach to the syntax of Dutch*. Dordrecht: Kluwer.

On the Syntax of Local and Logophoric Control

Seth A. Minkoff

1 Introduction: local vs. logophoric control*

The controllers in (1) - (6) are free to be animate or not so.¹

- (1) a *The wind* blew little bits of hail all morning, only *PRO* to calm down later in the day.
b *Mary* blew little bits of hail all morning, only *PRO* to calm down later in the day.
- (2) a *The jell-o* fell off the table, (only) *PRO* to land with a thud on the floor below.
b *Mary* fell off the table, *PRO* to land with a thud on the floor below.
- (3) a (By remote control) *Mary* made *the car* switch into low gear *PRO* to get over the hill.
b *Mary* made *John* switch into low gear *PRO* to get over the hill.
- (4) a *Mary* put *the towel* in the sun *PRO* to warm up.
b *Mary* put *John* in the sun *PRO* to warm up.
- (5) a *Mary* put *the bookcase* in the living room *PRO* to hold her books for her.
b *Mary* put *her son* in the living room *PRO* to hold her books for her.

* I am grateful to the following people, from whose comments this work has benefitted: Noam Chomsky, Ken Hale, Marco Haverkort, Irene Heim, Howard Lasnik, Victor Manfredi, Alec Marantz, Shigeru Miyagawa, Carol Neidle, Orin Percus, David Pesetsky, Eric Reuland, Höskuldur Thráinsson, and participants in the Leiden Workshop on Atomism and Binding. Thanks also to Julia Collins and Jennifer Horan.

¹ Italics indicate relations of binding or control. Indices are added for clarity as needed.

- (6) a Mary sent *her shoes* to the shop *PRO* to be treated by a professional.
 b Mary sent *her son* to the shop *PRO* to be treated by a professional.

On the other hand, the controllers in (7) - (10) necessarily are animate; if these are made inanimate, as in each of the 'b' cases, the control relation becomes unacceptable:

- (7) a Mary made *John_i* move the stool_j onto the floor [*O_i PRO_i* to stand on *t_j*].²
 b *Mary made *the air blower_i* move the stool_j onto the floor [*O_i PRO_i* to stand on *t_j*].
- (8) a *PRO* to get washed, Mary sent *her son* to the shop.
 b **PRO* to get washed, Mary sent *her car* to the shop.
 (cf. Mary sent *her car* to the shop *PRO* to get washed.)
- (9) a *PRO* to wind down, Mary put *John* in the bathtub.
 b **PRO* to wind down, Mary put *the alarm clock* in the bathtub.
 (cf. Mary put *the alarm clock* in the bathtub *PRO* to wind down.)
- (10) a Mary sent the platform_i to *the doctor_j* [*O_i PRO_i* to stand on *t_j*].
 b *Mary sent the platform_i to *the house_j* [*O_i PRO_i* to stand on *t_j*].

I will argue that the control relations in (1) - (6), i.e. those dependencies that do not require animacy, are licensed by Condition A. Since Condition A is a purely structural principle, no semantic requirement is made of the controller: It is free to be animate or not. The control relations in (7) - (10) violate Condition A. This point is demonstrated by the necessity of animacy in the antecedents: The acceptability of a dependency that satisfies Condition A never would depend upon the semantic character of its antecedent.

Previous authors have used the term 'logophoric' to characterize certain dependencies that violate certain locality constraints. For example, Reinhart & Reuland (1993), among others, characterize as logophoric certain binding relations that violate Condition A;³ And Williams (1992) employs the term to characterize certain control relations that violate another principle of locality, Williams' notion of 'control by direct predication'.

² I assume that a control relation holds between the matrix-clause Theme and an operator raised from the object of the infinitival clause (in the spirit of Chomsky 1981). See note 20.

³ Cf. also Clements (1975); Zribi-Hertz (1989); Abe (1992).

As I understand these works, they suggest that certain dependencies that are deemed 'logophoric' can somehow reach beyond certain local domains if their antecedents are, to quote Sells (1987), "the source of [a] report, the person with respect to whose consciousness (or 'self') [a] report is made [or] the person from whose point of view the report is made [PIVOT]."

I believe that logophoric dependencies have been mischaracterized. First, I claim that the necessity of animacy characterizes logophoricity more accurately than do the narrower criteria advanced by Sells and others. In particular, I assume (11).

- (11) All control relations that impose semantic requirements (e.g. animacy) on their antecedents fail to be licensed by Condition A and are logophoric,^{4,5} and all control relations that do not impose semantic requirements (e.g. animacy) on their antecedents are licensed by Condition A.⁶

I will employ (11) to show that control relations are subject to Condition A; Condition A itself is reformulated along lines related to those proposed in Minkoff (1994). (Also, see that work for arguments that Condition A, properly formulated, constrains the binding of SELF-NPs as well as control.)

Further, I will argue that logophoric control has a structural basis. Such control is licensed by certain semantic (or 'thematic') roles on antecedents; these roles are produced by the application of a semantic interpretation which is itself constrained by abstract syntactic principles. (See Minkoff (1994), where an earlier version of the proposals developed here are extended to cases of logophoric binding of SELF-NPs.)

⁴ See Minkoff (1994) for discussion of logophoric SELF-NP binding dependencies that impose a semantic requirement other than animacy on their antecedents.

⁵ Obviously, this statement applies only to cases in which the semantic requirement follows from the character of the dependency in question. For example, the necessity of animacy in (i) - (ii) does not necessarily imply logophoricity since, in this instance, animacy is selected due to a lexical idiosyncrasy of the verb.

(i) Mary kissed herself.

(ii) *The rock kissed itself.

⁶ In principle, a control relation may be both logophoric and in compliance with Condition A; but I will not pursue this point here.

2 Certain semantic relations license logophoric control

From what I've said so far, one might suspect that logophoric control is licensed by the animacy of the antecedent. However, this cannot be correct, because it fails to predict the behavior of (12) and (13), as well as of (7) - (10), above: In each of these cases, what seems to be required is not animacy per se, but, rather, the presence of a semantic role that happens to entail animacy on the part of the antecedent argument.

In (12a), where logophoric control is permitted,⁷ the controller, the matrix Theme, is understood to go intentionally to the chef. Hence, I refer to this argument as a 'Volunteer', which is a species of Theme. In (12b), the controller is not understood to go to the chef intentionally; hence this argument, though still a Theme, and still animate, is not a Volunteer — and, here, the logophoric dependency is blocked. Thus, the Volunteer role licenses logophoric control.⁸

- (12) a *PRO* to get a good meal, I sent *my son* to the chef.
 b **PRO* to get a good meal, I sent the chef *my son*.

Lest one suspect that the contrast in (12) turns on the use of the double-object structure independently of the semantic role of the antecedent, the same contrast can be discerned in (13).

⁷ Some speakers seem to reject fronted infinitival clauses of this kind, for reasons having nothing to do with logophoricity. What matters for the current discussion is that speakers who accept (12a) nonetheless reject (12b).

⁸ On closer examination, the Volunteer role involves a property that is broader than the mere intention suggested by (12a-b). For example, Carol Neidle has pointed out to me the acceptability of sentences along the lines of (i).

- (i) *PRO* to get her shots, I brought *my cat* to the veterinarian.

On the ordinary reading of this example, my cat does not, in fact, go intentionally to the veterinarian. I believe that, in truth, a Theme is a Volunteer just if the entity responsible for causing the event in which that Theme participates believes that the Theme's interests could be (seen to be) served by its going to the Goal in question. So, for example, (i) is acceptable because I, the Agent, believe that my cat's interests could be (seen to be) served by her going to the veterinarian. This point is confirmed by the fact that the control relation in (ii), though structurally parallel to that in (i), is unacceptable if I believe that my cat is dead and hence without any possible interests.

- (ii) **PRO* to get buried, I brought *my cat* to the grave digger.

See Minkoff (1997a) for further discussion of the Volunteer role.

- (13) a *PRO* to scrub down, Mary put *John* in the bathtub.
 b **PRO* to die, Mary put *John* in the bathtub.

In (13a), where logophoric control is permitted, the controller, the matrix Theme, is understood to go intentionally into the bathtub, with the intention of scrubbing down. Hence here, as in (12a), this argument is a 'Volunteer', a species of Theme.

On the other hand, given the usual pragmatics, the controller in (13b) is not understood to go into the bathtub intentionally; hence this argument, though still a Theme, and still animate, is not a Volunteer — and, here, the logophoric dependency is blocked. Note that, if one assumes that John in fact intends to get into the bathtub to die, then the Theme acquires the Volunteer role and (13b) becomes perfectly acceptable. Thus, it seems clear that the Volunteer role licenses logophoric control. The circumstances of (8a) and (9a) are identical to those of (12a) and (13a) in all the relevant respects. I leave verification of this point to the reader.

In (10a), where logophoric control is permitted, the controller, the matrix Goal, is understood to take possession of the platform. I refer to this argument as a 'Beneficiary', which is a species of Goal.⁹ While I know of no way to block the Beneficiary reading here so as to tease apart the influences of thematic relations and animacy, (14a-b) seem to make it clear that neither the argument structure of the matrix, nor the animacy of the controller itself, makes the Beneficiary reading necessary.

- (14) a Mary sent John to *the doctor*.
 b Mary sent the platform to *Chicago*.

Thus, the necessity of the Beneficiary reading in (10) seems to follow because this role licenses logophoric control.

Next, in (7a), where logophoric control is permitted, the controller, the Causer of the first embedded clause, must be understood to act intentionally. I refer to this argument as an 'Agent', which is a species of Causer.¹⁰ While I know of no way to block the Agent reading here so as to tease apart the influences of thematic relations and animacy, (15a-b) seem to make it clear that neither the argument structure of the

⁹ See Minkoff (1997a) for a somewhat expanded discussion of the Beneficiary role.

¹⁰ Note that, since John is not the matrix clause Agent, there is no danger that the obligatory status of his agency could be due to the purposive nature of the sentence in question.

controller's clause, nor the animacy of the controller itself, makes the Agent reading necessary.¹¹

- (15) a *John* moved the stool onto the floor.
 b *The wind* moved the stool onto the floor.

Thus, the necessity of the agent reading in (7) seems to follow because this role licenses logophoric control.

Table 1 summarizes what has been shown so far regarding which thematic relations license logophoric control.

Table 1

	AGENT	VOLUNTEER	BENEFICIARY
Licenses LOGOPHORIC CONTROL	YES (7a)	YES (12a), (13a)	YES (10a)

Each logophoric dependency — whether it be control by a Volunteer as in (12a) or (13a), by a Beneficiary as in (10a), or by an Agent as in (7a) — is licensed by the presence of a thematic role that entails animacy in the antecedent. I shall refer to these thematic roles — Volunteer, Beneficiary, and Agent — as 'logophoric roles'.¹²

¹¹ Note that I take an Agent to be an intentional Causer: The subject of (15a) need not be interpreted as an Agent, since it need not act intentionally.

¹² A reviewer has suggested that perhaps logophoric control is licensed, not by the presence of a logophoric role on the antecedent but, instead, by the presence of an Agent role on the controlled PRO. On this approach one would assume, for example, that in (13a) control is licensed by the presence of an Agent role on the PRO subject of *scrub down*, rather than by a logophoric role on the antecedent *John*; that in (10a) control is licensed by the presence of an Agent on the PRO subject of *stand on*, rather than by a logophoric role on the antecedent *the doctor*; and so on. I believe that (i) - (ii) pose counter examples to this proposal.

- (i) PRO to get her vaccinations, I bring *baby Sarah* to the best pediatrician in town.
 (ii) PRO to experience for herself the sensation of internal peace, I sent *Ann* to that retreat I was telling you about.

(i) is easily interpreted without baby Sarah functioning as an Agent. Indeed, this would seem the more natural reading, as very few babies would get vaccinated deliberately. Also, I believe that (ii) does not require Ann to function as an Agent, though this example is admittedly less clear. In addition, it seems

3 **Optionality of logophoric roles**

Now, from the standpoint of the argument structure of the matrix clause, the interpretation of a Theme as a logophoric role, i.e. as a Volunteer, or of a Goal as a logophoric role, i.e. as a Beneficiary, or of a Causer as a logophoric role, i.e. as an Agent, seems to be a purely optional matter. For example, consider again the sentence (12a). If this sentence's matrix Theme is released from the burden of logophoric control, it can freely be replaced by an inanimate NP as in (16).

(16) I sent *my food* to the chef.

This shows that the 'Volunteer-hood' of this Theme is in truth optional: Volunteer-hood never really was demanded by the argument structure in which the Theme participates.

The circumstances of (8a), (9a) and (13a), are identical to those of (12a) in all the relevant respects; I leave verification of this point to the reader. Similar remarks hold of the Goal in (10a). If this argument is released from the burdens of logophoric control, it can freely be replaced by an inanimate NP as in (17).

(17) Mary sent the platform to the house.

This shows that the 'Beneficiary-hood' of this Goal is in truth optional: Beneficiary-hood never really was demanded by the argument structure in which the Goal participates. Finally, similar remarks hold of the Causer in (7a). If this argument is

clear that the 'backwards' binders of SELF-NPs and reciprocals in (48a-c), discussed briefly in the text, also are not Agents. Minkoff (1994) argues that such binders, to succeed, must be interpreted as having the logophoric role Beneficiary. That work advances a broader theory of logophoric dependencies covering both binding and control. Adoption of the reviewer's proposal apparently would require the abandonment of such a theory.

I believe the reviewer may be responding to an underlying sense of there being a belief that the event in the infinitival clause could (be seen to) serve the interests of the controlling argument. This notion of '(presumably served) interests' seems to me to be inherent in each of the logophoric roles Volunteer, Beneficiary and Agent. If this is correct then, for example in (i), there is no need for an Agent role in the controlled PRO; instead, the relevant intuition is captured by the fact that there is a belief that baby Sarah's interests could be (seen to be) served by her getting her vaccinations. See Minkoff (1997a) for a more detailed exploration of the notion of 'interests' with respect to the Volunteer and Beneficiary roles.

released from the burden of logophoric control, it can freely be replaced by an inanimate NP, as in (18).

(18) Mary made *the air blower* move the stool onto the floor.

This shows that the 'Agent-hood' of this Causer is in truth optional: Agent-hood never really was demanded by the argument structure in which the Causer participates.

The discussion in this section indicates that the Volunteer, Beneficiary and Agent roles, which license logophoric control, represent optional ways of interpreting the broader thematic roles Theme and Goal and Causer, respectively. In other words, the Volunteer is an optional subcase of the broader Theme role, the Beneficiary is an optional subcase of the broader Goal role, and the Agent is an optional subcase of the broader Causer role. Now, following the spirit of Hale & Keyser (1991, 1993, 1994), and Jackendoff (1983, 1990) before them, I assume that the broader thematic roles Theme, Goal and Causer, are themselves entirely the product of syntax, specifically of argument structure.¹³ This is reasonable since, in each of the cases above, when the arguments in question are stripped of the burden of logophoric control, and are made inanimate, they still remain obliged to fulfill their respective Theme, Goal, or Causer roles.

In view of these assumptions, the logophoric subcases of the broader thematic roles amount to optional subcases generated on configurationally determined roles. I propose that these subcases are the output of a single optional semantic interpretation applied to syntax. The relationship between semantic interpretation and syntax is as stated in (19).¹⁴

(19) Syntactic configuration generates:

- (a) the sense of Theme-hood, onto which a semantic interpretation overlays 'logophoricity', and hence (here) the sense of Volunteer-hood;
- (b) the sense of Goal-hood, onto which a semantic interpretation overlays 'logophoricity', and hence (here) the sense of Beneficiary-hood;

¹³ Therefore one might assume, as do Hale and Keyser, that these thematic roles have no independent theoretical status.

¹⁴ A priori, one might well question whether distinctions between Theme and Volunteer, Goal and Beneficiary, and Causer and Agent, deserve a place within linguistic theory. However, I believe such distinctions are vindicated by the current work. (See also Minkoff 1994; in addition, see Lasnik 1988 for a brief discussion of the question of Agent vs. Causer)

- (c) the sense of Causer-hood, onto which a semantic interpretation overlays 'logophoricity', and hence (here) the sense of Agent-hood.

I will continue to refer to Agents, Volunteers and Beneficiaries as 'logophoric roles', and as 'species' of the broader 'thematic roles' Causer, Theme and Goal. The term 'logophoric role' is not meant in any way to equate the theoretical status of logophoric and thematic roles; it is used only as a shorthand for the product of thematic roles, which are a reflex of syntax, and logophoricity, which is overlaid by semantic interpretation.

I argue that the logophoric sense which is generated by the semantic interpretation is responsible for the licensing of logophoric control. Since logophoricity is the only means by which a control relation can successfully violate Condition A, and since logophoricity entails animacy on the part of the antecedent argument, it follows that animacy always will be necessary for the rescue of control that violates Condition A, and never will be called for by control that obeys Condition A.

In the remainder of this article, I will give an answer to the following two questions, in (A) and (B):

- (A) What qualifies as a local domain, i.e., what syntactic relation has to hold between the controller and controllee in order for the dependency to be in compliance with Condition A, and therefore exempt from the need of any logophoric role (and hence exempt from any need of animacy)?
- (B) Where can logophoric roles be generated? In other words, what syntactic constraints govern the application of the semantic interpretation responsible for logophoric roles?

4 The local domain

I assume that branching is limited to binary along the lines proposed in Larson (1988) (also cf. Kayne 1984), and I also assume the VP-internal subject hypothesis so that, for example, (20) has the D-structure shown in (21).

- (20) Mary folded the blanket under the shelf.

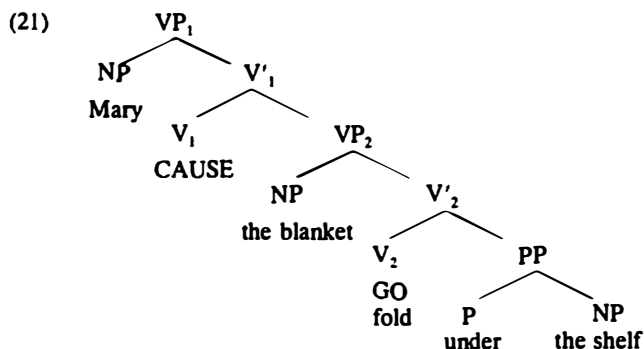

In addition I assume, following the spirit of Hale & Keyser, and other authors, that, as a result of this syntactic structure, the verbal heads of (21) acquire the meanings expressed in capital letters. So, in other words, the structure of (21) generates the sense that *Mary CAUSES the blanket to GO under the shelf*. Further, I make what I believe to be the intuitively natural assumption that, in a structure such as (21), the elements V'_1 , V'_2 , and PP are predicates; and all other elements in (21) are non-predicates.¹⁵ Finally, I propose that the minimal non-predicate constitutes a local domain for control into infinitival clauses. In other words, Condition A is formulated as shown in (22). (See Minkoff 1994 for a related version of this proposal that applies both to control and to the binding of SELF-NPs.)

- (22) **Condition A:** Any PRO 'X' can be successfully bound by any NP 'Y', provided Y and the minimal infinitival clause dominating X both are dominated by the same minimal non-predicate.

Now, the limitation on control relations with which this article began, namely that certain controllers can be inanimate while others cannot be, will fall out in a natural way. However, first I must develop plausible assumptions about where the infinitival clause attaches to the matrix: without such assumptions, no interesting claims can be made about the nature of locality. I assume that the attachment site of the infinitival clause can be discerned by semantic relations that hold between the infinitival and matrix clauses. Specifically I assume (23):

¹⁵ I assume that, in any sentence, an element is a predicate just if it is predicated of some subject.

- (23) **Purpose Attachment Principle:** An infinitival clause 'X' is attached within a VP 'Y' in D-structure if and only if the event expressed by Y is for the purpose expressed by X.

Now, the logophoricity (and hence animacy) facts about control are as predicted by Condition A. For example, the control relation in (4a) is licensed by Condition A, and so it is correctly predicted that control does not need to be "rescued" by a logophoric role (nor, hence, animacy) on the controller. (23) holds that the infinitival clause *to warm up* (the instantiation of 'X') is attached within the VP *the towel GOES in the sun* (the instantiation of 'Y'), since *the towel GOES in the sun for the purpose of warming up*. Thus, (4a) is structured as in (24). (For the sake of argument, I assume that the infinitival clause adjoins to the relevant VP.)¹⁶

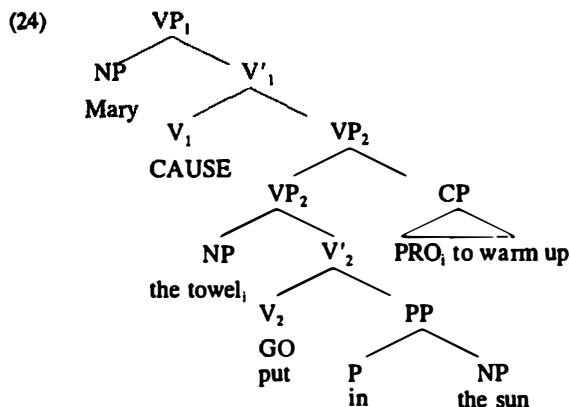

Control complies with Condition A since the infinitival clause and the controller, the matrix direct object *the towel*, both are within the same minimal non-predicate, namely VP_2 . The circumstances of (5a) and (6a) are identical to those of (24) (= 4a), as I leave it to the reader to verify. Next, consider the behavior of (25).

- (25) (By remote control) *Mary made the car drop its ballast onto the road*
[*PRO to get over the hill*].

¹⁶ Note that nothing I will say depends upon adjunction to VP being the precise means of attachment — though, of course, the notion of an infinitival clause's being attached *within* a constituent must now be understood to include the possibility of its being adjoined to it. Also, 'c-command' must be defined so that, for example in (24), *the towel* c-commands the infinitival clause.

Here again, control is licensed by Condition A, and so again it is correctly predicted that control need not be rescued by a logophoric role (nor, hence, animacy) on the controller. (23) holds that the infinitival clause *to get over the hill* ('X') is attached within the VP *the car CAUSES its ballast to GO onto the road* ('Y'), since *the car CAUSES its ballast to GO onto the road for the purpose of getting over the hill*. At the same time note that, in (25), *its ballast* does not *GO onto the road for the purpose of (the car's) getting over the hill*.¹⁷ Given this fact, it follows by (23) that the infinitival clause *to get over the hill* cannot be attached within the VP *the ballast GOES onto the road*. Thus, (25) must be structured as shown in (26): the only possible site of attachment for the infinitival clause is in the VP headed by CAUSE, not by GO.

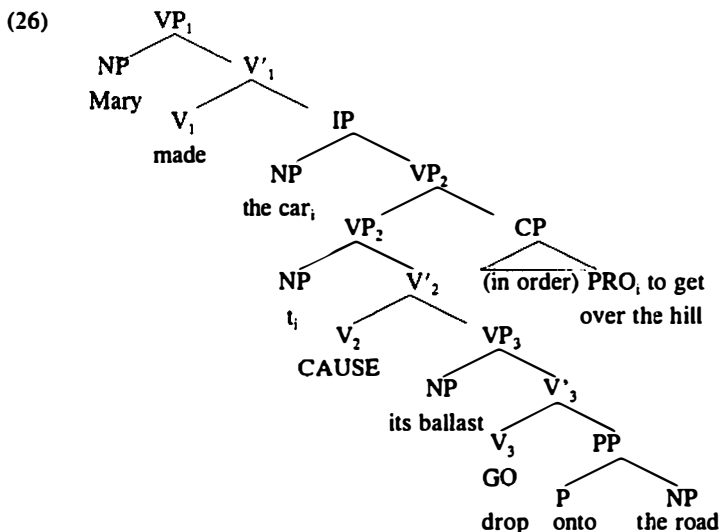

¹⁷ Of course, (25) could in fact be used to describe a situation in which Mary indeed intends that the ballast should GO onto the road for the purpose of (the car's) getting over the hill. However, this is in no way an entailment of the sentence. In other words, (25) can easily describe a situation in which Mary intends that the purpose in question should be served by the act of "dropping," but not by the ballast's ultimate trajectory. For example, one can take the sentence to mean that in Mary's intentions, the car should gain the ability to climb the hill as soon as it has dropped the ballast, well before the ballast has actually GONE onto the road. Note how (25) contrasts in this respect with a case like (24) (= 4a), in which Mary has to intend that the towel should actually GO in the sun for the purpose of warming up. For example, one cannot take (24) to mean that, in Mary's intentions, the towel would gain the ability to warm up as soon as she had started to move it, before it actually got into the sun.

Here, the control relation complies with Condition A since the infinitival clause and the controller, the trace of the embedded subject *the car*, both are within the same minimal non-predicate, namely VP₂.¹⁸ The circumstances of (3a) are identical to those of (25); I leave verification of this to the reader.

Finally, consider the behavior of (1a). Here, once again, control is licensed by Condition A, and thus, once again, it is correctly predicted that control need not be rescued by a logophoric role (nor, hence, animacy) on the controller. (23a) holds that the infinitival clause *to calm down later in the day* ('X') cannot be attached within the VP *the wind blew little bits of hail all morning* ('Y'), since *the wind doesn't blow little bits of hail all morning for the purpose of calming down later in the day*. Given this fact, the only possible site of attachment for the infinitival is within IP, yielding a structure along the lines of (27).

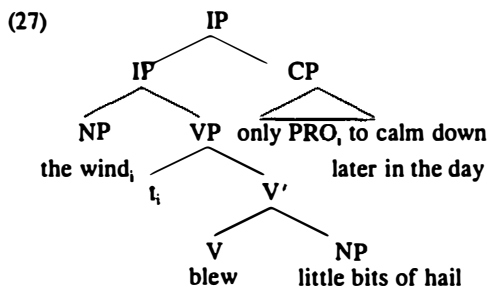

Here, control complies with Condition A, since the infinitival and the controller, the matrix subject *the wind*, both are within the same minimal non-predicate, namely the matrix IP.¹⁹ The circumstances of (2a) are identical to those of (1a), so I omit discussion of them here.

So far, I have shown that control relations are licensed by Condition A in (1) - (6) and in (25), and I have shown how this analysis correctly predicts that no logophoric role, nor hence animacy, will be required on the controller. Next I will show that Condition A fails to license control relations in (7) - (10), and I will show how this analysis correctly predicts the necessity of logophoric roles, and therefore of animacy, in the controllers of these sentences.

¹⁸ Obviously, given the VP-internal subject hypothesis, I must assume that trace (as well as overt NP) can control.

¹⁹ Note that, if the infinitival clause were attached to VP in (27), the control relation still would comply with Condition A. However, in order for the sentence to have this structure, it would have to mean that the wind blew little bits of hail all morning for the purpose of calming down later in the day.

First, Condition A fails to license control in (7a-b). In the acceptable example (7a), the infinitival clause *to stand on* is attached within the VP *the stool GOES onto the floor*, since *the stool GOES onto the floor for the purpose of (John's) standing on (it)*. Therefore, by (23), (7a) is structured along the lines of (28).²⁰

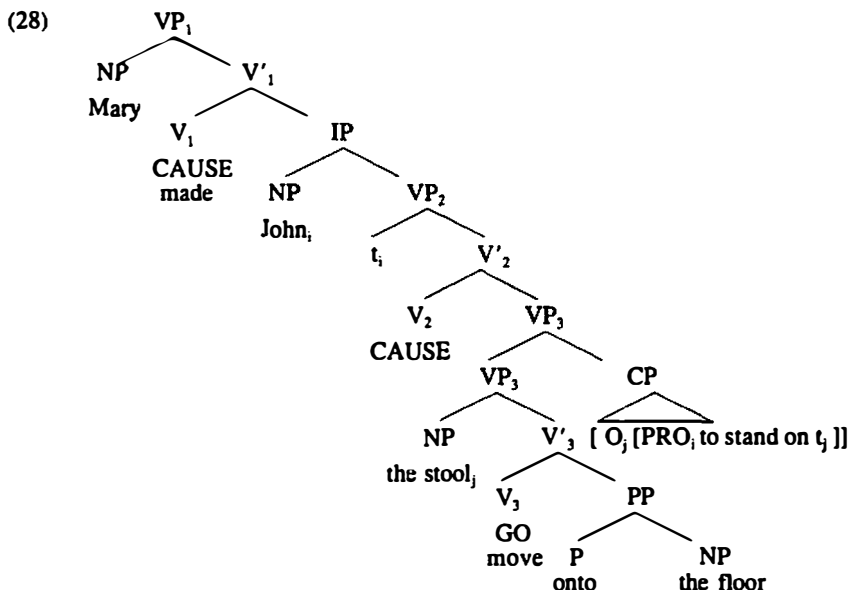

Here, the infinitival, but not the controller, is within the non-predicate constituent VP_3 ; hence control cannot be licensed by Condition A. Consequently, if control is to succeed, it must be licensed logophorically (by an Agent role on the controller). From this it is correctly predicted that, when the creation of a logophoric role is blocked by the substitution of an inanimate NP, as in (7b), the would-be control relation becomes unacceptable.

²⁰ Minkoff (1994) argues that the (operator raised from the) object position is controlled in compliance with Condition A (and hence need not be animate). In the terms of the current work, this follows since the controller and infinitival clause are within the same minimal non-predicate. Indeed, one might assume that the raised element is itself a PRO, as in Chomsky 1981; however, I retain the operator notation here, since the current discussion focuses only on control of the subject. (Also, see the above cited work for discussion of interactions between control of subject and control of object.)

Next, consider (8). Here, the infinitival has been fronted, presumably from a base position in which it was adjoined to the lower VP. On the assumption that the fronted infinitival attaches to IP, (8a) has the structure shown in (29).

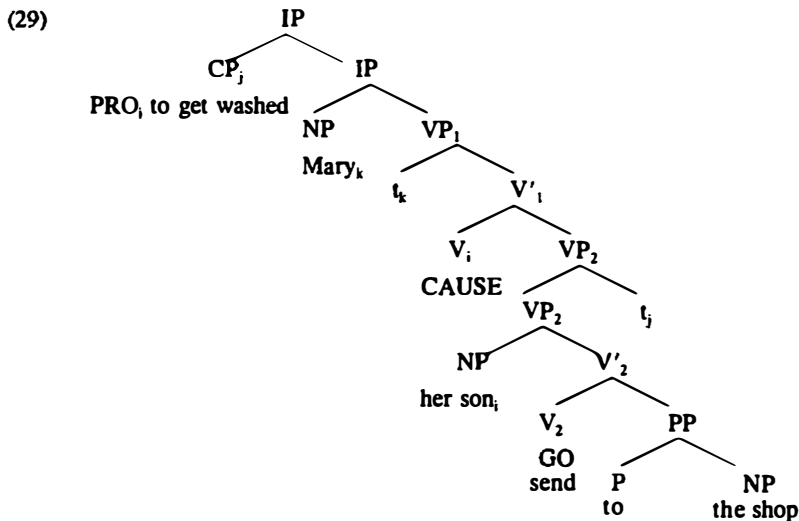

Here, again, control is not licensed by Condition A, this time due to the fact that the controller, but not the infinitival, is within the non-predicate constituent VP₂. As a consequence, control can succeed here only if it is licensed logophorically (by a Volunteer role on the controller).²¹ From this it is correctly predicted that, when the creation of a logophoric role is blocked by the substitution of an inanimate NP, as in (8b), the would-be control relation becomes unacceptable. The circumstances of (9a-b) are identical to those of (8a-b), as I leave it to the reader to verify.

Finally, consider (10). In the acceptable example (10a), the infinitival clause *to stand on* is attached within the VP *the platform GOES to the doctor*, since *the platform GOES to the doctor for the purpose of standing on*. Hence, (10a) has the structure shown in (30).

²¹ I do not rule out the possibility that PRO might be controlled in its base position (within VP²) in compliance with Condition A. However, this still leaves PRO with no 'Condition-A-compliant' controller at S-structure, and this evidently is sufficient to create a need for 'rescue' via logophoric control.

(30)

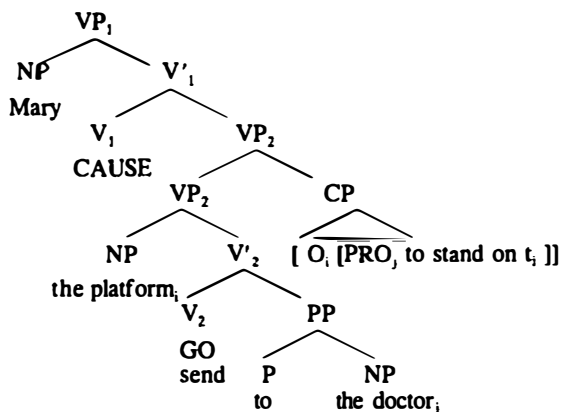

Here, once again, control (of the embedded subject) is not licensed by Condition A, though the reason for this is different from in the other cases. Here, the infinitival and its antecedent in fact are within the same minimal non-predicate, namely VP₂; however, the controller fails to c-command the infinitival clause, and therefore control in compliance with Condition A is impossible. So, since the control relation in (30) violates Condition A, it is correctly predicted that, when the creation of a logophoric role is blocked by the substitution of an inanimate NP, as in (10b), the would-be control relation becomes unacceptable.

Now I have shown that control relations are not licensed by Condition A in (7) - (10), and I have shown how this analysis correctly predicts the necessity of logophoric roles, and therefore of animacy, in the controllers of these sentences. Overall, the discussion in this section has shown that, when the local domain for Condition A is taken to be the minimal non-predicate dominating both the controller and the infinitival clause, and given reasonable assumptions about the infinitival clause's site of attachment, a contrast falls out automatically between those control relations that do, and those that do not, require a logophoric role, and hence animacy, on the controller.

5 How the generation of logophoric roles is constrained by syntax

Now it is clear what constitutes a local domain. And it is clear that, when this local domain is overreached, control can be rescued by the presence of a logophoric role on the antecedent. Also, it is clear that logophoric roles themselves are produced by the application of a semantic interpretation to syntax; the logophoric role is an

interpretive subcase of a broader thematic role that is itself a reflex of syntactic configuration. It remains to be shown how this semantic interpretation works. What kinds of syntactic configurations can it apply to? How is the generation of logophoric roles constrained? I will show that logophoric roles (i.e. the roles that license logophoric control) are generable only in syntactic positions that satisfy certain structural criteria.

I already demonstrated examples of the positions in which logophoric roles can be generated, when I detailed the array of roles that can license logophoric control. These were summarized in table 1. In syntactic terms, table 1 represents the fact that logophoric roles can be generated in the positions listed in (31).

- (31) *Agent*
 the subject of a transitive (e.g. (7a))
Volunteer
 the direct object of a transitive with a PP complement (e.g. (12a), (13a))
Beneficiary
 the oblique object of a transitive with a PP complement (e.g. (10a))

If this information is reorganized according to sentence structure, the possibilities for generating logophoric roles are distributed as listed in (32).

- (32) *TRANSITIVE*
 subject
 oblique object
 direct object, if there's a PP complement

Now, reviewing these options, one finds a gap, as stated in (33).

- (33) The generation of a logophoric role has not been demonstrated in the direct object of a simple transitive (i.e. in the object of a transitive with no PP complement).

It turns out that logophoric roles cannot be generated in this position. This is demonstrated by the unacceptability of (34) - (36).

- (34) *(In order) *PRO* to get washed, the kidnapper took *Mary and John*.
 (35) *(In order) *PRO* to get washed, Mary got *John*.
 (36) *(In order) *PRO* to get washed, Mary moved *the creature*.

Note that, in these instances, the would-be controllers are animate. Thus, the problem with these cases seems not to be the lack animacy but, rather, the lack of a logophoric role. Specifically, all these controllers are Themes, but they lack the Volunteer role (which, if it were available here, would be the logophoric subcase of the Theme). In other words, for example, one cannot interpret (34) to mean that Mary and John intentionally GO to the kidnapper; one cannot interpret (35) to mean that John intentionally GOES to Mary; and one cannot interpret (36) to mean that the creature intentionally GOES where Mary moves it.

Furthermore, note that, for each of (34) - (36), additional syntax can be inserted so that the Volunteer role becomes permissible, and then the logophoric dependency becomes permissible also, as shown in (37) - (39).

- (37) (In order) *PRO* to get washed, the kidnapper took *Mary and John* to the lake.
 (38) (In order) *PRO* to get washed, Mary got *John* to the lake.
 (39) (In order) *PRO* to get washed, Mary moved *the creature* into the bathroom.

I propose that the distribution of positions in which logophoric roles can and cannot be generated is due to the principle stated in (40):

- (40) In order for an argument 'X' to receive a logophoric role, X must occupy the highest theta position within a maximal projection.

(40) correctly predicts that the subject of a transitive can receive a logophoric role, since that argument occupies the highest theta position within the VP. Moreover, if the transitive has a PP complement, (40) correctly predicts that its direct object can receive a logophoric role, since the direct object then occupies the highest theta position within the lower VP. This can be seen, for example, in (29). Further, if the transitive has no PP complement, (40) correctly predicts that its direct object cannot receive a logophoric role, since then the direct object does not occupy the highest theta position in any maximal projection. This can be seen in (41).

(41)

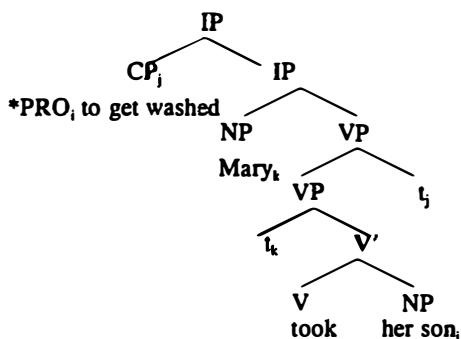

And finally, if the transitive does have a PP complement, (40) correctly predicts that its oblique object also can receive a logophoric role since then that argument occupies the highest theta position within the PP. This can be seen, for example, in (30).

Now let me demonstrate another gap: A logophoric role cannot be generated in the direct object of a transitive verb with an adjectival complement, as in (42a-b).

- (42) a *PRO to resist pneumonia, Mary got John warm.
 (Cf. Mary got John warm PRO to resist pneumonia.)
- b *PRO to avoid getting a sunburn, Mary painted John white.
 (Cf. Mary painted John white PRO to avoid getting a sunburn.)

I assume, following Hale & Keyser, that transitive verbs with adjectival complements are structured as shown in (43).

(43)

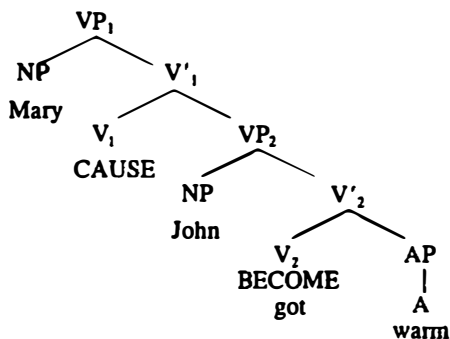

And I assume, following the spirit of Hale & Keyser, that, as a result of this syntactic structure, the verbal heads of (43) acquire the meanings expressed in capital letters, so that (43) expresses the meaning that *Mary CAUSED John to BECOME warm*.

Now, on the assumption that the fronted infinitival adjoins to IP, (42a-b) have the structure shown in (44).

(44)

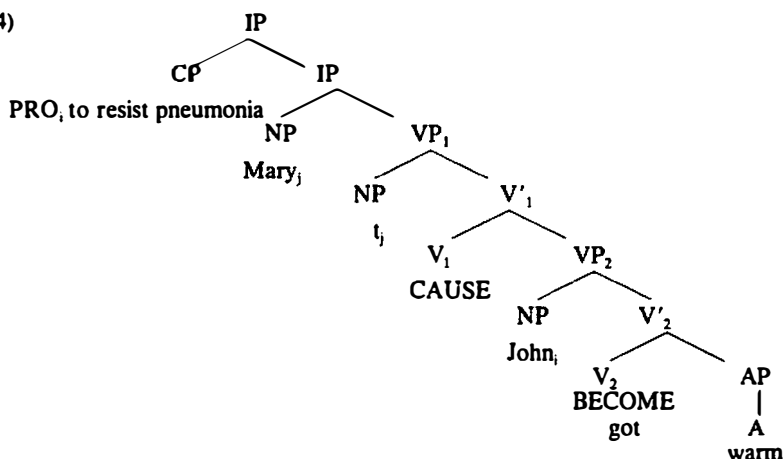

Here, the infinitival and the would-be controller *John* clearly are not within the same minimal non-predicate. Therefore, the only possible way this control relation could succeed would be logophorically. So, since the control relation is not in fact permitted, I conclude that the object of a transitive verb with an adjectival complement cannot, in fact, receive a logophoric role.^{22,23}

²² Indeed, I believe this result accords with one's intuitions regarding what such sentences can be interpreted to mean. Consider, for example, the matrix clauses of (42a-b), given here as (i) and (ii).

- (i) Mary got John warm.
 (ii) Mary painted John white.

My judgment is that, in these examples, the direct object cannot be interpreted as a Volunteer. In other words, (i) cannot mean that John is volitionally becoming warm; and (ii) cannot mean that John is volitionally becoming white.

²³ A reviewer points out that sentences like (i) - (ii) seem fairly acceptable, in apparent contradiction to claims made in this work.

- (i) PRO to get a better job, the plastic surgeon made *Bill* handsome.
 (ii) PRO to fight insomnia better, Mary got *Bill* comfortable.

However, these examples become acceptable to me only when the controller is misconstrued as the matrix-clause subject, in other words when the plastic surgeon and Mary are the ones who would get a better job and fight insomnia better, respectively. When one is forced to construe the matrix-clause object as the only possible controller, the sentences seem to become unacceptable as in (iii) - (iv).

I propose that the distribution of positions in which logophoric roles can and cannot be generated is constrained by the principle stated in (45).

- (45) In order for an argument 'X' to receive a logophoric role, there must be another argument within the same minimal non-predicate as X.²⁴

(45) correctly predicts that the direct object of a transitive with an adjectival complement cannot receive a logophoric role, even though this argument does occupy the highest theta position within the lower VP. The problem for this argument is that there is no other argument also within the same minimal non-predicate, i.e. also within the lower VP. The situation of these direct objects of adjectival complement sentences contrasts with that of the other kinds of examples I have discussed. For example, in a transitive with a PP complement, (45) correctly predicts that the subject can receive a logophoric role (and hence serve as a logophoric controller) since, I would argue, that argument actually has another argument within its minimal non-predicate: I believe this other argument is the entire lower VP. To see this, consider again (7a), whose structure was displayed in (28). In this example, I consider VP₃, which expresses the proposition *the stool GOES onto the floor*, to be the argument of V₂. This makes intuitive sense, since John is the Causer, and *the stool's going onto the floor* is the thing caused. So, since the controlling subject *John* has another argument within its minimal non-predicate, it is able to receive a logophoric role — and hence can serve as a logophoric controller.

Also, in a transitive with a PP complement, (45) correctly predicts that the direct object can receive a logophoric role (and hence serve as a logophoric controller) since that argument has another argument within its minimal non-predicate, namely the oblique object. This can be seen in (8a), whose structure was given in (29). Here, the direct object *Mary's son* and the oblique object *the shop* both are within the same minimal non-predicate, namely the lower VP. The circumstances of (9a) are identical to those of (8a) in all relevant respects; I leave verification of this to the reader.

- (iii) *PRO to get a better job for himself, Mary made Bill handsome.
(Cf. 'Mary made Bill handsome, to get a better job for himself.')
- (iv) *PRO to fight his (own) insomnia better, Mary got Bill comfortable.
(Cf. 'Mary got Bill comfortable, to fight his (own) insomnia better.')

If these judgments are as I suggest, then (i) - (ii) pose no problem for the proposals made in this work.

²⁴ Note that the 'local domain' at issue here is the minimal non-predicate — the same notion that underlies Condition A, stated in (22) in the text.

In addition, (45) also correctly predicts that, in a transitive with a PP complement, the oblique object can receive a logophoric role (and hence serve as a logophoric controller), since that argument has another argument within its minimal non-predicate, namely the direct object. This can be seen in (10a), whose structure was given in (30). Here, the oblique object *the doctor* and the direct object *the platform* both are within the same minimal non-predicate, the lower VP.

Now, in (46), I summarize what I have demonstrated so far about syntactic constraints on the generation of logophoric roles.

- (46) In order for an argument 'X' to receive a logophoric role, X must occupy the highest theta position within a maximal projection, and there must be another argument within the same minimal non-predicate as X.

Finally, let me demonstrate one or two more gaps: In a transitive with a PP complement, a logophoric role cannot be generated on both the direct and oblique objects at the same time. This can be seen in (47a-c), though the point requires some discussion.

- (47) a *PRO_i to get a good meal, Mary brought [a clone of *himself*]_i to *the chef*.
 b *PRO_i to get a good meal, Mary brought [some clones of *themselves*]_i to *the chefs*.
 c **PRO_i to get a good meal, Mary brought [some clones of *each other*]_i to *the chefs*.

First of all, as pointed out in Minkoff (1994), 'backwards' SELF-NP- or reciprocal-binding by the matrix Goal into the (matrix) Theme, as occurs in (48a-c), is licensed only if the Goal is interpreted as having the logophoric role Beneficiary. This is demonstrated by the contrast between (48a-c) on the one hand, and (48d-f) on the other.

- (48) a Mary brought [a picture of *himself*]_i to *the chef* PRO_i to serve as a talisman.
 b Mary brought [some pictures of *themselves*]_i to *the chefs* PRO_i to serve as talismans.
 c Mary brought [some pictures of *each other*]_i to *the chefs* PRO_i to serve as talismans.
 d (*)Mary brought [a picture of *himself*]_i to *the chef* PRO_i to dry off in the sun.

- e (*)Mary brought [some pictures of *themselves*]_i to *the chefs* PRO_i to dry off in the sun.
- f (*)Mary brought [some pictures of *each other*]_i to *the chefs* PRO_i to dry off in the sun.

In each of (48a-c), the matrix Goal is understood to take possession of the picture. In other words, the matrix Goal is a Beneficiary, which is a species of Goal. And, in each case, backwards binding is permitted. On the other hand, given the usual pragmatics, the matrix Goal in each of (48d-f) is not understood to take possession of the picture. In other words, the matrix Goal, though still a Goal and still animate, is not a Beneficiary. And here, in each case, the backwards binding is blocked. At the same time, one could assume that the chefs in (48d-f) in fact are taking possession of the pictures. For example, suppose that the chefs have some (admittedly peculiar) desire to acquire the pictures in question, and to watch them dry off in the sun. In this case, the Goal readily acquires the Beneficiary role, and (48d-f) become perfectly acceptable. Thus, it seems clear that the Beneficiary role indeed is what licenses the backwards binding.²⁵

Now, the unacceptability of (47a-c) can be explained in a natural way. The problem with these sentences is not that a logophoric role has been generated in an inherently impossible position (as was the case, for example, in (34-36) and (42-44) above). This much is clear since it already has been established that, in a transitive with a PP complement, a logophoric role can be generated on the direct object alone, as in the acceptable (49), or on the oblique object alone, as in the acceptable (10a) (= 30) and (48a-c), above.

- (49) *PRO* to get a good meal, Mary brought *the clone* to the chef.

Instead, I believe that the problem with (47a-c) is that, due to the co-occurrence of the control and backwards-binding dependencies, logophoric roles are being asked to do the impossible, namely to be generated in both the direct and oblique objects simultaneously. I propose that the distribution of positions in which logophoric roles can and cannot be generated is constrained by the principle stated in (50).

²⁵ Note that my analysis of backwards binding differs crucially from proposals developed by Pesetsky (1987), (1995); and Belletti & Rizzi (1988).

(50) In order for an argument 'X' to receive a logophoric role, the other argument in X's minimal non-predicate must not itself receive a logophoric role.

(50) suggests that logophoricity is a binary relation on arguments within a given minimal non-predicate: Given two such arguments, one can have a logophoric role if and only if the other does not.

I now formalize the observations I have made concerning where logophoric roles can be generated as the Logophoric Role Constraint (51).

(51) Logophoric Role Constraint

In order for an argument 'X' to receive a logophoric role:

- (a) X must occupy the highest theta position within a maximal projection; and
- (b) there must be another argument 'Y' within the same minimal non-predicate as X, where Y does not itself receive a logophoric role.

6 Conclusion

In conclusion, I have shown that control relations are of two kinds: Those that obey Condition A, and those that are logophoric. I have reformulated Condition A, establishing the minimal non-predicate as the local domain. This reformulation factors out the semantic effects of logophoricity (and therefore of animacy), and in this way captures the genuine structural basis of non-logophoric control. Logophoricity, the semantic ingredient added to produce logophoric roles, licenses dependencies irrespective of distance, and is produced by a semantic interpretation whose application is constrained by abstract syntactic principles.

References

- Abe, Jun. 1992. The awareness of *zibun* and logophoricity. Manuscript. Storrs, Connecticut: University of Connecticut.
- Belletti, Adriana & Luigi Rizzi. 1988. Psych-verbs and theta-theory. *Natural Language and Linguistic Theory* 6. 281-342.
- Chomsky, Noam. 1981. *Lectures on government and binding*. Dordrecht: Foris Publications.
- Clements, George. 1975. The logophoric pronoun in Ewe: Its role in discourse. *Journal of West African Linguistics* 10:2.
- Hale, Kenneth & Jay Keyser. 1991. On the syntax of argument structure. Cambridge, Mass.: Center for Cognitive Science, Massachusetts Institute of Technology.
- Hale, Kenneth & Jay Keyser. 1993. On the complex nature of simple predicators. Manuscript. Cambridge, Mass.: Massachusetts Institute of Technology.
- Hale, Kenneth & Jay Keyser. 1994. The limits of argument structure. Manuscript. Cambridge, Mass.: Massachusetts Institute of Technology.
- Jackendoff, Ray. 1983. *Semantics and cognition*. Cambridge, Mass.: MIT Press.
- Jackendoff, Ray. 1990. *Semantic structures*. Cambridge, Mass.: MIT Press.
- Kayne, Richard. 1984. *Connectedness and binary branching*. Dordrecht: Foris Publications.
- Larson, Richard. 1988. On the double object construction. *Linguistic Inquiry* 19. 325-381.
- Lasnik, Howard. 1988. Subjects and the theta-criterion. *Natural Language and Linguistic Theory* 6. 1-17.
- Minkoff, Seth. 1994. How some so-called 'thematic roles' that select animate arguments are generated, and how these roles inform binding and control. Cambridge, Mass.: Doctoral Dissertation. Massachusetts Institute of Technology.
- Minkoff, Seth. 1997a. Argument structure and animacy entailment. In A. Mendiko-Etxea & M. Uribe (eds) *Issues at the morphology-syntax interface*. Vittoria, Spain: Supplements of the international Journal of Basque Linguistics and Philology.
- Pesetsky, David. 1987. Binding problems with experiencer verbs. *Linguistic Inquiry* 18. 125-139.
- Pesetsky, David. 1995. *Zero syntax: Experiencers and cascades*. Cambridge, Mass.: MIT Press.
- Reinhart, Tanya & Eric Reuland. 1993. Reflexivity. *Linguistic Inquiry* 23. 657-720.
- Sells, Peter. 1987. Aspects of logophoricity. *Linguistic Inquiry* 18. 445-439.
- Williams, Edwin. 1992. Adjunct control. In Richard Larson, Sabine Iatridou, U. Lahiri, & Jim Higginbotham (eds) *Control and grammar*. Kluwer.
- Williams, Edwin. 1994. *Thematic structure in syntax*. Cambridge, Mass.: MIT-Press. Linguistic Inquiry Monograph 23.
- Zribi-Hertz, Anne. 1989. Anaphor binding and narrative point of view: English reflexive pronouns in sentence and discourse. *Language* 65. 695-726.



Logical Entailment and the Possessive Nature of Reflexive Pronouns

Gertjan Postma

1 Introduction

In the standard version of Binding Theory, those lexemes that exhibit locality restrictions are described as being anaphoric. Such anaphoric lexemes are considered syntactically atomic. Their specification as [+ana] is considered a result of a lexical process of feature assignment. Recently, some progress has been made in distinguishing local anaphors and long-distance anaphors in relation with their morphological complexity (Reinhart & Reuland 1994). Similarly, studies in grammaticalization report that emphatic reflexives are complex in many languages and derive from inalienable possessed nouns, usually bodyparts, often quite general ones, like 'soul'. For instance Sanskrit *atman*, Classical Arabic *nafs* are identical to a body part meaning 'soul/breath'. In Moroccan Arabic it is *ra:s* ('head'), cf. (1).¹

- (1) a ra?a-a nafs-a-hu fi: l-mir?a:t-i. (Classical Arabic)
saw-P3SM breath-ACC-him in-the-mirror-GEN
'He saw himself in the mirror.'
- b saf-t ra:s-i: fe-l-mra:ya. (Moroccan Arabic)
saw-1 head-my in-the-mirror
'I saw myself in the mirror.'

In the Creole of Guinea-Bissau, it is *kabesa* 'head'. In Hungarian it is *mag-* (<'body') (cf. Marác 1989:392). In other languages, this relation is more remote and (part of) the anaphor, henceforth SELF, is only etymologically related to a body part. The same is true for Dutch *zelf* and English *self* which are derived from *li:f* 'body' (cf. Dutch *lijf*,

¹ The choice of another body part is in principle free, but gives more marked results than those of (1a) and (1b) in the respective dialects. I owe these examples to Abdelmajiid Jahfa (pers. comm.).

German *leib* 'body') in which a possessive morpheme SE has been incorporated. Other languages, like Biblical Hebrew, circumscribe SELF with a body part that is most appropriate in the specific context (*lev* 'heart', *šesem* 'bones', etc.; Renan ([1858]1990:236), Lettinga (1992:42). The Haitian creole language circumscribes SELF with *tet* 'head' or *kadav* 'body', (Green 1988:459). This suggests that heavy reflexives have a structure that is similar to that of configurations involving inalienable possession (cf. Postma 1997b).

Within generative linguistics, Helke, as early as 1973, has argued that reflexives like *myself* are not simplex reflexive pronouns, but restricted possessive noun *phrases*, to be compared *my head* in *I nodded my head*. Restricted possessives are locally bound, i.e. they are anaphoric in nature. Analogously, SELF has, syntactically, the function of a restrictive possessive noun within the reflexive constituent.

- (2) a I saw my/*your-self.
b I nodded my/*your head.

The analogy of restrictive possessives and reflexives makes anaphora a *configurational* property, i.e. a property of the predicate + complement DP rather than of a noun phrase in isolation. By drawing attention to the anaphoric nature of restrictive possessives, Helke has put the problem of the source of anaphora on the generative agenda.

1.1 The syntactic nature of reflexivity

This issue was addressed on a more general level by Pica (1988). Pica questioned the way natural language expresses identity, e.g. in copula constructions and local reflexive constructions. Can we, Pica asks, directly predicate in natural language that something is identical to something else? Isn't it ruled out by Principle B of the Binding Theory? Pica states that predicating identity is not possible. Pica distinguishes identity in (3a/b) where the identity is predicated, from cases as in (3c) where identity is not predicated but presupposed.

- (3) a Oscar_i is the king_i.
b Oscar_i saw himself_i.
c Oscar_i said that he_i was tired.

According to Pica, the identities expressed in (3ab) are illusions of language. Instead, these constructions realize *approximations*. Considered in their atomic organization, they *approximate* identity through a possessive construction. I will refer to this view of identity in language as the Approximation Hypothesis. In order to see what it entails, consider (4), which can be viewed as the syntactic structure underlying (3b).

(4) Oscar saw his X. (with X a dummy possessum)

(4) represents a possessive structure with an unspecified body part. This structure does not violate Principle B in any way: in (4), *his* is not locally bound by *Oscar* because the minimal domain is the noun phrase. Moreover, if X is a body part, we can explain the anaphoric nature of this construction from the general anaphoric nature of inalienable possession constructions (cf. Burzio 1986, Guéron 1985). In view of the morphological structure of heavy reflexives, such a possessive analysis is rather plausible. Moreover, it is, as we have seen, supported by diachronic evidence.

1.2 The semantic nature of reflexivity

Although (4) solves the syntactic problems and the diachronic issues involved in (3b), it constitutes a problem from a semantic point of view, since the reflexive *himself* is not any longer synchronically interpreted as a possessive structure. How can the possessive semantics of the construction be neutralized? Obviously, the possessive analysis of heavy reflexives can only be pursued seriously when the semantic problem has been solved.

At first glance, one might think that the semantic mechanism of approximation is not difficult to imagine, given (4). A representation as in (5b) would do the job. (5) states that 'John saw a part of him holds true for any (relevant) part'.

- (5) a John saw himself.
 b For all X, X is a (relevant) part of John: John saw [John's X].

In order for the semantic formulation (5b) to be implemented in *syntactic* theory, we need the following:

(6) *Requirements:*

- a a mechanism of variable formation, which can be applied to the above context of part-whole predicates.
- b a mechanism of implicit quantification.

These mechanisms must be syntactic, not only because of the fact that they interact with syntactic phenomena such as locality, but also because Principle B is part of (morpho)syntax. Moreover, the mechanism to escape this principle, i.e. compounding anaphoric lexemes, is syntactic. Finally, in a variety of languages, object-shielding as a way to circumvent principle B, is dependent on the features person and gender (cf. Rosen 1990, and the references found there).

Even if we assume (5b) to involve the correct representations of identity, it should be clear that the mechanism of 'approximation' in inalienable possession constructions such as in (7a) is not *always* active, since a sentence like (7b) does not mean that x saw x.

- (7) a Peter saw himself. x saw x
 b Peter has seen his finger.
 x sees x's finger ≠ x sees x

In order for the Approximation Hypothesis to be viable at all, we must give a satisfactory answer to the question when this mechanism is activated and when it is blocked. It is likely that the mechanism of approximation is related to the fact that the possessum either remains abstract, or reduces to the meaningless possessum SELF in (5ab). In other words, dummy noun formation seems to play a role in the way in which the grammar construes the approximation expressed through anaphora.

In this paper, we will address the semantic consequences of the syntactic analysis of reflexives as (restricted) possessives. First we will give additional evidence for the possessive nature of heavy reflexive pronouns (section 2). In section 3, we discuss the mechanisms of variable formation or dummy formation (section 3.1), as well as implicit quantification over such syntactic dummies (section 3.2). Section 4 is the essential passage. It describes the logical mechanism how a predicate over a dummy possessee can, *by entailment*, be a predicate over the possessor.

2. Additional evidence for reflexives as possessives

2.1. Evidence from English

A synchronic argument for the possessive nature of reflexives comes from English. English has a set of genitive possessive pronouns, as given in (8). The structure of these possessives seems to require the overt realization of a dummy possessum, as the bracketing in (8e) shows. Significantly, the reflexive pronoun does not have such a counterpart (9a). It is realized as a bare reflexive pronoun in predicative position (9b). Semantically, the possessive reading of 'having control over' is present both in (8a-e) and (9b). This shows that (9b) is both syntactically and semantically parallel to (8a-e).

- | | | | |
|-----|----------------------------------|-----|--------------------------------|
| (8) | a You are entirely <i>mine</i> . | (9) | a *I am entirely [myself [s]]. |
| | b I am entirely <i>yours</i> . | | b I am entirely myself. |
| | c I am entirely <i>hers</i> . | | |
| | d You are entirely <i>ours</i> . | | |
| | e I am entirely [their [s]]. | | |

The fact that no possessive marker can be added to *myself* in (9) indicates that *myself* has internal structure. We conclude that the presence of a dummy possessee SELF must be visible to the syntax.

2.2 Evidence from Dutch

An additional argument for the possessive nature of the reflexive comes from Dutch. In the Dutch dialect of Amsterdam (possibly the Dutch general substrate), the reflexive is always realized as the possessive reflexive *eigen*, comparable to *own* in English.

- | | |
|------|---|
| (10) | a Jan heeft z'n eigen boeken nooit herlezen.
'John has never re-read his own books.' |
| | b Jan zag z'n eigen in de spiegel.
John saw his own \emptyset in the mirror
'John saw himself in the mirror.' |

Alternatively, the reflexive can be expressed with body parts in some fixed expressions.

- (11) Je kunt in die gang je kont niet keren.²
 You can in that corridor your ass not turn
 'One cannot turn oneself in that corridor'

This suggests that the possessive construction *z'n eigen* 'his own' in (10b) contains an empty noun, more specifically an empty body part. It is even possible to trace the gender of this empty noun. The absence of inflection in (12) indicates that the empty noun is a neuter.

- (12) We zagen ons/*onze eigen [ec] in de spiegel
 We saw our[+NEUTER]/our[-NEUTER] in the mirror

It is probably not an accident that the source of the lexical reflexive *self* < SE + *lijf* is a neuter in both Dutch (*het lijf*) and German (*das Leib*).

2.3 Cross-over effects

There is a third argument in favour of the compositional nature of the heavy reflexive: cross-over effects can be observed with simplex focused constituents but not in the case of heavy reflexives.

It is an old observation that focused constituents cannot be coindexed with a c-commanded NP (13b), in contrast to an unstressed NP (13a). The traditional explanation for this fact is that focus is a type of quantification that causes quantifier movement at LF. In this way, the strong ungrammaticality in (13b) reduces to the well-known cross-over effect.

- (13) a ?Dat Ada Oscar_i gezien had wist hij_i niet. Principle C violation
 that Ada Oscar seen had knew he not (weak ungrammaticality)
 'That Ada had seen Oscar, he did not know.'
 b *Dat Ada OSCAR_i gezien had wist hij_i niet. Cross-over effect
 that Ada Oscar seen had knew he not (strong ungrammaticality)
 'That Ada had seen OSCAR, he did not know.'

² The turn *je kont keren* is a negative polarity item. In Dutch, negative polarity is general in constructions with taboo words, in this case *kont* 'ass' (cf. Postma 1996, 1997a).

Significantly, this block on c-command does not hold for heavy reflexives, as illustrated in (14).

- (14) a Oscar zag zichzelf.
 b Oscar zag ZICHZELF. no cross-over effect
 'Oscar saw himself.'

The grammaticality of (14b) is on a par with the absence of cross-over effects in ordinary possessive constructions (15a).

- (15) a Oscar zag ZIJN MOEDER en niet zijn vader.
 'Oscar saw his mother and not his father.'
 b Jan; zei dat ie; ziek was.
 'John said that he was ill.'
 c *Jan; zei dat HIJ; ziek was.
 'John said that he-FOCUS was ill.'
 d Jan zei dat HIJZELF ziek was.
 'John said that he himself was ill.'

The absence of strong cross-over is also observed in other pronominals that are strengthened with *zelf*. Whereas (15c) is ungrammatical,³ (15d) with the reflexive morpheme used as a focus marker is well-formed. These facts follow if the head of the constituent *hijzelf* is not *hij*, as is usually assumed, but *zelf*, i.e. [hij {zelf}]. This structure is provided by the possessive analysis. The analysis suggests that the historical decomposition of *self* as *s+lijf* has synchronic validity.

2.4 Dutch *mijzelf* as *mij* + *s* + *lf*.

It is a property of English that *possessive* pronouns occur in the heavy reflexive: *myself*, *your-self*. Dutch and the other continental Germanic languages utilize the object pronoun: *mijzelf* (i.e. 'me-self'), *jouzelf* ('you-self'), etc. English differs from the latter in an idiosyncratic way. English differs from these languages in yet another feature: the

³ This judgment holds for the spoken language. In the written language, the pronoun *ie* 'he' in (15b) is usually replaced by *hij* 'he'.

existence of double possessive structures such as (16a), where continental Germanic languages such as Dutch use the simple possessive construction (16b).

- (16) a a house of mine/yours. double possessive
 b een boek van mij/jou. ('a book of me/you') simple possessive

According to Kayne (1994), these structures derive from an underlying structure with an 's -possessive, as in (17).

- (17) [CP[a book]_k of [IP your /s/ ...[a book]_k]]

Given Kayne's analysis of the *of*-construction as a surface realization of an underlying regular possessive 's -construction, and given the fact that English has double possessives such as 'of yours', one would expect that English also allows for double possessives in the direct construction. This leads us to analyze English *myself*, vis-a-vis Dutch *mijzelf* ('me-self'), in a similar way as a double possessive, given that /s/ in *self* is a possessive marker both in Dutch and English.

- (18) a your 's lf double possessive
 b jou 's lf single possessive

The parallel between (18) and (16) can only be drawn if the /s/ in *self* is analyzed as a distinct possessive morpheme, not only diachronically but also synchronically. We will not go into the question of what the conditions on double possession may be.⁴

We conclude, however, that there is syntactic evidence from both diachrony and synchrony that reflexives are realized as a possessive construction. The question then arises in what way this result also corresponds to a possessive analysis in the semantic sense.

⁴ Double possessives appear to be possible whenever the possessee is a trace, i.e. a slot which is syntactically present but semantically a dummy. The same condition might hold in the case of a lexical dummy *lf*.

3 Variable formation and implicit quantification

3.1 Zero-semantics and universal quantification

In the previous section, we discussed the Approximation Hypothesis of identity. We hypothesized the existence of dummy bodyparts, which can act as variables. By ranging over these variables, identity comes about.

To treat the phenomenon with sufficient generalization, we will first discuss the idea that the lexical meaning of a word can be deactivated as a function of its syntactic context. The sentence in (1b) contains an example of such a deactivation: although *ra:s* in Arabic has the *lexical* meaning of 'head', this meaning is not present at the propositional level of (1b). Absence of lexical meaning can apparently arise at the propositional level, even if the word is specified for a meaning in the lexicon. We call this phenomenon 'zero-semantics' (ZS).

Zero-semantics (ZS) is not limited to the context of reflexives. We give three examples of zero-semantics in Dutch: loss of lexical meaning (19ab); nonsense-word formation in negative polarity contexts (19c), and the rise of universal quantification under dummy coordination (19de).

- | | | | | |
|------|---|---|---|---|
| (19) | a | Er was geen <i>kip</i> in de stad.
There was no chicken in the town
'There was nobody in town.' | b | Jan doet geen <i>vlieg</i> kwaad.
John does no fly evil
'John does not hurt anybody.' |
| | c | Ik begrijp er geen <i>snars</i> van.
I understand there no SNARS of
'I do not understand anything of it.' | d | Jan heeft <i>kind noch kraai</i> .
John has child nor crow
'John has nobody at all.' |
| | e | Het schip verging met <i>man en muis</i> .
The ship went down with man and mouse
'The ship sank with everyone (on it).' | | |

The words in italics share the property that they do not receive their original, lexical interpretation, which we will call their 'full semantics' (FS). Strictly lexically, (19a) should be true in a situation in which there are a lot of people but no chickens, and false in a situation in which there are no people but some chickens. Nevertheless, there is a reading of (19a) for which Dutch speakers can apply (19a) to the latter situation. In this reading, (19a) is true if there is nobody at all. This indicates that words in zero-semantics are those words that do not contribute a lexical meaning to the semantics *at*

the propositional level. Instead of a lexical meaning, the word receives a quantificational interpretation corresponding to 'nothing', 'nobody'. This suggests that the quantificational reading arises at the cost of lexical meaning. These words can retain their lexical meaning only in a connotative way.

We will consider the case in (19e) in more detail, since it illustrates the emergence of quantification at the cost of lexical meaning most clearly. Constructions like (19e) involve zero-semantics. Moreover, the lexically dummy construction receives a *universal quantificational interpretation*, as is indicated in the translation of (19e). This effect can be stated as in (20):

(20) Dummy coordination gives rise to universal quantification.

Notice first that in the normal case, bare singular count nouns are completely impossible in Dutch as illustrated in (21).

(21) *Het schip verging met man.
'The ship sank with man'

Curiously, the occurrence of bare singular count nouns is not just a possibility in (19e), but a strict requirement. Only then do these nouns exhibit zero-semantics. If plurals are inserted, the effects of zero-semantics disappear: the nouns exhibit their ordinary lexical meaning in 'full semantics'. The sentences (22abc) show that this is true for all cases of ZS illustrated in (19).

- | | | | |
|------|---|-----------------------------------|-------------------------------|
| (22) | a | Er liepen geen kippen in de stad. | (plural; full semantics only) |
| | | There walked no chickens in town | |
| | b | Jan doet geen vliegen kwaad. | (plural; full semantics only) |
| | | John does to no flies evil | |
| | c | Jan heeft kinderen noch kraaien. | (plural; full semantics only) |
| | | John has children nor crows | |

Apparently, plural formation blocks zero-semantics. Why is this the case? What is the interaction of plural formation and the assignment of lexical semantics? An attractive way to look at it is to assume that plural formation is not so much a semantic process but rather a purely morphosyntactic process with interpretative *effects*. The interpretative impact of plural formation is that it protects a lexeme from being

interpreted quantificationally in ZS. Conversely, if we are dealing with bare nouns, these nouns must be interpreted quantificationally in ZS. The *plural* constructions in (22) only give rise to 'full semantics' on the propositional level, which is built up compositionally.

It may be objected that expressions like (19) are idiosyncratic. This is partly true. However, if these effects were to be attributed solely to the lexicalization of the expression, several questions arise immediately. First, why are such bare-singular constructions well-formed at all, and why are these purportedly idiosyncratic expressions *limited* to bare singulars? Moreover, why is this type of quantificational construction productive in the case of duplication within a PP, as is illustrated in (23a)?

- (23) a Ik vroeg het deur aan deur.
 I asked it door to door
 'I asked it at every door.'
- b In de rosse buurt zit raam aan raam een meisje. (wide scope reading)
 in the red-light district sits window to window a girl
 'In the red-light district there is a girl at every window.'
- c In de rosse buurt zit een meisje raam aan raam. (narrow scope reading)
 in the red-light district sits a girl window to window
 'In the red-light district, one and the same girl is sitting at each window.'

In this sentence, a quantificational effect is present (distributive universal quantification) without a word that can be held lexically responsible for it. Hence, attributing these effects exclusively to the lexicon misses the point. Moreover, there is evidence that the constructions are really quantificational: the emerging quantification observes the usual scope effects of quantificational expressions in Dutch (23b-c). In (23b), *raam aan raam* has scope over *een meisje*. In (23c) on the other hand, the existential *een meisje* has scope over the universal quantification construed by *raam aan raam*. This gives rise to a semantically marked reading (a girl would be moving from window to window).

We must conclude that the lexicon cannot exclusively be held responsible for the collective universal quantification present in (19e). If syntax is involved, however, it does not come as a surprise that the coordinative construction is widely attested, cross-linguistically, and within Dutch, as illustrated in (24).

- (24) a Zij waren van *huis en haard* verdreven.
they were from house and stove chased
'they were dispelled from all their possessions/from everything they had.'
- b Zij hebben ons met *man en macht* geholpen.
They have us with man and might helped
'They helped us with everything they had.'
- c Zij hebben zich met *hand en tand* verzet.
They have themselves with hand and tooth resisted
'They resisted with everything (they had).'
- d Ik heb het met *huid en haar* opgegeten.
I have it with skin and hair up-eaten
'I ate it with all parts/ entirely.'
- e Hij klaagde *steen en been*.
He complained stone and bone
'He complained extremely/with all his forces.'
- f * Hij klaagde *steen en steen*.
He complained stone and stone

These constructions represent collective universal quantification. Notice that a coordinative structure with a full duplication of the lexeme, as given in (24f), does not exist. We therefore can make the generalization of (25).

- (25) *Interpretation of coordinative bare singulars*
Let γ be a coordinative construction : [N_1P_{sg} & N_2P_{sg}] with N_1P and N_2P *distinct* bare singulars, then γ is in zero-semantics ([ZS & ZS]), and is interpreted as a *collective* universal quantification ('everyone', 'everything', 'entirely', 'extremely').

A similar generalization can be made for the [NP_1 Prep NP_1] constructions of (23). Consider some additional duplicative constructions in (26).

- (26) a We stonden *bumper aan bumper*,
We stood bumper to bumper
'Our bumpers touched each other / we were standing with our bumpers touching each other.'

- b De kinderen liepen *hand in hand*.
 The children walked hand in hand
 'The children walked with their hands in each other.'

The construction is productive. Remarkably, the $[NP_1 \text{ Prep } NP_1]$ structures in (26) receive a quantificational interpretation as well, in this case a *distributive universal quantification*, which is sometimes realized as a reciprocal interpretation, dependent on the context. Notice that in a sense, the construction in (26) contains a dummy noun as well: one of the nouns is a full copy of the other. The second noun does not contribute an independent lexical meaning to the propositional level and it is hence in zero-semantics. Since [*deur aan deur*] contributes to the propositional level a quantification over doors, the other noun must have full lexical semantics (FS). Let us capture the interpretation of these sentences in the observational generalization (27).

- (27) *Interpretation of duplicated bare singular NP p NP constructions*
 Let δ be a construction $[NP \text{ p } NP]$ with the NPs identical bare singulars and one noun a full copy of the other noun, then δ is interpreted as involving a *distributive universal quantification* with NP as the restrictive set.

It is difficult to see how the co-occurrence of zero-semantics and the rise of quantification in bare singulars can be accounted for by a purely lexical approach. Instead, it seems much more likely that there exist mechanisms of implicit quantification of various sorts. These implicit quantifications operate on open variables, which are present in the syntax. In another context, I have worked out the hypothesis that such open variables are created by nouns lapsing into zero semantics (Postma 1995ab).

3.2 Mechanisms of implicit quantification

As discussed in Postma (1995ab), there are various mechanisms of implicit quantification. In constructions with an open variable, it is the syntactic structure that determines the type of quantification, rather than the lexemes themselves.

A well-known mechanism of implicit quantification that is dependent on the syntactic structure is the one first described in Diesing (1992). Diesing argues that the domain of existential interpretation is VP ('existential closure at VP'). She shows that indefinite constituents are not fixed in their interpretation. Indefinite articles are open

variables to be interpreted. In (28) the indefinite is interpreted as an existential, whereas the same indefinite constituent is interpreted as a generic universal interpretation in (29).

- (28) Er liep een oude man op straat.
 'There walked an old man on the street.'
 ⊢ Er liep een man op straat. within VP; upward entailing;
 'There walked a man on the street.'
- (29) Een man drinkt bier.
 'A man drinks beer.'
 ⊢ Een oude man drinkt bier. outside VP; downward entailing
 'An old man drinks beer.'

Existential quantification allows for upward entailment in the restrictive set, as is illustrated in (28).⁶ In (29), on the other hand, we have a context that is downward entailing in the restrictive set, just like canonical universal quantifiers, like *every*. We can therefore hold the VP-boundary responsible for the entailment properties of indefinites. Upward entailment takes place within VP, downward entailment outside VP.⁷

In these cases, it is the syntactic structure outside the underspecified NP that determines the nature of the quantification. If NPs have more internal syntactic structure, however, the internal make up of the NP itself defines the nature of the implicit quantification. We have discussed these cases briefly in section 3.1. For both mechanisms, it is the case that quantification is described in terms of entailments. The type of entailment (downward/upward) is tied to the syntactic structure.

⁵ When moved from VP to COMP under focus, indefinites retain their existential reading, as in the next answer.

- (i) Q: Wie liep er op het plein?
 A: Een oude man liep op het plein.

I thank Fenneke Van Dijk for bringing this to my attention.

⁶ The symbol ⊢ will be used to indicate entailment between two sentences in the examples, and the absence of formal entailments between sentences will be indicated by *⊢.

⁷ Existential closure at VP is not an isolated phenomenon. Similar effects can be observed with *Wh*-words which behave like open variables as well (Postma 1994).

3.3 Application to reflexive constructions

If reflexives are possessive constructions, the problem arises as to how an individual can be represented by its parts or one of its parts. One way to conceive of this is that an individual can be represented by an implicit universal quantification over his parts, i.e. as in (30a).

- (30) a you saw yourself = $\{\forall X \text{ X is a body part}\}$, you saw [your X]
 b you saw yourself = $\{\exists X \text{ X is a body part}\}$, you saw [your X]

Strictly speaking, this is an incorrect representation of facts, as it would mean that one must be able to see for instance one's back or buttocks in order to see oneself. Universal quantification over all parts is clearly too strong a requirement. This might be simply dismissed as a pragmatic effect: the universal quantification simply ranges over all 'relevant' parts. The problem is that some module of grammar should give content to the notion 'relevant part'. Probably, it must mean something close to 'identifying part'. Only those parts identifying the whole count. However, this line of reasoning relegates the essence of our problem to this pragmatic module without solving it.

Moreover, whereas universal quantification over relevant parts is conceivable in the case of *John saw himself*, the universal quantification approach is completely artificial in the case of *John hurt himself*. In the latter case, one does not want to say that John was wounded in all his (relevant) parts. The problem results from a deeper defect of a summation approach: it takes as a starting point the incorrect assumption that the whole equals the unstructured sum of the parts. This may be true for sets and groups; it is certainly inadequate for inalienable parts of experiencer arguments.

The other option is that the open variable is bound by implicit existential quantification as represented in (30b). If so, *John hurt himself* would mean that John hurt something of himself. Whereas this is close to the truth in the case of *hurt*, it is incorrect in the case of *John knows himself*. John knows a part of himself does not mean the same as John knows himself. In general, existential quantification by itself is clearly too weak a requirement. As we see, the nature of the quantification depends on properties of the construction as a whole.

4 The mechanism of approximation: entailment

Instead of defining the relation between an individual and his parts in terms of summation or existence, we can, alternatively, state this relation in terms of *entailment*. The question is then how a predication over a part of α , can imply a predicate over α as a whole *by entailment*. Put differently: what is the mechanism of the pars-pro-toto effect? In this section, we will see that the mechanism of entailing from possessum to possessee has relevance for the interpretation of reflexives.

4.1 Pars-pro-toto and upward entailment

Let us first show that specific contexts allow entailments from predications over a possessum to a predication over a possessor. Compare the two contexts in (31a) and (31b).

- | | | | |
|------|-----|--------------------------------------|---------------------------------|
| (31) | · a | De monnik had zijn vinger bezeerd. | 'the monk had hurt his finger.' |
| | | ┆ de monnik had zijn hand bezeerd. | 'the monk had hurt his hand.' |
| | | ┆ De monnik had zich bezeerd. | 'the monk had hurt himself.' |
| | b | De monnik had zijn vinger verloren. | 'the monk had lost his finger.' |
| | | *┆ De monnik had zijn hand verloren. | 'the monk had lost his hand.' |
| | | *┆ De monnik had zichzelf verloren. | 'the monk had lost himself.' |

In (31a) the context allows for entailment from the possessum upward to the possessor. We therefore say, in close analogy to the analysis of quantifier NPs (Ladusaw 1980, Zwarts 1984, Postma 1995ab), that (31a) represents an '*upward* entailing possessive context'. Upward entailment is not always possible in possessive constructions. A necessary requirement for upward entailment is that there is an inclusion relation between possessor and possessum, as in (32).

- | | | |
|------|---|--|
| (32) | a | The servant damaged the cup's handle. |
| | | ┆ The servant damaged the cup. |
| | b | The servant damaged the cup. |
| | | *┆ The servant damaged the cup's handle. |

Without inclusion, no formal entailments hold at all, neither upward nor downward, as is illustrated in (33):

- (33) a I damaged John's book. b I damaged John.
 *⊢ I damaged John. *⊢ I damaged John's book.

But the presence of an inclusion relation is not a sufficient condition for upward entailment. Only particular predicates allow for it. The verb *paint* for instance does not create an *upward* entailing context in the possessive argument (34a). In a specific (resultative) reading of *paint*, it is even downward entailing (34b). This effect is most clear when a resultative adjective *red* is added.

- (34) a The servant painted the cup's handle red.
 *⊢ The servant painted the cup red.
 b The servant painted the cup red.
 ⊢ The servant painted the cup's handle red.

It must be noticed that, in considering entailments, we only intend to capture a logical distinction between *damage* and *paint* in first approximation. We obviously do not describe their semantics exhaustively. More fine-grained modifications are necessary. Secondly, it must be noted that it is possible to lift any of these entailments, as the non-contradictoriness of (35a) shows. This is entirely analogous to more canonical downward entailments such as (35b).

- (35) a The servant painted the cup, but forgot the cup's handle.
 b The servant painted all the cups, but he forgot this one.

Despite these reservations, we believe that a characterization in terms of entailments captures an essential part of the semantics of part - whole constructions. It will give us a key to how possessive constructions can produce reflexives.

4.2 Entailment and reflexives

First, we will give further evidence that possessive entailment considerations are relevant for the interpretation of lexical reflexives. A very interesting piece of evidence comes from locative reflexives. First, we will examine the now familiar case of possessive upward entailment in (31), and discuss its syntactic structure.

- (36) a Marie bezeerde d'r voet/zich aan een spijker.
 Mary BE-hurt her foot/SELF DAT a spike
 'Mary hurt her foot/herself on a spike.'
- b Marie be- [aan een spijker zeer- REFL]
 Mary CAUS {DAT a spike hurt herself}

As we have seen (cf. 31), the context of (36a) is upward entailing: if Mary has hurt her foot, she has hurt herself. As we claim, reflexives are underlyingly possessives with a dummy body part. Hence, the semantics of the reflexive counterpart (36b) can be produced by upward entailment from the dummy body part to the whole, i.e. $F(x's BP) \rightarrow F(x)$.

Consider first the syntactic structure of (36a), represented in (36b). The structure is causative. It is identical to a so-called *faire-à* construction. This type of analytic causative constructions has been studied in detail for French (Kayne 1975) and Italian (Burzio 1986). *Faire-à* constructions are causative constructions in which the complement predicate has undergone dative shift (also called *ergativisation*, Den Dikken 1992:235ff). This type of causatives occur, with a more limited distribution in Dutch: in *laten*-constructions, e.g. *laten zien* + Dative, lit. 'let see' ('show'). Apart from the analytic form (causative verb + dative shifted secondary predication), *faire à* constructions also exist in synthetic form, with causative *be-* morpheme as we observe in (36b).⁸ Syntactically speaking, the occurrence of the weak reflexive *zich* must be due to the fact that the reflexive stands in a context of long-distance binding, which allow for weak reflexives only (Everaert 1986). Semantically speaking, the weak reflexive can be used since the construction is upward entailing (cf. 31).

Evidence for the relevance of entailment for the proper use of reflexives comes from a construction with an analogous structure. This construction is structurally identical to the locative construction in (37).

- (37) a Marie zette de tas voor haar voeten neer.
 Mary put the bag in-front-of her feet down
 'Mary put the bag down in front of her feet.'
- b Marie zette de tas voor zich neer.
 Mary put the bag in-front-of REFL down
 'Mary put the bag down in front of her.'

⁸ For the causative nature of *be-*, see Mulder (1992).

Once again, this construction features both long-distance binding and the weak reflexive, and in addition it is upward entailing, since (37a) entails (37b). This confirms the standard case. Look now at a case where this entailment is more intricate.

- (38) a Marie zette de tas naast haar rechtervoet neer.
 Mary put the bag next-to her right feet down
 b Marie zette de tas naast zich neer.
 Mary put the bag next-to REFL down

In principle, we might expect the sentence in (38a) to be true in one of the cases in figure (39): the bag can stand at location *x* (the right side of the right leg) or at location *y* (the left side of the right leg).

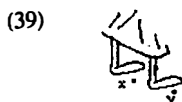

Significantly, the meaning that the bag is at location *x* is highly artificial if not absent in (38a). The reason for its artificiality is that *x* is 'next' to the right foot but is not 'next' with respect to the person as a whole. Apparently, natural language selects such a meaning of *next* in (38a) which allows for upward entailing. Hence, *next to x's body part* is upward entailing in natural language.⁹ Because natural language only assigns one meaning to *next*, it assigns meaning to the reflexive in (38b) by entailment. Humans can infer from [*x*'s body part] → *x*, that is, one creates identity by approximation. The absence of one reading in (38a) is directly predicted by the entailment approach.¹⁰

If, on the other hand, natural language does not allow for upward entailment in a specific syntactic context, the reflexive is ruled out. This can be observed in (40). The preposition *op* 'on' does not have the entailment property: 'on one's foot' does not entail 'on oneself'.

⁹ This means: in the case of inalienable possession.

¹⁰ Similarly, *Mary put a dot next to her eye* has only one reading: the dot must be at the outer side of one of her eyes, rather than between the eyes. I owe this example to Johan Rooryck.

- (40) a Marie zette het hoedje op haar rechtersvoet.
 'Mary put the hat on her right foot.'
 * \vdash Marie zette het hoedje op zich
 'Mary put the hat on REFL.'
- b * Marie zette het hoedje op zich.
 'Mary put the hat on REFL.'
- c Marie zette het hoedje op.
 'Mary put the hat on.'

Significantly, not the *entailment* in (40a) is ruled out, but the very *use* of the reflexive itself is. The reason is that the structure in (40b) cannot receive an interpretation, because upward entailment is not available. Weak reflexives can only be inserted in upward entailing contexts.

As a mirror image, if *op* 'on' does allow for upward entailment, as is the case in *its metaphorical use*, the weak reflexive is fine, cf. (41).

- (41) Jan nam de verantwoordelijkheid op zijn schouders.
 \vdash Jan nam de verantwoordelijkheid op zich.
 'John took the responsibility on his shoulders/on himself.'

This confirms the intimate relation between the use of reflexives and entailment properties.

4.3 Weak and strong reflexives

The entailment approach to possession enables us to make a generalization that will be of use later. Notice first that the type of construction in (42a) is not just a construction of the bodypart type, but these possessives express *inalienable* possession, i.e. they occur in predicates that are obligatorily reflexive. In fact, the subject does not represent the thematic subject, but rather an experiencer. Example (42a) has a reading in which *John* does not count as the agent of *break* but as the experiencer. This reading comes about by a specific syntactic structure, which resists syntactic transformations such as passive formation. *His leg was broken by John* only has the agentive reading. A possible syntactic structure for (42a) is given in (42b). In (42b), there is an inalienable secondary predication in the complement of the de-thematized matrix verb *break*. The DP *John*, which is part of the complement at D-structure, moves to the structural

subject position. This type of secondary predication is poorly understood, but it must be compared with possessor extraction in Hungarian (Szabolcsi 1981). An overt case of such an inalienable secondary predicate is given in (42c).

- (42) a John broke his leg.
 b - broke [_{FP} John F⁰ his leg].
 └──────────────────┘
 c I kissed [Mary on her lips].

In languages that have an opposition between heavy and weak reflexives, such as standard Dutch, such inalienable constructions are realized with *weak reflexives*, i.e. with *zich* rather than with *zich-zelf* (Everaert 1986), or with a definite article instead of a possessive pronoun (Guéron 1985).¹¹

Significantly, these inalienable predicates create a context of upward entailment. For instance, *bezeren* 'hurt' allows for a weak reflexive in the non-agentive reading, whereas *zien* 'see' does not. Correlating with this difference, the verb *bezeren* is upward entailing (cf. 31, 43), whereas *zien* is not (44).

- (43) a De monnik bezeerde zich. (inalienable reading)
 The monk-EXP hurt₁ REFL
 b De monnik bezeerde zichzelf. (*inalienable reading/OKalienable reading)
 The monk-AG hurt₂ REFL
 'The monk hurt himself.'
- (44) Jan zag zijn voet. *1- Jan zag zichzelf.
 'John saw his leg' 'John saw himself.'

¹¹ The inalienable reading often corresponds with a specific reading of the subject: it is not interpreted as the agent, but rather as the possessor/experiencer. This alternation of readings can also be traced in English. Only the alienable reading enters passive formation.

- (i) a John broke his leg (alienable + inalienable)
 b His leg was broken by John (alienable)

However, this effect in interpretation of the subject is not the core effect as it not always there. E.g. in *zichzelf wassen₁* 'himself wash' (alienable) versus *zich wassen₂* 'self wash' (inalienable), both wash₁ and wash₂ mean 'to wash oneself', but only wash₁ has an alienable reading which allows it to be used with non-reflexive objects, i.e. to 'John washed Peter'.

If reflexivization is realized with a strong reflexive *zich-zelf*, no upward entailment holds, as in (44). Very often, transitive verbs allow for both the weak and the strong reflexive, but the correlations remain: only in the reading which allows for the weak reflexive the predicate is upward entailing.¹² These considerations allow us to express the choice of the reflexive in terms of entailments.

(45) *Observational Generalization*

If the entailment $x \vee [x\text{'s BP}] \rightarrow xVx$ holds for any bodypart BP (e.g. *bezeren* 'hurt'), then a weak reflexive is used.

Put differently, standard Dutch *zich* refer to the possessor as a whole, whereas *zichzelf* refers to the possessor with all his (relevant) parts. The interpretation of the weak reflexive comes about by existential quantification + upward entailment (from parts to whole). The interpretation of the strong reflexive is a consequence of universal quantification over parts (downward entailment). This generalization relates a typically morphosyntactic phenomenon (weak/strong reflexive) to the logical property of entailment. This shows that reflexivization and entailments are closely related.

There is an important logical consequence of (45). In a construction α of the shape $[x \vee x\text{'s BP}_1]$, one can distinguish between the meaning of the sentence and its entailment $x \vee x$, as the reading $[x \vee x\text{'s BP}_1]$ is in paradigmatic opposition with any other construction β : $[x \vee x\text{'s BP}_2]$. Although α and β share a semantic component (the entailment $[xVx]$) they are mutually distinct. However, if we insert for BP a dummy body-part or an empty one, the sole traceable semantic component is $[x \vee x]$. In other words, we produce a reflexive construction *by entailment*. We will return to the syntactic possibility and necessity of these logical entailment strategies after gaining a better understanding of the syntax of entailment.

¹² A typical example is *wassen* 'wash', which, next to its inalienable use with a weak reflexive allows for constructions such as (i).

- (i) De patient mocht zichzelf wassen.
'The patient could wash himself'

In this use, the construction has a totality reading 'entirely/all his (relevant) parts', and is, consequently, downward entailing.

4.4 Entailment and syntactic configuration

It would be a mistake to think that the upward entailment in a particular inalienable possession construction is a property of a lexeme, be it the body part or the verb: it is a property of the *configuration as a whole*. There are two considerations that may clarify this point.

In the first place, entailment is tied to what has been called Total Affectedness (TA-ness). Upward entailment in an argument domain only holds true if the argument is not TA. TA contexts are typically downward entailing. This can most clearly be seen from the locative alternation discussed in Mulder (1992), as given in (46). The TA-variant in (46a) does not allow for upward entailment in the affected object. Its locative variant (46b), on the other hand, allows for upward entailment.

- (46) a Jan beplakte *de helft van de muur* met foto's.
 John be-stuck half of the wall with pictures.
 * \vdash Jan beplakte *de muur* met foto's.
 John be-stuck the wall with pictures.
- b Jan plakte foto's op *de helft van de muur*.
 'John stuck pictures on the half of the wall.'
 \vdash Jan plakte foto's op *de muur*.
 'John stuck pictures on the wall.'

In fact, the TA-context in (46b) is downward entailing, as can be seen from (47a). As a mirror image, downward entailment is not allowed in the locative variant (47b).

- (47) a Jan beplakte *de muur* met foto's.
 John be-stuck the wall with pictures.
 \vdash Jan beplakte *de helft van de muur* met foto's.
 John be-stuck half of the wall with pictures.
- b Jan plakte foto's op *de muur*.
 'John stuck pictures on the wall.'
 * \vdash Jan plakte foto's op *de helft van de muur*.
 'John stuck pictures on half of the wall.'

The relation with Aspect ('totally affected') does not come as a surprise, since the crucial semantic component of TA-ness is a universal quantification over parts. A

universal quantification establishes downward entailment in the restrictive set of the object-argument.¹³ We conclude from the data in (46-47) that the aspectual *structure* is relevant rather than the lexemes involved.

An analogous effect can be observed in possessive constructions. The constructions show, once again, that upward entailment in possessive construction depends neither on the verb, nor on the object, but rather on the syntactic *structure*. The observation is that an alienation effect can be observed in the canonical possessive construction (48). The alienation is absent in the dative possessive (49).

- | | | |
|------|--|--|
| (48) | Ik heb Marie's lippen gekust.
'I have kissed Mary's lips.' | *⊢ Ik heb Marie gekust.
'I have kissed Mary.' |
| (49) | Ik heb Marie op de lippen gekust.
'I have kissed Mary on the lips.' | ⊢ Ik heb Marie gekust
'I have kissed Mary.' |

Whereas it is not unusual that lips are involved in the act of kissing, to express the object explicitly in a possessive construction, as in (48a), is unusual and causes alienation: (48a) expresses that 'I' only kissed the lips, not the person Mary. This makes (48a) a semantically deviant construction. In terms of entailment, one may say that (48a) is not upward entailing, i.e. (48b) does not follow from (48a). By contrast, (48a) has a totally affected reading, in that the kissing involved every part of the lips (without involving the person). Hence, (48a) is downward entailing. If we look at the prepositional construction in (49a), the alienation effect is absent. The construction has an, in this case felicitous, inalienable reading: the lips are considered an essential part of Mary. Put differently, the context upwardly entails (49b).

The effects in (46-47) and (48-49) are related. It is not difficult to find a paraphrase of (48) in terms of an overt TA-verb: *bedekken met* 'cover with'.

- | | |
|------|---|
| (50) | Jan bedekte Marie's lippen met kussen.
'John covered Mary's lips with kisses.' |
|------|---|

The alternation in (48-49) must be considered an inalienable possessive variant of the locative alternation in (46).

¹³ We assume that the quantified object scrambles out of the predicate and thus establishes the canonic bipartite structure, in terms of the restrictive set and nuclear scope.

4.5 The syntactic trigger of entailment properties

What is the determining factor of the distinct entailment properties in (48) and (49)? It cannot be pragmatic/semantic or stem from knowledge of the world. Furthermore, the determining factor is not the lexemes, nor the verb, nor the complement noun. It therefore must be the overall syntactic structure. The nature of the structural trigger can be understood in the light of the findings of Diesing (1992). As we have discussed in section 3.2, the interpretation of indefinites is tied to their position with respect to the VP-domain: within VP the existential reading is induced. This means that the VP-domain induces upward entailment in constituents.

If we now look back to the constructions under scrutiny (46-49), we see that in the locative alternation an argument is either realized as a definite direct object (46a, 48), or as a prepositional phrase in the locative variant (46b, 49). As PPs remain within the predicative domain, Diesing's theory predicts that the possessive PPs will be upward entailing. If the same argument is realized as a definite object, however, it obligatorily scrambles out of VP and we expect loss of upward entailment. As we have seen, these predictions are correct. The position of a possessive with respect to the VP domain defines the entailment properties. We conclude that general interpretive principles are responsible for the entailment properties in possessive constructions.

Let us now return to the generalization formulated in (45). This generalization states that upward entailment in an anaphoric possessive construction is syntactically related to the use of weak reflexives. In other words, the (weak reflexive) object may not scramble out of VP for Case at SS/LF. Compare the constructions given in (51).

- (51) a Jan bezeerde zijn vinger.
 'John hurt his finger.'
 b Jan bezeerde zich.
 Jan bezeerde [zich 's \emptyset] with \emptyset an empty possessum
 'John hurt himself.'

As we know, such contexts are upward entailing, i.e. *zijn vinger* must remain in VP and cannot receive Case in SpecAGRP. In order to be licensed, it can only be licensed under incorporation into the predicate. This is called complex predicate formation.¹⁴ We therefore assume that the possessive DP incorporates into the verb at LF (Kayne

¹⁴ This is also called 'tense-linking' of inalienable possessives (Guéron 1985).

1975, Burzio 1986). In a similar vein, the zero possessum in (51b) must be licensed under incorporation into the verb. In both cases, movement out of VP gives rise to loss of the inalienable reading, i.e. to loss of the upward entailing property of the construction.

If a reflexive is a true argument, on the other hand, it moves out of VP in order to receive Case. Such arguments are realized as heavy reflexives in languages with a difference between heavy and weak reflexives. The (heavy) reflexive then resides in the IP-domain. This is the domain where universal quantification is possible, as we have seen in section 3.2. These are the alienable possessive constructions.

This view explains the distinction between *zich* and *zichzelf* in Dutch and their entailment properties. The zero possessum in *zich- \emptyset* must incorporate into the verb: the construction can only be interpreted by upward entailment. The structure determines this interpretation, but is made visible by lexical means in standard Dutch. In those languages that do not have an empty possessum, like substandard Dutch and English, the same structural configuration must be held responsible for the interpretation. In the case of upward entailment the dummy possessum SELF incorporates into the verb. In the other case, the NP is a true argument and receives interpretation outside VP under universal quantification over the parts.

5 Conclusion

We have proposed a possessive analysis of reflexive pronouns (cf. also Postma (forthcoming)). The only binding principle is Principle B, which blocks local binding. In reflexive predicates, possession is used as a syntactic way to circumvent Principle B. Anaphors are not atomic building blocks of language, but have internal syntactic structure. In this way, anaphora is a property of syntactic structure, rather than a property of a lexeme.

In order to neutralize the semantic effect of the possessive construction, approximation strategies are followed. There are two options. The first strategy is universal quantification over parts of α , which amounts up to cover α . The second strategy is upward entailment: a configuration is created that allows for inferences from a predication over a part of α to a predication over α .

These two strategies are made overt in those languages that distinguish heavy and weak reflexives. Heavy reflexives are true arguments, and move out of VP into the IP-domain where the open variable body part is bound by universal quantification ('strong

quantifier'). Weak reflexives are pseudo-arguments and are licensed under incorporation or complex-predicate formation. These stay in the domain of existential closure, VP, i.e. the domain where upward entailments are allowed. Upward entailment creates reflexivity out of a restrictive possessive construction by inference, i.e. inferring from possessum to possessor as a whole. This creates predicative identity without requiring all subparts to be involved in the predication.

References

- Burzio, Luigi. 1986. *Italian Syntax*. Dordrecht: Kluwer.
- Den Dikken, Marcel. 1992. *Particles*. HIL dissertation. Leiden University. The Hague: Holland Academic Graphics.
- Diesing, Molly. 1992. *Indefinites*. Cambridge Mass: The MIT Press.
- Everaert, Martin. 1986. *The syntax of reflexivization*. Doctoral dissertation. Utrecht University.
- Green, John N. 1988. Romance creoles. In: Martin Harris & Nigel Vincent (eds) *The Romance Languages* London: Routledge. 420-473.
- Guéron, Jacqueline. 1985. Inalienable possession, PRO-Inclusion and lexical chains. In: Jacqueline Guéron, Hans-Georg Obenauer & Jean-Yves Pollock (eds) *Grammatical representation*. Dordrecht: Foris.
- Kayne, Richard. 1975. *French Syntax: The transformational cycle*. Cambridge: The MIT Press.
- Kayne, Richard. 1994. *The Antisymmetry of Syntax*. Cambridge: The MIT Press.
- Ladusaw, William. 1980. *Polarity sensitivity as inherent scope relations*. Ph.D. dissertation, University of Texas.
- Lettinga, Jan Pieter. 1992. *Grammatica van het Bijbels Hebreeuws*. Leiden: Brill.
- Marácz, László K. 1989. *Asymmetries in Hungarian*. Doctoral dissertation. University of Groningen.
- Mulder, René. 1992. *The aspectual nature of syntactic complementation*. HIL dissertation. Leiden University. The Hague: Holland Academic Graphics.
- Pica, Pierre. 1988. Sur le caractère inaliénable de l'être. In: Tibor Papp & Pierre Pica, (eds) *Transparence et opacité*. Paris: Éditions du Cerf.
- Postma, Gertjan. 1993. The Syntax of the morphological defectivity of BE. *HIL manuscripts* 3. 31-67.
- Postma, Gertjan. 1995a. Zero-semantics - the syntactic encoding of quantificational meaning. In: *Linguistics in the Netherlands 1995*. Amsterdam: Benjamins, 175-190.
- Postma, Gertjan. 1995b. *Zero semantics. a study of the syntactic conception of quantificational meaning*. HIL dissertation. Leiden University. The Hague: Holland Academic Graphics.
- Postma, Gertjan. 1996. *Negative voiding and the interpretive nature of negation*, talk presented at the Taalkundig Colloquium, Groningen.
- Postma, Gertjan. 1997a. Negative polarity and the syntax of taboo. In: Jack Hoeksema et al. (eds) *Perspectives on Negation*. Amsterdam: Benjamins.

- Postma, Gertjan. 1997b. On the syntactic nature of possession. *Lingua* 101. 271-294.
- Postma, Gertjan. (forthcoming). *Zero-semantics as the source of anaphora: the heavy reflexive SELF*. Ms. Leiden University.
- Reinhart, Tanya & Eric Reuland. 1991. Anaphors and logophors: an argument structure perspective. In: Jan Koster & Eric Reuland (eds) *Long-distance anaphora* Cambridge: Cambridge University Press.
- Renan, Ernest. 1990. [1858]. De l'origine des langues. Appendix to: Jean-Jacques Rousseau - *Essai sur l'origine des langues*. Paris: Agora.
- Rosen, Carol. 1990. Rethinking Southern Tiwa. *Language* 66. 669-713.
- Szabolcsi, Anna. 1981. The possessive construction in Hungarian: a configurational category in a non-configurational language. *Acta Linguistica Academiae Scientiarum Hungaricae*, 31.
- Zwarts, Frans. 1986. *Categoriale grammatica en algebraïsche semantiek : een onderzoek naar negatie en polariteit in het Nederlands*. Doctoral dissertation. Groningen University.

Long Distance 'Binding' in Icelandic: Syntax or Discourse?

Eric Reuland and Sigríður Sigurjónsdóttir

1 Introduction*

The anaphor *sig* in Icelandic has generated considerable interest in linguistic theory ever since it was first discussed in the generative literature by Thráinsson (1976). As outlined in Thráinsson (1976)¹, *sig* in Icelandic may take a long distance antecedent when the clause that contains *sig* is infinitive or subjunctive (i.e. the antecedent may be beyond the nearest c-commanding subject). However, if *sig* is contained in an indicative clause, it can only refer to the local antecedent. This is exemplified in (1).²

* The authors would like to express their gratitude to Martin Everaert for his extensive and important comments on previous versions of this article. Eric Reuland also wishes to thank NIAS, and especially the SynCom theme group, for providing a very stimulating environment allowing him to complete this article.

¹ See also, Thráinsson (1979, 1990, 1991), Maling (1984, 1986), Anderson (1986), Rögnvaldsson (1986), Sells (1987), Sigurðsson (1990), Sigurjónsdóttir (1992), among others.

² We abstract away from the two different verb classes which have different effects on the interpretation of *sig*. With one class of verbs, like the verb *raka* 'shave' exemplified in (1), *sig* can take either a local or a long distance antecedent in the infinitive and subjunctive domain, whereas with the other class of verbs, *sig* can only refer to the long distance antecedent. We will not discuss these facts further since the class of verbs only affects the interpretation of *sig* in the local domain which is not the domain that concerns us here. These lexical effects in Icelandic (first noted by Thráinsson) are described by Hyams and Sigurjónsdóttir (1990), Sigurjónsdóttir (1992), and Sigurjónsdóttir and Hyams (1992). Similar lexical effects have been discussed by Everaert (1986) and Reinhart and Reuland (1989, 1991, 1993) for Dutch and by Hellan (1988) for Norwegian.

- (1) a Jón_j skipaði Pétur_i [að PRO_i raka_(infinitive) sig_{(i, j), *k} á hverjum degi].
 John ordered Peter to shave SIG every day
- b Jón_j segir [að Pétur_i raki_(subjunctive) sig_{(i, j), *k} á hverjum degi].
 John says that Peter shaves SIG every day
- c Jón_j veit [að Pétur_i rakar_(indicative) sig_{(i, *j), *k} á hverjum degi].
 John knows that Peter shaves SIG every day

Various proposals have been developed in the literature to account for the long distance use of *sig* in sentences like (1a) and (1b). These proposals can be divided into two groups according to their approach to the long distance subjunctive case. One group of approaches assumes a unified syntactic analysis of long distance *sig* in subjunctives and infinitives. One such analysis is Anderson's (1986) 'Tense-Agreement' account of Icelandic anaphora. Anderson postulates an 'anaphoric domain' in which *sig* has to be bound by a 'superordinate subject'.³ Infinitive complements always constitute an anaphoric domain whereas in subjunctives an anaphoric domain is established when a rule of 'Tense-Agreement' which copies the tense of the matrix clause onto the subjunctive complement has applied. It follows that *sig* can take a long distance antecedent out of infinitives and subjunctives, given that an anaphoric domain has been established in subjunctives. Thus, the same account, stated in terms of an anaphoric domain, is given for long distance *sig* in infinitives and subjunctives.⁴ Furthermore, both the Parameterized Binding Theory, developed in Wexler and Manzini (1987),⁵ and the movement analysis of anaphors, proposed in Pica (1985, 1987),⁶ treat long distance *sig* in subjunctives and infinitives in a parallel fashion. Within Wexler and Manzini's (1987) Parameterized Binding Theory, the

³ Anderson (1986:76) gives the following definition of an anaphoric domain: "The ANAPHORIC DOMAIN of A is the minimal S or NP containing A, a governor of A, and a subject of either tensed S or NP which c-commands A."

⁴ Note that Anderson's proposal accounts for the fact that in embedded infinitives in Icelandic, *sig*, but (normally) not the pronouns, can take the matrix subject as its antecedent, whereas both *sig* and the pronouns can refer to the matrix subject in subjunctives. The obligatoriness of *sig* in this domain in infinitives follows from Anderson's analysis since an infinitive and its matrix clause always constitute an anaphoric domain. The rule of Tense-Agreement, on the other hand, optionally applies to the subjunctive clause, and hence either an anaphoric domain is established and *sig* refers to the matrix subject or there is no anaphoric domain in which case a pronoun is used to refer to the long distance antecedent. An alternative analysis for these facts is proposed in Sigurjónsdóttir (1992).

⁵ See also Manzini and Wexler (1987), Johnson (1984), Koster (1984), and Yang (1984).

⁶ See also Lebeaux (1983, 1985) and Chomsky (1986).

governing category for *sig* is determined by [+indicative mood], and thus the antecedent possibilities for *sig* should be the same out of infinitives and subjunctives. Similarly, Pica (1987) proposes that *sig* undergoes head movement out of infinitives and subjunctives at the level of Logical Form, again predicting parallel antecedent possibilities on the two conditions.

The other approach to long distance anaphora in Icelandic maintains that the long distance use of *sig* out of subjunctives is ruled by discourse factors rather than syntactic principles. Thráinsson (1976, 1990, 1991), Maling (1984), Sells (1987), Sigurðsson (1990), and Sigurjónsdóttir (1992) observe that the antecedent possibilities of long distance *sig* in subjunctives are not constrained by structural conditions such as c-command but rather by discourse factors such as perspective or point of view. Also, as pointed out by Thráinsson (1976, 1990), the presence of a subjunctive complement is not enough to license long distance use of *sig*. Thus, only a certain type of subjunctives allow *sig* to take a long distance antecedent, in particular, subjunctives which imply "...a report from the higher subject's 'point of view'." (Thráinsson, 1976:229). Subjunctives which state a fact about the matrix subject and do not convey the higher subject's perspective or point of view, on the other hand, do not allow *sig* to be coindexed with the matrix subject. Thus, the long distance use of *sig* is not fully determined by the presence of a subjunctive complement. Rather, it seems as if discourse information can only be accessed if there is a subjunctive. If it can, it still has to be of the 'right kind'.

Hagège (1974) and Clements (1975) were the first to relate the use of long distance *sig* in subjunctives to logophoricity. This idea was further pursued in Maling (1984). Characteristic of logophoric pronouns is that they are used in 'reportive contexts' to refer back to an individual (other than the speaker-narrator) whose speech, thought, feeling, or point of view is reported on in the sentence (from Maling (1984:211, 231)). As discussed most extensively by Sigurðsson (1990), this more or less sums up the semantic properties of *sig* when it takes a long distance antecedent out of subjunctives.

These two approaches to long-distance anaphora in Icelandic make different predictions regarding the antecedent possibilities of *sig*. According to the first approach, long distance *sig* should be subject to the same constraints in subjunctive and infinitive clauses, i.e. structural conditions such as c-command and discourse factors such as perspective or point of view should play the same role in both domains (for many authors no role, as far as discourse factors are concerned). The second approach, on the other hand, predicts that long distance *sig* in subjunctives and infinitives is governed by different factors. Whereas discourse factors should be

relevant for the logophor *sig* in subjunctives, such factors should not play a role in the infinitive case where the interpretation of *sig* should only be constrained by structural principles.

Note that, if such a difference between infinitival and subjunctive domains can indeed be observed, this would not by itself exclude the possibility that strictly grammatical factors play a role. For instance, it could be that some grammatical factor associated with subjunctives, but not with infinitives, entails that logophoric interpretation is in principle admissible, whereas discourse factors determine whether the ensuing interpretation is wellformed. We will return to this possibility near the end of this article. For the time being we will restrict discussion to the two approaches in general.

In this article, then, we will argue that the Icelandic data provides support for the second approach, that is, we will argue that there are consistent differences between the antecedent possibilities of *sig* in subjunctives vs. infinitives. In the literature the focus of research has been the subjunctive domain and how it differs from the indicative. Much less attention has been paid to the infinitive case and until now the different tests for discourse vs. syntactic principles have not been applied systematically to the two domains. This calls for a more detailed analysis of the mechanisms governing *sig* in subjunctives and infinitives, and in this article we will attempt to give the relevant data for each case.

2 Subjunctives

It is by now a well known fact that long distance *sig* in subjunctives in Icelandic can sometimes take as its antecedent a non-c-commanding NP. Thus, as first observed by Maling (1984), the NP *Jón* can serve as the antecedent for *sig* in sentences like (2), although it does not c-command the anaphor.⁷

(2) a $[_{NP} \text{ Skoðun Jóns}]_i \text{ er } [_{að} \text{ sig}]_{i \text{ ACC}} \text{ vanti}_{\text{SUBJ}} \text{ hæfileika}]_j$.

Opinion John's is that SIG lacks talents

'John's opinion is that he lacks talents.'

(cf. Maling, 1984:222)

⁷ Note that *sig* in Icelandic does not have a nominative form (see Everaert, 1990, for a discussion of this fact). Hence, *sig* can occur in subject position only with those verbs that select a non-nominative subject, i.e. with the so-called 'quirky' case verbs in Icelandic. The verb *vanta* 'to lack, need' which appears in example (2a) is one of these verbs and takes an accusative subject. Quirky subjects in Icelandic have been discussed by a number of authors, see, for example, Andrews (1976), Thráinsson (1979), Bernóðsson (1982), Zaenen, Maling, and Thráinsson (1985), and Sigurðsson (1989, 1992).

- b [_{NP} Álit Jóns]_j virðist [_{t_i} vera [að ég hati_{SUBJ} sig]_j].
 Belief John's seems be that I hate SIG
 'John's belief seems to be that I hate him (=John).'
- c Björn sagði Pétri frá [_{NP} ósk Jóns]_i um [að Ari sýndi_{SUBJ} sér_i virðingu].⁸
 Björn told Peter about wish John's about that Ari showed SIG respect
 'Björn told Peter about John's wish that Ari showed him (=John) respect.'

Furthermore, *sig* in subjunctives can sometimes refer to a non-c-commanding matrix object, as illustrated in (3).

- (3) ?Jón_i er masókisti. Það gleður Jón_i [að ég muni_{SUBJ} lemja sig_i í hausinn með spýtu á morgun].
 'John is a masochist. It pleases John that I will hit SIG in the head with a stick tomorrow.'
 (cf. Sigurjónsdóttir, 1992:95)⁹

These sentences show that the antecedent possibilities of *sig* in the long distance subjunctive case are not constrained by a c-command requirement. By comparing these sentences to the ones in (4), we see that the antecedent-anaphor relations, on the other hand, are discourse dependent in the sense that the antecedent of *sig* has to play a particular role in the discourse. More specifically, it must be the person (distinct from the speaker-narrator) whose perspective or point of view is reported in the sentence.

- (4) a * [_{NP} Skoðun Jóns]_j fær mig til að halda [að sig_i ACC vanti_{SUBJ} hæfileika].
 Opinion John's leads me to to believe that SIG lacks talents
 'John's opinion leads me to believe that he lacks talent.'
 (cf. Maling, 1984:222)
- b * [_{NP} Vinur Jóns]_j telur [að ég hati_{SUBJ} sig_i].
 Friend John's believes that I hate SIG
 'John's friend believes that I hate him (=John).'

⁸ Note, that there are two NPs in this sentence whose perspective or point of view are being reported, i.e. *Jón* and *Björn*. Hence, *sig* could also take *Björn* as its antecedent.

⁹ Note that objects are generally not the perspective holding NP of a sentence, and hence, they rarely qualify as antecedents for the logophor *sig* (see Sigurðsson, 1990:334).

- c *Petta vandamál, krafðist þess [að við hugsuðum_{SUBJ} stöðugt um sig].
 This problem demanded it that we thought constantly about SIG
 'This problem demanded that we constantly think about it.'
 (cf. Sigurðsson, 1990:335)

In the ill-formed sentences in (4), the coindexed NP bears the same structural relation to *sig* as in the well-formed sentences in (2). The difference between these two sets of sentences is that in (2), *Jón* is the person (distinct from the speaker) whose opinion, belief, or wish is reported in the sentences. In (4a,b), on the other hand, the sentences are not reported from *Jón*'s point of view; rather it is the 1st person pronoun 'me' in (4a) and the NP 'John's friend' in (4b) which carry the perspective of these sentences. This analysis is further supported by the example in (4c), which shows that an inanimate NP, which cannot possibly be a perspective holder, cannot serve as the antecedent for *sig* in subjunctives.

Furthermore, it has been noted in the literature (Maling, 1984:232; Sigurðsson, 1990:336) that passives in Icelandic do not in general allow their subjects to serve as antecedents for long distance *sig*. If *sig* in embedded subjunctives is ruled by discourse factors, we expect that the derived subject of a passive should not be able to serve as an antecedent for *sig*, since a derived subject does not usually carry the perspective or point of view of the sentence. This is illustrated in (5).

- (5) a Jón_i sagði Pétri_j [að ég elskaði_{SUBJ} sig_{i,j}]. (active)
 'John told Peter that I loved SIG.'
 b *Pétri_j var sagt (af Jóni_i) [að ég elskaði_{SUBJ} sig_{i,j}]. (passive)
 'Peter was told (by John) that I loved SIG.'

In (5a) *sig* takes the perspective holding subject *Jón* as its antecedent, but in the passive sentence in (5b) where neither *Jón* nor *Pétur* bear the perspective of the sentence, *sig* cannot refer to the c-commanding subject nor to the *by*-phrase.¹⁰

¹⁰ As observed by Sigurðsson (1990, fn. 22), the exceptions to this generalization show that the passive as such does not block long distance coreference with *sig*. Thus, as illustrated in (i), the derived subject of a passive (*honum* 'him' in this case) can serve as an antecedent for *sig* in subjunctives, given that it carries the perspective or point of view of the sentence. As pointed out by Sigurðsson: "made x believe" implies "x believes".

- (i) Honum_{DA} var talin trú um [að sig_{ACC} vantaði_{SUBJ} hæfileika].
 Him was made belief about that SIG lacked talents
 'He was made to believe that he lacked talent.'
 (cf. Maling, 1984, fn.28)

The minimal pair in (6), reported in Sells (1987:451), further strengthens the claim that the antecedent possibilities of *sig* in subjunctives are determined by discourse factors.

- (6) a Barnið, lét ekki í ljós [að það hefði_{SUBJ} verið hugsað vel um sig_i].
 The child put not in light that there had been thought well about SIG
 'The child didn't reveal that she had been taken good care of.'
- b *Barnið, bar þess ekki merki [að það hefði_{SUBJ} verið hugsað vel um sig_i].
 The child bore of it not signs that there had been thought well about SIG
 'The child didn't look as if she had been taken good care of.'

The difference in grammaticality between (6a) and (6b) can be attributed to the fact that in the (a) sentence, the report is made from the child's point of view, i.e. it is the child, and not the speaker, who didn't reveal that he/she had been taken good care of, whereas in the (b) sentence, it is the speaker who reports that the child didn't look as if he/she had been taken good care of. Hence, *sig* in subjunctives demands an antecedent that bears the perspective or point of view of the sentence and whether or not this NP c-commands the anaphor is irrelevant.

3 Infinitives

Turning to *sig* in infinitive clauses, it has been observed in the literature that long-distance *sig* in infinitives can only take a matrix subject and not a matrix object as an antecedent (cf. Thráinsson, 1979, 1991; Sigurjónsdóttir, 1992). This is illustrated in (7).

- (7) a Jón_i skipaði mér_j [að PRO_i lemja_{INF} sig_i].
 'John ordered me to hit SIG.'
- b *Ég_i hótaði Jóni_j [að PRO_i lemja_{INF} sig_i].
 'I threatened John to hit SIG.'

This result, by itself, is neutral. The contrast between (7a) and (7b) could follow from the difference in perspective these sentences show, but it could also follow from the difference in c-command. If *sig* in infinitives must be c-commanded by its antecedent, it follows that *sig* can take the c-commanding subject in (7a) as an antecedent but not the non-c-commanding object in (7b). If the second approach is to be supported, we

should find that only structural conditions such as *c*-command are relevant in this domain and that the interpretation of *sig* is neither independently constrained, nor licensed by discourse factors. Thus, in cases where the *c*-command requirement is not met but the sentence contains a perspective holding NP as a potential antecedent, we predict that *sig* in infinitives will not be able to refer back to this NP. As we see in (8), this prediction is borne out, i.e. *sig* in infinitives cannot take a non-*c*-commanding NP as an antecedent, even if it is a possible perspective holder.

- (8) a *_{[NP Skoðun Jóns]_j} virðist [_{t_j} vera_{a,INF} hættuleg fyrir sig_i].
 Opinion John's seems be dangerous for SIG
 'John's opinion seems to be dangerous for him.'
- b *_{[NP Ósk Jóns]_j} er líkleg til [_{t_j} að hafa_{a,INF} slæmar afleiðingar fyrir sig_i].
 Wish John's is likely to to have bad consequences for SIG
 'John's wish is likely to have bad consequences for him.'
- c *_{[NP Álit Jóns]_j} er sagt [_{t_j} hæfa_{INF} sér_i vel].
 Belief John's is said suit SIG well
 'John's belief is said to suit him well.'

Thus, the sentences in (8) show that for *sig* in infinitival clauses discourse factors are unable to compensate for the lack of *c*-command. This contrasts with the situation in subjunctives discussed earlier, where we saw the antecedent possibilities of *sig* are determined by discourse properties (cf. (2) and (3)). Moreover, if the antecedent of *sig* in infinitives is only constrained by structural conditions, we would predict that the derived subject of a passive should be a possible antecedent for *sig*, since the subject *c*-commands *sig*, even if it is not a perspective holder. This is indeed the case as shown by the examples in (9) and (10).

- (9) a Jón_i sagði [Maríu_j hafa_{INF} látið [mig þvo_{INF} sér_{i,j}]].
 John said Mary have made me wash SIG
 'John said Mary to have made me wash him/her.'
- b María_i var sögð (af Jóni_j) [_{t_j} hafa_{INF} látið [mig þvo_{INF} sér_{j,*i}]].
 Mary was said (by John) have made me wash SIG
 'Mary was said (by John) to have made me wash her (=Mary).'
- (10) a Jón_i sagði [þetta vandamál_k hafa_{INF} neytt okkur_k til [að PRO_k leysa_{INF} sig_j]].
 John said this problem have forced us to to solve SIG
 'John said that this problem forced us to solve it.'

- b Þetta vandamál, var sagt [t_j hafa_{INF} neytt okkur_k til [að PRO_k leysa_{INF} sig_j]].
 This problem was said have forced us to to solve SIG
 'This problem was said to have forced us to solve it.'

As exemplified in (9b) and (10b), *sig* in an infinitive complement can take the subject of a passive sentence as an antecedent (whether it is animate or inanimate), although this subject does not carry the perspective or point of view of the sentence. This shows that c-command, and not discourse factors, determines the antecedent possibilities of *sig* in infinitives.

4 Summary of the facts

We have seen so far, that there are consistent differences between the conditions on long distance antecedents for *sig* in subjunctive and infinitive complement clauses. *Sig* in subjunctives is constrained by discourse factors; in particular, the antecedent of *sig* has to be the person (other than the speaker-narrator) whose perspective or point of view is presented in the sentence, and whether or not this antecedent c-commands *sig* is irrelevant (cf. examples (2)-(6)). The antecedent possibilities of *sig* in infinitives, on the other hand, are uniquely governed by the structural condition of c-command, and discourse factors are not reflected in this domain (cf. examples (8)-(10)). Thus, for example, *sig* in subjunctives cannot refer to an inanimate NP (cf. example (4c)) nor to the derived subject of a passive (cf. example (5b)), since these NPs cannot serve as perspective holders. Inanimate subjects (cf. example (10b)) and the subject of a passive sentence (cf. examples (9b) and (10b)), on the other hand, can serve as antecedents for *sig* in infinitives, since the subject c-commands *sig*. Moreover, *sig* in infinitives cannot take a non-c-commanding matrix object as an antecedent (cf. example (7b)), whereas *sig* in subjunctives can, provided that the object bears the perspective or point of view of the sentence (cf. example (3)). If the mechanisms governing *sig* in subjunctives and infinitives were of same type, as proposed by Anderson (1986), Wexler and Manzini (1987), and Pica (1985, 1987), among others, we would not expect these differences. Non-c-commanding antecedents should then be equally available in infinitives and subjunctives, and non-perspective holding NPs (such as inanimate and passive subjects) should be able to serve as antecedents for *sig* in subjunctives just as in the infinitive case. Hence, we conclude that the Icelandic data is only consistent with analyses (such as the one proposed in Reinhart and

Reuland, 1989, 1991, 1993) which differentiate between the mechanisms governing long distance *sig* in subjunctives and infinitives.

5 Discussion

The facts discussed lead to the question of what is the relation between long distance bound *sig* and its antecedent. Since Reinhart's work on anaphoric relations it has been established that syntactic binding requires c-command (see Reinhart (1983) for detailed discussion of the properties of the c-command relation). It would be conceivable to argue that, in fact, in the subjunctive domain in Icelandic syntactic binding of some sort would nevertheless be involved. The following contrast indicates that such an approach would lack independent support.

As discussed in Thráinsson (1991:60), the strict/sloppy identity ambiguity typically associated with pronouns also shows up with *sig* in the long distance subjunctive case. This can be illustrated as follows:

- (11) Jón_i telur [að próffessorinn muni fella_{SUBj} sig_i á prófinu] og Ari, telur það líka.
'John believes that the professor will fail SIG on the test and Ari believes so too.'
a = Ari believes that the professor will fail Ari on the test
b = Ari believes that the professor will fail John on the test

However, it is impossible to get the sloppy (i.e. bound) reading in cases where subjunctive *sig* is not c-commanded by its long distance antecedent. As demonstrated in (12), we only get the strict (coreference) reading in this case.

- (12) Skoðun Jóns_i er [að sig_i vanti_{SUBj} hæfileika] og það er skoðun Péturs_j líka.
'Opinion John's is that SIG lacks talents and that is opinion Peter's too.'
'John's opinion is that SIG lacks talents and that is Peter's opinion too.'
a ≠ Peter's opinion is that Peter lacks talents
b = Peter's opinion is that John lacks talents

This is evidence, that the relation between *Jón* and *sig* in (12) must be one of coreference, rather than syntactic binding.¹¹

If in subjunctive contexts *sig* and its antecedent may be related, not by binding, but by coreference, this is clearly at variance with the standard view of anaphors based on Bouchard (1984). Reinhart & Reuland (1991) extend the standard view in requiring the underspecified element to obtain its missing φ -features, directly or indirectly, from its antecedent in the syntax by chain formation of some sort.¹² However, it is precisely such a view which fails to account for cases where the anaphor is not c-commanded by its antecedent. It fails in a fundamental way, since the anaphor cannot pick up the necessary φ -features without ending up with the wrong antecedent. In fact, the situation is even worse, from that perspective, since in other cases *sig* may occur, and be interpreted, without any linguistic antecedent whatsoever. This is illustrated in (13):

- (13) *María var alltaf svo andstyggileg. Þegar Ólafur, kæmi_{sl,20} segði hún sér_{1,r}, áreiðanlega að fara ...* (Sigurðsson 1990:317)
 'Mary was always so nasty. When Olaf came, she would certainly tell himself [the person whose thoughts are being presented - not Olaf] to leave.'

¹¹ It should be noted, in this connection, that locally bound *sig* does not allow a strict reading. This is illustrated in (i):

- (i) *Jón, rakaði sig, og Pétur, gerði það líka.*
 'John shaved SIG and Peter did so too.'
 ≠ Peter shaved John

Yet, in the long-distance infinitive case both readings are possible.

- (ii) *Jón, skipaði prófessornum, [að PRO_i fella_{inf} sig_i á prófinu] og Ari gerði það líka.*
 'John ordered the professor to fail SIG on the test and Ari did so too.'
 a = Ari ordered the professor to fail Ari on the test
 b = Ari ordered the professor to fail John on the test

This may indicate that what forces the sloppy reading in (i) is not a property of the antecedent-anaphor relation, but a property of the predicate. In (i) the copied predicate is intrinsically reflexive, whereas (ii) has no reflexive predicate (see Sigurjónsdóttir (1992) for discussion of intrinsic reflexives in Icelandic).

¹² According to Reinhart & Reuland (1991) *sig* is, therefore, covertly moved to I/AgrS. In this position, it is proposed, it not only copies the φ -features from Agr, but also the index that Agr receives by agreement with the subject. Hence the subject orientation of this type of anaphor.

As argued in Reuland (1996), taking such examples seriously forces one to abandon the idea that anaphors must be syntactically bound for reasons of interpretability. This leads to two questions: (i) What principle governs the interpretation of anaphors when they are not syntactically bound? and (ii) Why isn't the option of such an interpretation always available? The answer to the first question has in fact been provided in Ariel (1990). Central in her theory is the notion of *accessibility*, which reflects the discourse prominence of an antecedent. On the basis of an investigation of cross-sentential anaphoric relations in actual texts, Ariel establishes that the degree of lexical specification of an element is inversely related to the accessibility of its discourse antecedent. Full NP's can be used anaphorically; but only felicitously if the discourse antecedent is low on the scale of accessibility. The felicitous use of pronouns requires a discourse antecedent that is more accessible. An expression that is less specified, such as the Icelandic anaphor *sig*, should require a discourse antecedent that is even higher on the scale of accessibility. This is precisely what is reflected in the conditions on the logophoric interpretation of *sig* we discussed. We found structurally equivalent environments, where a felicitous use of *sig* solely depended on the status of its antecedent in the discourse.¹³ Thus, the logophoric use of *sig* realizes an option that Ariel's theory predicts to exist. How, then, should we interpret the fact that Ariel's approach remains silent on the question of why *sig* in other than subjunctive contexts does require a syntactic binder? It seems to us that the situation reflects the interaction, or rather the lack of interaction between the computational and interpretive systems. Both operate blindly. Within sentence grammar, properties of the computational system cut across the patterns of the interpretive system. Whenever there is a choice, using the computational system takes precedence. Only where the computational system has nothing to say can the effects of pragmatic conditions on interpretation be directly observed. An extensive discussion of how binding relations can be captured by the computational system, and to what extent, is given in Reuland (1995, 1996), taking Reinhart & Reuland (1993) as a starting point. For limitations of space, we will not recapitulate the whole discussion. Rather, we will just sketch some of the considerations immediately relevant to our present concerns.

Let us start noting that binding relations essentially belong to the interpretive system (see Chomsky 1995). They have no natural place in the syntactic system,

¹³ Ultimately, an understanding of these phenomena requires a more elaborated theory of discourse prominence than is available at this point. That is, although our results make clear that well-formedness changes with perspective, it is not at all trivial to construct an adequate theory of perspective (see Cornelis (1996) for discussion). We will have to relegate this to future research.

except in so far as the syntax creates the objects to be interpreted, and binding relations may be encoded in these objects. This notion of syntactic encoding can be made precise against the background of the theory of Chomsky (1995): the only operations in the syntax are Checking (with concomitant deletion or erasure of features), Move/Attract, and Merge. The main thesis of Reuland (1995, 1996) is, then, that binding relation may indeed be syntactically encoded, but only as a side effect of the creation of a syntactic object by an independently motivated process.¹⁴ In the case of anaphors like *sig*, it is claimed that the binding relation is syntactically encoded as a chain. A detailed discussion of the mechanism is given in Reuland (1995). Here we will limit ourselves to the general conception. The guiding principle is 'minimize the number of syntactic objects' (i.e. form a chain where possible). The chains encoding binding relations are formed by linking two formal dependencies that exist independently. One reflects the Case relation between the verb and the object (here, *sig*) and the other reflects the agreement between the subject and the verbal inflection. More precisely, we assume that at the relevant level the verb has merged with inflection forming a V/I complex, and that the Case relation between the verb and *sig* is syntactically encoded on that complex. By themselves, these assumptions are not controversial, and they can be straightforwardly implemented in the theory of Chomsky (1995). (Note, though, that much of the specific implementation is not crucial to our approach).¹⁵ The result is illustrated in (14):

(14) DP ... [_{V/I} φ_{AGR} φ_{sig}]... *sig*

Here, the agreement features of the V/I complex are represented by φ_{AGR} , and the Case relation of the verb in the V/I complex with *sig* by the features φ_{sig} . It is also uncontroversial that agreement between subject and verb involves the checking of features. This yields a formal dependency between the subject DP and φ -features inside the V/I complex. The crucial assumption is that for the mechanism effecting agreement φ_{AGR} and φ_{sig} are equally visible. So, among the dependencies that can be formally represented we also find, as a byproduct of the process establishing the dependency $\langle DP, \varphi_{AGR} \rangle$, the dependency $\langle DP, \varphi_{sig} \rangle$. As we saw, $\langle \varphi_{sig}, sig \rangle$

¹⁴ Note, incidentally, that Chomsky (1995) takes the position that binding relations are not encoded in the syntax, but only at the CI interface. For arguments that this position cannot be maintained, see Reuland (1995, 1996).

¹⁵ So, the encoding of the Case relation between the verb and *sig* can be implemented by (covert) movement of the φ features of *sig* (along the lines of Chomsky (1995)), and the merger of V and I by movement of V to I.

is also among the formal dependencies. We will be making the assumption that this dependency relation is transitive; thus, $\langle DP, sig \rangle$ is among the formal dependencies as well, and in fact has the status of a chain (see Reuland (1995, 1996)).¹⁶ This chain is thus a syntactic object encoding the relation between the anaphor and its antecedent.

Clearly, the possibility of forming a chain is restricted. For instance, if the object is lexical NP or a pronoun, instead of *sig*, a chain cannot be formed. What, then, blocks chain formation in those cases? As is argued in Reuland (1995, 1996), the relevant factor is grammatical number: *sig* is not marked for grammatical number, pronouns and lexical NPs are. For lack of space, we will simply stipulate at this point that grammatical number on α in (15) will block checking, and make formation of a chain $\langle DP, \alpha \rangle$ impossible:¹⁷

(15) DP ... [_{VP} φ_{AGR} φ_{α}] ... α

The following question concerns us directly, though: Why doesn't *sig* always end up chained to a subject? If this were the case, the logophoric interpretation would never surface.¹⁸ The logic of the argument dictates that logophoric *sig* can only occur where it is impossible for *sig* to be chained to a subject. So, whatever the precise nature of subjunctive, some of its properties must affect this process.¹⁹ A number of possibilities can be easily eliminated. There is no evidence that either Case assignment to the object, or agreement with the subject are themselves affected by

¹⁶ Chomsky (1995) in fact proposes that there is an operation forming a linked chain $\langle \alpha, \beta \rangle$ from chains $\langle \alpha, \gamma \rangle$ and $\langle \delta, \beta \rangle$ where $\gamma = \delta$. Reuland (1995, 1996) adds to this the assumption that the dependency established by agreement is indeed of the type amenable to chain linking.

¹⁷ As is argued extensively in Reuland (1995, 1996), the crucial factor setting grammatical number apart from other φ -features is that it is both optional, and interpretable. Given a slight modification of the conditions on erasure proposed in Chomsky (1995), checking a feature with these properties leads to an illicit erasure, and is thus ruled out.

¹⁸ Long-distance *binding* into infinitival clauses is based on essentially the same mechanism as in Reinhart & Reuland (1991), namely covert verb raising yielding a cluster of more than one verb, freeing the way for the object of the raised verb to be chained to the subject of the I which the verb ends up with in a higher clause.

¹⁹ Note, that in our approach, subjunctive plays a role that is quite opposite to the role ascribed to it in much of the current literature. For instance, Hellan (1988) pictures the subjunctive as an element which explicitly signals that perspective takes precedence over other factors. Within the present approach, however, only morpho-syntactic effects of the subjunctive are involved.

subjunctive morphology. This leaves the option that subjunctive morphology somehow makes it impossible for the two relations to be linked. That is, subjunctive morphology must make the 1 unsuitable as the middle element in the linking operation.

This unsuitability can, in fact, be argued to follow from an independent property of the subjunctive, namely that it must be operator licensed (for instance, by negatives, modals, etc., see e.g. Manzini (1993) for discussion). Assuming this to be a morpho-syntactic property of subjunctive, this licensing relation must be syntactically encoded. Within the framework adopted, such encoding involves (covert) movement of the V/I complex to its licenser. The result is sketched in (16).

$$(16) \quad [[_{OP} [_{V/I} \varphi_{AGR} \varphi_{\alpha}], OP] [DP \dots t_i \dots \alpha]]$$

This operation removes φ_{α} from the position where it can mediate in the chain formation between DP and α . Thus, a chain between DP and an anaphor in the position of α cannot be formed in principle. It follows that there is no way to encode a dependency between α and a possible antecedent in the syntax, hence logophoric interpretation is available.²⁰ (For a more extensive discussion the reader is referred to Reuland (1995, 1996))

Summarizing the results, we note that there are consistent differences between the conditions on long distance antecedents for *sig* in subjunctive and infinitive complement clauses. The interpretation of *sig* in subjunctives is constrained by discourse factors; the interpretation of *sig* in infinitives involves a structural relation with its antecedent. There is no intrinsic necessity for anaphors to be syntactically linked to their antecedent in order to be interpreted, but economy requires that where they can be linked syntactically, they must be. The role of subjunctive morphology is precisely that of blocking a syntactic link. In the logophoric use of *sig* its basic

²⁰ Additional premises required to effectively enforce this conclusion are: i) if ζ (here, the subjunctive) is part of γ (i.e. a sublabel of γ), licensing ζ (by attracting ζ) involves obligatory pied piping of all formal features of γ (here, the V/I complex); ii) subparts of traces are invisible to syntactic operations, in particular, the chain linking operation. Both have independent motivation. (i) is in line with the position argued for in Chomsky (1995) with respect to feature pied piping; (ii) seems at least independently necessary, though at this point, it is not entirely clear to us whether it can be derived, or must be stipulated. Note, furthermore, that the present approach has direct implications for the current debate on whether 'V2'-phenomena in Germanic (V/I to C) fall under the LF or PF part of the grammatical system. With Chomsky (1995) we have to posit that such phenomena are on the PF-side: otherwise, we should obtain the same effect in V2-clauses as in subjunctives.

pronominal properties surface, restricted by an accessibility requirement on its discourse antecedent along the lines of Ariel.

One final remark. Our approach essentially claims that in Icelandic a logophoric interpretation of the anaphor *sig* is made possible by the fact that subjunctive blocks a syntactic encoding of its relation to an antecedent. What about other languages? Napoli (1979) observes that in Italian *se/si* can only have a long-distance antecedent in positions where it cannot cliticize. These are precisely the cases that Clements (1975) considers logophoric. In Reuland (1990) it is argued that cliticization leads to the syntactic encoding of an interpretive dependency. In English, *himself* can have a logophoric interpretation in positions where establishing a syntactic dependency by head-movement of SELF to the verb would be blocked. If so, what we have observed here are manifestations of a deeper regularity: free reflexives are syntactically licensed not by what is the case, but by what is blocked. They arise when they cannot participate in a syntactically encoded dependency.

References

- Anderson, Steven R. 1986. The Typology of Anaphoric Dependencies: Icelandic (and other) Reflexives. In Lars Hellan & Kristi Koch Christensen (eds) *Topics in Scandinavian Syntax*. Dordrecht: Reidel. 65-88.
- Andrews, Avery. 1976. The VP Complement Analysis in Modern Icelandic. *NELS* 6. 1-21.
- Ariel, Mira. 1990. *Accessing Noun-Phrase antecedents*. London: Croom Helm.
- Bernóðsson, H. 1982. Ópersónulegar setningar. Master's thesis. Reykjavík: University of Iceland.
- Bouchard, Denis. 1984. *On the content of empty categories*. Dordrecht: Foris.
- Chomsky, Noam. 1986. *Knowledge of Language: Its Nature, Origin, and Use*. New York: Praeger.
- Chomsky, Noam. 1995. *The Minimalist Program*. Cambridge, Mass.: MIT Press.
- Clements, Nick. 1975. The Logophoric Pronoun in Ewe: Its Role in Discourse. *Journal of West African Languages* 10. 141-177.
- Cornelis, Louise. 1996. *Passive and Perspective* Diss. Utrecht University.
- Everaert, Martin. 1986. *The Syntax of Reflexivization*. Dordrecht: Foris.
- Everaert, Martin. 1990. Case Theory and Binding Theory. *Parametric Variation in Germanic and Romance: Proceedings from the DYNA Workshop*. Center for Cognitive Science, University of Edinburgh. 87-108.
- Hagège, Claude. 1974. Les Pronoms Logophoriques. *Bulletin de la Société de Linguistique de Paris* 69. 287-310.
- Hellan, Lars. 1988. *Anaphora in Norwegian and the Theory of Grammar*. Dordrecht: Foris.
- Hyams, Nina & Sigríður Sigurjónsdóttir. 1990. The Development of 'Long Distance Anaphora': Cross-Linguistic Comparison with Special Reference to Icelandic. *Language Acquisition* 1. 57-93.
- Johnson, Kyle. 1984. Some Notes on Subjunctive Clauses and Binding in Icelandic. *MIT Working Papers in Linguistics* 6. 102-137.
- Koster, Jan. 1984. On Binding and Control. *Linguistic Inquiry* 15. 417-459.
- Lebeaux, David. 1983. A Distributional Difference between Reciprocals and Reflexives. *Linguistic Inquiry* 14. 723-730.
- Lebeaux, David. 1985. Locality and Anaphoric Binding. *The Linguistic Review* 4. 343-363.
- Maling, Joan. 1984. Non-Clause-Bounded Reflexives in Modern Icelandic. *Linguistics and Philosophy* 7. 211-241.
- Maling, Joan. 1986. Clause-Bounded Reflexives in Modern Icelandic. In Lars Hellan & Kristi Koch Christensen (eds) *Topics in Scandinavian Syntax*. Dordrecht: Reidel. 53-63.
- Manzini, Rita. 1993. The Subjunctive. *Paris 8 Working Papers*. Vol. 1.
- Manzini, Rita & Ken Wexler. 1987. Parameters, Binding Theory, and Learnability. *Linguistic Inquiry* 18. 413-444.
- Napoli, Donna-Jo. 1979. Reflexivization across Clause Boundaries in Italian. *Journal of Linguistics* 15. 1-28.
- Pica, Pierre. 1985. Subject, Tense and Truth: Towards a Modular Approach to Binding. In Jacqueline Guéron, Hans G. Obenauer, & Jean-Yves Pollock (eds) *Grammatical Representation*. Dordrecht: Foris. 259-291.
- Pica, Pierre. 1987. On the Nature of the Reflexivization Cycle. *NELS* 17. 483-499.

- Reinhart, Tanya. 1983. *Anaphora and Semantic Interpretation*. London & Sydney: Croom Helm.
- Reinhart, Tanya & Reuland, Eric. 1989. Anaphoric Territories. Ms. Tel Aviv / Groningen University.
- Reinhart, Tanya & Reuland, Eric. 1991. Anaphors and Logophors: An Argument Structure Perspective. In Jan Koster & Eric Reuland (eds) *Long Distance Anaphora*. Cambridge University Press. 283-321.
- Reinhart, Tanya & Eric Reuland. 1993. Reflexivity. *Linguistic Inquiry* 24. 657-720
- Reuland, Eric. 1990. Reflexives and beyond: non-local anaphora in Italian revisited. In Joan Mascaró & Marina Nespó (eds) *Grammar in Progress*. Dordrecht: Foris.
- Reuland, Eric. 1995. Primitives of Binding. Ms. Utrecht University. Presented at GLOW 1995, Tromsø, Norway.
- Reuland, Eric. 1996. Pronouns and Features. *NELS* 1995. Amherst, Mass.: GLSA.
- Rögnvaldsson, Eiríkur. 1986. Some Comments on Reflexivization in Icelandic. In Lars Hellan & Kristi Koch Christensen (eds) *Topics in Scandinavian Syntax*. Dordrecht: Reidel. 89-102.
- Sells, Peter. 1987. Aspects of Logophoricity. *Linguistic Inquiry* 18. 445-479.
- Sigurðsson, Halldór Ármann. 1989. *Verbal Syntax and Case in Icelandic*. Doct. dissertation. University of Lund, Sweden.
- Sigurðsson, Halldór Ármann. 1990. Long Distance Reflexives and Moods in Icelandic. In Joan Maling & Annie Zaenen (eds) *Modern Icelandic Syntax*. New York: Academic Press. 309-346.
- Sigurðsson, Halldór Ármann. 1992. The Case of Quirky Subjects. *Working Papers in Scandinavian Syntax* 49. 1-26.
- Sigurjónsdóttir, Sigríður 1992. *Binding in Icelandic: Evidence from Language Acquisition*. Doct. Dissertation. Los Angeles: UCLA. [Published in 1993 as *UCLA Working Papers in Psycholinguistics* 2.1.]
- Sigurjónsdóttir, Sigríður & Nina Hyams. 1992. Reflexivization and Logophoricity: Evidence from the Acquisition of Icelandic. *Language Acquisition* 2. 359-413.
- Thráinsson, Höskuldur. 1976. Reflexives and Subjunctives in Icelandic. *NELS* 6. 225-239.
- Thráinsson, Höskuldur. 1979. *On Complementation in Icelandic*. New York: Garland.
- Thráinsson, Höskuldur. 1990. A Semantic Reflexive in Icelandic. In Joan Maling & Annie Zaenen (eds) *Modern Icelandic Syntax*. New York: Academic Press. 289-307.
- Thráinsson, Höskuldur. 1991. Long Distance Reflexives and the Typology of NPs. In Jan Koster & Eric Reuland (eds) *Long-Distance Anaphora*. Cambridge University Press. 49-75.
- Wexler, Ken & Rita Manzini. 1987. Parameters and Learnability in Binding Theory. In Tom Roeper & Edwin Williams (eds) *Parameter Setting*. Dordrecht: Reidel. 41-76.
- Yang, Dong-Wee. 1984. The Extended Binding Theory of Anaphors. *Theoretical Linguistic Research* 1. 195-218.
- Zaenen, Annie, Joan Maling & Höskuldur Thráinsson 1985. Case and Grammatical Functions: The Icelandic Passive. *Natural Language and Linguistic Theory* 3. 441-483.

Symmetry and Unity in the Theory of Anaphora

Ken Safir

The primary goal of this paper is to distinguish binding from reflexivity in domains where they appear to overlap. In so doing I will argue that Principles A and B of the Binding Theory are symmetric in the domains to which they apply. This symmetry derives from a deeper unity that permits us to dispense with Principles A and B and replace them with interpretive principles that distinguish reflexivity and binding.*

1 The order of march

Recent theoretical developments in the theory of anaphora have brought new focus to the role of predication relations on the distribution of anaphora. Most notably, Reinhart and Reuland (1991, 1993) and Reuland and Reinhart (1995) have reconceptualized most of binding theory as fundamentally 'about' the distribution of reflexive readings of predicate argument structures (see also Williams (1995)). While I believe this shift away from more traditional binding, based primarily on c-command and other features of tree geometry (such as government), is partially on

* Many people deserve thanks for their assistance in this line of research which I have pursued for many years - too many people to mention here. I would like to thank Pierre Pica, Johan Rooryck and Hans Bennis for getting me involved with this publication and Pierre in particular for his encouragement. I would also like to thank Hans Almgren, Maria Bittner, Frederik Emanuëllson, Toril Fiva, Lars Hellan, Arild Hestvik, Ann Helene Iverson, Alma Naess, Christer Platzack, Kjell Johan Sabo, Inger Sannes-Mueller, Kåre Solfeld, Oscar Swartz, K. Tarald Taraldsen, and Sten Vikner for their help either in preparing the data questionnaires or for their own informant judgments or both. Thanks also to Barry Schein, who read and commented on an earlier draft, to audiences at the U. of Pennsylvania, CUNY, and the Comparative Germanic Workshop at Cornell, and finally, to an anonymous Dutch reviewer, who made a variety of useful comments, some of them directly acknowledged in the notes.

the right track, I will show that the Reinhart and Reuland (R&R) instantiation of the predication approach misses certain generalizations that stem from their conflation of semantic properties with syntactic ones and vice-versa. Though the theory that I propose bears some resemblance to that of R&R, I argue it has greater symmetry, is better supported empirically and enables us to uncover deeper unities.

I begin by challenging the fundamental asymmetry of R&R's system, which resides in their assumption that Principle A is uniquely syntactic while Principle B is uniquely semantic. More specifically, R&R claim that Principle B applies at a semantic level to predicate argument structure relations, while the residual effects of traditional Principle B (e.g., that in Chomsky (1981)) are derived by an independent theory of chains. However I will demonstrate that the chain theory they propose is merely a reintroduction of syntactic Principle B, just as specific to pronouns as the original Principle B. The result is the existence of two Principle Bs, one syntactic and ultimately familiar, one semantic and novel. Though I critique their syntactic Principle B and its relation to syntactic Principle A, I argue, on the other hand, that what appear to be two distinct Principle B-like prohibitions may indeed be required and that they apply at the levels they propose.

I then show that R&R's syntactic Principle A fails to make crucial distinctions between two Mainland Scandinavian anaphors it would appear to apply to, SIG-SELF and pronoun-SELF, with the result that a semantic Principle A, parallel to semantic Principle B, is motivated.

Since the system I propose depends crucially on a licensing design — anaphors must receive an interpretation in the course of a derivation in order to be licensed — it is necessary for me to explore the distribution of anaphors where they have no antecedent in sentence grammar, or else have an arbitrarily distant antecedent. Such anaphors are typically called logophors. Though I argue that R&R's version of the partition of binding phenomena into logophoric and non-logophoric uses of anaphors is both internally inconsistent and an oversimplification of the range of variation, some of the counterevidence to their proposal enables us to better understand deeper, empirically supported properties of the conditions that regulate when an anaphor may be employed as a logophor.

The introduction of semantic Principle A produces a symmetric theory of binding (two Principles A and two Principles B). The symmetry goes deeper, in that the domains of syntactic A and B are essentially identical, once a basic asymmetry in antecedency requirements is admitted (recalling Huang (1983) and Chomsky (1986a)). The identity of their domains then permits a reduction of syntactic Principles A and B to a single principle, which, moreover, is demonstrably not 'about' reflexivity, but

about bound readings. By contrast, semantic Principle A and semantic Principle B are both 'about' reflexivity in its traditional sense, share the same domain and thus may also be unified into a single principle of Reflexive Interpretation.

1.1 The R&R theory

As a prelude to what follows, it is useful to present the central mechanisms of the R&R predication-based approach, the heart of which are Principles A and B as stated in (2) along with the ancillary definitions in (1) (drawn from Reuland and Reinhart (1995:247)).

(1) Definitions

- a) the **syntactic predicate** of (a head) P is P, all its syntactic arguments and an external argument of P (subject)
the **syntactic arguments** of P are the projections assigned theta-role or Case by P
- b) the **semantic predicate** of P is P and all its arguments at the relevant semantic level
- c) a predicate is **reflexive** iff two of its arguments are coindexed
- d) a predicate (of P) is **reflexive-marked** iff either P is lexically reflexive or one of P's arguments is a SELF-anaphor

(2) Conditions

- a) a reflexive-marked syntactic predicate is reflexive
- b) a reflexive semantic predicate is reflexive-marked

To see how this works, consider (3-5)). In (3a) the pronoun cannot have a bound interpretation because the predicate *criticize* would not be reflexive-marked. Principle A correctly predicts, however, that (3b) is grammatical, since it is reflexive-marked. If *himself* has an index other than "i", then (3b) would violate Principle A, since a reflexive-marked predicate must have a reflexive interpretation.

- (3) a *Max_i criticized him_i.
- b Max_i criticized himself_i.

Principle A is stated on syntactic representations, or else (4) would not be grammatical, given that *John* is not the semantic subject of *appear*. Rather it is the

syntactic subject of *appear*, hence it is the notion of syntactic subject that is relevant to Principle A, they reason.

- (4) John_i appears to himself_i to be a genius.

The evidence that Principle B refers to more semantically complete representations comes from distributively interpreted conjunctions as in (5a) as interpreted in (5b).

- (5) a The queen invited Max and her (to our party).
b The queen (1x (x invited Max & x invited x))

Under the interpretation (5b), the bound interpretation for the pronoun is excluded because Principle B applies to it - "x invited x" is not reflexive-marked. R&R assume that the collective interpretation of (5a) is grammatical (the pronoun is not in a reflexive relation with the subject). Thus, R&R conclude, Principle B must be stated on the semantically relevant structure. In section 4.2 I will support this conclusion.

If Principle B is stated on semantic representations, however, then some cases covered by traditional syntactic Principle B are no longer excluded by semantic Principle B. If a pronoun is substituted for the reflexive in the raising case in (4) as in (6a), the pronoun is not excluded by semantic Principle B. Nor is the pronominal subject of an ECM construction, as in (6b).

- (6) a *John_i appears to him_i to be a genius.
b *John_i believes him_i to be a genius.

These examples do not fall under semantic Principle B, but they do fall under the Condition on A-chains that R&R (1995:255) propose, as stated in (9) assuming Chomsky's (1986b) definition of government in (8) and the chain definition in (7).

(7) **Generalized Chain Definition**

$C = (a_1, \dots, a_n)$ is a chain iff C is the maximal sequence such that

- i) there is an index i such that for all j , $1 \leq j \leq n$, a_j carries that index; and
ii) for all j , $1 \leq j < n$, a_j governs a_{j+1} .

- (8) α governs β iff α m-commands β and there is no τ , τ a barrier for β , such that τ excludes α .

- (9) Condition on A-chains: a maximal A-chain (a_1, \dots, a_n) contains exactly one link - a_1 - which is [+R].

The condition in (9) which requires of the maximal chain of (7) that it include only one [+R] "referential" element should not be confused with Principle C, since commanding antecedents for Principle C do not have to govern names to exclude them. Moreover the chains conditioned by (9) are not the entities that theta-assignment applies to, or else *John loves himself* would be excluded because two theta roles inhabit the same chain.

These potential confusions aside, consider how these definitions apply. In examples like (3a) and (6a,b), there is no barrier between *him* and its antecedent, if it is assumed that the higher VPs (headed by *appear* and *believe*) are not barriers in relation to the prepositional object or the ECM subject, respectively. In order for the matrix subject to count as an antecedent for a pronoun in (7-9), it either must be assumed that the pronoun moves to the SPEC AGR-O (of the higher clause, in the case of (6b)), voiding the barrierhood of the matrix VP, or else it must be assumed that I is an L-marker (within the assumptions of the Barriers framework). Similarly it is assumed that PP is not a barrier in (4), since the P is selected by *appear*.

One of the main purported advantages of introducing the Condition on A-chains in (9) is that the distribution of Germanic SICH-type morphemes as they contrast with personal pronouns suddenly appears tractable. As R&R point out, pronouns cannot be ECM subjects in Dutch as in (10), since they would violate (9), but *zich* can, since *zich* (and *zichzelf*), by hypothesis, is [-R] (as is German *sich*, which I will refer to together as "SICH").

- (10) Henk, hoorde [zichzelf/zich/*hem, singen].
 Henk heard [himself/SICH/him sing]

Another purported advantage of this reformulation is that neither SICH nor a pronoun is excluded in intrinsic reflexive constructions by Principle B, since these predicates are inherently reflexive-marked (in the lexicon).

- (11) a *Willem, schaamt hem.
 b Willem, schaamt zich.
 Willem shames him

The addition of *sich* or pronoun does not double-mark the predicate *schamen* as reflexive (though *zichzelf* presumably would, which they suggest is excluded under some notion of economy). Thus semantic Principle B helps to predict that *zich* is possible with a coargument antecedent just in case the predicate is inherently reflexive

marked. What excludes (11a), as opposed to (11b), is (9), which does not allow a [+R] element such as a pronoun to be bound within the domain of the first barrier above its governor. Once again, since SICH is [-R], (9) does not exclude it.

2 Two B's or not two B's ?

The chain theory proposed by R&R invites criticism on two fronts. The first concerns the fact that the Condition on A-chains (9), except for regulating the distribution of some pronouns, lacks independent motivation. Secondly, the notion [+/-R], despite their attempt to give it predictive force, is ultimately descriptive (of pronouns), as I will show.

2.1 The scope of the Condition on A-chains

Setting aside, for a moment, the notion [+/-R], it is clear that the distribution of non-anaphoric non-pronominals in no way motivates the Condition on A-chains (9). That is to say that (9) is redundant for names in those cases where the binder is sufficiently local. Anything that counts as a name with respect to Principle C (or whatever achieves the effect of Principle C) is excluded if bound at all, so no independent motivation for (9) is to be found for names, which are excluded by binders that do not govern them as well as those that do.

The Condition on A-chains is admitted to be redundant for all cases where semantic Principle B holds sway. Moreover (9) is unnecessary for SELF anaphors, which are independently regulated by Principle A. Thus it is straightforward that (9) is only crucially motivated by the distribution of SICH and pronouns not falling under semantic Principle B.

The definition of chains in (7) is not independently useful outside of its relevance to the entities picked out by (9). As mentioned earlier, the A-chains relevant for theta-assignment which must avoid two theta-roles within a chain cannot be the sorts of chains that (9) applies to. Thus there is no independent motivation for the chain entities in question, except the regulation of SICH and the offending residue pronouns.

If the chain entity which (9) applies to is unmotivated, then we may ask if this condition is in fact specific to pronouns. The answer appears to depend on the independent motivation for [+/-R], which I will examine below, but first consider how the Condition on A-chains, applying to the distribution of [+R] elements,

compares with a version of traditional Principle B (following Huang (1983), I assume that SUBJECT is not part of the domain for Principle B).

- (12) a Force of the Condition on A-Chains: a [+R] element must be free within the domain of the first barrier that dominates it.
 b Syntactic Principle B: A pronoun must be free within the minimal functional complex containing its governor.

Suppose that we were to revise syntactic Principle B to state it in terms of barriers, with the assumption (adopted by R&R) that VP is not a barrier for Accusative assigned object (either a direct object or ECM subject). The force of syntactic Principle B then depends entirely on the same sorts of considerations that the Chain Theory would have to consider. For example, if (13) is considered grammatical, then DP must be a barrier for *him*, in the chain theory or for syntactic Principle B stated in terms of barriers, but not if (13) is considered ungrammatical.

- (13) %John_i saw a picture of him_i.

Thus all that remains of (9) will now reduce to syntactic Principle B with an added diacritic if indeed the [+R] designation is restricted to pronouns.

2.2 The scope of [+R]

R&R (1995) consider an element [+R] if it is fully specified for number, Case and gender. The SICH elements are never specified for gender or Case and often not for number. The supposed intuitive appeal is that if the feature matrix for SICH elements is not completely specified, then they cannot be referential.

However, the proper name *Marion* is not specified for Case or gender. One can refer to Maid Marion, a mythic female of the Robin Hood legend, or Marion Morrison, a mythic male (known by his stage name, John Wayne), but it is only through real world knowledge that one can attach a gender to the name. If so, the name is not independently motivated to be [+R]. But presumably such elements must be [+R] because they can successfully head chains. Without knowing anything about the real world gender value for *Marion* one can report *Marion left* a grammatical sentence.

Similarly, *someone/anyone/everyone* etc. are not specified for gender or Case, yet *Someone left* and *He saw someone* are grammatical. One can say that if an element

has more than ϕ -features then it doesn't have to have full feature specification to be [+R], but this is just another way of reducing the force of (9) to pronouns and SICH elements, especially since SELF elements are independently regulated by Principle A and reciprocals are not discussed (nor will they be here). Thus the [+/-R] designation is now effectively stipulated to apply to SICH and pronouns, since extending [+R] to names and quantifiers is thoroughly ad hoc, if gender and Case are criteria.¹

Let us examine the now very narrow [+/-R] distinction, which serves as a gate-keeper for the elements that the chain theory applies to. One claimed benefit of the distinction is that R&R can account for the otherwise problematic Frisian fact illustrated in (14).

- (14) Max hâld him/*himsels.
Max behaves him

If *him* in Frisian were [+R], then (14) would be excluded by (9), just as (11a) is. However R&R argue that Frisian *him* is indeed [-R], because inherently Case-marked elements should count as unspecified for Case, unless, as in German, they participate in Case contrasts (i.e., in German, an oblique selected pronoun has a specific Case selected by the relevant preposition). Thus (9) accounts for the grammaticality of (14) in Frisian, where traditional binding theory would be forced to rule it out.

It is certainly appropriate to seek an independent motivation for the contrast between Frisian and Dutch, but the question is whether this particular formulation of the contrast, which seems dubious, has any real intuitive relation to a coherent notion of [+R].² The same sort of distinction could easily be tacked on to syntactic Principle B by providing some sort of diacritic (on those elements consisting solely of phi-features) as to whether or not syntactic Principle B applies to them. The force of

¹ A reviewer points out that sex and gender are distinct, which is obviously true, but not relevant here, since in English, sexual identity is all that determines what gender might be for names and quantifiers. Claiming that the abstract gender marking on names and quantifiers corresponds with whatever the sexual identity happens to be is thus a thoroughly unfalsifiable way to defend [+R]. In short the [+R] proposal is unmotivated for names, as maintained in the text.

² Clahsen, Eissenbeiss and Vainikka (1994) have argued that the acquisition of non-Nominative Case is never overgeneralized in acquisition though Nominative Case is. They argue specifically, as does Weerman (1996), that non-Nominative Case, hence intrinsic Case, is always specified. However these arguments are for German, where intrinsic Case is in contrast, according to R&R (1995). A similar study of Frisian, for example, might help to settle the matter.

this diacritic, as in the R&R theory, is that it sets aside *SICH* forms with respect to syntactic Principle B without requiring that they fall under Principle A. Let us call that diacritic [+/-pronoun]. The motivated portion of (9) now reduces to Principle B, stated on barriers, with the [+/-pronoun] diacritic in place of the less precise term "pronominal".^{3,4}

- (15) **Syntactic Principle B:** A [+pronoun] element must be free in the domain of the first barrier that dominates it.

To conclude, R&R's theory surreptitiously proposes two Principle B's, one semantic and novel, the other syntactic and quite conventional.

2.3 Syntactic Principle B vs. the Condition on A-chains

But suppose the Condition on A-chains (9) does reduce to syntactic Principle B; then where is the harm in maintaining (9) as an entity only indirectly related to binding theory?

The problem is that syntactic B stated as (9) misses a parallel with Principle A that was captured in the traditional binding theory. In canonical Accusative positions, such as direct objects and ECM subjects, pronouns and *SELF*-forms (in the languages that have them) are always in complementary distribution (including in Frisian). This was so in the traditional binding theory because government was part of the domain determinations for both Principle A and Principle B. In the R&R theory, barriers are invoked (through (8)) for (9), whereas stipulated Case assignment is invoked for Principle A (crucially in ECM environments, for example). Moreover, R&R's definition of a syntactic predicate (relevant to Principle A) includes a predicate and its semantic arguments, an external argument (in case it doesn't have one) and anything it assigns Case to. This unintuitive conglomeration preserves Principle A

³ My use of the barriers formulation is for convenience of presentation, but later I will abandon it for one based on 'functional complex'. Any theory that permits the domain in question to include the subject of a predicate and any position it licenses A-movement from in its complement (as in Chomsky (1993)) will do at this point.

⁴ No one has proposed that *SICH* forms are exclusively susceptible to Principle B. Everaert (1991) treats them as pronominal anaphors that exploit differences in domain sizes between Principles A and B but that are regulated by both principles. Many others treat *SICH* forms as anaphors that undergo movement e.g. Pica (1987). Safir (1996) treats *SICH* forms as susceptible to neither A nor B, a position much closer to that of R&R.

very much as it is in traditional binding theory and bears no relation (unlike semantic Principle B) to any natural notion of reflexivity. How is a predicate reflexive for a predicate *P*, in any semantic intuitive sense, if an argument of *P* is coindexed with a semantic non-argument of *P*? Put this way, the claim that syntactic reflexivity is something different is to say that syntactic reflexivity is a thoroughly artificial notion and is thus no improvement over the use of government to define the relevant binding domain.

In short, the claim that the reflexivity of predicates is only relevant to syntactic Principle A introduces an artificial asymmetry with respect to syntactic Principle B that obscures the relationship between the two. On the other hand, the relevance of reflexivity to semantic Principle B is unaffected by this critique.

3 Semantic Principle A and Mainland Scandinavian anaphora

The conclusion of section 2 leaves us with a potential symmetry in syntax between Principles A and B that is not matched at the relevant semantic level where only semantic Principle B prevails. In this section I will argue to restore symmetry to the theory by establishing evidence for the existence of a semantic Principle A.

Given that I am arguing that more than one principle regulates the distribution of reflexive anaphors, I must provide evidence that there are contexts where the only semantic principle regulates a distinction, a distinction that is neither syntactically based one nor logophorically based. The latter consideration is necessary because R&R claim that any SELF-form not regulated by their Principle A is available for, indeed must have, a logophoric usage. The exact version of their theory that is at issue is examined in the next section, but for this section it suffices to say that if an anaphor cannot have an appropriate antecedent in syntax, e.g., it is embedded in a conjunct, then it is a logophor in the R&R system. In languages where the right distinctions can be observed, however, it can be shown that syntactic Principle A and logophoricity in the R&R approach fail to make some finer cuts that are required. I have in mind the four way contrast between SICH forms, pronouns and the two SELF-forms of Mainland Scandinavian (MS), SIG-SELF and pronoun-SELF.

Danish, Norwegian and Swedish differ very slightly in what follows, but I will abstract away from these minor differences insofar as they have no import for what I have to say. Roughly speaking, in all of the MS languages, there is a SIG form (where SIG ranges across Danish and Swedish *sig* and Norwegian *seg*) that cannot be bound by a semantic coargument, except for inherent reflexive constructions (much

like Dutch *zich*). Pronouns cannot be coreferent with semantic coarguments (as is the general case) and the SELF-forms are most typically bound by a semantic coargument (in particular, see Hellan (1988: 69-70)). (The term "SELF" ranges across Norwegian and Danish *selv* and Swedish *själv* as well as English *self* and other cognates, though its behavior is mediated by language particular properties and the sorts of compounds it forms, see Safir (1996)). However the MS SELF-forms bifurcate when bound by a semantic coargument in the following way: pronoun-SELF cannot be bound by a subject and SIG-SELF must be bound by a subject. The basic data used to establish the empirical generalizations about locality are drawn from Vikner (1985) for Danish (D), from Hellan (1988) for Norwegian (N), from Riad (1988) for Swedish (S) with additional judgments from my own informants for all three languages.

- (16) a ...at Susan fortalte Anne om ____ (D)
 that Susan told Anne about ____
Susan: *hende, *hende selv, *sig, sig selv
Anne: *hende, hende selv, *sig, *sig selv
- b ...at Susan bad Anne, om PRO_j at ringe til ____ (D)
 that Susan asked Anne for PRO to ring to ____
Susan: hende, *hende selv, sig, *sig selv
Anne: *hende, *hende selv, *sig, sig selv
- (17) a Harald fortalte Jon om ____ (N)
 Harald told Jon about ____
Harald: *ham, *ham selv, *seg, seg selv
Jon: *?ham, ham selv, *seg, *seg selv
- b Jon bad oss snakke om ham/*ham selv/seg/*seg selv (N)
 Jon, asked us to-talk about ____
- (18) a Karl talade med Olle om ____ (S)
 Karl talked to Olle about ____
Karl: *honum, *honom själv, *sig, sig själv
Olle: *honom, honom själv, *sig, *sig själv
- b Johan bad Kalle, PRO_j tvätta ____ (S)
 Johan asked Kalle to-wash ____
Johan: honom, *honom själv, sig, *sig själv
Kalle: *honom, *honom själv, sig, sig själv

The examples in (16a,17a,18a) indicate all the possibilities for the most local (coargument) domain and (16b,17b,18b) illustrate the pattern where tensed clauses

create opacity effects, respectively. The possibility for *sig* in (18b) to refer to *Kalle* or *Johan* is due to the fact that 'wash' may have an inherent reflexive interpretation which permits the PRO subject of the infinitive (*Kalle*) to be the antecedent of *sig*.

The difference between pronoun-SELF and SIG-SELF in local domains involves (anti-)subject orientation, a phenomenon I will not discuss until section 6.2 (where it is largely set aside), except in a strictly diagnostic way that emerges in my discussion of logophoricity.⁵ However another interesting difference between these two SELF-forms emerges when they are embedded in contrastive predicates and are bound at a distance, a matter I will turn to in section 4.3.

Let us focus first on the locality restrictions that hold of the SELF-forms, particularly of SIG-SELF. Of particular interest here is the difference in distribution between pronouns and SIG-SELF in conjunctions. We must consider two cases, as in English — a collective interpretation and a distributed one.

In (19), for example, where informants were given a specific choice between two interpretations, the distinction noted is robust. In (19a) the collective interpretation was exemplified when the data was presented as describing a situation where Jon is talking only about his life together with Lea, whereas in (19b) the distributed interpretation was exemplified as one in which Jon is talking only about two lives, his own, and Lea's.

- (19) a Jon snakkede kun om Lea og ham/*sig/*ham selv/*sig selv. (D)
 'Jon talked only about Lea and himself.'
 b Jon snakkede kun om Lea og *ham/*sig/*ham selv/sig selv. (D)

The distributive interpretation which corresponds to a parallel conjunct representation requires SIG-SELF. Collective interpretation for the conjunction, the one that could not be represented accurately by a parallel conjunct analysis at the semantic level, requires the use of a pronoun. If informants are pressed to find a distinction between pronoun-SELF and SIG-SELF in the collective case, pronoun-SELF is always favored over SIG-SELF, but neither is acceptable in comparison with the pronoun. SIG is excluded in conjuncts generally, though I will have little to say about the matter (see 6.2).

⁵ The fact that both SIG and SIG-SELF are subject oriented and pronoun and pronoun-SELF are not suggests that SIG is a subject-oriented decomposable part of SIG-SELF, as argued by Hellan (1988:102), for example.

Recall now the R&R analysis of collective interpretations vs. distributed ones in English, the latter illustrated earlier in (5b). For the distributive interpretation, as represented by a parallel conjunct analysis for (19b) (i.e., along the lines of (5b)), R&R correctly expect the pronoun to be excluded because it is in a reflexive talk-about relation at the semantic level and 'talk about' is thus not reflexive-marked. However both SELF- forms should be logophoric, since they are not in reflexive structures at the syntactic level where Principle A applies. Here the SELF-forms are only distinguished by subject orientation, it seems. For the collective interpretation, where the referentially dependent element is not in a reflexive relation with 'talk about' at the semantic level, the pronoun is correctly predicted to be acceptable, since it is not in a reflexive relation with respect to the predicate 'talk about'. However, R&R still predict that both pronoun-SELF and SIG-SELF are logophoric, clearly a false prediction in the latter case.

Matters become clearer when we consider conjuncts that are more deeply embedded with respect to their antecedent. Where a parallel conjunct analysis does not render SIG-SELF a clausemate to its antecedent, R&R predict SIG-SELF is a logophor, but in fact it is simply excluded, as illustrated in (20).

- (20) Carl_i sagde at Jon ikke vil fortælle Marie om Lea og ham/ham selv/
 *sig selv_i. (D)
 Carl_i sa at Jon ikke vil fortelle Marie om Lea og ham/ham selv/
 *seg selv_i. (N)
 'Carl says that Jon will not tell Marie about Lea and ____.'

(20) would be grammatical with SIG-SELF at the level of semantic representation if its antecedent were *Jon* but *Carl* is not in a reflexive relation with SIG-SELF, hence the sentence is excluded unless either a pronoun or pronoun-SELF is employed. That pronouns coindexed with the matrix subject are not excluded in (20) is expected, since the pronoun is not in any reflexive relation under either collective or distributive interpretation.

What appears to be going on is that SIG-SELF is grammatical where it meets the requirements of a semantic Principle A, applying in the same way as semantic Principle B does with complementary results. Where pronoun is acceptable, as in the collective interpretation, SIG-SELF is not, and where SIG-SELF is acceptable, as in the parallel conjunct interpretation, a pronoun is excluded.

Summarizing, R&R's syntactic Principle A should straightforwardly predict that both SIG-SELF and pronoun-SELF are logophors when they are in any conjunct (for

clarification, see the next section), yet SIG-SELF, as opposed to pronoun-SELF, is in fact excluded where it does not have a semantically local analysis, as in (20) (as opposed to (19b)). I conclude that SIG-SELF is regulated by semantic Principle A on the same sort of evidence that that supports the application of semantic Principle B, namely, SIG-SELF is only acceptable in contexts where it forms a semantically reflexive predicate.

Clearly an account of the domain of logophoricity for pronoun-SELF (as in (20)) as opposed to SIG-SELF remains an open question, one not addressed by R&R. This and other issues I defer to later sections.

4 More on the logophoric/anaphoric distinction and Principle A

Now I turn to a slightly different set of concerns that presage the theory I will propose in section 5, where it is argued that anaphors are licensed by the principles that apply to them. Uninterpreted anaphors are unlicensed and excluded. Once again, R&R's theory provides a useful presentational contrast to the one I will propose, particularly with respect to the problems it fails to solve or fails to address.

A key partition in the R&R theory is between those SELF-forms regulated by syntactic Principle A and those SELF-forms that, by failure to participate directly in predicate relations, must be logophorically employed. Although it is clear that some SELF-forms are made available to discourse antecedent interpretation by virtue of their syntactic and semantic context, I will show that R&R's notion of syntactic predicate does not make quite the predictions they claim it does, nor, as we saw in the last section, does it make the right predictions concerning which SELF-forms can be discourse-antecedent.⁶

4.1 R&R on logophoric interpretation of SELF-forms

R&R make the following proposal: Condition A (=2a) governs the bound versus the logophoric use of SELF-anaphors. It implies that SELF-anaphors can be

⁶ Two assumptions need clarification here. First, I use the term "logophoric" as a matter of convenience for those cases where elements typically employed as anaphors are anteceded by pragmatically determined antecedents, whether those antecedents are determined by point of view, center of consciousness, or some pragmatic notion of contrast (see Sells (1987), Zribi-Hertz (1989), C.L. Baker (1994) and references cited there for discussion). However not every reflexive that is logophorically employed will be accounted for here — see fn. 22.

logophoric only in cases where they are not in an argument position of a syntactic predicate. This accounts for the contrast between the sentences in (21) and those in (22). In (21a-c) the SELF-anaphor is not an argument of a syntactic predicate; hence condition A does not apply and a logophoric interpretation is possible. In (22a-c) the SELF-anaphor is an argument of a syntactic predicate. As a consequence, condition A requires that the predicate be reflexive; since no two positions are coindexed, it is not and condition A is violated.

- (21) a There were five tourists in the room apart from myself.
 b Physicists like yourself are a godsend.
 c Max boasted that the queen invited Lucie and himself for a drink.
- (22) a *Five tourists talked to myself in the room.
 b *A famous physicist has just looked for yourself.
 c *Max boasted that the queen invited himself for a drink.

However this account of (21a) and (21b) is at the least misapplied, given the definitions in (1a), since *apart from* assigns Case to *myself* just as *like* does to (which, if a pronoun is substituted for the reflexive, is always Accusative, or at least non-Nominative). This means that these elements are indeed syntactic arguments. Moreover, there is no clear semantic reason, if one must even appeal to one, why *like* and *apart from* should not be considered predicates, since they express a relation between two arguments just as the predicates *hit* or *angry at* do, or even spatial predicates such as *adjacent to*. However the relevant distinction would have to be syntactic in R&R's terms, since Principle A is syntactic, and yet nothing other than an ad hoc classification would treat these cases differently if only syntactic factors are considered.

In fact, as explored in detail in Safir (1992), the semantic class of predicates including *like* very often appears in copular constructions the same way other adjectives do as in the comparisons in (23), yet other adjectives do not induce the same logophoric effects, as illustrated in (24). A list of similarity predicates (from Safir (1992)) appears in (25).

- (23) a Darby is fairly deferential/similar to Selena.
 b Esther is quite estranged/different from Daffy.
 c Angela is rather angry at/like Andrea.

- (24) a Sissy insists that Darby is fairly similar/*?deferential to herself.
 a' Etta attacks people similar/*?deferential to herself.
 b Theo says Esther is quite different/*?estranged from himself.
 b' Thor threatens people different/*?estranged from himself.
 c Otto admits that Mary is rather like/*angry at himself.
 d Abraham always abhors someone like/*angry at himself.
- (25) Similarity Predicates:
like, unlike, similar to, different from, identical to, such as

While the similarity predicates, all having to do with identity of person or properties in relation to another, all permit the logophoric effect, none of the non-similarity predicates do. The R&R account predicts that none of these predicates permit logophoricity if they apply their definition carefully. However even if the definition is interpreted the way they intend, that is, if they interpret it to mean that *similar to* is not a predicate and that it does not assign Case, then presumably they must say the same thing about adjective plus preposition units like *deferential to, angry at* and *estranged from*. Either way, they fail to make a significant distinction because they fail to take into account the semantic force of the predicates involved.

Predicate-like elements such as *apart from*, called exclusion predicates in Safir (1992), have a different semantic status from those like *like*. Exclusion predicates are not possible in copular environments, yet they also are typically two place relations and all arguably assign Case.

- (26) Exclusion Predicates: *apart from, but, rather than, except, save, besides, other than, in addition to, including, excluding*
- (27) *Hillary is apart from/rather than/other than Bill.

By the latter criterion, the SELF-forms are syntactic arguments in the R&R account if exclusion predicates are indeed predicates. Yet all of these exclusion contexts permit logophoric behavior.

- (28) Dole pointed out that the Republicans would look foolish if anyone other/rather than/apart from/except/save himself were nominated.

The incompatibility of exclusion predicates with copular contexts may seem a plausible objection to treating exclusion relations as predicates, but many non-verbal

relational forms typically treated as predicates do not appear in copular environments, such as nominals.

- (29) a Hinckley's attack on Reagan
 b *Hinckley is attack on Reagan

One does not argue on the basis of (29b) that *Hinckley* is not the relational agent of the attack under the event interpretation of the nominal, even under theories like those of Grimshaw (1990) or Safir (1987). Moreover, Genitive specifiers of nominals show specified subject effects, as in (30).

- (30) Lea_j was offended by Janet's_i attack on herself_{i,j}.

Even more conclusive are cases like (31) where non-agentive *exclude* and *include* may act as verbs. R&R do not expect logophoricity for *himself* for (31c) any more than they expect it for (31d), which illustrates the crucial distinction their theory lacks.⁷

- (31) a These facts include that one.
 b These possibilities exclude that one.
 c ?Powell rejects any list of candidates which excludes/includes himself.
 d *?Powell rejects any list of candidates which describes himself.

I conclude that exclusion predicates are predicates and as such they are just as problematic for R&R as the similarity predicates are. Thus the R&R theory fails badly to account for the freedom of SELF-forms to choose antecedents from discourse, even though this is clearly a phenomenon they intend to capture. However I have not yet shown that any other theory makes superior predictions for these cases.

4.2 More evidence for semantic Principle B

Exclusion predicates, as opposed to similarity predicates, generally show Principle B effects. For example, unless *him* is stressed in (32a), it cannot be coreferent with the subject of *hate*. The pronoun can be reduced only if it is not coreferent with

⁷ Although (31c) requires some stress on *self* to be acceptable, similar stress in (31d) still yields a clear contrast between (31c/d).

Powell. (Controlling for stress in (32a,b) is easier if the exclusion predicate, as opposed to the pronoun or SELF-form, is contrastively stressed).

- (32) a Hal_i hates everyone except/besides/other than HIM/*him/himself/him_i.
 b Powell_i pointed out that any thorough list of candidates would have to exclude/include HIM/*'im/'im_i.

Such cases are discussed in detail in Safir (1992), but their relevance here is that R&R require a very particular sort of analysis to assure the Principle B effect, namely, they must assume a semantic representation intuitively like (33) (compare (5h)), as suggested in R&R (1991).

- (33) Hal (lx (x hates everyone & NOT (x hates x)))

Following R&R (1991:314-15) I do not intend (33) as a serious semantic representation, particularly since *everyone* must be construed to allow that (33) is not a contradiction, but the crucial part is that one conjunct embeds a reflexive predicate that is not reflexive-marked.⁸ Predicates of the similarity class do not show the same effect, since the intuitive translation of (34a) is neither (34b) nor (34c).

- (34) a Hal_i hates everyone similar to him/himself/'im_i.
 b *Hal (lx (x hates everyone and x hates similar x's))
 c *Hal (lx (x hates everyone and similarly (x hates x)))

Since there is no parallelism of interpretation, semantic Principle B does not apply to pronouns in similarity predicates, as desired, consistent with R&R's approach (whether or not similarity predicates are considered predicates). In short, exclusion

⁸ The intuition that links all of the exclusion predicates is that some set is subtracted from a larger one and the subtracted set has its own relation with the matrix predicate (normally the matrix verb). The correct semantics will hopefully link the subtraction intuition and the parallel conjunct analysis. For discussion of the semantics of some such predicates and references, see von Stechow (1992). However von Stechow does not consider exclusion predicates like *other than* which can cooccur with *someone* (not just negation and universals, which is true of *but* and *except*) yet still involve the notion of a subtracted set. For example, in *John met some linguist other than Bill*, given the set M, which is the set of entities John met, the set L, consisting of linguists, and the set B consisting of Bill and B is in L: the intersection of M, L and B'. B' the complement set of B (i.e., Bill subtracted), contains at least one member. In terms of the parallel conjunct analysis, John met x, x a linguist, and it is not the case that John met Bill (though Bill is a linguist).

predicates lead to semantic parallel conjunct representations (or whatever captures the parallelism intuition), but similarity predicates don't.

Thus, consistent with the R&R approach to Principle B, the contrast between similarity predicates and exclusion predicates with respect to the distribution of pronouns does seem to suggest that Principle B should be stated on a level where the semantic sense of reflexivity is expressible.

4.3 MS anaphora in exclusion and similarity contexts

Consider now what happens when MS similarity predicates (35b,e) and MS exclusion predicates (35c,d) are contrasted, and how these kinds of predicates in turn contrast with predicates that do not induce the same effects (35a).^{9,10}

- (35) a Jon vil giftes mød en kvinde som er stolt af ham/*ham selv/*sig/
 *sig selv. (D)
 Jon vil gifte seg med en kvinne som er stolt av ham/*ham selv/*seg/
 *seg selv. (N)

⁹ Since this data, distilled from a much larger set, is complex, it is important to make clear how it has been interpreted. Native informants found exclusion and similarity predicate domain judgments difficult, but when pressed to make some distinction the ones they chose converged remarkably, especially over a wide set of examples. Speakers who have the most judgments in common tend to be those most liberal or else those least liberal, rather than speakers of one MS language vs. another, or linguists vs. non-linguists. Some speakers seem to have employed the five point scale differently (OK, slightly off (?), fairly bad, but possible (??), very bad (**), or hopeless(*)), although the same pattern of relative distinctions obtain. To save space, I do not always provide examples in all three MS languages, though I have data for all three for almost every example.

¹⁰ MS speakers differ as to the acceptability of attributive adjective phrases (e.g. *someone different from Bill*), and even those who accept them do not find them natural. A relative clause structure is preferred. However the logophoric effect is only more dramatic when the subject of the relative is somehow skipped as an antecedent. For one speaker, however, similarity predicates contrast based on whether or not the adjective is part of a reduced relative or a full one. If it is reduced, this speaker treats the similarity complement as if it were a matrix predicate argument, contrary to expectation, although complementarity between SIG-SELF and pronouns is maintained. This is shown in (i) and (ii).

- (i) Jon, kommer inte att berätta för Per om någon annorlunda än *?honom/sig själv. (S)
 'Jon will not tell Per about anyone different from ____.'
- (ii) Jon, brukade avsky folk som var annorlunda från ?honom/honom själv/*sig/*sig själv. (S)
 'Jon used to hate people who were different from ____.'

Jon vill gifta sig med en kvinna som är stolt över honom/*honom själv/*sig/ *sig själv. (S)

'Jon will marry (D-pass/S&N-himself) with a woman who is proud of himself.'

- b Jon plejede at hade folk som var anderledes end ?ham/ham selv/*sig/*sig selv. (D)

Jon pleide å hate folk som var anderledes enn ham/ham selv/*seg/*seg selv. (N)

Jon brukade avsky folk som var annorlunda än honom/honom själv/*sig/*sig själv. (S)

'Jon used to hate people who were different from him.'

- c Carl sagde at Marie havde snakket med alle andre end ____. (D)

Carl sa at Marie hadde snakket med alle andre enn ____. (N)

Carl sade att Marie hade talat med alla andra än ____. (S)

'Carl said that Marie had talked to all others than ____.'

Carl (D): ham, ?ham selv, *sig, *sig selv

(N): ham, ham selv, *?seg, *seg selv

(S): honom, ?honom själv, *sig, *sig själv

Marie (D): *hende, hende selv, *sig, sig selv

(N): *henne, */?henne selv, *seg, seg selv

(S): *henne, ?henne själv, *sig, sig själv

- d De her mænd hader alle inklusive/undtagen ____. (D)

Disse mennene hater alle medregnet/unntatt ____. (N)

Dessa män avskyr alla inklusive/undantaget ____. (S)

'These men hate all including/excluding ____.'

(D): *dem, dem selv, *sig, *sig selv

(N): *dem, dem selv, *seg, seg selv

(S): *dem, OK/??dem själva, *sig, sig själv

- e Jon sagde at han aldrig ville tillade in datter sa meget som at overveje at gifte sig med en mand helt forskellig fra ?ham/ham selv/*sig/*sig selv. (D)

'Jon said that he never would allow his daughter so much as to consider to marry herself to a man completely different from ____.'

First, note that SIG seems to be excluded in all of these contexts for most speakers (see 6.2 for discussion) even where pronouns are not. Notice that pronouns coreferent with the matrix subject are excluded with exclusion predicates as in (35c,d), as long

as the subject is in the same clause as the predicate that selects the whole exclusion phrase (*Marie* as opposed to *Carl* as in (35c)). This fact is just as in English. Also, similarity predicates and normal predicates do not exclude coreference between the subject and a similarity predicate object pronoun, just as in English.

Missing in English, however, are the contrasts between the two SELF-forms. The SIG-SELF-form, which is always subject oriented, is excluded with normal postnominal predicates (35a) and with similarity predicates (35b) — it is not logophoric — but it is accepted for exclusion predicates (35c,d), as long as the subject it is related to is the nearest one (compare *Carl* and *Marie* as antecedents in (35c)).¹¹ Pronoun-SELF is acceptable with similarity (35e) and exclusion predicates (35c) whether it is coreferent to the near or the far subject, but pronoun-SELF is not acceptable with normal (e.g., emotive) predicates as in (35a) either locally or long distance. Once again, the R&R approach provides no account of why pronoun-SELF is sensitive to the meaning of the predicate it is embedded in.^{12,13}

Following the same sort of reasoning for SIG-SELF-forms as R&R assume for Principle B, the exclusion predicates in (35c,d) require for SIG-SELF the same analysis suggested for exclusion predicates with respect to pronouns (which determines that pronouns are excluded) as provided for (5a) in (5b) mentioned earlier (see also fn.8).

(36) John (lx (x hates everybody & NOT (x hates x)))

The grammaticality of SIG-SELF in these environments is further evidence for semantic Principle A, since SIG-SELF should be excluded if it is only evaluated in syntax.

¹¹ Danish informants prefer that *sig selv* not have a plural antecedent in which case the pronoun-SELF form is used. In other words, SIG-SELF may be specified as singular in Danish, but not in Norwegian or Swedish.

(i) [Jon og Per], fortalte Sofie om dem selv/*sig selv. (D)
'Jon and Per told Sofie about ____.'

¹² Comparatives are also predicates that induce logophoric behavior of pronoun-SELF, but they involve complications I have chosen to avoid here (see Safir 1992: fns. 15 and 21).

¹³ A Dutch reviewer points out that many of the facts in MS discussed here are largely similar to those of Dutch. However pronoun-SELF is not anti-subject oriented in Dutch and it thus overlaps with the local domain of *zichzelf*, which is subject oriented. I will not explore this very interesting data for reasons of space, but see Koster (1984:155-163) for a pioneering discussion of pronoun-SELF/SIG-SELF contrasts in Dutch.

However we are now faced with a problem: If we account for the viability of SIG-SELF in an exclusion predicate by means of a parallel conjunct analysis, the same analysis that is required to rule out pronouns in the same position, then it is not clear why pronoun-SELF is grammatical in this position.

Clearly the R&R system is out of its depth in these questions, partly because it cannot make the right predictions in its current formulation, and partly because the distinctions between pronoun-SELF and SIG-SELF happened not to be among those R&R designed their theory to address. A more comprehensive approach to these questions is thus warranted.

5 Integrating the Principles A and the Principles B

Now it is time to devise a system that makes some of the distinctions and captures some of the generalizations that are missed in the R&R approach. I shall make use of the following leading ideas.

- I The semantic domains for Principles A and B are identical, based on the notion of reflexive predication.
- II The syntactic domains for Principles A and B are identical and built on a 'functional complex' notion.
- III Anaphors with defective contextual possibilities for antecedency may be logophors.
- IV The Principles A differ from the Principles B in that only the former apply wherever possible to license an anaphor.
- V The principles A jointly compute the potential for logophoricity.

I and II add symmetry to the R&R system, which had two Bs but only one A. In this section I will focus on fleshing out my approach to III-V. Notice that III. is close in spirit to the R&R method of identifying logophors, but as we shall see, it will be executed here in a more nuanced way.

To see how this system is to work, let us return for a moment to the status of SIG-SELF as it relates to Principle A in syntax. As we saw above for exclusion predicates, SIG-SELF only succeeds at the semantic level where reflexivity is evaluated.¹⁴ SIG-SELF fails at the syntactic level if it is bound outside the exclusion

¹⁴ The assumption that semantic A applies to semantic predicates rather than strict C-command relations makes it possible to remove thematic relations from syntactic A and from the notion of

predicate. In (37), for example, it is bound by *disse fyrene her* and so fails to satisfy syntactic Principle A, where *hvem* ('whoever') (or its trace) counts as the syntactic external argument that Principle A is sensitive to.¹⁵

- (37) Disse fyrene her vil stole på hvem som helst bortsett fra
 *dem/dem selv/*seg/ seg selv. (N)
 'These here guys will trust anyone(whoever) apart from __.'

However, the main two pieces of evidence put forth by R&R to show that SELF-forms fall under syntactic A are that SELF-forms are bound by non-coarguments in raising contexts and ECM contexts, as illustrated for SIG-SELF in (38a) and (38b/c), respectively.

- (38) a Jon forekom ??sig/sig selv/*ham/*ham selv at være den bedste kandidat(D)
 'Jon seemed to himself to be the best candidate.'
 b Jon hoerte sig selv blive kritisert. (D)
 'Peter heard himself be criticised.'
 c Jon hoerte seg selv bli omtalt (N) (Hellan (1988:123)
 'Jon heard himself be mentioned'

At the semantic level, *Jon* is not a coargument with its antecedent in any of the examples. Thus it would appear that only syntactic A correctly evaluates these cases, creating an apparent paradox.

That the paradox is only apparent may be seen if we adapt the proposition that anaphors, unlike pronouns, need antecedents, and that the principles A are licensing conditions (as suggested by Belletti and Rizzi (1988), though I do not assume their analysis). Both semantic principle A and syntactic A license both a bound

syntactic argumenthood. Semantic A now accounts for cases where the antecedent of a reflexive is embedded in a PP thematically selected by the same predicate (see, e.g. Pollard and Sag (1992) and Williams (1995)). Examples where the SELF form is Nominative seem to be excluded independently (see for example, Everaert (1990)), which eliminates *Himself hit himself/him/John*, though the latter two are also excluded under coindexing by the principles B and semantic A, respectively. The ban on Nominative SELF forms, whatever its origin, prevents logophoric licensing for *Himself laughed*. Thus semantic A and B need not state a subject/object asymmetry.

¹⁵ SIG-SELF is ungrammatical in a Danish translation of (37) as per fn. 11. The pattern is otherwise as expected.

(i) De her fyre vil stole på hvem som helst borsat fra *dem/?dem selv/*sig/*sig selv.

interpretation and the element that marks it. Thus if one of the principles A license antecedenthood for an anaphor alpha at any point in the derivation then alpha is well-formed. I assume that syntactic A has the same domain as syntactic B, except that syntactic A simply leaves the anaphor without an interpretation if it cannot apply because no antecedent is available.¹⁶ An uninterpreted anaphor will typically fail any sort of semantic coherence principle.¹⁷

- (39) Syntactic Principle A: an anaphor A is interpreted as bound within the maximal projection of the minimal functional complex containing A.

The requirement that anaphors must have an antecedent, even a discourse antecedent, to be interpretable does not hold of pronouns in the same sense, hence the origin of the asymmetry between Principles A and Principles B, insofar as there is one. (One can walk in on a discourse where someone is saying "He's intelligent, but stubborn" and accept that sentence as grammatical referring to an as yet unidentified individual who is both intelligent and stubborn, but "She considers himself intelligent but stubborn" does not permit such a provisional discourse representation because the anaphor is not licensed for a discourse antecedent.) Accordingly, the Principles B are not about licensing, but rather a form of air traffic control; A bound interpretation of a pronoun is ruled out at any point in a derivation where it has an antecedent too close, i.e., where one of the Principles B is violated.

With these formulations in mind, let us consider the relevant cases more carefully. Note that SIG-SELF is grammatical in raising and ECM contexts because it can

¹⁶ I assume the VP internal subject hypothesis which will insure that if there is an external argument, it will be a potential antecedent (usually in the form of a trace) within the domain of the verb, whether the verb or adjective is simple transitive, ECM or raising. If ECM subjects raise to get Case in AgrO at LF, as in Chomsky (1995), the minimal functional complex containing the anaphor will be that of the matrix V, though not if pronoun-SELF is Nominative. I presume that PPs either form their own domains or not according to the usual thematic or government distinctions (see, for example, Hestvik (1991)). This formulation will serve for presentation, but it does not address the i-within-i cases of Chomsky (1981), which I set aside here. See Safir (1996), for evidence that relational anaphoric atoms are sensitive to the generalization captured by the older formulation.

¹⁷ This could be executed in a variety of ways, but the intention is that any element not assigned an interpretation after semantic principles have applied will constitute a violation. This is the essence of "full interpretation", but that may be too general for this case, which has more the flavor of a θ -Criterion violation, since a thematic argument is represented by a reflexive that cannot be interpreted (compare *John behaved himself*, which, whatever licenses it, does not involve a semantically transitive predicate).

satisfy syntactic Principle A, even though it cannot satisfy semantic A. If SIG-SELF is not coindexed with the raising subject, then it cannot satisfy either syntactic or semantic A, and is hence excluded. Similarly, if SIG-SELF as an ECM subject is not bound in syntax, then it cannot be bound at the semantic level since it will not have any possible antecedent. However, SIG-SELF may fail to meet syntactic A, but still satisfy semantic A, as in the exclusion predicate cases, just in case the antecedent is in a reflexive relation at the semantic level.

Recall now the situation in exclusion predicates, where SIG-SELF fails to meet syntactic A but succeeds in satisfying semantic A when its parallel conjunct antecedent is close enough. Since finding an antecedent at either level is sufficient, SIG-SELF is grammatical in (35c) with *Marie* as its antecedent, but not where *Carl* is, since in the latter case its antecedent is not local even assuming a parallel conjunct interpretation.

5.1 Licensing logophoricity

Remaining now is the distinction between SIG-SELF and pronoun-SELF with respect to long distance possibilities. The essential line I will take here is that both pronoun-SELF and SIG-SELF are potential logophors in the contexts where pronoun-SELF acts as a logophor, but that SIG-SELF is disqualified as a logophor because it contains SIG, which, as R&R among others have discussed, lacks syntactic phi-features by comparison with pronouns. As a result, SIG is inherently syntactically dependent in a way that pronouns and even pronoun-SELF are not.¹⁸ Thus only pronoun-SELF, and not SIG-SELF, has the potential to be logophoric, even in contexts where anaphors are otherwise licensed to be anteceded logophorically.¹⁹

That SIG-SELF is disqualified as a logophor might as easily be said in R&R's theory, but in their account, SIG-SELF would have to be logophoric in distributed conjunction and exclusion contexts where it is acceptable, which, as we have seen,

¹⁸ I have argued elsewhere that SIG is not regulated by Principle A because it is not a relational atom, unlike SELF, which participates in conventionalized body part metonymy. See Safir (1996) for details.

¹⁹ The proposed differences between SIG-SELF, SIG and pronoun-SELF thus reduce to lexical properties consistent with the Universalist Lexicon proposed in Safir (1996), where it is argued that all anaphora-specific statements are universal. SIG is not an anaphor in this sense. See fn. 18. The potential logophoric status for pronoun-SELF appears inconsistent with any general claim that complex forms must be locally bound (e.g., compare Pica (1989)).

leads to the wrong results (SIG-SELF must still be bound locally at the semantic level).

Now we must provide a system to predict the logophoric distribution of pronoun-SELF. Consider, once again, the exclusion predicate context. In syntax, pronoun-SELF is contained in the domain of the exclusion phrase, where the exclusion predicate modifies a nominal that counts as the external argument of the exclusion predicate. In these contexts, the object of the exclusion predicate could possibly be coindexed with the external argument of that predicate (e.g. *x* excludes *x*), but the sentence would be uninterpretable for semantic reasons. If the object is coindexed with the matrix subject, however, then, under the parallel conjunct analysis, pronoun-SELF should not be possible either, since pronoun-SELF in MS is supposed to be anti-subject oriented. Yet pronoun-SELF is well-formed. I contend (as a statement of fact) that pronoun-SELF is logophoric in every environment where it is not anti-subject oriented. But what mechanism renders pronoun-SELF logophoric in this context?

Suppose anaphors are treated as logophors wherever the normal prospects for antecedency are blocked or inconsistent in some way. The idea may be executed in the following fashion.

- (40) An anaphor α may be interpreted as logophoric unless
- a α has a potential antecedent X in syntax; and
 - b there is no potential antecedent Y at the semantic level for α such that X is indistinct from Y.

Suppose we take "potential antecedent" here to mean the minimal external argument of the domain, which in syntax is the first functional complex (e.g., APs and VPs as well as exclusion predicate environments) containing the anaphor alpha and in semantics is the external coargument of alpha. The prediction is that an anaphor alpha is logophoric if either:

- (41) a it has no external argument at any level (40a); or
- b it has an external argument at the semantic level distinct from the one it has in syntax (40b).

To see how this works, consider how it would apply to pronoun-SELF in English. In a simple sentence like (42a), the first subject within the functional complex containing *himself* is *Perry* and in semantics the external coargument of *himself* is *Perry* so

himself has a "consistent potential antecedent", that is, the potential antecedent in syntax is indistinct from the potential antecedent in semantics.

- (42) a Orin said Perry praised himself.
 b Carol appears to herself to be intelligent.
 c Carol considers herself to be intelligent.

In the case of raising and ECM contexts, as in (42b) and (42c), the syntactic external argument *Carol* is not a semantic non-coargument of *herself* but since *herself* has no potential antecedent in semantics, the potential antecedent in semantics is indistinct from the one in syntax. Thus in all three cases in (42), the reflexive is not logophoric, therefore must receive an antecedent to be well-formed.

By comparison, consider the exclusion context in (43).

- (43) Terance trusts no one other than himself.

In (43) the potential antecedent in syntax is the modified head of the construction, *no one*. However the semantic antecedent, by hypothesis, is *Terance* which is distinct from *no one*, hence *himself* may be logophoric. Now consider the same context in MS, where either pronoun-SELF or SIG-SELF may be employed, as in (37), repeated below.

- (37) Disse fyrene her vil stole på hvem som helst bortsett fra *dem/dem
 selv/*seg/ seg selv. (N)
 'These here guys will trust anyone (whoever) apart from ____.'

Once again the syntactic antecedent, *hvem*, is distinct from the semantic antecedent, *disse fyrene her*, with the result that both anaphors may be logophoric. Indeed pronoun-SELF is logophoric here and is thereby licensed. However SIG-SELF is inherently non-logophoric, so it is only acceptable if it finds an antecedent somewhere in the derivation. If it is coindexed with the syntactic antecedent (*hvem*), the sentence fails a semantic entailment — one cannot be a member of the set that excludes oneself. However if SIG-SELF is bound by its semantic level antecedent, then it can still act as an anaphor. If the semantic antecedent is not the antecedent of SIG-SELF, as is the case if SIG-SELF is not coindexed with *disse fyrene her*, then once again the sentence fails, since SIG-SELF inherently fails as a logophor (notice (40) is a

necessary, not a sufficient condition, for a relational anaphor to be a potential logophor).

In the context of conjunctions, the results for the distributed reading are exactly as one would expect on the parallel with exclusion predicates. The fact that SIG-SELF is required under the distributed reading (see (19b)) suggests subject orientation is relevant to excluding pronoun-SELF under the distributed reading (see 6.2). The collective reading (see (19a)) for which pronoun-SELF is (weakly) licensed is one where the conjunction is a functional complex and no conjunct acts as an external argument for any of the others. Thus pronoun-SELF has no antecedent in syntax or semantics, which predicts that it may be interpreted logophorically. In English this is robustly true for the collective interpretation of (44).²⁰

(44) John talked about Lea and him/himself (as a couple).

Similarly, in picture nominals like that in (45), there is no antecedent at either level. Thus only a logophoric connection should be possible between antecedent and anaphor. Since SIG-SELF is inherently non-logophoric, it is correctly excluded in (45) while pronoun-SELF is correctly licensed.²¹ A very similar exclusion predicate example is provided for contrast in (46), where SIG-SELF is licensed in semantics and pronoun-SELF is licensed as a logophor.

(45) Mary_i fortalte mennene om noen bilder av henne/henne selv/*seg selv_i. (N)
'Mary told the men about some pictures of ____.'

(46) Marie_i vil ikke fortelle Peter om andre enn *henne/henne selv/seg selv_i.(N)
'Marie will not tell Peter about others than ____.'

The leading ideas in I-V are now fleshed out in a system that has appealing independently motivated symmetries, notably the addition of semantic Principle A

²⁰ The fact that pronoun-SELF is at best marginal for many speakers in MS in these more local environments (see (19a)) is probably due to the fact that SIG-SELF and pronoun both crucially disambiguate interpretations, but in English only the pronoun does. This analysis is another departure from Safir (1992), where conjunctions are treated as exclusion predicates.

²¹ If syntactic A is formulated to allow *Mary* to count as the antecedent of the reflexive, which is not assumed here, then it is predicted that SIG-SELF would be licensed in syntax by syntactic A. However it is not clear if permeability of DP to binding from outside is a possibility or not. Hestvik (1991:486-488, ex. (72a,b)) reports intuitions inconsistent with those in (45), and if his interpretation of these data is right, picture nominal contexts have the same status as the raising and ECM cases.

parallel to semantic Principle B, and the complementarity between reflexives and pronouns in semantics and between reflexives and pronouns syntax, except where the inherent differences between anaphors and pronouns intervene. Logophoric behavior of anaphors is a subcase of this latter asymmetry.²² The semantic level in question, the level at which predicates in conjunction and exclusion contexts are reflexive, remains unexplored, as in R&R's theory, but the more nuanced account of contexts inducing logophoric behavior of anaphors receives a systematic reckoning empirically superior to that of R&R.

6 Residual issues

The system just described now accounts for almost all the cases raised as problematic for the R&R approach, but at least two sorts of empirical issues remain: the behavior of pronoun-SELF in similarity predicates and properties of (anti-)subject orientation. Both of these phenomena raise questions about the approach just proposed, though both phenomena are problematic for every other current approach as well.

6.1 Similarity predicate contexts revisited

Let us return to the distinction between regular adjectival predicates, such as *proud* and similarity predicates, such as *similar*. For a regular predicate, the syntactic potential antecedent of the object of the construction is the same as the semantic one. For example in *Purdy loves someone proud of him/*himself*, the syntactic potential antecedent and the semantic one are one and the same: *someone*. The reflexive is only

²² Examples of logophoric reflexives other than those found in picture nominals or uninformative environments (conjunctions and exclusion, similarity and comparative predicates) are both the minority and are notably less acceptable, stylistically marked or archaic-sounding. In the spirit of Pollard and Sag (1992: 278-279), I maintain that many examples of logophorically bound reflexives drawn from literary contexts bring the reader's attention to the language by overtaxing the limits of acceptability in the spoken idiom. These "residue" environments where logophoric reflexives are licensed are a real phenomenon, certainly, but one with a different, more marginal, pragmatic status than the cases mentioned here, which are almost always uncontroversially acceptable and are directly induced by lexical semantic argument structure interacting with syntax. However, the residue cases may be plausibly handled in the licensing account offered here if some sort of stylistic discourse licensing is permitted in this register in addition to anaphoric licensing by the principles A and logophoric licensing by (49).

grammatical if *someone* is its antecedent, not *Purdy*, and the reverse for the pronoun *him*.

In fact, unless more is said, the adjective *similar* should receive the same analysis as *proud* and nothing should license even pronoun-SELF in similarity contexts in both English and MS. Given the consistent potential antecedent framework outlined in section 5, a distinction between *proud* and *similar* must be made such that the object of *similar* (but not *proud*) does not have the same potential antecedent in semantics as it does in syntax.

It would be tempting to state that the similarity predicates are all semantically irreflexive, in effect banning the coargument of the object of a similarity predicate from counting as a potential antecedent at the semantic level. If so, the semantic antecedent would be necessarily distinct from the syntactic antecedent (not, however, non-existent, or it would be indistinct).

The latter line of argument might exploit the fact that (47a-c) all have an odd tautological or contradictory flavor.

- (47) a Sam is similar to himself.
 b Eunice is (un)like herself.
 c Daffy is different from himself.

For predicates like *unlike*, (47b) has an idiomatic reading (not available for *different from*) which has the sense that Eunice is not acting the way she normally does, but aside from the idiomatic reading, the behavior of similarity predicates is consistent. In Safir (1992) I argued that similarity predicates, as opposed to, for example, emotive predicates (*angry at*, *proud of*, etc.), imply non-coreference with the element they are in relation with. For this reason, the local subject or external argument is disqualified, at least with respect to reflexives, as an antecedent.

However the force of the irreflexivity intuition is that of conversational implicature, defeasible in specific contexts where apparently tautological or contradictory statements may be taken literally in an informative way. In most conversational contexts, "x is identical to x" would be taken to be a tautology or else, if negated, a contradiction. Arguably, neither a tautology nor a contradiction is normally informative. However, a statement such as *Every number is identical to itself* may be informative if one were proposing how a particular mathematical system might be axiomatized.

Thus it cannot be said that similarity predicates are semantically irreflexive, though they may typically be pragmatically so. Semantic principle A, if it is to apply

to the object of a similarity predicate in a way that will render pronoun-SELF an anaphor, must, however, treat similarity predicates as "plausibly irreflexive" at the semantic level, hence rendering a logophoric interpretation possible for pronoun-SELF in English and MS. Of course in MS, SIG-SELF is intrinsically precluded from being a logophor, so it will always be excluded in similarity predicates (unless, of course, SIG-SELF is coreferent with the head of the similarity phrase in a potentially informative context, such as the mathematical one).

As discussed in Safir (1992), the class of predicates which are susceptible to this treatment is highly proscribed and requires no real world information to be identifiable — all the predicates in question are those that have no specific thematic content (e.g., agent-patient, or experiencer-goal asymmetries in the argument roles) and involve identity relations such that coreference induces an uninformative interpretation within the bounds of conversational implicature.²³

Notice this account correctly predicts that pronouns will not be ruled out by Principle B with respect to the matrix antecedent in examples like (34a) and (35b). This is the case because pronouns violate syntactic principle B in similarity contexts if the pronoun is coindexed with its similarity phrase coargument, which is external.

It remains unclear exactly what the relations are between irreflexivity induced by semantic content and conversational implicature, on the one hand, and irreflexivity at the semantic level, on the other. Yet this approach appears to be an improvement over the only other discussion of these logophoric effects for similarity predicates, that of Safir (1992), in that the pragmatic effect is not directly intervening in syntax.

6.2 (Anti-)subject orientation

In the account so far I have made no commitment about (anti-)subject orientation except to the generalization that pronoun-SELF is logophoric when it is not anti-subject oriented. The leading hypothesis concerning the aetiology of subject orientation is that anaphors and perhaps pronouns move in LF to positions where the only structural local antecedent available is the subject of the sentence. A variety of proposals along these lines have been made, most notably Pica (1987), Chomsky (1986a), Battistella (1989), Cole et al. (1990) and most pertinently here, Hestvik (1992), which concerns anti-subject orientation in MS as well as subject orientation.

²³ The theory presented here differs, however, from the one presented in Safir (1992) because exclusion predicates are treated here according to the parallel conjunct analysis proposed by R&R (1991), and not as phrases with uninformative interpretations.

These proposals require an identification of the semantic level referred to throughout this paper with the formal syntactic level of LF. As mentioned earlier, SIG simpliciter is ungrammatical in every similarity predicate and exclusion predicate environment. This would not be surprising if these environments were syntactic islands, as they are in English.

- (48) a ?*Which football player did Pete meet someone similar to?
 b *Which movie star would Margo go out with anyone like?
 c *Which politician might Horst trust someone other than?

The failure of SIG then could be attributed to the failure of extraction and, if SIG of SIG-SELF must be extracted, then SIG-SELF will be excluded in all of these environments for the same reason. Paradoxically, however, extraction from exclusion predicates at the semantic level must be allowed if exclusion predicates are to permit SIG-SELF where the antecedent is a semantic coargument (e.g., 35c,d) and not in other contexts.²⁴

Alternatively, one could set aside the general exclusion of SIG and argue, along the lines of Hestvik, that (anti-)subject orientation arises from LF movement of pronouns and SIG to positions where their only potential local antecedents are subjects. Under this approach, it is necessary to take seriously the semantic representations like (33) and treat them as LF-syntactic ones, where movement then takes place within one of the parallel conjuncts. Issues concerning the syntactic representation of modification relations then arise more saliently (e.g. it is necessary to explain why *no politician other than himself* implies that the anaphoric antecedent is also a politician). Moreover, some calculation is then still necessary to determine when pronoun-SELF can be logophoric, and then it still must be explained why it loses anti-subject orientation.²⁵

²⁴ Another reason to doubt the movement account of *sig* is pointed out by a reviewer, who notes that Dutch *zich* can be the object of a pronoun even though preposition stranding of the relevant sort is not allowed generally.

²⁵ Pronoun-SELF, where logophoric, is not required to have a subject antecedent either, as in (i).

- (i) ?Sofie forsikrede Per, at Marie ikke ville fortælle andre end ham selv, om problemerne på universitetet. (D)
 Sofie forsikret Per, at Marie ikke ville fortælle andre end ham selv, om problemerne på universitetet. (N)
 Sofie assured Per that Marie not would tell other than himself about problems-the at university-the

More specific to the minimalist framework of Chomsky (1993, 1995), it is also necessary to show that the agreement related to subjects is the natural target of movement to satisfy anaphora constraints. If there is an AGR-O node in a language, there is nothing fully natural about the apparent reliance on subject antecedency, and this is more acute in the standard MS languages, which lack overt agreement altogether (cf. Holmberg and Platzack (1995), for a recent account) but permit overt pronominal object-shift (e.g., Holmberg (1986)). Moreover, given the atomization and extension of functional projections within clausal structure, a variety of landing sites with different consequences for antecedency must be explored, especially as the range of possible functional projections assumed is not currently standardized.

While I do not consider such impediments for the SIG-movement approach insurmountable, I do consider them beyond the scope of this paper, and so I will set all issues involving (anti-)subject orientation aside.²⁶ However the issue of whether the semantic level where the parallel conjunct analysis holds is in fact a level of LF may largely be decided on this question. The issue is far from trivial, because if the semantic level is LF, then there is no natural candidate for the so-called syntactic level without reproducing the S-structure level that minimalist theory has discarded. If the syntactic level is LF, however, as I assume for concreteness here, then the semantic level in question is some post-LF representation where exclusion predicates are interpreted (see also Culicover and Jackendoff (1995) where similar issues are raised).

7 Unification

The central line of argument has been to establish a symmetric theory of the principles regulating anaphora, such that syntactic and semantic principles regulate both pronouns and anaphors. The symmetry extends to the domains of the two syntactic principles and the domains of the two semantic principles, returning, in doubled form, to earlier notions of A/B symmetry (i.e., the conflation of A and B domains in Chomsky (1991)). However there is a major asymmetry in the way these principles treat anaphors as opposed to pronouns. Only anaphors require antecedents

²⁶ I have not tied my account of the logophoricity for pronoun-SELF in MS to its anti-subject orientation, since in English, as in Dutch, pronoun-SELF is not anti-subject oriented and yet behaves logophorically. Recall that the lack of anti-subject orientation for MS pronoun-SELF is used merely in a diagnostic way that allows us to see distinctions not as easily seen, if seen at all, in Dutch and English.

and hence must be licensed at some point in the derivation, either as anaphors or as logophors, depending on what sorts of potential antecedents the anaphor in question has contextually, or what sort of antecedent that anaphor may have intrinsically. By contrast, pronouns must avoid prohibitions at any point in the derivation.

One reason scientists pursue symmetry is that truly symmetric principles often turn out to be matching halves of the same bean. Suppose, for example, that semantic principles A and B are minimal revisions of (2a,b), except that both now hold at the semantic level.

- (49) a Semantic A: a reflexive-marked predicate is reflexive.
 b Semantic B: a reflexive predicate is reflexive-marked.

Notice that the conditions that determine when anaphors are potential logophors in (40) do not refer directly to the Principles A. If semantic Principle A, like syntactic A, functions as a licenser of anaphors and reflexive interpretations, with the residue either logophoric or excluded, then it becomes possible to unify (49a,b) as in (50), which applies, of course, at the relevant semantic level.

- (50) **Reflexive interpretation**
 A predicate is reflexive if and only if it is reflexive-marked

Reflexive Interpretation formulated this way both licenses SELF-forms that contribute to reflexive marking, while excluding interpretations with which it is not compatible. I assume here that reflexive marking is optionally checked off or cancelled by binding under syntactic A, hence *John hates himself* could be licensed by syntactic A but ruled out by (50), since at the semantic level, *John hates himself* is no longer reflexive marked. For such sentences to be acceptable, the SELF-form must be licensed by semantic A only, which is possible since syntactic A only applies optionally to license SELF-forms where it can. In this way, ECM cases such as *John considers himself to be smart* are possible because application of syntactic A in these cases removes the reflexive marking that would otherwise render *himself to be smart* deviant by (50). In general the rule of reflexive interpretation excludes predicates that have no reflexive reading because they only involve one argument, e.g., **There exists*

himself or *Himself died*. In such cases, unless reflexive marking is erased by syntactic Principle A, (as it can be in ECM contexts), the result is starred.²⁷

In effect, syntactic A licenses SELF-forms as bound elements rather than as reflexive predicate formers. While syntactic B permits SIG, which participates in bound interpretations and is not reflexive, syntactic A gracefully licenses the overlap in distribution between SIG and SIG-SELF in certain environments (e.g., see Hellan (1988: 122-126)). Though the right theory of SIG remains an open question at this point, questions about its distribution are now sharpened.

Thus in the end, the addition of semantic A merely reveals the true nature of semantic B - they are the same principle.

It is important to understand that the account of reflexive interpretation in (50) implies that bound readings and reflexive ones never overlap - they are in complementary distribution. This proposal is at odds with unstated assumptions of the reflexivity theory (where both syntactic and semantic conditions refer to reflexivity), but some interesting evidence suggests it may be correct. Consider (51).

- (51) a Everyone hates Max.
 b John hates him, Bill hates him...
 c Even Max hates him.
 d #Even Max hates himself.

This sort of paradigm, brought to my attention by Arild Hestvik (personal communication), is used to illustrate the difference between accidental readings, readings where the subject and object bear different indices, but are nonetheless interpreted as having the same referent. This is possible for the pronoun in (51c), since it may draw its referent from discourse rather than binding, while (51d) is only interpreted as a reflexive predicate. The latter interpretation arises because reflexive interpretation does not permit (51d) to be interpreted by binding if subject and object are coindexed (by (50) the predicate is reflexive, hence must be reflexive marked).

²⁷ Recall that cases like **Himself hit him* are ruled out by syntactic B, but *Himself hit himself* is not so eliminated. This may be due to the incompatibility of syntactic anaphors with Nominative (see fn. 14) or it may be due to the redundancy of reflexive marking, though the marker on the object may be erased by application of Principle A in syntax.

However (50) predicts the striking contrast between (52d) and (51d).

- (52) a Everyone expects O.J. to be acquitted.
 b Ann expects him to be acquitted. Moe expects him to be acquitted...
 c Even O.J. expects him to be acquitted.
 d Even O.J. expects himself to be acquitted.

The reason the strict interpretation is possible in (52d) is that *even O.J.* binds the SELF- form in syntax, so the SELF-form does not participate in a reflexive interpretation even though it is bound. Hence the contrast with (51d). Evidence such as this demonstrates the difference between reflexivity, on the one hand, and binding (or accidental coreference in the case of (51c) and (52c)), on the other. Both of the latter may be the source of strict readings under the right conditions. More specifically, it demonstrates that syntactic Principle A is not truly about "reflexivity", contra R&R.²⁸

Turning now to the syntactic level, it is also possible to unify syntactic A and B under a single principle restricting locally bound interpretations, as in (53).

(53) **Locally bound interpretation** (applies in syntax)

An element *x* bound within the maximal projection dominating the minimal functional complex containing *x* is not a pronoun²⁹

The checking off or licensing of anaphoric status is a concomittant effect of (53) for those elements that are bound without violating (53) (or Principle C, in the case of names). In this way, (54) can be excluded because *herself* is not identified by (53) (it

²⁸ Further interesting issues, apparently not problematic ones, arise for the strict and sloppy readings available for comparative VP elision in (i).

(i) John hates himself more than Bill does.

The sloppy reading presumably reproduces the interpreted reflexive relation in the elided portion, but the strict reading can only be derived from a representation of the overt portion that precedes reflexive interpretation.

²⁹ In Safir (1996), I argued that Principle A applies only to relational anaphors and not to SIG-forms. In the context of this paper, however, this means that Reflexive Interpretation and (53) do not apply to trace or PRO, a position I will not defend here. However it is plausible to assume that PRO is a pronoun and that the head of the clause that assigns it Null Case is dependent, as in Borer (1989), perhaps even a relational anaphor. It is also plausible that NP-trace falls under Chomsky's (1995) Minimal Link of Chain, and not (53), which, unlike MLC, specifically restricts pronounhood.

is not locally bound, hence identified as non-pronominal/[-R]) nor by (50) (it is not in a reflexive relation expressed by reflexive marking) and it is not licensed to be logophoric, since it has a consistent potential antecedent (namely, *Bill*, by the the condition on logophors in (40)).

(54) *Carol considers Bill to be angry at herself

This result is a natural one from the perspective of the licensing-filtering mechanism proposed for anaphors in section 5 which derives the obligatoriness of antecedenthood for anaphors (as part of Full Interpretation or any other general coherence condition) without stating syntactic and semantic principles A.

Thus by distinguishing representations at two levels, syntax and semantics, by balancing the requirements of A and B at both levels, and by factoring out the antecedency asymmetry induced by the needs of anaphors, a symmetric theory of anaphora is revealed to be feasible. The symmetry of what remains then permits surprising unifications, though a variety of interesting questions remain open.

References

- Baker, Carl L. 1994. Locally free reflexives, contrast, and discourse prominence in British English. Ms. of talk presented at the annual Meeting of the Linguistic Society of America, U. of Texas, Austin.
- Battistella, Ed. 1989. Chinese reflexivization: A movement to INFL approach. *Linguistics* 27. 987-1012.
- Belletti, Adriana & Luigi Rizzi. 1988. Psych verbs and theta theory. *Natural Language and Linguistic Theory* 6.3.
- Borer, Hagit. 1989. Anaphoric Agr. In Osvaldo Jaeggli & Ken Safir (eds) *The null subject parameter*. Dordrecht: Kluwer. 69-109.
- Chomsky, Noam. 1981. *Lectures on government and binding*. Dordrecht: Foris.
- Chomsky, Noam. 1986a. *Knowledge of language*. New York: Praeger.
- Chomsky, Noam. 1986b. *Barriers*. Cambridge, Mass.: MIT Press.
- Chomsky, Noam. 1993. A minimalist program for linguistic theory. In Kenneth Hale & S. Jay Keyser (eds) *The view from building 20*. Cambridge, Mass.: MIT Press. 1-52.
- Chomsky, Noam. 1995. *The minimalist program*. Cambridge, Mass.: MIT Press.
- Claesen, H., S. Eissenbeiss & A. Vainikka. 1994. The seeds of structure. In T. Hoekstra & B. Schwartz (eds) *Language acquisition studies in generative grammar*. Amsterdam/Philadelphia: John Benjamins. 85-118.
- Cole, Peter, Gabriella Hermon, & Li-May Sung. 1990. Principles and parameters of long distance reflexives. *Linguistic Inquiry* 21. 1-22.
- Culicover, Peter & Ray Jackendoff. 1995. *Something else* for the binding theory. *Linguistic Inquiry* 26. 249-275.
- Everaert, Martin. 1990. Nominative anaphors in Icelandic: Morphology or syntax? In Werner Abraham, Wim Kosmeijer & Eric Reuland (eds) *Issues in Germanic Syntax*. Berlin: Mouton-De Gruyter.
- Everaert, Martin. 1991. Contextual determination of the anaphor/pronominal distinction. In Jan Koster & Eric Reuland (eds) *Long distance anaphora*. Cambridge, England: Cambridge University Press. 77-118.
- Grimshaw, Jane. 1990. *Argument structure*. Cambridge, Mass.: MIT Press.
- Hellan, Lars. 1988. *Anaphora in Norwegian and the theory of grammar*. Dordrecht: Foris.
- Hestvik, Arild. 1991. Subjectless binding domains. *Natural Language and Linguistic Theory* 9. 455-496.
- Hestvik, Arild. 1992. LF-movement of pronouns and antisubject orientation. *Linguistic Inquiry* 23. 557-594.
- Holmberg, Anders. 1986. *Word order and syntactic features in the Scandinavian languages and English*. Doctoral dissertation. U. of Stockholm.
- Holmberg, Anders & Christer Platzack. 1995. *The role of inflection in Scandinavian syntax*. Oxford: Oxford University Press.
- Huang, C.-T. James. 1983. A note on the binding theory. *Linguistic Inquiry* 14. 554-561.
- Koster, Jan. 1984. Reflexives in Dutch. In Jacqueline Guéron, Hans-G. Obenauer and Jean-Yves Pollock (eds) *Grammatical representations*. Dordrecht: Foris. 141-167.

- Pica, Pierre. 1987. On the nature of the reflexivization cycle. *The proceedings of NELS 17*. GLSA. U. of Massachusetts, Amherst. 483-499.
- Pica, Pierre. 1989. On the interaction between antecedent-government and binding: The case of long distance reflexivization. In Jan Koster & Eric Reuland (eds) *Long distance anaphora*. Cambridge, England: Cambridge University Press. 119-135.
- Pollard, Carl and Ivan Sag. 1992. Anaphors in English and the scope of Binding Theory. *Linguistic Inquiry* 23. 261-303.
- Reinhart, Tanya and Eric Reuland. 1991. Anaphors and logophors: An argument structure perspective. In Jan Koster & Eric Reuland (eds) *Long distance anaphora*. Cambridge, England: Cambridge U. Press. 283-321.
- Reinhart, Tanya and Eric Reuland. 1993. Reflexivity. *Linguistic Inquiry* 24. 657-720.
- Reuland, Eric and Tanya Reinhart. 1995. Pronouns anaphors and case. In Hubert Haider, Susan Olsen & Sten Vikner *Studies in comparative Germanic syntax*. Dordrecht: Kluwer. 241-268.
- Riad, Tomas. 1988. Reflexivity and predication. *Working Papers in Scandinavian Syntax* 36. Department of Linguistics, Lund.
- Safir, Ken. 1987. The syntactic projection of lexical thematic structure. *Natural Language and Linguistic Theory* 5. 561-601.
- Safir, Ken. 1992. Implied noncoreference and the pattern of anaphora. *Linguistics and Philosophy* 15. 1-52.
- Safir, Ken 1996. Semantic atoms of anaphora. *Natural Language and Linguistic Theory* 14. 545-589.
- Sells, Peter. 1987. Aspects of logophoricity. *Linguistic Inquiry* 18. 445-479.
- Vikner, Sten. 1985. Parameters of binder and of binding category in Danish. *Working Papers in Scandinavian Syntax* 23. Trondheim: University of Trondheim.
- von Stechow, Kai. 1992. Exceptive constructions. *Natural Language Semantics* 1. 123-148.
- Weerman, Fred. 1996. Asymmetries between nominative, accusative and inherent case. *OTS Working Papers in Linguistics*. Utrecht: Research Institute for Language and Speech.
- Williams, Edwin. 1995. *Thematic structure in syntax*. Cambridge, Mass.: MIT Press.
- Zribi-Hertz, Anne. 1989. A-type binding and narrative point of view. *Language* 65. 695-727.

Pronouns and Perspectives

Christopher Tancredi

1 Introduction*

Pronouns present some of the most challenging of problems to theories of syntax and semantics. Our present understanding of pronouns recognizes at least two distinct ways in which they can be interpreted: as bound variables or as simple referring expressions (cf. Sag 1976a, 1976b, Williams 1977). However, it is generally conceded that there are restrictions on pronominal interpretation which cannot be derived from their semantics alone. Thus, conventional accounts of Binding Theory (Chomsky 1981; Fiengo & May 1994; Higginbotham 1983; Lasnik 1981; Reinhart 1983) analyze the distinction between the following two sentences as deriving from syntactic restrictions on the binding of pronouns.

- (1) a John thinks Mary admires him.
b John admires him.

While a bound interpretation of *him* can be generated semantically in both examples, the syntactic binding necessary for producing this interpretation is taken to be possible only in (1a), and not in (1b). This view of pronominal interpretation has gained wide acceptability. In this paper, I will challenge this conventional wisdom by examining in closer detail the interpretational difference between the two sentences in (1). I argue that

* This paper has benefited from discussions with many people as well as from comments on earlier drafts. I wish to thank in particular Jun Abe, Yoshio Endo, Makoto Kanazawa, Noriko Kawasaki, Pierre Pica, Ruth Reeves, Mamoru Saito, Akira Watanabe, Miyuki Yamashina and two anonymous reviewers for their helpful comments. I also wish to thank the audiences at the several places at which parts of this paper were presented, in particular the conference on Atomism and Binding, the 1996 annual meeting of the English Society of Japan, the Sophia University Semantics Workshop, and Nanzan University for helpful comments. Remaining errors are my own.

at least one of the interpretational differences found does not follow from the bound/referential distinction, as it is often mistakenly assumed to.

That conventional analyses are incomplete can be seen from the fact that they provide no clear connection between treatment of a pronoun as a bound variable and construal of that pronoun. The pronoun in (1a) straightforwardly allows for what I refer to as a self-oriented interpretation, while the pronoun in (1b) does not.¹ However, there is nothing inherent in the interpretation of an expression as a bound variable that leads one to predict this distinction, and one needn't look far to find examples of sentences in which such a correlation fails to obtain. Three examples in particular come to mind: bound pronouns in Castañeda sentences (2a) (cf. Higginbotham 1992), explicit use of variables in a mathematical register (2b), and unbound pronouns given a self-oriented interpretation in Represented Speech and Thought (RST) (2c) (cf. Banfield 1978, 1982).

- (2) a Every unfortunate war hero thinks *he* was brave.
 b John is an *x* such that *x* thinks Mary admires *x*.
 c (John frowned.) Now *he* would be all alone again.

(2a) allows for the pronoun *he* to be bound by the quantified expression *every unfortunate war hero* even if each war hero in question is an amnesiac whose sole attribution of bravery is to a character he has read about and who, unbeknownst to him,

¹ I take *self-orientation* to consist in reference to an individual X (conceived of as) made by X via a mental representation of X to which X's own thoughts are attributed. Self-oriented reference can be either direct, as when a speaker employs the pronoun *I*, or attributed, as in certain cases in which a speaker employs the pronoun *he*. In all cases, what makes self-oriented reference possible is the ability of a person to directly access his own thoughts. A pronoun referring to an individual as the person having thought T will refer self-orientedly just in case the reference is grounded from the perspective of the person (represented as) having T. What makes such reference self-oriented is the relation that holds between a person and his thoughts. Unlike identification of an individual as oneself via means used to distinguish other people from one another (e.g. visual resemblance, vocal quality and other sensory based impressions) identifying an individual as the one having one's own thoughts is a type of identification immune to error through misidentification (cf. Evans (1982), especially chapter 7). Having a thought leaves no room for wondering whether that (token) thought is one's own or someone else's, and so referring to the person having that thought similarly leaves no room for wondering whether that person is oneself or someone else. The notion of self-orientation is a notoriously difficult one to define, though I hope the rough ideas sketched in this footnote together with the illustrations in the text will make it possible for the reader to isolate the intended notion.

is that war hero himself. Since *he* on this interpretation does not refer by way of a thought, it is not self-oriented, though it clearly is bound. Similarly, (2b) can be true in a situation in which John fails to realize that it is himself that he thinks Mary admires. On such an interpretation, no occurrence of *x* will refer via a thought, and hence none will be self-oriented, though again the final occurrence of *x* has to be viewed as a bound variable. If a self-oriented interpretation were a consequence of binding a pronoun as a semantic variable, then in both of these examples a self-oriented interpretation would be expected to be obligatory, contrary to fact. Finally, in (2c) the pronoun can be given a self-oriented interpretation despite the fact that there is no potential binder for it. The sentence in this case is typically taken to represent the content of a thought attributed to John, making it possible for the pronoun to refer to John as the person having that thought, yielding self-orientation. These facts illustrate that binding in the sense needed to generate a bound variable interpretation of a pronoun is neither a necessary nor a sufficient condition for generating a self-oriented interpretation. Even if there are good reasons to assume that the binding relation is restricted by the standard Binding Constraints, these data show that those constraints cannot be taken to tell the whole story of how interpretation of pronouns is constrained.

The inability of standard Binding Theory to account for the distinction in self-orientation witnessed in (1) makes it necessary to supply an independent account of how self-orientation comes about. While one could stipulate Self-Orientation Conditions which prohibit self-oriented interpretations of pronouns with local antecedents, parallel to standard Binding Conditions B and C, this would be an unilluminating technical solution to a conceptually highly complex problem, inheriting all of the conceptual shortcomings of standard Binding Theory. In particular, it would rest on an unreducible stipulation of binding/self-orientation domains and their relation to observed interpretational restrictions. The analysis I propose in this paper is intended to overcome these conceptual shortcomings. It is shaped by a guiding view of grammar as consisting of fundamental mechanisms which operate uniformly without negative constraints. I take this view to be the central guiding principle behind the Minimalist Program of Chomsky (1995), though the analysis pursued here is not tied to that or any other particular framework of grammar. To account for the contrast in (1), I show that a self-oriented interpretation can derive from the normal functioning of semantic mechanisms of interpretation applied to pronouns whose lexical content includes a thought. In (1a), these mechanisms will, given the right lexical choice of pronoun, automatically result in the possibility of a self-oriented interpretation for the pronoun. The same mechanisms applied to (1b), in contrast, will fail to generate a self-oriented

interpretation. While the focus of this paper is limited to the question of how to generate and restrict self-orientation, the view of pronominal interpretation which underlies the analysis suggests a different approach to a much wider class of what have heretofore been lumped together under the heading of Binding phenomena, one in which no negative constraints need be stated at all, syntactic or otherwise.

2 Self-orientation

The idea I will pursue here is a familiar one, that self-orientation for third person pronouns is related to self-orientation obtained with first person pronouns (cf. Evans 1982; Kaplan 1977, 1979; Perry 1979; Richard 1983), an idea suggested recently by Abe (1992) and whose origins can be traced back at least to Castañeda (1966, 1967a, 1967b, 1968). I will proceed by examining Kaplan's (1977) analysis of first person reference. I will argue that this analysis, while capable of generating a self-oriented interpretation for first person pronouns, cannot be extended to generate a self-oriented interpretation for third person pronouns. To overcome this problem, I supplement Kaplan's analysis with an independent pragmatic analysis of reference grounding responsible for generating *de re/de dicto* interpretations, and employ this pragmatic analysis as an additional way to generate self-oriented interpretations for pronouns.

2.1 Kaplan (1977) as an analysis of self-orientation²

Kaplan (1977) analyzes first person pronouns as indexical expressions, and proposes that the interpretation of indexical expressions be determined by parameters of what he terms a Context. A first person pronoun's reference is semantically determined via the Agent parameter of the Context in which it occurs.³ Assuming that no non-pronominal expression refers by its semantics via the Agent parameter of a Context, this analysis could potentially form the basis for explaining the contrast in self-orientation of the

² The need to consider the hypothesis that Kaplan's semantics delivers self-orientation without further complication was impressed upon me by Scott Soames (personal communication). For details of the analysis of first person pronouns and its motivation, the reader is referred to Kaplan (1977), especially section XVII.

³ I take the Agent parameter of a Context to identify the individual whose thought is expressed by the expression produced, typically in speaking or writing. This notion of Agent differs from that used by Kaplan in that it refers to thoughts. This difference plays a role in the analysis of self-oriented reference developed below, though it does not affect the arguments of the current section.

subject expressions in the examples in (3) (modeled after similar examples in Perry 1979) by equating self-orientation with semantically determined reference via the Agent parameter of a Context, an analysis Kaplan endorses.⁴

- (3) a I am in pain.
 b He is in pain.
 c Chris Tancredi is in pain.
 d That person (pointing to myself in a mirror) is in pain.
 e The person writing *Pronouns and Perspectives* on August 26, 1995 is in pain.

Amongst these five examples, only (3a) can directly represent a self-oriented thought. This is so even if all the subject expressions are taken to refer to the person denoted by the Agent of the Context (e.g. the speaker, if the sentences are spoken) (cf. Perry 1979). Equating (a pre-theoretical notion of) self-orientation with reference semantically determined via the Agent parameter of a Context would directly explain these facts, since among the five subject expressions only the first person pronoun refers to the Agent by its semantics.

If one looks no further than first person pronouns, the above analysis cannot easily be faulted. However, third person pronouns exhibit a contrast with non-pronominal expressions and with first person pronouns that is parallel to the contrast illustrated in (3) and which cannot be readily explained by Kaplan's analysis. This can be seen most clearly with pronouns occurring in Represented Speech and Thought (RST) environments. Employing this narrative style, we can reconstruct a paradigm parallel to

⁴ That the distinction between *I* in (3a) and the subject expressions in (3b-e) is a distinction in self-orientation is not immediately obvious, especially given the characterization of self-orientation given in footnote 1, since here there is no overt attribution of a thought to an individual. Identifying the distinction as one of self-orientation can be justified, however, when one takes into consideration the fact that utterances typically involve giving expression to a thought. This makes it possible for *I* to refer to the speaker from the speaker's perspective by way of the thought that the speaker gives expression to with his utterance. Since Kaplan makes no use of thoughts in characterizing the intuitively felt distinction between (3a) and (3b-e), in saying that Kaplan equates self-orientation with reference semantically determined via the Agent parameter of a Context, the notion of self-orientation is being given a pre-theoretical interpretation.

that given in (3) above with the roles of first and third person pronouns interchanged as follows.⁵

- (4) a Now he would be all alone, (frowned Chris).
 b Now I would be all alone, (frowned Chris).
 c Now Chris would be all alone, (frowned Chris).
 d Now that guy would be all alone, (frowned Chris).
 e Now the person writing *Pronouns and Perspectives* on August 26, 1995 would be all alone, (frowned Chris).

We see in these examples a difference in self-orientation parallel to that seen earlier in (3) -- only (4a) can directly represent a self-oriented thought of Chris's. Thus in RST environments, third person pronouns contrast with first person pronouns, names, definite descriptions and demonstratives in just the way that first person pronouns contrast with third person pronouns and the others in discourse environments.

In order to maintain that self-oriented reference consists in reference semantically determined via the Agent parameter of a Context, we would have to maintain first that RST occurs in a Context which has an Agent parameter specification, and second that third person pronouns can be semantically determined to refer via this Agent parameter. If we adopted these assumptions, however, then we would have no basis for determining when to employ a first person pronoun and when to use a third person pronoun. To see why, consider the pronouns in the following sentences.

- (5) a i. (A₁) I am in pain.
 ii. (A₁) He is in pain.
 b i. (A₁) Now he was in pain, ((A₂) winced John₁).
 ii. (A₁) Now I was in pain, ((A₂) winced John₁).⁶

By hypothesis, both *I* in (5a-i) and *he* in (5b-i) refer by their semantics via the Agent parameter specifications of their respective Contexts (represented in both cases as A₁),

⁵ The demonstrative pronoun in (4d) cannot be used deictically, setting (4d) apart from its counterpart in (3d).

⁶ Below I assume that there is no independent Agent specification for an RST clause, making the representations in (5b) impossible. I employ these representations here since they are the only representations which could in principle make it possible to reduce self-orientation to reference via the Agent parameter.

the former to the speaker and the latter to John. However, changing the pronouns changes the interpretations of the sentences. In (5a-ii), *he* does not automatically refer to the speaker, nor does the pronoun *I* in (5b-ii) automatically refer to John. If we choose to extend Kaplan's analysis to account for self-orientation of third person pronouns as well as first person pronouns, then some means will have to be devised for differentiating between the referents of first and third person pronouns in these examples.

The obvious place to look for a solution to this problem is to the person features of the pronouns. Two possibilities can be considered for the role that these features play in determining the referent of a self-orientedly interpreted pronoun. First, they can be taken as restrictions on the Agent parameter via which they refer. Agents coming in at least two flavors: first person and third person. Alternatively, they can be taken to restrict the relation between the Agent specification by which reference is determined and some higher Agent specification. Neither analysis, however, is viable.

Consider the first possibility first. In (5a) above, A_1 could be said to be controlled by the speaker (if the sentence is uttered), while in (5b) it is controlled by the third person NP *John*. The choice of pronoun for these two examples could be made by assuming that the pronoun must be identical in person features to the Agent it refers by way of, with number features on Agents restricting their possible controllers. There are two problems with this explanation, however. The first is that it leads to the prediction that pronouns in direct speech environments such as (6) should pattern with those in RST environments, a prediction not borne out.

- (6) a (A_1) John₂ said (A_2) "I am in pain".
 b (A_1) John₂ said (A_2) "He is in pain".

In (6), the embedded Agent parameter A_2 is controlled by the matrix subject *John*, and thus under the hypothesis being considered should bear third person features. Reference via this Agent specification by a pronoun yielding self-orientation should thus only be possible if the pronoun is a third person pronoun, not a first person pronoun, which is patently not the case. The second problem is that the analysis amounts to no more than a stipulation of the facts. Comparing the examples in (5a) with those in (5b) minus the clause in parentheses, the explanation under consideration amounts to the claim that the Agents in the former examples are obligatorily first person while those in the latter are obligatorily third person. This leaves open the question of what could impose these restrictions, and here there are no obvious answers.

The second possible analysis considered, that of taking number features on pronouns to impose a restriction on the relation between the Agent specification via which reference is determined and a higher Agent specification, fares no better, and for the same two reasons. The examples in (5) could all be handled by taking third person self-orientedly interpreted pronouns to require the presence of a higher Agent specification distinct from that by which the pronoun refers. First person pronouns under such an explanation would be the elsewhere case. Alternatively, these examples could be accounted for by taking first person pronouns to refer via the Agent specification of an unembedded Context, with non-first person pronouns being the elsewhere case. Either analysis of the facts in (5), however, leads once again to the prediction that self-oriented reference to *John* in (6) should have to be secured by a third person pronoun, contrary to fact, and furthermore fails to account for the requirement of employing a third person pronoun to obtain self-orientation in RST environments which are not embedded.

The problem of pronoun choice can of course easily be handled by distinguishing first and third person pronouns as Kaplan does, i.e. by only allowing first person pronouns to refer by their semantics via the Agent parameter of a Context. In (5a), only the pronoun *I* in (i), and not the pronoun *He* in (ii), will have an interpretation in which it is semantically determined - in the absence of a particular occasion of use - to refer via the Agent parameter of the Context. The representation of (5b) will have to be changed by eliminating A_1 from the representation, a natural change since the initial clause does not represent the content of an utterance of John's. Making this change results in *I* having to refer by way of A_2 , i.e. to the narrator in its most natural context of use, and eliminates the possibility of *I* referring to John. Finally, we can account for the facts in (6) by taking introduction of A_2 to result in a change of Context and hence a replacement of A_1 . The referent of *I* in (6a) will then have to be secured via A_2 , resulting in *I* referring to John as desired. If we adopt this analysis, however, we are forced to abandon the hypothesis that self-orientation reduces entirely to semantically determined reference via the Agent parameter of a Context, since both first and third person pronouns are equally capable of being given a self-oriented interpretation. This leaves us then in need of an explanation for how self-orientation comes about.

2.2 Refining and supplementing Kaplan's analysis

While Kaplan stipulates a connection between first person reference and self-orientation, he does not specify in what this connection consists. I take it to derive from

differences in one's cognitive representation of oneself and one's representation of others. I analyze self-oriented reference as dependent upon a prior notion of self-representation, taken to be the representation of an individual as having a token thought which is directly accessible to the representing individual. Since the only token thoughts that a person has direct access to are his own, and since the relation of a person to his thoughts is one which is identification free (in the sense of Evans (1982)), representing an individual as having a token thought accessible to the representer amounts to representing oneself in a manner immune to error through misidentification, a manner in principle unavailable for representing other individuals. Self-oriented reference to oneself then consists in reference to an individual as self-represented. Self-oriented reference to another consists in representing the other as an individual having his own self-representation and referring to that represented individual via that self-representation.⁷

Technically, I distinguish two ways that self-oriented reference can be secured. The first is to employ an expression whose interpretation guarantees its represented referent to be a self-representation. This I take to be a property of first person reference, deriving from the Agent parameter which identifies an individual as the one whose thought is being expressed. This is a basic case of self-oriented reference in that it only involves reference of an individual to himself. The second means of securing self-oriented reference is to refer to an individual via a thought of that individual, using the perspective of that individual to secure the reference. This means is the only one that can be employed with (second and) third person pronouns, though I take it to be available for first person pronouns as well. It is a non-basic case of self-oriented reference in that it involves representing an individual as having a self-representation and employing the perspective of the represented individual as referring self-orientedly to himself in addition to employing one's own perspective in identifying who that individual is. Kaplan's analysis of first-person reference covers the first case of self-oriented reference, but as we have already seen it fails to cover the second.

To develop the necessary mechanisms for securing self-oriented reference in the second way, it is necessary to first make explicit several assumptions about the

⁷ In taking self-orientation to be dependent not on reference to real world objects but to mental representations thereof, I am departing strongly from the Fregean and Russellian traditions. Identification of the real world spatio-temporal individual having one's own thoughts is not immune to error through misidentification in the way that identifying the represented individual to whom one's own thoughts are attributed is, and so appeal to thoughts would do nothing to help clarify the nature of self-orientation if reference were taken to be to real world objects.

reference relation. The central assumption implicit in the informal comments given above is that reference consists in associating an extra-linguistic cognitive representation of an individual with the linguistic faculty-internal semantic value of a referential expression.⁸ Within compositional semantics, I take referential expressions to be interpreted either as individual constants (as with names) or as individual variables (as with pronouns and descriptions),⁹ and I take these constants and variables to be entities of a different kind from the (extra-linguistically) represented individuals they are ultimately associated with. Connection of the abstract individual constants and variables of semantics with represented individuals (real or hypothetical) I take to be accomplished at the interface between compositional semantics and reasoning.¹⁰ I refer to the mapping from the former to the latter as a process of grounding reference. Since different individuals have different representations of individuals, the result of reference grounding is of necessity relative to the perspective of the person grounding the reference. This relativity to perspective I take to provide the basis for distinguishing *de re* and *de dicto* interpretations, and is inherent in all forms of reference.

Self-oriented reference differs from other forms of reference in involving an association between a represented individual and an occurrent token thought T of the representing individual's. The association can be direct as in the simplest cases of

⁸ Thus reference as the term is used here is all in the head. Connection to real world individuals comes from the input systems (in the sense of Fodor (1983)) which play a role in forming cognitive representations from sense data.

⁹ I take semantic individual constant denoting terms to be rigid designators in the sense of Kripke (1980). Individual variable denoting terms are capable in principle of being interpreted non-rigidly. This distinction is independent of the process of connecting abstract semantic terms with represented individuals.

¹⁰ The null hypothesis, assumed here, is that this interface level is the level of LF posited within the Extended Standard Theory of syntax. The relation of grounding a reference is similar to Fiengo & May's (1997) notion of an Assignment, though it differs in one important respect. Assignments are for Fiengo and May the type of things that can be believed. Reference grounding, on the other hand, is not, since one of the terms, the LF expression, is embedded in the linguistic faculty, which I take to be inaccessible to the reasoning faculty and hence not a possible component of belief. A man in the street no more believes that a name as represented at LF is mapped onto a particular non-linguistic mental representation of an individual than he believes that a particular trace is governed. A second potential difference lies in the value associated with a particular name. I am explicitly assuming this value to be a (perhaps mentally represented) mental representation of an individual, and not a real world individual. Fiengo & May do not make clear whether they take values to be representations of individuals or real world individuals.

reference to oneself, or attributed as in all cases of self-oriented reference to another. Mere reference to the individual represented as having T, however, is not sufficient for producing a self-oriented interpretation. Rather, in cases of self-oriented reference to another, it is additionally necessary for the reference grounding to be relativized to the perspective of the person who has T. Technically, self-oriented reference results if a semantic individual variable x is mapped to an extra-linguistic representation X of an individual employing X 's (represented) perspective to pick out the person who has thought T, where T is one of X 's own thoughts.¹¹ I illustrate the proposal with the examples in (3a), (4a) and (1a), repeated below with Agents (A), thought tokens (T) and linguistically represented thoughts (t) explicitly represented.¹²

- (7) a (A_1T_1) I am in pain.
 b (A_1T_1) [(T_2) [Now he would be all alone] frowned Chris₂].
 c (A_1T_1) John₂ thinks(t_2) Mary admires him.

In (7a), A_1 is the function associated with the Agent Context Parameter, which maps a semantic individual variable to a represented individual whose thought T_1 is being expressed by the sentence. This represented individual is referred to here and elsewhere as the speaker. The pronoun *I* in (7a), being a first person pronoun, denotes a represented individual via A_1 and hence can be used to refer to the speaker via the mechanisms of indexicality developed by Kaplan (1977). A self-oriented interpretation for the pronoun *I* in (7a) results from the requirement imposed by the Agent parameter that the represented individual have the thought T_1 that the person producing (7a) is giving expression to. Independent grounding of reference for the pronoun via a

¹¹ I use capital letters for extra-linguistically represented individuals and their thoughts, and small letters for syntactic/semantic symbols.

¹² The explicit representation of Agents and thoughts is for expository purposes only. A thought coupled with an Agent, such as (A_1T_1) , is intended to indicate that what follows gives the content of the thought expressed by the speaker. A thought attached to an embedding verb such as "thinks (t_2)" and "said (t_3)" is intended to indicate that one thematic argument of the verb gives the content of a thought which is thematically related to another argument of the verb. Other occurrences of thoughts such as T_2 in (7b) are intended as indicating that what follows gives the content of a thought which is pragmatically attributed to some individual, here Chris₂. Coindexing between Agents, thoughts, names and individual variables is used to make clear who is taken to be the speaker or to whom a particular thought is taken to be attributed. These relations are in all cases independently established, and so the coindexing should not be interpreted as a separate syntactic mechanism.

separate thought, while possible, is not needed for securing a self-oriented interpretation for the first person pronoun.¹³

By hypothesis, the pronoun *he* in (7b) contrasts with *I* in (7a) in that it cannot refer via the Agent Parameter of the Context it occurs in. However, taking the bracketed clause following (T_2) to express the content of a token thought T_2 and analyzing the reference of *he* as grounded to the individual having thought T_3 will give rise to a self-oriented interpretation provided that the person who has T_3 also has T_2 . This will result in the referent of the pronoun being grounded as “the person having thought T_3 ” from the perspective of the person having T_3 . Taking this individual to be Chris gives us an explanation for the fact that the pronoun can refer self-orientedly to Chris. In (7c), the verb *thought*, thematically attributing a token thought to the represented individual J associated with the name *John*, introduces J’s perspective as one to which reference grounding can be relativized. If the referent for the pronoun is grounded as the individual having thought T_3 , where that individual is J, then using J’s perspective to ground the reference of the pronoun to J’s self-representation will give rise to a self-oriented interpretation for that pronoun. The formal task that remains is to give rules for introducing perspectives and to formulate the semantics of pronouns in such a way that these analyses fall out without needing to be stipulated.

2.2.1 Introducing thoughts

I take an individual’s perspective to be available for grounding reference for any expression used to express the content of a token thought of that individual. Thought tokens I take to be introduced in at least three ways. First, I analyze utterances as the direct expression of a token thought of the speaker, with the sentence uttered giving the

¹³ That grounding of reference provides an independent means of securing a self-oriented interpretation for first person pronouns is supported by Lakoff’s (1972) Brigitte Bardot sentences, where a single speaker is associated with two distinct perspectives, a waking perspective and a dream perspective, both of which can be used simultaneously to generate self-oriented interpretations for the italicized first person pronouns in (i).

(i) I dreamed that I was Brigitte Bardot, and (in my dream) *I* kissed *me*.

Allowing attitude attributions to a first person subject to introduce the speaker’s perspective separately from the introduction that comes from the speaker being associated with the Agent context parameter conflicts with Fiengo & May’s (1997) claim that first person belief reports do not contain attributed Assignments. Since that claim does no work for them, I take it to be simply mistaken.

content of that thought.¹⁴ Second, I analyze certain predicates as introducing token thoughts whose contents are given by a designated argument, primary among these being propositional attitude embedding predicates and predicates of communication. Third, I allow thought tokens to be introduced inferentially, as in cases of Free Indirect Speech and Represented Speech and Thought. I assume that every thought token that is introduced must have its bearer identified, and that this can be accomplished in at least three ways. The bearer of a token thought whose content is expressed by a normal assertion (question, etc.) is the represented individual that produced the assertion. The bearer of a token thought introduced by the lexical semantics of a predicate is the represented individual associated with the semantic value of a designated argument of that predicate.¹⁵ Thought tokens introduced inferentially have their bearer identified pragmatically. According to this characterization, the bearer of T_1 in (7a) and (7b) is the speaker, the bearer of T_2 in (7b) is pragmatically determined to be Chris, and the bearer of the thought associated with t_2 in (7c) is John.¹⁶

2.2.2 Self-orientedly interpreted pronouns

We have seen that a self-oriented interpretation is in principle available (though not required) for pronouns, and unavailable for R-expressions of any type. To formalize the semantics of self-orientedly interpretable pronouns, I propose including token thoughts in their interpretation. I analyze such pronouns as DPs headed by a D which contains the ϕ -features and phonological features of the pronoun, with the complement of D consisting of an NP headed by the (phonologically null) element *persp* denoting the relation of an individual x having a token thought t .¹⁷

¹⁴ More precisely, only a certain subclass of utterances can be analyzed in this fashion. In particular, if examples of unembedded RST are uttered, their content should not be identified as giving the thought of the utterer but of the person whose thoughts are being represented.

¹⁵ Quantification on this view is over assignments of a represented individual to a variable.

¹⁶ I take the obligatory nature of this pragmatic connection to stem from the fact that without it the embedding clause and the RST clause would fail to be related.

¹⁷ In more syntactic terminology, *persp* has two θ -roles, one assigned to individuals and the other to thoughts. I identify these θ -roles with parentheses as in *persp*(x_i, t_j), with the specific labels and subscripts used for purely expository purposes. Given that pronouns can be used to refer to inanimate objects (ships often referred to as *she*) as well as to animate beings (including animals referred to as *it*), it follows that not all occurrences of pronouns have the structure given in (8). I assume that pronouns are systematically ambiguous in this respect.

(8) [DP D [NP *persp*]]

The semantics for this expression I model after that of definite descriptions, with D binding the individual denoting thematic role of *persp* (in the sense of Higginbotham (1985)), taken to be the external argument of *persp*. As with definite descriptions, I take this binding to derive an expression with a semantic reference, in this case an abstract semantic individual variable.

By hypothesis, connection between a semantic individual variable contributed by a pronoun and an extra-linguistically represented individual is mediated by two different types of relations. The first is that of the Context parameters Agent, Addressee and Other, which take semantic individual variables as their values and relate these variables to the speaker, addressee of the speaker, or other represented individual, respectively. The second is the pragmatic relation of grounding reference for an expression, which is the identification of a represented individual from someone's perspective based on the content of the NP complement of D. The perspectives to which identification of an individual can be relativized are presumed to be those which give rise to *de re* interpretations (where the relevant perspective is the speaker's) and *de dicto* interpretations (where the relevant perspective is of someone to whom an attitude is overtly attributed in the sentence).¹⁸ Self-orientation in this second case is the result of grounding a reference for the (semantic) thought *t* contained in *persp* relative to the perspective of individual X, where *t* is grounded to a real thought T which is a thought of X's.¹⁹

To illustrate the process of generating a self-orientation interpretation for a third person pronoun, consider the example in (1a), given a more complete representation in (9) below.

(9) (A₁T₁) [IP John thinks(_{t₂}) Mary admires [DP him [NP *persp*(_{x₃},_{t₃})]]]

¹⁸ Terminology is perhaps misleading here. What I refer to here as *de re* interpretation Fiengo & May (1997) refer to as non-*de dicto* interpretation, reserving the notion of *de re* interpretation for names associated with a real world referent.

¹⁹ Note that the grounding has to be to an actual thought, and not merely to a representation of such a thought. The latter option would allow for the possibility of X's mis-associating the represented thought with someone other than X, leading to the unwanted possibility of error through misidentification.

As an assertion by a speaker (= the individual picked out by the Agent Context Parameter A_1), IP^{20} gives the content of a token thought T_1 attributed to the speaker, sufficient for introducing the perspective of the speaker as one to which reference grounding can be relativized. The semantic interpretation j of *John* is associated with a represented individual J . The verb *thinks* requires that J be represented as having a thought T_2 whose content is given by the embedded clause, thereby introducing J 's perspective as one to which reference grounding can be relativized. Within the pronoun, D binds the external θ -role x_3 of *persp* making the DP as a whole refer semantically to an individual. The N *persp* attributes (the semantic token thought) t_3 to (the semantic individual variable) x_3 , and like all NPs [NP *persp*] can be used to ground the reference of the description. This consists of identifying an individual X_3 and a thought T_3 such that X_3 has T_3 . Restrictions imposed by the ϕ -features in D will require that X_3 be consistent with identifying a represented individual of the speaker's as male, and neither the (represented) speaker nor addressee. The intention to co-refer with the matrix subject will require that X_3 be consistent with identifying J , and hence that T_3 be J 's thought. Since there are two perspectives represented, that of the speaker and that of J , grounding of reference can be done relative to either perspective. Using the speaker's perspective to ground the reference will simply result in X_3 being identified with J , making the pronoun no more self-oriented than the name *John*. Employing J 's perspective, in contrast, will result in X_3 being J 's (represented) self-representation S_J , and reference via S_J results in a self-oriented interpretation for *he*. One loose end needs to be tied up to complete the analysis: S_J has to be connected to J so that grounding a reference to the former results in a reference for the speaker to the latter, and not merely in an attributed reference to some individual not represented from the speaker's perspective. The thought T_2 attributed to J by the speaker provides the necessary glue, since all of J 's thoughts, including T_2 , are represented by the speaker as associated by J with S_J . Given (the speaker's knowledge) that no two distinct people can have the same token thought, it follows that J will have to pick out the same individual as S_J .

The analysis just sketched isolates self-orientation as a potential property of pronouns. Self-orientation is not restricted by the person, number or gender features of the pronoun, making it possible to apply the analysis to first, second and third person pronouns alike. The different referential properties of pronouns are attributed to the semantic interpretation of their ϕ -features, located in D . The particular relations

20 Or rather the highest node in the tree, whatever its category is taken to be.

assumed are given in (10), where *X* and *Y* are represented individuals, *X* is a self-representation, and *x* is the semantic individual variable introduced by a first person pronoun.^{21,22}

(10)

person	non-semantic referent determined by ϕ -features
1st	the <i>X</i> associated with <i>x</i> via the Agent Parameter
2nd	the <i>Y</i> addressed by <i>X</i> above
3rd	a represented individual other than <i>X</i> or <i>Y</i> above

There is at least one case in which the analysis as developed so far allows for a self-oriented interpretation of a pronoun where intuitively no such interpretation is available, namely third person pronouns in quotation environments. This case is illustrated in (11a).

- (11) a (A₁T₁) John thinks (t₂) Sue said (A₃t₃) "I hate *him*".
 b (A₁T₁) John thinks (t₂) Sue said (t₃) she hates *him* .

In this example, the pronoun *him* is contained in an expression which identifies the content of a thought attributed to John. If attribution of a thought to John is sufficient for introduction of John's perspective, and if grounding reference can be relativized to any perspective introduced, a *de dicto* interpretation of this pronoun relativized to John's perspective is predicted to be possible in (11a), leading to the incorrect prediction that the pronoun should be able to be given a self-oriented interpretation. (11a) contrasts with (11b) in that the latter allows the predicted self-oriented interpretation. Since it is difficult to see how introduction of John's perspective could be blocked in (11a) and allowed in (11b), I take the problematic assumption to be that reference grounding can be relativized to any perspective introduced. To block the

²¹ I am only considering singular pronouns here. For plural pronouns, the relation between the referent of the determiner and the Agent parameter will presumably have to be based on an inclusion/exclusion relation, *you* for instance including the individual identified by the Addressee parameter and excluding the one identified by the Agent parameter. Addressing complications introduced by plural pronouns here would only detract from the central aim of this paper, and hence they are put aside. Also, though I include second person pronouns in (10), I do so only to complete the paradigm. They will play no role in the discussion that follows.

²² The interpretation of person features given in (10) is intended for both *persp*-based pronouns and others.

undesirable self-oriented interpretation of the pronoun in (11a), I propose to treat attitude attribution as adding a Perspective specification to the Context, where Perspective is a (potentially multi-valued) Context parameter. I assume that the only Context parameters that can be accessed in interpretation are those that are current, and that a direct quote signals a change of all current Context parameter values, changing the Agent specification so that it picks out the individual being quoted and resetting the Perspective parameter to this single individual as well. Such a change will render all Perspectives introduced in the matrix Context unavailable for grounding a *de dicto* interpretation of any expression in the quoted environment in (11a), in essence rendering John's self-representation inaccessible to *him* and thereby making a self-oriented interpretation for *him* impossible.

We are now ready to see how the analysis predicts when a self-oriented interpretation is available for a given occurrence of a pronoun. Consider first the sentence in (5a_{ii}), repeated below.

(5a_{iii}) (A₁T₁) He is in pain.

As observed earlier, in a normal assertion context a self-oriented interpretation for *he* is impossible. The analysis predicts this fact. As a third person pronoun, *he* cannot refer to the self-representation of the speaker (= X in (10)), eliminating the possibility of analyzing (5a_{iii}) as a basic case of self-oriented reference. This leaves as the only other possibility for generating a self-oriented interpretation for *he* analyzing the pronoun as a *persp*-based pronoun, since only then could grounding the reference with respect to a represented perspective pick out a self-representation. However, the only perspective represented in (5a_{ii}) is that of the speaker, and hence this is the only perspective that can be used to ground the reference of the pronoun. Employing this perspective to ground the reference would result in *he* grounded to the self-representation of the speaker, but this is just what is prohibited by the third person φ -features of the pronoun. Since no other analysis will result in a self-oriented interpretation for the pronoun, such an interpretation is correctly predicted to be unavailable.

In (7b), repeated below, there are two thoughts, one (T₂) attributed to *Chris* and the other (T₁) that of the speaker.

(7b) (A₁T₁) [(T₂) [Now he would be all alone] frowned Chris].

Attribution of T_2 to Chris by hypothesis makes Chris's perspective available for grounding the reference of expressions contained in the initial clause. A self-oriented interpretation for a *persp*-based *he* referring to the speaker will be impossible since *he* is required to refer to a represented individual other than the self-representation of the speaker as in (5a.ii) above. However, interpreting *he* as referring to Chris's self-representation satisfies the non-semantic requirements of the pronoun's ϕ -features in (10), since Chris's self-representation is neither the self-representation of the speaker nor the representation of the addressee. The speaker's representation C of Chris is connected to C's self-representation via the thought attributed by the speaker to C, and thus grounding *he* to C's self-representation will give rise to a self-oriented interpretation of *he* referring to C. Since nothing blocks interpreting a *persp*-based *he* in (7b) in this way, we derive the fact that a self-oriented interpretation of *he* referring to Chris in (7b) is possible.

Consider finally the RST sentence that results from replacing the third person pronoun *he* with *I* in (7b), giving (12).

(12) (A₁T₁) [(T₂) [Now I would be all alone] frowned Chris].

The analysis derives, correctly I believe,²³ a self-oriented interpretation of *I* referring to the narrator by the semantics of first person reference developed by Kaplan. *I* cannot be given a self-oriented interpretation referring to Chris, and this fact as well can be explained within the analysis. The only way that such an interpretation could be obtained would be by analyzing *I* as a *persp*-based pronoun and using C's perspective to ground the reference of the pronoun to C's self-representation. However, the semantics of the pronoun would then result in C having to be identified with the speaker's self-representation, and this will be unacceptable on the plausible assumption that names have third person ϕ -features.

²³ Banfield (1978,1982) claims that neither first nor second person pronouns can occur in RST contexts. The claim that the sentence in (12) is acceptable does not necessarily contradict Banfield's claim, however. Banfield restricts her attention to RST as a narrative style in which the identity of the narrator never comes into play. If this is taken to be a defining property of RST, then the conclusion we are drawn to is that there is another style of narration which has many of the formal properties of RST but in which the narrator is taken to play an active role both in the narration and in what is being narrated.

2.2.3 Condition B-like locality effects

The analysis arrived at in the preceding two sections makes it possible for a pronoun to be interpreted as self-oriented with respect to an individual whenever the pronoun is *persp*-based and the reference of the pronoun is grounded via the perspective of the individual referred to by the pronoun. We can define self-orientation with respect to a particular occurrence *o* of an expression as self-oriented reference to the speaker's representation of *o* via a perspective introduced by a thought *t* thematically related to *o*. The absence of a self-oriented interpretation for pronouns with respect to antecedents that are structurally too close to their presumed antecedent can then be derived from the pronouns' being interpreted outside of the scope of *t*. To illustrate, consider the following sentences.

- (13) a John thinks I admire him.
 b John admires his mother.
 c John admires him.
 d John believes him to be intelligent.

A self-oriented interpretation of the pronoun *him* with respect to *John* is clearly possible in (13a) and clearly impossible in (13c,d). Whether such an interpretation is possible for *his* in (13b) is perhaps less clear than with (13a), though I will assume here that it is.²⁴ In the first example, the verb *think* attributes a thought *t* (grounded to T) to *j* (grounded to J), with the content of T given by the embedded CP. A self-oriented interpretation will result if *him* is analyzed as a *persp*-based pronoun whose reference is grounded via a thought of J's from J's perspective. In (13d), the verb *believe* attributes a thought *t* (grounded to T) to *j* (grounded to J), the content of T given by the embedded clause. In this respect, (13d) is parallel to (13a). The absence of a self-oriented interpretation for *him* in (13d), however, can be explained on the assumption that an ECM subject obligatorily raises out of its embedded clause at LF for Case checking (cf. Lasnik & Saito 1991; Lasnik this volume) and is interpreted in the landing site. The reference of the pronoun will then be grounded outside the scope of J's perspective, i.e. outside the syntactic expression which provides the content of the thought T attributed to J. In this circumstance, identifying a thought contained in the

²⁴ For arguments supporting this claim, see section 3.4. The use of a predicate denoting a psychological state of the subject I take to be necessary for generating a self-oriented interpretation for (13b).

pronoun as a thought of J's will not produce a self-oriented interpretation since this will only succeed in picking out the speaker's representation J, and not J's self-representation S_J.

The cases of (13b) and (13c) are a little more subtle since unlike with the verb *believe*, the verb *admire* does not select an argument which gives the content of a thought attributed to its subject. However, the object of *admire* is nonetheless related to a thought in the manner required to generate a self-oriented interpretation according to the analysis given above. Semantically, *admire* can be analyzed as a three place relation between individuals x,y and a thought t, where "x admires y" is equivalent to "x has a thought t, t is an admiration, and the content of t is $\varphi(y)$ for some predicate φ ." The internal argument characterizing the thought introduced by *admire* makes it possible in principle for *t* to be used to introduce the perspective of X (associated with x) and to ground the reference of y or of an expression contained therein relative to X's perspective. The impossibility of a self-oriented interpretation of the pronoun in (13c) thus cannot be explained as a consequence of thematic relations alone. However, the same explanation given for (13d) can be straightforwardly applied to (13c) as well: the need to check case results in the pronoun raising out of the scope of the subject's perspective, leaving behind a purely referential trace which cannot give rise to a self-oriented interpretation.

This leaves (13b) as the final example in need of explanation. If case-checking of the object of *admire* requires that the entire object raise out of a position where it directly contributes to the identification of a thought thematically attributed to the subject, then clearly a self-oriented interpretation for the pronoun in (13b) would be predicted to be unavailable just as it is in (13c) and (13d). If I am correct in taking a self-oriented interpretation for the pronoun in (13b) to be possible, this suggests that only the NP complement of D in the object (or perhaps its head N) is required to be outside of its base-generated position to satisfy the accusative case checking requirements of the verb and object, the remainder of DP potentially remaining below. An analysis in which accusative case-checking is accomplished by LF movement to SpecAgrO in the form of copying plus complementary deletion could generate the needed structures.²⁵

²⁵ This analysis is incompatible with the analysis of Case checking given by Lasnik (this volume). Lasnik argues that movement to SpecAgrO of ECM subjects and direct objects is overt. Since the movement and complementary deletion needed to produce a structure which will allow for a self-oriented interpretation for the pronoun in (13b) results in the N(P) *mother* occupying SpecAgrO and the remainder of the object [_{DP} *his D t*] remaining in the complement position of the verb, on the

2.2.4 Non-self orientation of names

A final question that arises at this point is how to prevent generating a self-oriented interpretation for names. By hypothesis, names can have their reference grounded relative to a perspective, as occurs with typical *de dicto* occurrences. Furthermore, self-representations are in many instances accessible to names. Grounding a reference to such a self-representation, however, would result in a self-oriented interpretation for names, and we have already seen that such an interpretation is lacking. There are at least two ways in which the absence of such an interpretation can be explained. The first is to analyze it as a conventionalized Gricean Quantity-based scalar implicature associated with the use of non-thought based expressions that their thought-based counterparts are inappropriate.²⁶ The second is to appeal to the analysis of names as semantically denoting individual constants rather than individual variables to restrict the representations to which names can have their reference grounded. I take the former approach to be preferable in that it does not involve stipulating restrictions on reference grounding which are otherwise unmotivated. The latter approach, though perhaps empirically adequate, would bring in just the type of negative restriction which I am concerned to try to eliminate from grammar altogether.

3 X-self anaphors

I have so far been considering only simple pronouns. However, complex pronouns as in (14a) also appear to allow for a self-oriented interpretation, and in fact to allow for such an interpretation in positions in which a self-oriented interpretation for simple pronouns is prohibited.

- (14) a Quintus admires himself.
 b Quintus admires him.

assumption that Specs are always to the left of their heads in English this movement will reverse the order between *his* and *mother* from that witnessed and hence cannot be overt.

²⁶ See Horn (1996) for a concise overview of implicatures. The class of Quantity-based scalar implicatures includes that standardly associated with use of a numeral quantifier, *Mary has 3 children* implicating that she does not have four

If nothing special is said about such cases, they stand as potential counterexamples to the analysis developed. Two approaches suggest themselves for dealing with this problem. The first is to argue that appearances in this case are deceptive, the interpretation of locally bound X-self anaphors such as *himself* in (14a) being distinct from the self-oriented interpretation of pronouns we have been considering so far. The second approach is to take initial appearances to be correct and to provide a mechanism whereby X-self anaphors can be interpreted as self-oriented. I argue below for the latter approach.

While the examples in (14) do not alone provide a sufficient basis upon which to argue that X-self anaphors with local antecedents can be given a self-oriented interpretation, it can be shown that there is nonetheless a difference in self-orientation potential between the X-self anaphor in (14a) and the pronoun in (14b). To demonstrate this, I first show how a self-oriented interpretation can be forced upon a particular occurrence of a pronoun in the scope of propositional attitude verbs. I then apply the same procedure as a test for self-oriented interpretation of X-self anaphors.

For pronouns in embedded clauses, a self-oriented interpretation of the pronoun can be forced by the use of *also* to compare two sentences, the second of which contains a pronoun where the first contains a name. An example is given in (15), in which Quintus is taken to be our once amnesic war hero.

- (15) a Before being cured, Quintus thought that Quintus was brave.
 b After being cured, Quintus ALSO thought that HE was brave.

In order for (b) to add something to a discourse consisting of (a) and hence license use of *also* as felicitous, the pronoun in (b) must be interpreted distinctly from the name in (a). Furthermore, the main clause of (b) minus the word *also* must not be entailed by the main clause of (a). Both requirements are satisfied if *he* is interpreted self-orientedly in (b), and they are not satisfied otherwise.

The only two plausible alternative interpretations of the pronoun which could license the use of *also* are as a *de re* expression (with the corresponding occurrence of *Quintus* in the preceding sentence interpreted *de dicto*) or as a bound variable. Neither relation alone, however, licenses the use of *also*. For the first, this can be illustrated based on the Superman story, in which Lois Lane mistakenly thinks that Clark Kent and Superman are two different people, the former a normal human being and the latter a superhuman being capable, among other things, of flying. Within the context of this

story, (16a) is felicitous only as a *de re* statement, while (16b) can be taken either *de re* or *de dicto*.

- (16) a Lois Lane thinks that Clark Kent can fly.
 b Lois Lane thinks that Superman can fly.

Also, however, is not acceptable in the second sentence within the context of the story, i.e. without assuming any change in Lois Lane's mental state from what the context of the story gives us.²⁷

- (17) a Lois Lane thinks that Clark Kent can fly. (*de re*)
 b #Lois Lane ALSO thinks that SUPERMAN can fly. (*de re/de dicto*)

(18) shows that contrasting an explicit bound variable with a name is also insufficient to license the use of *also*.

- (18) a Before being cured, Quintus (was an x such that x) thought that Quintus was brave.
 b #After being cured, Quintus was an x such that x ALSO thought that x was brave.

Since a distinction in self-orientation can license *also* as felicitous in (15b) and all other plausible alternative sources for licensing *also* in (15b) have been eliminated, the use of *also* can be seen as forcing a self-oriented interpretation of the pronoun.

(15) can now be used as the basis for a test for self-orientation: if an expression b can be interpreted self-orientedly and an expression a non-self-orientedly, then a discourse of the form " $f(a)$. *Also* $f(b)$." is predicted to be potentially felicitous even if a and b are intended coreferentially. Conversely, if a and b are intended coreferentially, then a discourse of the form " $f(a)$. *Also* $f(b)$." is predicted to be felicitous only if b can

²⁷ The discourse is felicitous if both *Superman* and *Clark Kent* are taken *de dicto*, though this would involve attributing a belief to Lois Lane that contradicts one of the premises of the story, namely the premise that Lois Lane thinks (*de dicto*) that Clark Kent is a normal person without any supernatural abilities. Note that putting the *de dicto* sentence first followed by the *de re* sentence, with *also* included in the latter, fares no better.

- (i) a Lois Lane thinks that Superman can fly. (*de re/de dicto*)
 b #Lois Lane ALSO thinks that CLARK KENT can fly. (*de re*)

be interpreted self-orientedly and *a* non-self-orientedly. Using a name for *a* then makes it possible to test for the possibility of a self-oriented interpretation for *b* by making *b* coreferent with the name. Applied to (14a), this test shows that a self-oriented interpretation is possible for *himself* in that example.

- (19) a Before being cured, Quintus admired Quintus.
 b After being cured, Quintus ALSO admired HIMSELF.

As seen in (20), however, the possibility of a self-oriented interpretation for *himself* is sensitive to the choice of predicate selecting *himself* as argument.

- (20) a Just before being cured, Quintus was touching against Quintus.
 b #Just after being cured, Quintus was ALSO touching against HIMSELF.

I take the relevant generalization to be that a self-oriented interpretation is possible for an anaphor with respect to a local antecedent only when the predicate that selects it attributes a thought to the antecedent.

The availability of a self-oriented interpretation for *himself* in (19b) contrasts with the unavailability of such an interpretation for the pronoun *him* in (21).²⁸

- (21) a Before being cured, Quintus admired Quintus.
 b #After being cured, Quintus ALSO admired HIM.

The explanation given earlier for the unavailability of a self-oriented interpretation for *him* was that *him* is required to raise outside the scope of the thought introduced by *admire* in order to have its case checked, thereby making it impossible to ground the reference of the pronoun via the perspective of the represented individual denoted by the subject. We can allow for a self-oriented interpretation of the anaphor *himself* in (19b) by assuming that the Case-checking requirements of the verb and object do not force the pronoun *him* contained in *himself* to raise. Analyzing *himself* as having the same basic structure as a possessive construction as in Pica (1987), the analysis of (19b) will then parallel that of (13b) earlier, with the Case-checking requirements of the verb and object satisfied by raising *self* alone. Of course, the need to satisfy Case

²⁸ That there is nothing wrong with the intended coreference between *him* and *Quintus* can be seen by the fact that the sentence *Quintus admired HIM* would be perfectly felicitous as a replacement for *Quintus admired Quintus* in (21a).

requirements does not explain the necessary coreference between subject and object in (19b); clearly *self* must serve some other function as well. Since the focus of this paper is self-oriented interpretation and not simple coreference, however, I leave a detailed analysis of the coreference relation aside.

4 Summary and conclusion

I have argued for the following points in this paper.

- I: Traditional conceptions of Binding Theory as restrictions on identity/dependency of syntactically determined reference fail to account for the distribution of self-oriented interpretation.
- II: Self-orientation is a property restricted to pronouns (including anaphors and presumably PRO), and is not possible for non-pronouns.

In arguing for these points, I have made the following proposal, intended to partially replace Binding Conditions B and C.

- III: Self-orientation consists in grounding reference to a represented individual via a self-representation of that individual, where the reference grounding is from the perspective of the represented individual.

The analysis presented in this paper extends the range of phenomena that can be accounted for beyond the data that have traditionally come under the purview of Binding Theory. In particular it explains the range of construal possibilities for R-expressions and pronouns which lack an overt antecedent, and it explains the possibility of self-orientation for complex anaphors as well as the impossibility of self-orientation for pronouns with respect to local antecedents. It clearly cannot replace standard binding conditions since it does not address the conceptually separate question of how to restrict anaphoric referential relations. However, it does suggest that a rethinking of these conditions is in order along lines which make explicit both what binding conditions are needed to explain and how they interact with other aspects of interpretation to provide this explanation.

References

- Abe, Jun. 1992. The locality of zibun and logophoricity. ms. University of Connecticut, Storrs.
- Banfield, Ann. 1978. Where epistemology, style, and grammar meet literary history: the development of represented speech and thought. *New Literary History* 9. 3. 415-54, reprinted with abridgment in John Lucy (ed.) *Reflexive language: reported speech and metapragmatics*. (1993). Cambridge University Press.
- Banfield, Ann. 1982. *Unspeakable sentences*. London: Routledge and Kegan Paul.
- Castañeda, Héctor-Neri. 1966. He: A study in the logic of self-consciousness. *Ratio* 7. 130-57.
- Castañeda, Héctor-Neri. 1967a. Indicators and quasi-indicators. *American Philosophical Quarterly* 4. 85-100.
- Castañeda, Héctor-Neri. 1967b. On the logic of self-attribution. *Noûs* 1. 9-21.
- Castañeda, Héctor-Neri. 1968. On the logic of attributions of self-knowledge to others. *Journal of Philosophy* 65.15. 439-456.
- Chomsky, Noam. 1981. *Lectures on government and binding*. Dordrecht: Foris Publications.
- Chomsky, Noam. 1995. *The minimalist program*. Cambridge: The MIT Press.
- Evans, Gareth. 1982. *The varieties of reference*. Oxford: Clarendon Press.
- Fiengo, Robert & Robert May. 1994. *Indices and identity*. Cambridge: The MIT Press.
- Fiengo, Robert & Robert May. 1997. Names and expressions. Ms. CUNY & UC Irvine
- Fodor, Jerry. 1983. *Modularity of mind*. Cambridge: The MIT Press.
- Higginbotham, James. 1983. Logical form, Binding, and nominals. *Linguistic Inquiry* 14. 395-420.
- Higginbotham, James. 1985. On semantics. *Linguistic Inquiry* 16. 547-593.
- Higginbotham, James. 1992. Reference and control. In Richard K. Larson, Sabine Iatridou, Utpal Lahiri and James Higginbotham (eds.) *Control and grammar*. Dordrecht: Kluwer. 79-108.
- Horn, Larry R. 1996. Presupposition and implicature. In Shalom Lappin (ed.) *The Handbook of Contemporary Semantic Theory*. Oxford: Blackwell.
- Kaplan, David. 1977. Demonstratives. In Joseph Almog, John Perry, & Howard Wettstein (eds.) *Themes from Kaplan*. Oxford: Oxford University Press.
- Kaplan, David. 1979. The logic of demonstratives. In Peter French, Theodore Uehling, & Howard Wettstein (eds.) *Contemporary Perspectives in the Philosophy of Language*. Minneapolis: University of Minnesota Press.
- Kripke, Saul. 1980. *Naming and Necessity*. Cambridge: Harvard University Press.
- Lakoff, George. 1972. Linguistics and natural logic. In Donald Davidson & Gil Harman (eds.) *Semantics of Natural Language*. Dordrecht: Reidel. 545-665.
- Lasnik, Howard. 1981. On two recent treatments of disjoint reference. *Journal of Linguistic Research*. 1.4. 48-58. reprinted in Lasnik, Howard. 1989. *Essays on anaphora*. Dordrecht: Kluwer.
- Lasnik, Howard. (this volume). Levels of representation and the elements of anaphora.
- Lasnik, Howard & Mamuro Saito. 1991. On the subject of infinitives. *CLS* 27. 324-343.
- Perry, John. 1979. The problem of the essential indexical. *Noûs* 13. 3-21. reprinted in Nathan Salmon & Scott Soames (eds.) *Propositions and attitudes*. Oxford University Press.

- Pica, Pierre. 1987. On the nature of the reflexivization cycle. In Joyce McDonough & Bernadette Plunkett (eds.) *Proceedings of NELS 17*. GLSA, University of Massachusetts, Amherst. 483-499.
- Reinhart, Tanya. 1983. Coreference and bound anaphora: A restatement of the anaphora questions. *Linguistics and Philosophy* 6. 47-88.
- Richard, Mark. 1983. Direct reference and ascriptions of belief. *Journal of Philosophical Logic* 12. 425-52. reprinted in Nathan Salmon & Scott Soames (eds.) *Propositions and attitudes*. Oxford University Press.
- Sag, Ivan. 1976a. *Deletion and Logical Form*. Ph.D. dissertation, MIT.
- Sag, Ivan. 1976b. A logical theory of verb phrase deletion. *CLS* 12.
- Williams, Edwin. 1977. Discourse and Logical Form. *Linguistic Inquiry* 8. 101-39.

Index of Languages

Amele	40,45f,48	French	136,175,177ff,265,312
Arabic, Classical	295	Frisian	241,245,248,348
Arabic, Moroccan	295	German	136,240,243,245,296,300
Chickasaw	34ff	Hebrew, Biblical	296
Choctaw	32f,38ff	≠ Hòà	174
Creole, Guinea-Bissau	295	Hua	118
Creole, Haitian	296	Hungarian	295
Danish	351ff, 359ff, 372	Icelandic	323-338
Dogrib	44	Italian	265
Dutch	160,240ff,247ff,295,299ff,315,320,345,351,361,373	Japanese	207-232
English	51,58f,63,67f,73f,77ff,115,118ff,130,138,169,175,177,183,188,193,198,228ff,240f,244ff,262ff,269-292,295,299,301f,320,351,355ff,368,372	Lele	118f,130ff
Middle English	241	Mupun	116ff,124f,135
		Norwegian	351ff,359ff,368,372
		Polish	116,118,126ff,137,264
		Salish	52f,69
		Salish Halkomelen	53,61
		Sanskrit	295
		Spanish	136
		St'át'imcets	51-84
		Swedish	248,351ff,359ff
		Yoruba	162f

Index of Names

Abe	76,270,384	Borer	376
Anderson	323f,331	Bouchard	179,333
Andrews	326	Bresnan	221
Ariel	334,338	Broadwell	34,38,42,118
Asher	18	Brody	190
Bach	221	Burzio	27,59,287,312,320
Baker, Carl L.	354	Cantrall	120
Baker, Mark	53,55ff,79,155	Carden	34f
Banfield	382,398	Carlson	73
Barss	252,254	Carter	155
Battistella	371	Castañeda	384
Beghelli	76	Chomsky	1ff,17,27,33,56,65,141ff,147f,183,191,195,197,156,160ff,165,171,174,206,235ff,248,251ff,270,324,335ff,342,344,364,371ff,376,381,383
Belletti	257,291,363		
Berman	22f,27		
Bernódussen	326		
Bilgrami	112		
Bittner	156		

- Cinque 247
 Clahsen 348
 Clements 120,124,270,325,338
 Cloarec-Heiss 124
 Cole 371
 Collins 157
 Comrie 124
 Cooper 120
 Cornelis 334
 Crimmins 90
 Culicover 199f,373
 Dahl 212
 Dalrymple 212
 Davies 47
 Davis 51,53,57ff,60ff,78f
 Demirdache 68ff,78
 Demuth 159
 Diesing 68,78,307,319
 Dik 119
 den Dikken 255,312
 Eissenbeiss 348
 Emonds 229,235
 Enç 70
 Engdahl 247
 Epstein 187
 Erteschik-Shir 83
 Evans 17,58,74,77,80,96,206
 382,384,389
 Everaert 59,242,312,315,323,
 326,349,362
 Faltz 241
 Faraci 191
 Fiengo 1f,5,24,26f,65,97f,102,
 118,189,193,206,212,
 217,221,225,227f,232
 264,381,390,392,394
 Finer 32f
 von Fintel 358
 Fodor 390
 Fox 212
 Frajzyngier 116f,123,125f,134ff,174
 Frege 101,389
 Freidin 141f,145,151
 Fukui 232
 Gerdts 53
 Green 296
 Grice 401
 Grimshaw 159,357
 Groat 258f
 Gordon 34f
 Grodzinsky 58,64ff,75
 Gruber 155,157,159,161,165,174
 177
 Guéron 297,315,320
 Hagège 123,325
 Haiman 118
 Hale 156,276,278,287
 Hayashishita 221
 Heim 17,65f,69,76,83,172,210
 Hellan 323,336,351f,363,375
 Helke 296
 Herburger 83
 Hermon 371
 Hess 78
 Hestvik 4,22f,27,364,368,371f,
 375
 Higginbotham 76,80,96,149,184,190,
 193,200,201,206,210,
 232,381f,394
 Hoekstra, J. 248
 Hoji 208f,210,213ff,220ff
 Holmberg 373
 Horn 401
 Hornstein 254,260
 Horvath 77,81
 Huang 342,347
 Hukari 53,61
 Hyams 323
 Hyman 124
 Jackendoff 155,163,186,199f,276
 373
 Jaspers 160
 Jelinek 55,68
 de Jong 242
 Johnson 262,324
 Kamp 2,9,11f,17ff,22f,27
 Kaplan 105,384ff,398
 Kayne 178f,257,277,302,312
 320
 Keenan 37
 Keyser 276,278,287
 Kinkade 60,78
 Koizumi 262f
 Koopman 172
 Koster 160,235f,238ff,249
 324,361
 Kripke 90,102,390
 Kuroda 232
 Kurcz 129
 Ladusaw 310
 Lakoff 392
 Larson 98,257,277
 Lasnik 1ff,8f,16,18,27,96,141f,
 144,146ff,152,172,228
 253ff,260ff,276,381,399ff
 Lebeaux 145
 Lettinga 296
 Linker 38
 Ludlow 98
 Maling 323,325ff
 Manzini 187,190,324,331,337
 Marác 295

- Martin 258f
 Matthewson 51,53f,58,60ff,67ff,73,78,80
 May 1f,5,24,26f,65,97f,102,118,172,206,212,217,221,225,227f,232,254,259,381,390,392,394
 Meillet 119
 Milsark 51,59,68f,78
 Minkoff 271ff,275ff,282,290
 Mitchell 185
 Mulder 312,317
 Munro 34f
 Musan 68,71
 Napoli 338
 Neidle 272
 Nitch 115,126,128f
 Palayer 130
 Partec 83,185f
 Pereira 212
 Perry 101,384f
 Pesetsky 156,291
 Pica 42,59,161,177f,180,296f,324f,331,349,365,371,404
 Platzack 373
 Pollard 25,362,369
 Pollock 156
 Postma 300,307f,310
 Prince 79
 Postal 1,230,257
 Recanati 90
 Reinhart 4,17,25,27f,37,51,58f,63ff,75f,78,84,149,206,210,228,232,242,246f,270,295,323,332ff,341ff,353f,356ff,361f,369ff,376,381
 Renan 296
 Reuland 4,25,27,37,59,63,242,246,270,295,323,332ff,341ff,353f,356ff,361f,369ff,376
 Reyle 2,9,11ff,17ff,22f,27
 Riad 351
 Richard 384
 Richards 264
 Rizzi 291,363
 Roberts, Craig 27
 Roberts, Ian 190f
 Roberts, John 32,37,39f,47f
 Roberts, Taylor 60,78
 Rochemont 77,81
 Roeper 187,189
 Røgnvaldssen 323
 Rosen 298
 Russell 389
 Safir 51,59,349,351,355,357f,361,364f,368,370f,376
 Sag 25,225,362,369,384
 Saito 254ff,260ff,399
 Salmon 90
 Saxon 44
 Schiffer 90,111
 Schütze 35
 Seely 1,5f,8f,24,26f
 Sells 271,323,325,329,354
 Seuren 161,177
 Shieber 212
 Sigurðsson 323,325ff,333
 Sigurjónsdóttir 323ff,333
 Snyder 161,180
 Sportiche 172
 Stirling 36f
 Stowell 76,83
 Strawson 89ff,110
 Sung 371
 Szabolcsi 315
 Takubo 215
 Tancredi 76f,81
 Tenny 163
 Thráinsson 323,325f,329,332
 Tomioka 225
 Ueyama 207,213
 Uriagereka 1,149,253,256f
 Vainikka 348
 van Deemter 4,17
 van Eijk 69,72,73
 van den Wyngaerd 262
 van der Post 123
 Vikner 351
 Wada 18
 Wasow 221
 Weerman 348
 Weibegué 130
 Weinberg 254,260
 Wescoat 225
 Wexler 324,331
 Whelpton 191
 Wiegel 242f
 Williams, Edwin 155,168,183,194,270,341,362,381
 Williams, Lorna 69
 Yang 142,151,324
 Zaenen 326
 Zribi-Hertz 270,354
 Zwart 262
 Zwarts 310

Authors' addresses and affiliations

Stephen Berman
Seminar für Sprachwissenschaft
University of Tübingen
Wilhelmstr. 113
D-72074 Tübingen
Germany
steve@ims.uni-stuttgart.de

George Aaron Broadwell
Department of Anthropology,
Program in Linguistics and
Cognitive Science
University at Albany,
State University of New York
Albany, NY 12222
U.S.A.
g.broadwell@albany.edu

Hamida Demirdache
Department of Linguistics
University of British Columbia
#E 270, 1866 Main Mall,
Vancouver, BC, V6T-1Z1
Canada
hamida@unixg.ubc.ca

Robert Fiengo
Department of Linguistics
The Graduate Center
City University of New York
33 West 42nd Street
New York, NY 10036
U.S.A.
rfiengo@email.gc.cuny.edu

Zygmunt Frajzyngier
Department of Linguistics, Box 295
University of Colorado,
Boulder, CO 80309
U.S.A.
Zygmunt.Frajzyngier@colorado.edu

Robert Freidin
Department of Philosophy
1879 Hall
Princeton University
Princeton NJ 08544-1006
U.S.A.
bob@clarity.princeton.edu

Jeff Gruber
Department of Linguistics
Université du Québec à Montréal
P.O. Box 8888, Station A
Montréal, Québec H3C 3P8
Canada
gruber.jeffrey@uqam.ca

Arild Hestvik
Department of Linguistics and
Comparative Literature
University of Bergen
Sydnesplassen 7, N-5007 Bergen
Norway
hestvik@uib.no

James Higginbotham
Centre for Linguistics and Philology
University of Oxford
Walton Street, Oxford OX1 2HG
United Kingdom
higgy@ermine.ox.ac.uk

Hajime Hoji
Department of Linguistics
University of Southern California
Los Angeles, CA 90089-1693
U.S.A.
hoji@usc.edu

Jan Koster
Department of General Linguistics
University of Groningen
Oude Kijk in 't Jatstraat 26
9712 EK Groningen
The Netherlands
koster@let.rug.nl

Howard Lasnik
Department of Linguistics
University of Connecticut
Storrs CT 06269-1145
U.S.A.
lasnik@uconnvm.uconn.edu

Robert May
Department of Linguistics
School of Social Sciences
University of California
Irvine, CA 92697
U.S.A.
rmay@uci.edu

Christopher Tancredi
Yokohama National University
79-2 Tokiwadai, Hodogaya-ku
Yokohama, Kanagawa 240
Japan
tancredi@ed.ynu.ac.jp

Seth Minkoff
College of Arts and Sciences
Department of Languages and
Linguistics, MSC 3L
New Mexico State University
PO Box 30001
Las Cruces, NM88003-8001
U.S.A.
minkoff@nmsu.edu

Gertjan Postma
Holland Institute of Generative
Linguistics
Leiden University
P.O. Box 9515
NL-2300 RA Leiden
The Netherlands
postma@rullet.leidenuniv.nl

Eric Reuland
Utrecht institute of Linguistics OTS
Trans 10
3512 JK Utrecht
The Netherlands
eric.reuland@let.ruu.nl

Ken Safir
Department of Linguistics
18 Seminary Place
Rutgers State University
New Brunswick NJ 08903
U.S.A.
safir@ruccs.rutgers.edu

Sigrídur Sigurjónsdóttir
Department of Icelandic Linguistics
University of Iceland
101 Reykjavík
Iceland
siggasig@rhi.hi.nl

