



HAL
open science

A combinatorial approach to jumping particles I: maximal flow regime

Enrica Duchi, Gilles Schaeffer

► **To cite this version:**

Enrica Duchi, Gilles Schaeffer. A combinatorial approach to jumping particles I: maximal flow regime. 2004, pp.12. hal-00159614

HAL Id: hal-00159614

<https://hal.science/hal-00159614>

Submitted on 5 Jul 2007

HAL is a multi-disciplinary open access archive for the deposit and dissemination of scientific research documents, whether they are published or not. The documents may come from teaching and research institutions in France or abroad, or from public or private research centers.

L'archive ouverte pluridisciplinaire **HAL**, est destinée au dépôt et à la diffusion de documents scientifiques de niveau recherche, publiés ou non, émanant des établissements d'enseignement et de recherche français ou étrangers, des laboratoires publics ou privés.

A combinatorial approach to jumping particles I: maximal flow regime

Enrica Duchi and Gilles Schaeffer

ABSTRACT. In this paper we consider a model of particles jumping on a row of cells, called in physics the one dimensional totally asymmetric exclusion process (TASEP). More precisely we deal with the TASEP with two or three types of particles, with or without boundaries, in the maximal flow regime. From the point of view of combinatorics a remarkable feature of these Markov chains is that they involve Catalan numbers in several entries of their stationary distribution.

We give a combinatorial interpretation and a simple proof of these observations. In doing this we reveal a second row of cells, which is used by particles to travel backward. As a byproduct we also obtain an interpretation of the occurrence of the Brownian excursion in the description of the density of particles on a long row of cells.

RÉSUMÉ. Dans cet article nous étudions un modèle de particules qui sautent le long d'une ligne, appelé en physique le processus d'exclusion totalement asymétrique unidimensionnel (TASEP). Plus précisément nous traitons le TASEP avec deux ou trois types de particules, avec ou sans bords, dans le regime de flux maximal. D'un point de vue combinatoire une propriété remarquable de ces chaînes de Markov est qu'elles font intervenir des nombres de Catalan dans plusieurs entrées de leur distribution stationnaire.

Nous donnons une interprétation combinatoire et une preuve simple de ces observations. Ce faisant, nous révélons une deuxième rangée de cases, utilisées par les particules pour retourner en arrière. Nous en déduisons enfin une interprétation de l'apparition d'excursion Brownienne dans la description de la densité des particules le long d'une longue rangée de cases

1. Jumping particles

1.1. The basic model. We shall consider a model of jumping particles on a row of n cells that was studied since the early 90's in physics under the name *one dimensional totally asymmetric exclusion process with boundaries*, or TASEP for short. Although the model is usually presented as a continuous time evolution, it is equivalent, and it is more convenient for us, to define it in discrete time as a Markov chain S^0 on a set of basic configurations:

- A *basic configuration* is a row of n cells, separated by $n+1$ walls (the leftmost and rightmost ones are borders). Each cell is occupied by one particle, and each particle has a type, black or white (see Figure 1).



FIGURE 1. A basic configuration with $n = 10$ cells.

- At time $t = 0$, the system is in a basic configuration $S^0(0)$ (possibly chosen at random).

1991 *Mathematics Subject Classification.* Primary 05A15 ; Secondary 60J05 .

Key words and phrases. bijections, markov chains, Catalan numbers, non equilibrium statistical physics.

The first author was supported by a grant of the city council of Paris, and the second by EC's IHRP Program, within the Research Training Network *Algebraic Combinatorics in Europe*, grant HPRN-CT-2001-00272.

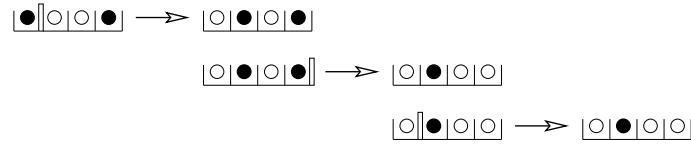

FIGURE 2. An example of evolution, with $n = 4$. The active wall triggering each transition is indicated.

- From time t to $t + 1$, the system evolves from the basic configuration $S^0(t)$ to the basic configuration $S^0(t + 1)$ as follows: an active wall is chosen uniformly at random among the $n + 1$ walls and four cases arise. The complete model for $n = 3$ is presented in Appendix B (see Figure 19).
 - a. If the active wall separates a black particle (on its left) and a white particle (on its right), then the two particles swap.
 - b. If the active wall is the left border and the leftmost cell contains a white particle, then the white particle leaves the system and it is replaced by a black particle.
 - c. If the active wall is the right border and the rightmost cell contains a black particle, then the black particle leaves the system and it is replaced by a white particle.
 - d. Otherwise nothing happens: $S^0(t + 1) = S^0(t)$.

As illustrated by Fig. 2, black particles travel from left to right, while white particles do the opposite. Equivalently one can view white particles as empty cells. Derrida *et al.* [DDM92, DEHP93] proved the following nice results about the evolution of the system S^0 after a long time. First,

$$(1.1) \quad \text{Prob}(S^0(t) \text{ contains } 0 \text{ black particles}) \xrightarrow{t \rightarrow \infty} \frac{1}{C_{n+1}},$$

where $C_{n+1} = \frac{1}{n+2} \binom{2n+2}{n+1}$ is the $(n + 1)$ th Catalan number. More generally, for all $0 \leq k \leq n$,

$$(1.2) \quad \text{Prob}(S^0(t) \text{ contains } k \text{ black particles}) \xrightarrow{t \rightarrow \infty} \frac{\frac{1}{n+1} \binom{n+1}{k} \binom{n+1}{n-k}}{C_{n+1}},$$

where the numerators are called Narayana numbers.

The model is a finite state Markov chain which is clearly ergodic so that the previous limits are in fact the probabilities of the same events in the unique stationary distribution of the chain [HÖ2]. More generally, Derrida *et al.* provided expressions for the stationary probabilities. Since their original work a number of papers have appeared providing alternative proofs and further results on correlations, time evolutions, etc. It should be moreover stressed that the model we presented is a special case among the many existing variants of asymmetric exclusion processes. In particular we have restricted our attention here to the maximal flow regime, where particles enter, travel and exit at the same rate (see however [DS04] for an extension of the present work to general rates). Recent advances and a bibliography can be found for instance in the article [DLS03]. Books about particle processes are [Spo91, Lig85]. However, the remarkable apparition of Catalan numbers is not easily understood from the proofs in the physics literature. As far as we know, these proofs rely either on a *matrix ansatz*, or on a *Bethe ansatz*, both being then proved by a recursion on n .

We propose here a combinatorial derivation of these stationary probabilities. In fact we deal with with a slightly more general model, the three particle TASEP [And88, DEHP93]. This model is a Markov chain S that extends S^0 to three kinds of particles:

- A basic configuration is a row of n cells, separated by $n + 1$ walls (the leftmost and rightmost ones are borders). Each cell is occupied by one particle. Each particle has a type, \bullet (black), \times , or \circ (white), and these three types are ordered: $\bullet > \times > \circ$.



FIGURE 3. A basic configuration with $n = 14$ cells.

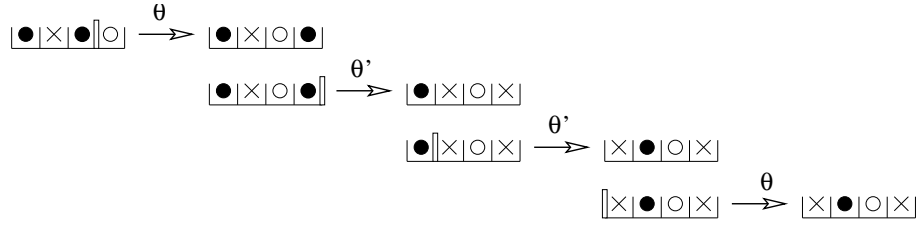

FIGURE 4. An example of evolution with $n = 4$ for the three particle model.

- At each step, together with the selection of the active wall, a choice is made between two transition rules θ and θ' , with equal probability. Then four cases arise:
 - a. The active wall separates two particles such that the type of the left one is larger than the type of the right one. Then the two particles swap. In other terms, the possible local transitions around the active wall are $(\bullet|\circ \rightarrow \circ|\bullet)$, $(\bullet|\times \rightarrow \times|\bullet)$, and $(\times|\circ \rightarrow \circ|\times)$.
 - b. The active wall is the left border. If the leftmost particle is white then it exits, and it is replaced by a black or an \times particle when the rule is respectively θ or θ' . If instead it is an \times particle and the rule is θ' , then it exits and is replaced by a black particle.
 - c. The active wall is the right border. If the rightmost particle is black then it exits, and gets replaced by a white or an \times particle when the rule is respectively θ or θ' . If instead it is an \times particle and the rule is θ' , then it exits and is replaced by a white particle.
 - d. Otherwise nothing happens.

An example of evolution is given in Figure 4. One possible interpretation of this model is that black and white particles still travel respectively to the right and to the left, while \times particles act as empty cells. Another interpretation is with white particles standing for vacancies and black particles overtaking slower \times particles.

1.2. The complete model. Our main ingredient to study the three particle TASEP consists in the construction of a new Markov chain X on a set Ω_n of *complete configurations* that satisfies two main requirements: on the one hand the stationary distribution of the basic chain S can be simply expressed in terms of that of the chain X ; on the other hand the stationary behavior of the chain X is easy to understand. The complete configurations that we introduce for this purpose are made of two rows of n cells containing black, \times , and white particles. The first requirement is met by imposing that disregarding what happens in the second row, the chain X simulates the chain S in the first row. The second requirement is met by adequately choosing the complete configurations and the transition rules so that X clearly has a uniform stationary distribution.

More precisely a pair of rows of particles belongs to Ω_n if: (i) the \times particles appear in pairs to form $|\times|$ -columns, thus delimiting *blocks* of contiguous black and white particles; (ii) each of these blocks contains an equal number of black and white particles; (iii) inside each block, to the left of any vertical wall there are no more white particles than black ones (the *positivity condition*).

An example of a complete configuration is given in Figure 5: from left to right the blocks have successively length 3, 0, 1, and 7. In Section 2 we prove that the cardinality of Ω_n is $\frac{1}{2} \binom{2n+2}{n+1}$, and that, for any $k + \ell + m = n$, the cardinality of the set $\Omega_{k,m}^\ell$ of complete configurations with ℓ $|\times|$ -columns, and k black and m white particles on the top row is $\frac{\ell+1}{n+1} \binom{n+1}{k} \binom{n+1}{m}$.



FIGURE 5. A complete configuration with $n = 14$.

The Markov chain X on Ω_n is defined in terms of two transition rules, T and T' , from the set $\Omega_n \times \{0, \dots, n\}$ to the set Ω_n , that respectively extend the transition rules θ and θ' . These transition

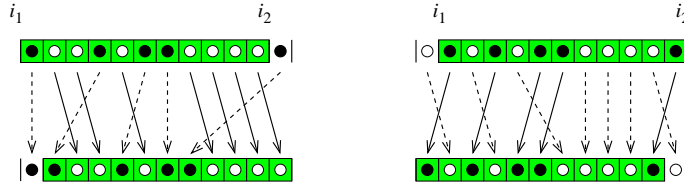

FIGURE 6. A white sweep and a black sweep.

rules are derived in Section 3 from two fundamental bijections \bar{T} and \bar{T}' but can be conveniently described as follows. Given a complete configuration ω and an active wall i , the actions of T and T' on the top row of ω do not depend on the second row, and mimic the actions of θ and θ' as defined by cases a , b , c and d of the description of the three particle TASEP. In particular in the top row, black particles travel from left to right and white particles from right to left. As opposed to that, in the bottom row, T and T' move black and white particles backward. In order to describe this, we first introduce the concept of sweep (see Figure 6):

- A *white sweep* between walls i_1 and i_2 consists in all white particles of the bottom row and between walls i_1 and i_2 simultaneously hopping to the right (some black particles thus being displaced to the left in order to fill the gaps). For well definiteness a white sweep between i_1 and i_2 can occur only if the particle on the right hand side of i_2 is black.
- A *black sweep* between walls i_1 and i_2 consists in all black particles of the bottom row and between walls i_1 and i_2 simultaneously hopping to the left (some white particles thus being displaced to the right in order to fill the gaps). For well definiteness a white sweep between i_1 and i_2 can occur only if the particle on the left hand side of i_1 is white.

Next, around the active wall i , we distinguish the following walls: if $i \neq 0$, let $j_1 < i$ be the leftmost wall such that there are only white particles in the top row between walls j_1 and $i - 1$; if $i \neq n$, let $j_2 > i$ be the rightmost wall such that there are only black particles in the top row between walls $i + 1$ and j_2 . With these definitions, we are in the position to describe the actions of T and T' on the bottom row of a configuration. First whenever an \times particle jumps in the top row, the \times particle below must follow it (so that they remain in the same column). Then the cases a , b and c of the transition rules θ and θ' are complemented in the bottom row as follows:

- a. The moves in the bottom row depend on the transition at the active wall i in the top row (these moves are illustrated by Figures 7–8, and more precisely described in Figures 11–16):
 - $(\times|\circ \rightarrow \circ|\times)$: the $|\times|$ - and $|\circ|$ -columns get exchanged and then a white sweep occurs between walls j_1 and $i - 1$.
 - $(\bullet|\times \rightarrow \times|\bullet)$: the $|\bullet|$ - and $|\times|$ -columns get exchanged and then a black sweep occurs between walls $i + 1$ and $j_2 + 1$ (or between $i + 1$ and j_2 if $j_2 = n$ or the particle on the right hand side of j_2 is a \times).
 - $(\bullet|\circ \rightarrow \circ|\bullet)$: depending whether the particle on the bottom right of the i th wall in ω is white or black, a white sweep occurs between j_1 and $i - 1$, or a black one between $i + 1$ and $j_2 + 1$ (or between $i + 1$ and j_2 if $j_2 = n$ or the particle on the right hand side of j_2 is a \times).
- b. If the entering particle is black, a black sweep occurs between the left border and wall $j_2 + 1$.
- c. If the entering particle is white, a white sweep occurs between wall j_1 and the right border.

Otherwise nothing else happens in the bottom row. Based on T and T' , the Markov chain X is defined in a similar way as the three particle TASEP:

- The set of configurations is the set Ω_n of complete configurations of length n .
- From time t to $t + 1$, the system evolves from the complete configuration $X(t)$ to the next one $X(t + 1)$ as follows: an active wall i is chosen uniformly at random among the $n + 1$

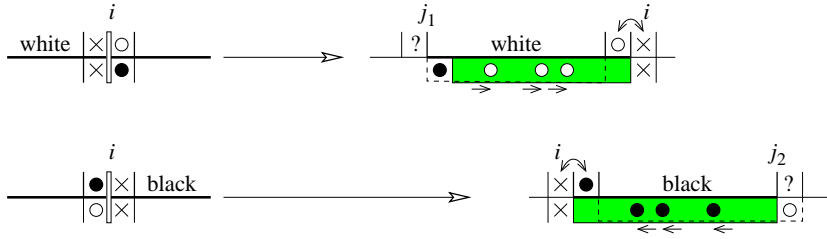

FIGURE 7. Sweeps occurring below transitions $(\times|o \rightarrow o|\times)$ and $(o|\times \rightarrow \times|o)$.

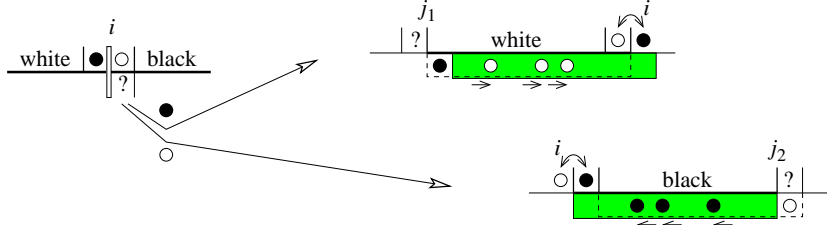

FIGURE 8. Sweeps occurring below the transition $(o|\times \rightarrow \times|o)$.

walls, and one of the two rules T and T' is selected at random with probability $1/2$. The configuration $X(t+1)$ is obtained by applying the selected rule to $X(t)$ at the active wall.

In Section 4, we shall prove that there exists an evolution between any two configurations, i.e., that the Markov chain X is irreducible. There is also a positive probability to stay in any configuration, so that it is aperiodic. Our main result is then the following theorem.

THEOREM 1.1. *The Markov chain X has a uniform stationary distribution.*

The uniformity of the stationary distribution is obtained “by construction”: indeed, in Section 3 we show T (and similarly T') can be described more explicitly as the first component $\Omega_n \times \{0, \dots, n\} \rightarrow \Omega_n$ of a bijection $\bar{T}: \Omega_n \times \{0, \dots, n\} \rightarrow \Omega_n \times \{0, \dots, n\}$; then assuming that at some time t the system is in the uniform distribution on Ω_n , i.e.,

$$\text{Prob}(X(t) = \omega) = \frac{1}{|\Omega_n|},$$

it always remains in the uniform distribution:

$$\begin{aligned} \text{Prob}(X(t+1) = \omega) &= \\ &= \frac{1}{2} \sum_{(\omega', i) \in T^{-1}(\omega)} \text{Prob}(X(t) = \omega') \cdot \frac{1}{n+1} + \frac{1}{2} \sum_{(\omega'', i) \in T'^{-1}(\omega)} \text{Prob}(X(t) = \omega'') \cdot \frac{1}{n+1} \\ &= \frac{1}{2} \cdot |T^{-1}(\omega)| \cdot \frac{1}{|\Omega_n|} \cdot \frac{1}{n+1} + \frac{1}{2} \cdot |T'^{-1}(\omega)| \cdot \frac{1}{|\Omega_n|} \cdot \frac{1}{n+1} = \frac{1}{|\Omega_n|}, \end{aligned}$$

where $T^{-1}(\omega)$ and $T'^{-1}(\omega)$ denote the sets of preimages of ω respectively by T and T' ; the last equality follows from the facts that $T^{-1}(\omega) = \{\bar{T}^{-1}(\omega, j) \mid j = 0, \dots, n\}$ and $T'^{-1}(\omega) = \{\bar{T}'^{-1}(\omega, j) \mid j = 0, \dots, n\}$, and that \bar{T} and \bar{T}' are bijections.

1.3. From the complete to the basic model. According to the theory of finite state Markov chains [HÖ2], Theorem 1.1 ensures that for any choice of initial condition $X(0)$,

$$\text{Prob}(X(t) = \omega) \xrightarrow{t \rightarrow \infty} \frac{1}{|\Omega_n|} = \frac{1}{\frac{1}{2} \binom{2n+2}{n+1}}.$$

This result is sufficient to recover the stationary distribution of the basic model. Indeed observe that by construction hiding the bottom row in the complete model exactly yields the basic model.

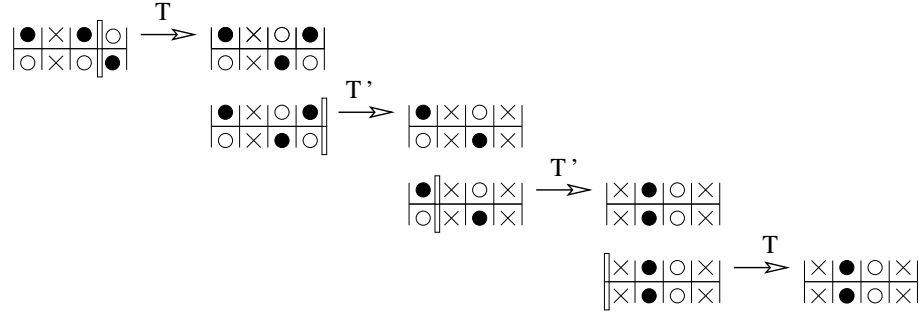

FIGURE 9. An example of evolution with $n = 4$ for the complete three particle model.

Hence we obtain the following combinatorial interpretation for the stationary distribution of the three particle TASEP:

THEOREM 1.2. *Let $\text{top}(\omega)$ denote the top row of a complete configuration ω . Then for any initial configurations $S(0)$ and $X(0)$ with $\text{top}(X(0)) = S(0)$, and any basic configuration r ,*

$$\text{Prob}(S(t) = r) = \text{Prob}(\text{top}(X(t)) = r) \xrightarrow{t \rightarrow \infty} \frac{|\{\omega \in \Omega_n \mid \text{top}(\omega) = r\}|}{|\Omega_n|}.$$

In particular, for any $k + \ell + m = n$, we obtain combinatorially the formula:

$$\text{Prob}(S(t) \text{ contains } k \text{ black and } m \text{ white particles}) \xrightarrow{t \rightarrow \infty} \frac{|\Omega_{k,m}^\ell|}{|\Omega_n|} = \frac{\frac{\ell+1}{n+1} \binom{n+1}{k} \binom{n+1}{m}}{\frac{1}{2} \binom{2n+2}{n+1}}.$$

As discussed in Section 5 this interpretation sheds a new light on some recent results of Derrida *et al.* connecting the TASEP to Brownian excursions [DEL].

1.4. Two variations. Let us denote by Ω_n^0 the subset of configurations of Ω_n without \times particles, and recall that $\Omega_{k,m}^0$ is the subset of configurations of Ω_n^0 with k black and m white particles in the first row. In Section 2 we show that $|\Omega_n^0| = \frac{1}{n+1} \binom{2n+2}{n}$ and that $|\Omega_{k,m}^0| = \frac{1}{n+1} \binom{n+1}{k} \binom{n+1}{m}$. As we did for Ω_n , we define a Markov chain on the set Ω_n^0 whose evolution is determined just by the application of T^0 , which is the restriction of T to the subset Ω_n^0 . The behavior of the first row in this Markov chain then exactly mimics the basic TASEP with two particles. Moreover, the associated application \hat{T}^0 is a bijection from $\Omega_n^0 \times \{0, \dots, n\}$ into itself, so that the uniform distribution is again stationary for this Markov chain. Finally it is also an ergodic Markov chain. Therefore

$$\text{Prob}(X^0(t) = \omega) \xrightarrow{t \rightarrow \infty} \frac{1}{|\Omega_n^0|},$$

and the stationary distribution of the two particles TASEP is combinatorially expressed as

$$\text{Prob}(S^0(t) = r) \xrightarrow{t \rightarrow \infty} \frac{|\{\omega \in \Omega_n^0 \mid \text{top}(\omega) = r\}|}{|\Omega_n^0|}.$$

The results (1.1)-(1.2) are then immediate consequences. The basic and complete system with two particles for $n = 3$ are represented in Figures 19–20 in Appendix B.

Another variant of TASEP found in the literature is the TASEP with periodic boundary conditions, in which the particles travel around a circle (see Figure 10, the circle is rigid, not subject to rotation). Since there are no border walls in these configurations, the Markov chain \hat{S} is defined using only Case *a* of the transition rule θ of the TASEP with boundaries. In the periodic TASEP the numbers of black, \times and white particles do not change, and the case without \times particle immediately leads to a uniform stationary distribution. Our approach is easily adapted to deal with the more interesting case where there are \times particles. Indeed one can associate to this model a new set $\hat{\Omega}_n$ of complete configurations, made of two rows of cells arranged on a circle. As for Ω_n , configurations

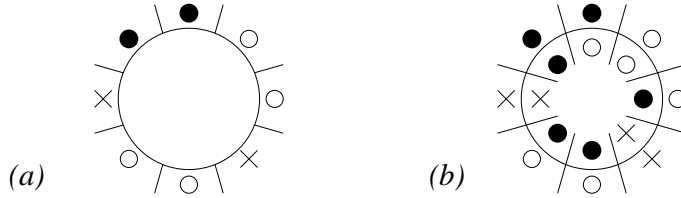

FIGURE 10. A basic (a) and a complete (b) configuration for the three particle TASEP on a circle

of $\widehat{\Omega}_n$ are subject to the condition that the blocks between two $|\times|$ -columns, when read in clockwise direction, satisfy the positivity constraints. Since the number of black, white and \times particles never change in this system, we concentrate on the set $\widehat{\Omega}_{k,m}^\ell$ of configurations of $\widehat{\Omega}_n$ with ℓ $|\times|$ -columns, k black and m white particles in the top row. In Section 2 we prove that cardinality of $\widehat{\Omega}_{k,m}^\ell$ is $\binom{n}{k} \binom{n}{m}$. Again Case *a* of the evolution rule T is sufficient to define an evolution rule \widehat{T} on $\widehat{\Omega}_{k,m}^\ell$ and an associated bijection from $\widehat{\Omega}_{k,m}^\ell \times \{0, \dots, n-1\}$ to itself. The same arguments as for the chain X show that the resulting Markov chain \widehat{X} has uniform stationary distribution, and this yields:

$$\text{Prob}(\widehat{X}(t) = \omega) \xrightarrow{t \rightarrow \infty} \frac{1}{|\widehat{\Omega}_{k,m}^\ell|} = \frac{1}{\binom{n}{k} \binom{n}{m}}.$$

The stationary distribution of the TASEP \widehat{S} is then combinatorially expressed in terms of complete configurations:

$$\text{Prob}(\widehat{S}(t) = r) \xrightarrow{t \rightarrow \infty} \frac{|\{\omega \in \widehat{\Omega}_{k,m}^\ell \mid \text{top}(\omega) = r\}|}{|\Omega_{k,m}^\ell|}.$$

1.5. Outline of the rest of the paper. In Section 2 the different classes of complete configurations are enumerated. The main bijections are studied in Section 3, and in Section 4 the chains are proven to be irreducible. Finally some concluding remarks are gathered in Section 5.

2. Complete configurations and the cycle lemma

In this section we state the enumerative lemmas (see proofs in Appendix A). Given a complete configuration of length n , and an integer j , $0 \leq j \leq n$, let $B(j)$ and $W(j)$ be respectively the numbers of black and white particles lying in the first j -th columns (from left to right), and set $E(j) = B(j) - W(j)$. In other terms, the quantities $B(j)$, $W(j)$ and $E(j)$ represent the number of black particles, the number of white particles, and their difference on the left-hand side of the j th wall. In particular, $E(0) = E(n) = 0$, and Condition (iii) of the definition of complete configurations reads $E(j) \geq 0$ for $j = 0, \dots, n$ (this is why we call it a positivity condition). Readers with a background in enumerative combinatorics may recognize bicolored Motzkin paths in disguise [Sta99, Ch. 6].

LEMMA 2.1. *The number $|\Omega_n|$ of complete configurations of Ω_n is $\frac{1}{2} \binom{2n+2}{n+1}$.*

LEMMA 2.2. *Let k, ℓ, m, n be non negative integers with $k + \ell + m = n$. The number $|\Omega_{k,m}^\ell|$ of complete configurations of Ω_n with ℓ $|\times|$ -columns, k black and m white particles on the top row, and m black and k white particles on the bottom row is $\frac{\ell+1}{n+1} \binom{n+1}{k} \binom{n+1}{m}$.*

LEMMA 2.3. *The number $|\Omega_p^\ell|$ of complete configurations of Ω_n , for $p + \ell = n$, with ℓ $|\times|$ -columns, and p black and p white particles distributed between the two rows is $\frac{\ell+1}{n+1} \binom{2n+2}{p}$.*

Remark. As already said, when $\ell = 0$ we have configurations with just two kinds of particles. In this case, from Lemma 2.2 and Lemma 2.3, we have $|\Omega_{k,m}^0| = \frac{1}{n+1} \binom{n+1}{k} \binom{n+1}{m}$ and $|\Omega_n^0| = \frac{1}{n+1} \binom{2n+2}{n}$.

LEMMA 2.4. *The number $|\widehat{\Omega}_{k,m}|$ of configurations of $|\widehat{\Omega}_n|$ having ℓ $|\times|$ -columns, k black particles at the top, and m at the bottom is $\binom{n}{k} \binom{n}{m}$.*

3. The bijections \bar{T} and \bar{T}'

In this section we describe the mappings \bar{T} and \bar{T}' case by case and check that they are bijections from $\Omega_n \times \{0, \dots, n\}$ to itself.

We shall partition the set $\Omega_n \times \{0, \dots, n\}$ into classes $A_{a'_1}, A_{a''_1}, A_{a_2}, A_{a_3}, A_{b_1}, A_{b_2}, A_{c_1}, A_{c_2}, A_d$, and describe, for each class A_α , its images $B_\alpha = \bar{T}(A_\alpha)$ and $B'_\alpha = \bar{T}'(A_\alpha)$ under the action of \bar{T} and \bar{T}' . From now on, (ω, i) denotes an element of the current class, and (ω', j) its image, either by \bar{T} or by \bar{T}' depending on the context. In the pairs (ω, i) and (ω', j) , i and j refer to walls of the configurations ω and ω' , and i is called the active wall of ω . Following the notations of Section 1, when $i \neq 0$, we also consider $j_1 < i$ the smallest integer such that in the top row of ω all cells between walls j_1 and $i - 1$ contain white particles. Symmetrically, when $i \neq n$, we consider $j_2 > i$ the largest integer such that in the top row of ω all cells between walls $i + 1$ and j_2 contain black particles. In the first few cases the applications \bar{T} and \bar{T}' do not differ, so a common description is given. Later on, they are distinguished.

A_{a_1} The active wall of ω separates in the top row a black particle P and a white particle Q . Then in the top row the particles P and Q swap. In the bottom row, the sweep that occurs depends on the type of the particle R that is below Q in ω (see Figure 11):

$A_{a'_1}$ The particle R is black. Then $j = j_1$ and, in the bottom row, a white sweep occurs between walls j and i . Observe that ω' belongs to Ω_n . Indeed ω' can also be described as obtained from ω by moving a $|\bullet^\circ|$ -column from the right of the i th wall to the right of the j th. But moving a $|\bullet^\circ|$ -column has no effect on the positivity constraints.

The image $B_{a'_1} = B'_{a'_1}$ of the class $A_{a'_1}$ consists of pairs (ω', j) such that: there is not a white particle on the left-hand side of the j th wall in the top row of ω' , there is a $|\bullet^\circ|$ -column on its right-hand side, and the sequence of white particles on the right-hand side of the j th wall in the top row is followed by a black particle.

$A_{a''_1}$ The particle R is white. Then $j = j_2$ and, in the bottom row, a black sweep occurs between walls $i + 1$ and $j + 1$ (resp. $i + 1$ and j) if on the right of j there is a white particle (resp. an $|\times|$ -column or the border). The new configuration ω' satisfies clearly the positivity condition at all walls but i . But there is a $|\bullet^\circ|$ -column on the right of i in ω , so that in this configuration $B(i) - W(i) \geq 2$, and this quantity remains non negative in ω' .

The image $B_{a''_1} = B'_{a''_1}$ of the class $A_{a''_1}$ consists of pairs (ω', j) with a $|\bullet^\circ|$ -column, an $|\times|$ -column, or the border on the right-hand side of the j th wall of ω' and such that there is a non-empty sequence of black particles on the left-hand side of the j th wall in the top row, followed by a white particle.

A_{a_2} The active wall of ω separates in the top row an \times particle P and a white particle Q . We remark that, in order to satisfy the positivity constraint, the cell under Q must contain a black particle R (see Figure 12, left-hand side). Then in the top row the particles P and Q swap. In the bottom row, the \times particle under P and the particle R swap, and then a white sweep occurs between walls $j = j_1$ and $i - 1$. Observe that ω' belongs to Ω_n . Indeed ω' can also be described as obtained from ω by moving a $|\bullet^\circ|$ -column from the right of the i th wall to the right of the j th.

The image $B_{a_2} = B'_{a_2}$ of the class A_{a_2} consists of pairs (ω', j) such that: there is not a white particle on the left-hand side of the j th wall in the top row of ω' , there is a $|\bullet^\circ|$ -column on its right-hand side and the sequence of white particles on the right-hand side of the j th wall in the top row is followed by an \times particle.

A_{a_3} The active wall of ω separates in the top row an black particle P and an \times particle Q . This time the cell under P must contain a white particle R (see Figure 12, right-hand side). Then the particles P and Q swap. In the bottom row, the particle R and the \times particle under Q swap, and then a black sweep occurs between walls $i + 1$ and $j + 1$ with $j = j_2$ (or between walls $i + 1$ and j if an $|\times|$ -column or the border is reached). The configuration

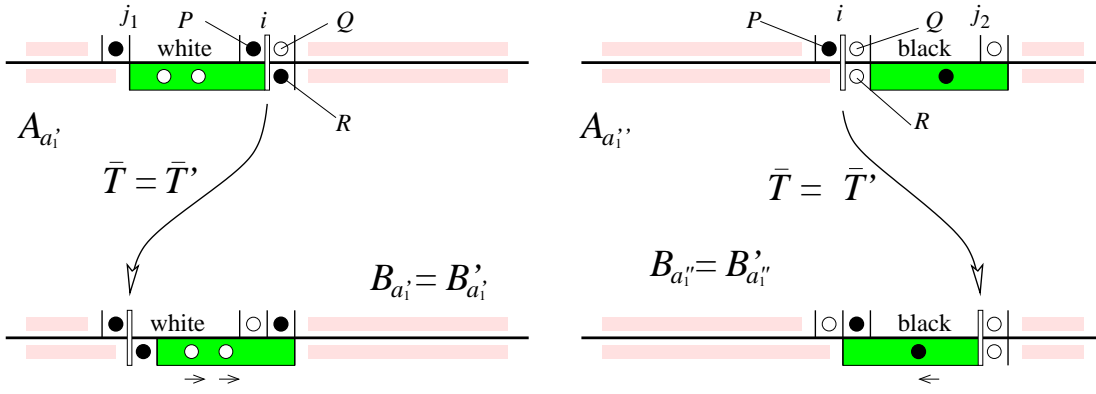

FIGURE 11. Jump moves in the $(\bullet|\circ \rightarrow \circ|\bullet)$ case.

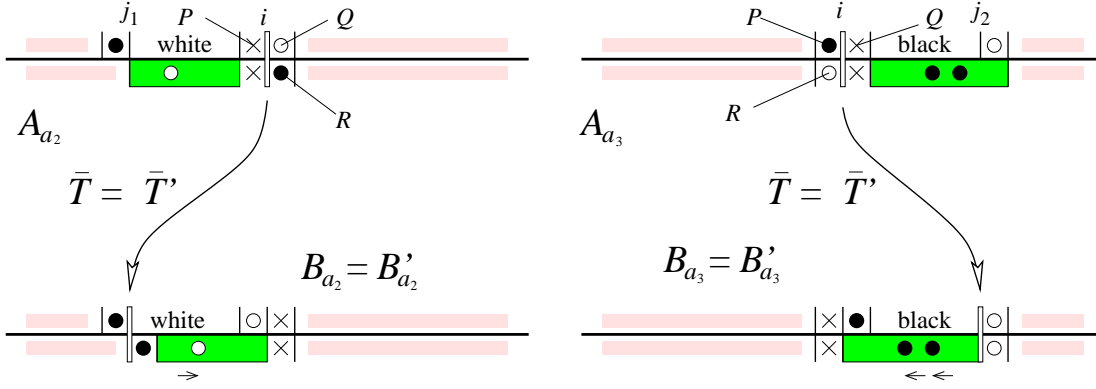

FIGURE 12. Jump moves in the $(\times|\circ \rightarrow \circ|\times)$ and $(\bullet|\times \rightarrow \times|\bullet)$ cases.

ω' belongs to Ω_n since a $|\times|$ and a $|\bullet|$ -column swap and no other black particle moves to the right.

The image $B_{a_3} = B'_{a_3}$ of the class A_{a_3} consists of pairs (ω', j) with a $|\circ|$ -column, an $|\times|$ -column, or the border on the right of the j th wall of ω' and such that there is a non-empty sequence of black particles on the left-hand side of the j th wall in the top row, followed by an \times particle.

A_{b_1} The active wall of ω is the left border with a white particle Q on its right in the top row. Again, the cell under Q must contain a black particle R (see Figure 13). Then the images by \bar{T} and \bar{T}' are different:

- \bar{T} is applied. First the particles Q and R are replaced by $|\bullet|$ -column. Then $j = j_2$ and, in the bottom row, a black sweep occurs between walls 1 and $j + 1$ (or between walls 1 and j if an $|\times|$ -column or the border is reached). The configuration ω' belongs to Ω_n . Indeed no black particle moves to the right.

The image B_{b_1} of the class A_{b_1} consists of pairs (ω', j) with a $|\circ|$ -column, an $|\times|$ -column, or the border on the right of the j th wall of ω' and such that there is a non-empty sequence of black particles on the left of the j th wall in the top row, ending at the left border.

- \bar{T}' is applied. Then both Q and R particles are replaced by \times particles, and $j = 0$. The configuration ω' belongs to Ω_n since a $|\bullet|$ -column was replaced by an $|\times|$ -column.

The image B'_{b_1} of A_{b_1} consists of pairs $(\omega', 0)$ with an $|\times|$ -column on the left border.

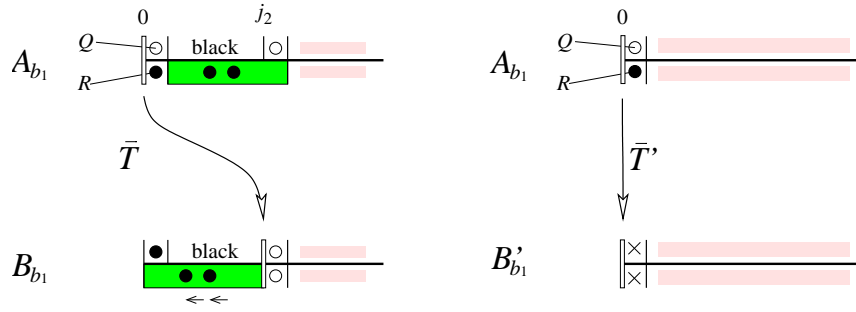

FIGURE 13. Active left border with a white particle in the top row.

FIGURE 14. Active left border with an x particle in the top row.

FIGURE 15. Active right border with a black particle in the top row.

FIGURE 16. Active right border with a x particle in the top row.

- A_{b_2} The active wall of ω is the left border with an \times particle Q on its right in the top row. The particle R under Q must be an \times particle (see Figure 14):
- \bar{T} is applied. Then $\omega' = \omega$ and $j = 0$. The image B_{b_2} of the class A_{b_2} consists of pairs $(\omega', 0)$ with a $|\times|$ -column on the left border.
 - \bar{T}' is applied. First, the particles Q and R are replaced by a $|\bullet^\circ|$ -column. Then a black sweep occurs between walls 1 and $j+1$ with $j = j_2$ (or between 1 and j if a $|\times|$ -column or the border is reached). The configuration ω' belongs to Ω_n since no black particle moves to the right.
The image B'_{b_2} of the class A_{b_2} consists of pairs (ω', j) with a $|\bullet^\circ|$ -column, a $|\times|$ -column, or the border on the right of the j th wall of ω' and such that there is a non-empty sequence of black particles on the left of the j th wall in the top row, ending at the left border.
- A_{c_1} The active wall of ω is the right border with a black particle Q on its left in the top row. The cell under Q must contain a white particle R (see Figure 15):
- \bar{T} is applied. First the particles Q and R are replaced by a $|\bullet^\circ|$ -column. Then $j = j_1$ and, in the bottom row, a white sweep occurs between walls j and $n-1$. The configuration ω' belongs to Ω_n since the transformation amounts to moving and flipping a $|\bullet^\circ|$ -column.
The image B_{c_1} of the class A_{c_1} consists of pairs (ω', j) such that: there is not a white particle on the left-hand side of the j th wall of ω' in the top row, there is a $|\bullet^\circ|$ -column on its right-hand side, and such that the sequence of white particles on the right-hand side of the j th wall in the top row ends at the right border.
 - \bar{T}' is applied. Then both Q and R are replaced by \times particles, and $j = n$. The configuration ω' belongs to Ω_n since a $|\bullet^\circ|$ -column is replaced by a $|\times|$ -column.
The image B'_{c_1} of A_{c_1} consists of pairs (ω', n) with an $|\times|$ -column on the right border.
- A_{c_2} The active wall of ω is the right border with an \times particle Q on its left in the top row. The particle R under Q must be an \times particle (see Figure 16). Then the image by \bar{T} and \bar{T}' are:
- \bar{T} is applied. Then $\omega' = \omega$ and $j = n$. The image B_{c_2} of the class A_{c_2} consists of pairs (ω', n) with a $|\times|$ -column on the right border.
 - \bar{T}' is applied. First, the particles Q and R are replaced by a $|\bullet^\circ|$ -column. Then a white sweep occurs between walls $j = j_1$ and $n-1$. The configuration ω' belongs to Ω_n . Indeed the operation amounts to the introduction of a $|\bullet^\circ|$ -column at the j th wall.
The image B'_{c_2} of the class A_{c_2} consists of pairs (ω', j) such that: there is not a white particle on the left-hand side of the j th wall of ω' in the top row, there is a $|\bullet^\circ|$ -column on its right-hand side, and the sequence of white particles on the right-hand side of the j th wall in the top row ends at the right border.
- A_d This class contains all the remaining cases. For these configurations the mappings \bar{T} and \bar{T}' do not change anything, that is, for $(\omega, i) \in A_d$, $\bar{T}(\omega, i) = \bar{T}'(\omega, i) = (\omega, i)$.

THEOREM 3.1. *The mappings $\bar{T}, \bar{T}' : \Omega_n \times \{0, \dots, n\} \rightarrow \Omega_n \times \{0, \dots, n\}$ are bijections.*

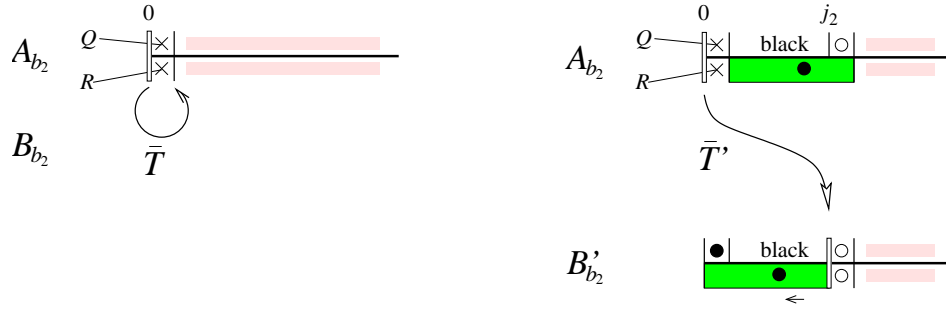
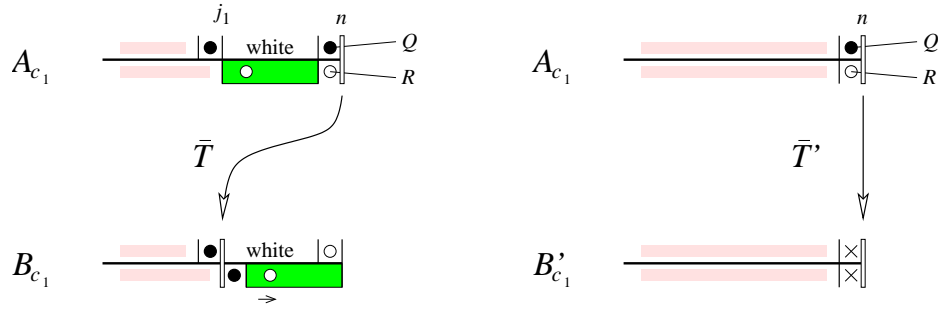
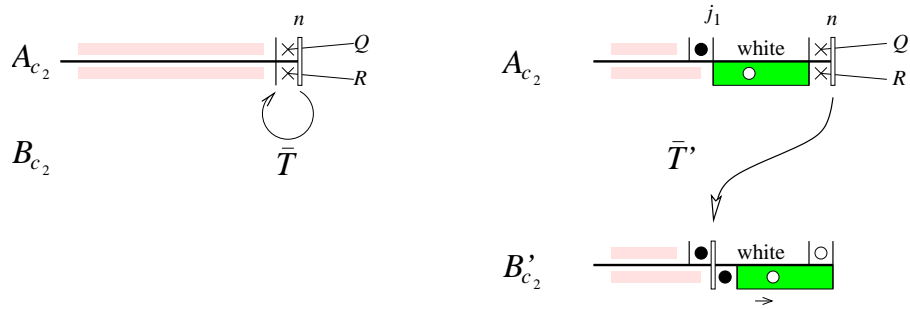
PROOF. In each case the transformations are clearly reversible. We conclude by checking that both $\{B_{a'_1}, B_{a''_1}, B_{a_2}, B_{a_3}, B_{b_1}, B_{b_2}, B_{c_1}, B_{c_2}, B_d\}$ and $\{B_{a'_1}, B_{a''_1}, B_{a_2}, B_{a_3}, B'_{b_1}, B'_{b_2}, B'_{c_1}, B'_{c_2}, B_d\}$ are partitions of $\Omega_n \times \{0, \dots, n\}$. \square

For the two particle model, it suffices to observe that the restriction of \bar{T} to $\Omega_n^0 \times \{0, \dots, n\}$ is a bijection onto $\Omega_n^0 \times \{0, \dots, n\}$. For the three particle model on the circle, a bijection from $\widehat{\Omega}_{k,m}^\ell$ onto itself is readily obtained using the constructions in cases $A_{a'_1}, A_{a''_1}, A_{a_2}$ and A_{a_3} .

4. Paths between two configurations

In this section we verify that the Markov chains X^0, \widehat{X} and X are irreducible, *i.e.* that there is a positive probability to go from any configuration ω to any other one ω' . In other terms we need

to prove that the transition graph defined on Ω_n by T and T' is connected. The proof is based on an observation about iterating the bijections \bar{T} or \bar{T}' , and on induction on n .

To every pair (ω, i) of $\Omega_n \times \{0, \dots, n\}$ we associate a reduced configuration ω^i in Ω_{n-1} , obtained from ω by deleting two particles around the wall i using the following rules:

- if (ω, i) belongs to A_{a_1} , A_{a_2} or A_{b_1} then ω^i is obtained by removing the $|\bullet|$ -column on the right-hand side of the wall i (particles Q and R on the corresponding figure),
- if (ω, i) belongs to $A_{a_1'}$ then ω^i is obtained by removing the two particles forming the configurations $\bullet|_o$ around the wall i (particles P and R on the corresponding figure),
- if (ω, i) belongs to A_{a_3} or A_{c_1} then ω^i is obtained by removing the $|\bullet|$ -column on the left-hand side of the wall i (particles P and R on the corresponding figure),
- if (ω, i) belongs to A_{b_2} , then ω^i is obtained by removing the $|\times|$ -column on the left border,
- if (ω, i) belongs to A_{c_2} , then ω^i is obtained by removing the $|\times|$ -column on the right border.

LEMMA 4.1. *Let ω' be a configuration of Ω_{n-1} . Let $S(\omega')$ be the set of pairs (ω, i) of $\Omega_n \times \{0, \dots, n\}$ having ω' as reduced configuration, i.e. such that $\omega^i = \omega'$. Then:*

- *the set $S(\omega')$ is a cyclic orbit of \bar{T}' : given $(\omega, i) \in S$ all other elements of S can be reached by successive applications of \bar{T}' ,*
- *the set $S(\omega') \setminus \{(\omega'_0, 0), (\omega'_n, n)\}$ is a cyclic orbit of \bar{T} , where ω'_0 is the configuration $|\times| \omega'$ and ω'_n is the configuration $\omega' |\times|$.*

PROOF. As can be checked on the left-hand sides of Figures 11 and 12, iterating \bar{T} , or \bar{T}' from a pair (ω, i) of A_{a_1} or A_{a_2} , the selected wall moves to the left with the pair of particles P and R , and successively stops on the right hand side of every black or \times particle of the top row, until it reaches the left border. Similarly, as can be checked on the right-hand sides of Figures 11 and 12, iterating \bar{T} or \bar{T}' from a pair of $A_{a_1'}$ or A_{a_2} , the selected wall moves to the right with the pair of particles P and R , stopping on the left hand side of every white and \times particles of the top row, until it reaches the right border.

As shown by Figures 13–16, the application \bar{T} and \bar{T}' behave differently when the border is reached: \bar{T}' visits the configurations ω'_0 or ω'_n while \bar{T} skips them and restart moving in the opposite direction.

Starting from an element (ω, i) all other elements of $S(\omega')$ (respectively $S \setminus \{\omega'_0, \omega'_n\}$) are thus visited in a cycle by successive applications of \bar{T}' (respectively \bar{T}). \square

Lemma 4.1 provides us with cycles in the transition graph on Ω_n , and each cycle is associated to a reduced configuration of Ω_{n-1} . The next lemma transports transitions from Ω_{n-1} to Ω_n .

LEMMA 4.2. *Let $(\omega', j) = \bar{T}'(\omega, i)$ be a transition between two configurations of Ω_{n-1} . Then there exists pairs $(\omega_+, i_+) \in S(\omega)$ and $(\omega'_+, j_+) \in S(\omega')$ such that $(\omega'_+, j_+) = \bar{T}'(\omega_+, i_+)$.*

PROOF. In each case of Figures 11–16, an $|\times|$ -column can be inserted, either on the left or on the right border, without interfering with the action of \bar{T}' . \square

Lemma 4.2 gives a transition between an element of the cycle associated to ω and an element of the cycle associated to ω' . Taking the connectivity of the transition graph on Ω_{n-1} as induction hypothesis, we conclude that all cycles of Lemma 4.1 belong to the same connected component of the transition graph on Ω_n . Since every element of Ω_n belong to a cycle, this concludes the proof of the irreducibility of X . The proofs for X^0 and \hat{X} are similar.

5. Conclusions and relations to Brownian excursions

The starting point of this paper was a “combinatorial Ansatz”: the stationary distribution of the two and three particle TASEP with or without boundaries can be expressed in terms of Catalan numbers hence should have a nice combinatorial interpretation. In our interpretation, configurations of the TASEP are completed by a (usually hidden) second row in which particles go back. The

resulting system has a uniform stationary distribution so that the probability of a given TASEP configuration just reflects the diversity of possible rows hidden below it.

We do not claim that our combinatorial interpretation is of any physical relevance. However, apart from explaining the “magical” occurrence of Catalan numbers in the problem, it sheds new light on the recent results of Derrida *et al.* [DEL] connecting the TASEP with Brownian excursion. More precisely, using explicit calculations, Derrida *et al.* show that the density of black particles in configurations of the two particle TASEP can be expressed in terms of a pair (e_t, b_t) of independent processes, a Brownian excursion e_t and a Brownian motion b_t . In our interpretation these two quantities appear at the discrete level, associated to each complete configuration ω of Ω_n^0 :

- The role of the Brownian excursion for ω is played by the halved differences $e(i) = \frac{1}{2}(B(i) - W(i))$ between the number of black and white particles sitting on the left of the i th wall, for $i = 0, \dots, n$. By definition of complete configurations, $(e(i))_{i=0, \dots, n}$ is a discrete excursion, that is, $e(0) = e(n) = 0$, $e(i) \geq 0$ and $|e(i) - e(i-1)| \in \{0, 1\}$, for $i = 0, \dots, n$.
- The role of the Brownian motion is played for ω by the differences $b(i) = B_{top}(i) - B_{bot}(i)$ between the number of black particles sitting in the top and in the bottom row, on the left of the i th wall, for $i = 0, \dots, n$. This quantity $(b(i))_{i=0, \dots, n}$ is a discrete walk, with $|b(i) - b(i-1)| \in \{0, 1\}$ for $i = 0, \dots, n$.

Since $e(i) + b(i) = 2B_{top}(i) - i$, these quantities allow one to describe the cumulated number of black particles in the top row of a complete configuration. Accordingly, the density in a given segment (i, j) is $(B_{top}(j) - B_{top}(i))/(j - i) = \frac{1}{2} + \frac{e(j) - e(i)}{2(j-i)} + \frac{b(j) - b(i)}{2(j-i)}$. This is a discrete version of the quantity considered by Derrida *et al.* in [DEL].

Now the two walks $e(i)$ and $b(i)$ are correlated since one is stationary when the other is not, and vice-versa: $|e(i) - e(i-1)| + |b(i) - b(i-1)| = 1$. Given ω , let $I_e = \{\alpha_1 < \dots < \alpha_p\}$ be the set of indices of $|\bullet|$ - and $|\circ|$ -columns, and $I_b = \{\beta_1 < \dots < \beta_q\}$ the set of indices of $|\circ|$ - and $|\bullet|$ -columns ($p + q = n$). Then the walk $e'(i) = e(\alpha_i) - e(\alpha_{i-1})$ is the excursion obtained from e by ignoring stationary steps, and the walk $b'(i) = b(\beta_i) - b(\beta_{i-1})$ is obtained from b in the same way. Conversely given a simple excursion e' of length p , a simple walk b' of length q and a subset I_e of $\{1, \dots, p + q\}$ of cardinality p , two correlated walks e and b , and thus a complete configuration ω can be uniquely reconstructed. The consequence of this discussion is that the uniform distribution on Ω_n^0 corresponds to the uniform distribution of triples (I_e, e', b') where, given I_e , the processes e' and b' are independent.

A direct computation shows that in the large n limit, with probability exponentially close to 1, a random configuration ω is described by a pair (e', b') of walks of roughly equal lengths $n/2 + O(n^{1/2+\epsilon})$. In particular, up to multiplicative constants, the normalized pairs $(\frac{e'(tn/2)}{n^{1/2}}, \frac{b'(tn/2)}{n^{1/2}})$ and $(\frac{e(tn)}{n^{1/2}}, \frac{b(tn)}{n^{1/2}})$ both converge to the same pair (e_t, b_t) of independent processes, with e_t a standard Brownian excursion and b_t a standard Brownian walk.

We thus obtain a combinatorial interpretation of the appearance of the pair (e_t, b_t) in the two particle TASEP. The result now extends immediately to the three particle TASEP: it follows from the construction of Lemma 2.1 that the uniform distribution on Ω_n leads to a pair (e', b') where the continuum limit of e' is now a reflected Brownian bridge, while b' remains a Brownian bridge. More generally conditioning on the number of x particles amounts to conditioning on the local time at the origin of the process e .

Another possible outcome of our approach could be an explicit construction of a continuum TASEP by taking the limit of the Markov chain X^0 , viewed as a Markov chain on pairs of walks. An appealing way to give a geometric meaning to the transitions in the continuum limit could be to use a representation in terms of parallelogram polyominoes, using the process $e(t)$ (or e_t in the continuum limit) to describe the width of the polyomino and the process $b(t)$ (or b_t in the continuum limit) to describe the vertical displacement of its spine.

Acknowledgments. Referees are warmly thanked for their great help in improving the paper.

References

- [And88] Liggett Andjel, Bramson, *Shocks in the asymmetric exclusion process*, Prob. Th. Related Fields **78** (1988), 231–247.
- [DDM92] B. Derrida, E. Domany, and D. Mukamel, *An exact solution of a one dimensional asymmetric exclusion model with open boundaries*, J. Stat. Phys. **69** (1992), 667–687.
- [DEHP93] B. Derrida, M.R. Evans, V. Hakim, and V. Pasquier, *Exact solution of a one-dimensional asymmetric exclusion model using a matrix formulation*, J. Phys. A: Math. **26** (1993), 1493–.
- [DEL] B. Derrida, C. Enaud, and J. L. Lebowitz, *The asymmetric exclusion process and brownian excursions*, Available electronically as [arXiv:cond-mat/0306078](https://arxiv.org/abs/cond-mat/0306078).
- [DLS03] B. Derrida, J. L. Lebowitz, and E. R. Speer, *Exact large deviation functional of a stationary open driven diffusive system: the asymmetric exclusion process*, J. Stat. Phys. **110** (2003), 775–810.
- [DS04] E. Duchi and G. Schaeffer, *A combinatorial approach to jumping particles II: general boundary conditions*, Submitted, 2004.
- [Hö2] O. Häggström, *Finite markov chains and algorithmic applications*, Cambridge University Press, 2002.
- [Lig85] T. M. Liggett, *Interacting particle systems*, Springer, New York, 1985.
- [Lot99] M. Lothaire, *Combinatorics on words*, 2nd ed., Cambridge University Press, 1999.
- [Spo91] H. Spohn, *Large scale dynamics of interacting particles*, Texts and Monographs in Physics, Springer, 1991.
- [Sta99] R. Stanley, *Enumerative combinatorics, volume ii*, Cambridge University Press, 1999.

Appendix A. Proofs of the enumerative lemmas of Section 2

LEMMA 2.1. *The number $|\Omega_n|$ of complete configurations of Ω_n is $\frac{1}{2} \binom{2n+2}{n+1}$.*

PROOF. Let Γ_{n+1} be the set of (unconstrained) configurations of $n + 1$ black and $n + 1$ white particles distributed between two rows of $n + 1$ cells, so that $|\Gamma_{n+1}| = \binom{2n+2}{n+1}$. Among these configurations, we restrict our attention to those ending with a column with a black particle in the top cell and a white particle in the bottom cell (called a $|\bullet/\circ|$ -column for simplicity), and those ending with a column with two black particles (a $|\bullet/\bullet|$ -column). Let us denote the set of these configurations by $\bar{\Gamma}_{n+1}$. Exchanging black and white colors is obviously a bijection between $\bar{\Gamma}_{n+1}$ and its complement in Γ_{n+1} so that $|\bar{\Gamma}_{n+1}| = \frac{1}{2} \binom{2n+2}{n+1}$.

The proof of the lemma now consists in the following bijection ϕ between Ω_n and $\bar{\Gamma}_{n+1}$ (see Figure 17). Given $\omega \in \Omega_n$, its image $\phi(\omega)$ is obtained as follows: First, if the number of $|\times|$ -columns of ω is even, add a $|\bullet/\circ|$ -column at the end of ω , otherwise add to it an $|\times|$ -column. Then replace the first half of the $|\times|$ -columns by $|\circ/\circ|$ -columns, and the remaining half by $|\bullet/\bullet|$ -columns (from left to right). By construction the resulting $\phi(\omega)$ belongs to $\bar{\Gamma}_{n+1}$. Consider now $\gamma \in \bar{\Gamma}_{n+1}$, and let $d = \min(E(j))$ be the depth of γ . Then set $j_i = \min\{j \mid E(j) = -2i\}$, and $j'_i = \max\{j \mid E(j-1) = -2i\}$, for $i = 1, \dots, |d|$, and define the application ψ that first changes columns j_i and j'_i into $|\times|$ -columns, and then removes the last column. By construction the blocks between two of the modified columns of γ satisfy the positivity condition, so that $\phi(\gamma) \in \Omega_n$, and the applications ϕ and ψ are clearly inverses of each other. \square

LEMMA 2.2. *Let k, ℓ, m, n be non negative integers with $k + \ell + m = n$. The number $|\Omega_{k,m}^\ell|$ of complete configurations of Ω_n with ℓ $|\times|$ -columns, k black and m white particles in the top row, and m black and k white particles in the bottom row is $\frac{\ell+1}{n+1} \binom{n+1}{k} \binom{n+1}{m}$.*

PROOF. The statement is verified using the cycle lemma (see [Lot99, Ch. 11], or [Sta99, Ch. 5]). Let $p = k + m$ and denote by $\Delta_p^{\ell+1}$ the set of configurations with p black and $p + 2\ell + 2$ white particles distributed between two rows of $n + 1$ cells. Then the cardinality of the subset $\Delta_{k,m}^{\ell+1}$ of elements of $\Delta_p^{\ell+1}$ that have k black particles in the top row and the other m in the bottom row is $\binom{n+1}{k} \binom{n+1}{m}$. In such a configuration the number of white particles exceeds by $2\ell + 2$ that of black particles, so that $E(n+1) = -2\ell - 2$. Given $\omega \in \Delta_{k,m}^{\ell+1}$, let $d = \min(E(j))$ be the depth of ω , and set $j_i = \min\{j \mid E(j) = d + 2i\}$, for $i = 0, \dots, \ell$. By construction, these $\ell + 1$ columns are $|\circ/\circ|$ -columns. On the one hand, let $\bar{\Delta}_{k,m}^{\ell+1}$ be the set of pairs (ω, j) where $\omega \in \Delta_{k,m}^{\ell+1}$ and $j \in \{j_0, \dots, j_\ell\}$, so that $|\bar{\Delta}_{k,m}^{\ell+1}| = \binom{n+1}{k} \binom{n+1}{m} \cdot (\ell + 1)$. On the other hand, define the set $\bar{\Omega}_{k,m}^{\ell+1}$ of pairs (ω', i) where ω' is obtained from an element of $\Omega_{k,m}^\ell$ by adding a final $|\times|$ -column, and $i \in \{0, \dots, n\}$. By construction, $|\bar{\Omega}_{k,m}^{\ell+1}| = |\Omega_{k,m}^\ell| \cdot (n + 1)$.

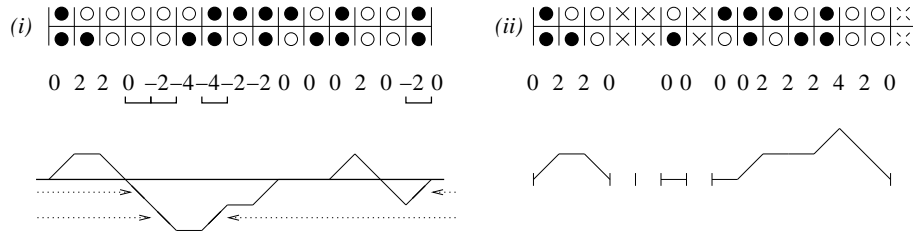

FIGURE 17. From (i) an element of $\bar{\Gamma}_{n+1}$, to (ii) one of Ω_n . The $(B(j) - W(j))_{j=0..n+1}$ are given under both configurations and graphically represented.

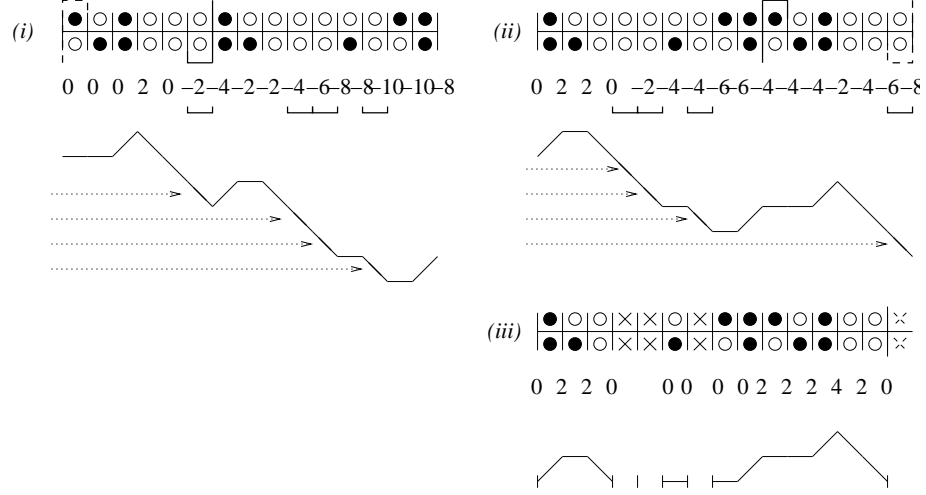

FIGURE 18. (i) An element of $\bar{\Delta}_{k,m}^{\ell+1}$ (with $\ell = 3$ and column $j = 6$ colored), (ii) its conjugate (with column $n + 1 - j$ colored), and (iii) the corresponding element of $\bar{\Omega}_{k,m}^{\ell}$. The sequence $(B(j) - W(j))_{j=0..n+1}$ is given under each configuration and graphically represented.

The proof of the lemma consists in a bijection ϕ between $\bar{\Delta}_{k,m}^{\ell+1}$ and $\bar{\Omega}_{k,m}^{\ell+1}$ (see Figure 18). Given $(\omega, j) \in \bar{\Delta}_{k,m}^{\ell+1}$, let ω_1 denote the first j columns of ω , and ω_2 the $n+1-j$ others. Then by construction of j , the concatenation $\omega_2|\omega_1$ satisfies $E(i) > -2\ell - 2$ for $i = 1, \dots, n$, and $E(n+1) = -2\ell - 2$. This implies that $\omega_2|\omega_1$ decomposes as a sequence $\omega'_0, \omega'_1, \dots, \omega'_\ell$ of $\ell + 1$ (possibly empty) blocks that satisfy the positivity constraint, each followed by a $|\circ|$ -column. Let ω' be obtained by replacing these $\ell + 1$ $|\circ|$ -columns by $|\times|$ -columns. Then the map $(\omega, j) \rightarrow (\omega', n+1-j)$ is a bijection of $\bar{\Delta}_{k,m}^{\ell+1}$ onto $\bar{\Omega}_{k,m}^{\ell+1}$: the inverse bijection is readily obtained by first replacing the $|\times|$ -columns into $|\circ|$ -columns, and then recovering the factorization $\omega_2|\omega_1$ from the fact that ω_2 has $n+1-j$ columns. \square

LEMMA 2.3. *The number $|\Omega_p^\ell|$ of complete configurations of Ω_n , for $p+\ell = n$, with ℓ $|\times|$ -columns, and p black and p white particles distributed between the two rows is $\frac{\ell+1}{n+1} \binom{2n+2}{p}$.*

PROOF. The proof uses the same arguments than the proof of Lemma 2.2. The only difference is that, instead of counting elements of $\Delta_{k,m}^{\ell+1}$ with k black particles in the top row and m in the bottom row, we count elements of $\Delta_p^{\ell+1}$, that have a total of p black particles. Hence the previous factor $|\Delta_{k,m}^{\ell+1}| = \binom{n+1}{k} \binom{n+1}{m}$ is replaced by $|\Delta_p^{\ell+1}| = \binom{2n+2}{p}$. \square

Remark. As already said, when $\ell = 0$ we have configurations with just two kinds of particles. In this case, from Lemma 2.2 and Lemma 2.3, we have $|\Omega_{k,m}^0| = \frac{1}{n+1} \binom{n+1}{k} \binom{n+1}{m}$ and $|\Omega_n^0| = \frac{1}{n+1} \binom{2n+2}{n}$.

Lemma 2.4. *The number $|\hat{\Omega}_{k,m}^\ell|$ of configurations of $|\hat{\Omega}_n|$ having ℓ $|\times|$ -columns, k black particles at the top, and m at the bottom is $\binom{n}{k} \binom{n}{m}$.*

PROOF. Recall that $\Delta_{k,m}^\ell$ denote configurations of length n with k black and $m+\ell$ white particles in the top row, and m black and $k+\ell$ white particles in the bottom row, so that $|\Delta_{k,m}^\ell| = \binom{n}{k} \binom{n}{m}$. In order to prove the statement of the lemma we show that $\Delta_{k,m}^\ell$ and $\hat{\Omega}_{k,m}^\ell$ are in bijection. Let $\delta \in \Delta_{k,m}^\ell$, and consider its depth $d = \min(E(i))$ and the ℓ columns $j_i = \min\{j \mid E(j) = d + 2i\}$, $i = 0, \dots, \ell-1$, as in the proof of Lemma 2.3. By definition of these columns, the positivity condition is satisfied by each block between two of them. Moreover, by definition of j_0 and $j_{\ell-1}$, the positivity

condition is also satisfied by the concatenation $\omega_\ell|\omega_0$ of the final block ω_ℓ and the initial block ω_0 . Hence transforming the columns j_0, \dots, j_ℓ into $|\times|$ -columns, and arranging the two rows in a circle by fusing walls 0 and n at the apex yields a configuration $\phi(\delta)$ of $\widehat{\Omega}_{k,m}$ (recall that these configurations are not considered up to rotation). Conversely, given ω in $\widehat{\Omega}_{k,m}$, a unique element δ of $\Delta_{k,m}^\ell$ such that $\phi(\delta) = \omega$ is obtained by opening at the apex and transforming $|\times|$ -columns into $|\circ|$ -columns. \square

Appendix B. A complete example

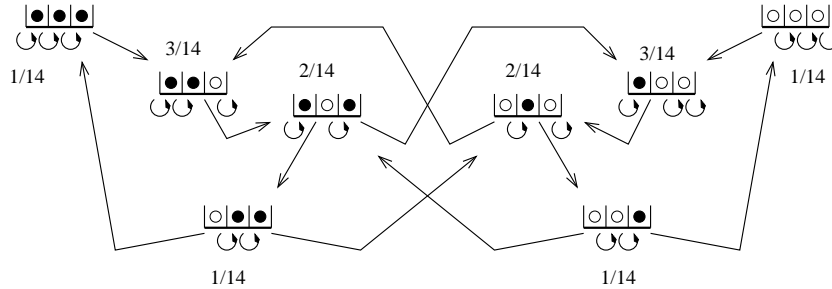

FIGURE 19. The basic configurations for $n = 3$ and transitions between them. The starting point of each arrow indicates the wall triggering the transition. The numbers are the stationary probabilities.

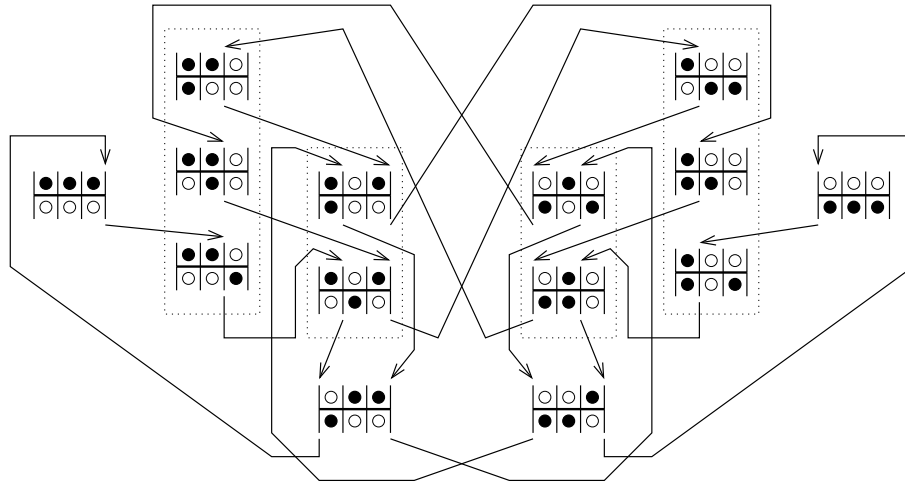

FIGURE 20. The 14 complete configurations for $n = 3$ and transitions between them. The starting point of each arrow indicates the wall triggering the transition (loop transitions are not indicated). Stationary probabilities are uniform (equal to $1/14$) since each configuration has equal in and out degrees. Ignoring the bottom rows reduces this Markov chain to the chain of Figure 19.

CAMS, EHESS, 52 BD RASPAIL, 75006 PARIS, FRANCE
E-mail address: Enrica.Duchi@ehess.fr

LIX, CNRS, ÉCOLE POLYTECHNIQUE, 91128 PALAISEAU, FRANCE
E-mail address: Gilles.Schaeffer@lix.polytechnique.fr