



**HAL**  
open science

## Selection and identification of physical parameters from passive observation. Application to a winding process

Thierry Bastogne, Magalie Thomassin, John Masse

### ► To cite this version:

Thierry Bastogne, Magalie Thomassin, John Masse. Selection and identification of physical parameters from passive observation. Application to a winding process. *Control Engineering Practice*, 2007, 15 (9), pp.1051-1061. 10.1016/j.conengprac.2006.12.006 . hal-00149963

**HAL Id: hal-00149963**

**<https://hal.science/hal-00149963v1>**

Submitted on 29 May 2007

**HAL** is a multi-disciplinary open access archive for the deposit and dissemination of scientific research documents, whether they are published or not. The documents may come from teaching and research institutions in France or abroad, or from public or private research centers.

L'archive ouverte pluridisciplinaire **HAL**, est destinée au dépôt et à la diffusion de documents scientifiques de niveau recherche, publiés ou non, émanant des établissements d'enseignement et de recherche français ou étrangers, des laboratoires publics ou privés.

# Selection and identification of physical parameters from passive observation.

## Application to a winding process

T. Bastogne <sup>a,\*</sup>, M. Thomassin <sup>b</sup>, J. Masse <sup>c</sup>

<sup>a</sup>*Centre de Recherche en Automatique de Nancy (CRAN)*

*Nancy - Université, CNRS UMR 7039,*

*BP 239, F-54506 Vandœuvre-lès-Nancy Cedex, France,*

*Phone: (33) 3 83 68 44 73 - Fax: (33) 3 83 68 44 62*

<sup>b</sup>*Laboratoire d'Automatique, Productique et Signal (LAPS)*

*UMR 5131 CNRS, Université Bordeaux 1*

*ENSEIRB 351 cours de la libération*

*33405 Talence Cedex - France*

<sup>c</sup>*Appedge, 18-22 rue d'Arras 92000 Nanterre, France*

---

### Abstract

This paper deals with parameter selection and estimation of large and complex simulation models. This estimation problem is addressed in the case of passive observation, *i.e.* when no controlled experiment is possible. Given the lack of information in the data, an appropriate methodology is proposed to select and estimate some physical parameters of the model. Its implementation is based on a new software: Diffedge<sup>©</sup> which makes it possible to symbolically determine model output sensitivity functions of block diagrams. An application to a winding prototype is developed

to illustrate the effectiveness of such an approach in practice. <sup>1</sup>

---

<sup>1</sup> Control Engineering Practice, doi:10.1016/j.conengprac.2006.12.006

*Key words:* identifiability, parameter selection, parameter identification, sensitivity analysis, limited experimentation, winding system

---

## 1 Introduction

There are three kinds of mathematical models of dynamic processes: (i) white-box models based on first principles of physics, and sufficiently detailed to contain the representations of individual components (Maciejowski, 1997), (ii) black-box models based on generic model structures, *e.g.* linear, for the design of feedback controllers (Ljung, 1987) and (iii) grey-box models, a sort of compromise between the two boxes previously mentioned, *i.e.* a black-box model in which a part of the underlying physics is available and taken into account in the identification procedure (Bohlin, 1991). This article deals with the parameter estimation of white-box models. The term 'calibration' is also widely used to express the determination of a parameter set, usually from observed data, and thus provide the 'best' representation of the system being modelled. It is generally a misused term. Indeed, calibration means the adjustment in comparison to a standard, *i.e.* a noise free reference. In practice, data are noisy and the calibration process corresponds in fact to parameter estimation. Herein, the estimation problem is addressed in the case of passive observation, *i.e.* when no input design can be applied to the process because of economic or safety reasons (Thomassin *et al.*, 2003). For an engineer with extensive ex-

---

\* Corresponding author.

*Email addresses:* `thierry.bastogne@cran.uhp-nancy.fr` (T. Bastogne),  
`magalie.thomassin@lag.ensieg.inpg.fr` (M. Thomassin),  
`john.masse@appedge.com`, <http://www.appedge.com> (J. Masse).

perience with a specific model, manual calibration of a white-box model could probably be sufficient to some applications. However, manual adjustment of such complex models is usually time-consuming, and its results are not often reproducible. For these reasons a great effort has been devoted to the development of automatic methods in parameter estimation. Approaches like those proposed by Isaksson *et al.* in (Isaksson *et al.*, 2003) for the estimation of physical parameters are not appropriate to passive data since they require to carry out three dedicated experiments. Calibration tools of grey-box models like MoCaVa (Bohlin, 2003) cannot be applied either. Its principle consists in recursively fitting and testing a series of model structures. Sub-models which do not contribute to significantly reduce the overall loss are eliminated from consideration, while those which do contribute are candidates for further refinements. In the case of a white-box model, its resolution, *i.e.* the number of physical parameters, is fixed. Its internal structure is imposed and no model reduction is possible. In such a case, the estimation problem is twofold:

- checking the uniqueness of the solution given the passive data, *i.e.* assessing the practical identifiability (Dochain and Vanrolleghem, 2001);
- given the number of identifiable parameters, selecting those which can be estimated using the passive data.

Using a general approach, Vanrolleghem *et al.* have proposed in (Vanrolleghem *et al.*, 1995; Weijers and Vanrolleghem, 1997; Dochain and Vanrolleghem, 2001) have suggested to both assess the practical identifiability and select the most identifiable parameters. This article presents three types of contribution:

- the relationship between the practical identifiability (Dochain *et al.*, 1995; Dochain and Vanrolleghem, 2001) and the output distinguishability (Grewal

and Glover, 1976) is firstly emphasized;

- a new selection mode of the most identifiable parameters is proposed;
- and a new implementation solution is applied to this approach, based on a new software: Diffedge<sup>©</sup> which makes it possible to symbolically determine model output sensitivity functions of block diagrams.

This paper is composed of three major sections. The identification problem is stated in Section 2. The identification procedure is presented in Section 3 and an application study to a winding process is developed in Section 4, in order to illustrate the effectiveness of the proposed approach.

## 2 Problem statement

Consider a dynamical system described by an implicit differential-algebraic model structure  $\mathcal{M}(\Theta, x_0)$  defined by

$$\begin{cases} f(\dot{x}(t, \Theta), x(t, \Theta), u(t), \Theta, t) = 0 \\ y_m(t, \Theta, x_0, u) = h(x(t, \Theta), u(t), \Theta, t) \end{cases} \quad (1)$$

where

$$\begin{aligned} f &: \mathbb{R}^n \times \mathbb{R}^n \times \mathbb{U} \times \mathbb{P} \times \mathbb{T} \rightarrow \mathbb{R}^n \\ h &: \mathbb{R}^n \times \mathbb{U} \times \mathbb{R}^+ \times \mathbb{P} \rightarrow \mathbb{R}^l, \end{aligned} \quad (2)$$

$x(t, \Theta) \in \mathbb{R}^n$ ,  $y(t, \Theta) \in \mathbb{R}^l$ ,  $\Theta \in \mathbb{P}$  and  $u(t) \in \mathbb{U}$ .  $\mathbb{P}$  and  $\mathbb{U}$  are two open sets in  $\mathbb{R}^p$  and  $\mathbb{R}^q$  respectively.  $\mathbb{T}$  is a set of time instants defined by  $\mathbb{T} = \{t_j\}$ ,  $j = 0, \dots, N-1$ .  $N$  is the number of data points,  $p$  is the number of parameters and  $q, l, n$  are the numbers of input, output and state variables respectively.

$x$ ,  $u$ ,  $y$  and  $\Theta$  represent the state, the input, the output and the parameters of the model respectively.  $x_0 = x(t_0, \Theta)$  is the fixed known initial state.  $\mathcal{M}(\Theta, x_0)$  and  $\Theta$  are supposed to be structurally distinguishable and structurally identifiable respectively (Walter and Pronzato, 1997). Now suppose that a data set  $\{u(t), y(t)\}$ , with  $t \in \mathbb{T}$ , resulting from one experiment, is available. The classical parameter identification problem consists in determining  $\Theta$  by extracting information from observed data ( $u$  and  $y$ ). Contrary to this standard problem, it is assumed herein that the nominal values of  $\Theta$  and their uncertainty are available. However, by answering the investigated question, remains to know if whether or not the available data  $\{u, y\}$  may be used to re-estimate some physical parameters of the model. The associated underlying problem is the selection of parameters to estimate. An identification procedure is developed in the sequel in order to answer these last two questions.

### 3 Identification methodology

Table 1 sums up some notations used in the sequel. The identification procedure, described in figure 1, is composed of six steps. The prior analysis starts by determining the nominal values of the model parameters. The latter are either directly measured or empirically estimated by experts as initial values. Secondly, the prior uncertainty of the parameters is evaluated. This task is crucial but much more laborious. Therefore, it is often subject to expert knowledge and modeling experience. To keep the cost of this step reasonably low, Brun *et al.* in (Brun *et al.*, 2002) have suggested to introduce two different classes of relative uncertainty: accurately known parameters (class 1) and vaguely known parameters (class 2). Consequently  $\Theta$  is split up into two

Notation	Content
$\Theta^*$	complete list of system parameters
$\Theta$	complete list of model parameters
$\Theta_i$	$i^{th}$ parameter of $\Theta$
$\Theta_i^*$	'true' value of $\Theta_i$
$\overline{\Theta}$	well known parameters
$\underline{\Theta}$	poorly known parameters
$\overline{\theta}$	set of identifiable parameters
$\underline{\theta}$	set of non identifiable parameters
$\overline{p}$	most identifiable parameters
$\underline{p}$	less identifiable parameters
$\hat{p}$	estimated parameters

Table 1

#### Parameters notation

parts:  $\Theta = [\overline{\Theta}, \underline{\Theta}]$  corresponding to the two different classes of parameters: accurately and vaguely known (parameters) respectively. The third step is devoted to the implementation of the model into a simulation environment. In this approach, the simulation model is represented by a block-diagram implemented into Simulink<sup>©</sup>. The 4<sup>th</sup> step deals with the practical identifiability of the model structure, using the collected data  $\{u, y\}$ . Knowing the number of identifiable parameters, gathered in  $\overline{\theta}$ , a subvector  $\overline{p}$  is selected in the 5<sup>th</sup> step.  $\overline{p}$  contains the most identifiable and less correlated parameters given  $\{u, y\}$ .  $\overline{p}$



is finally used in the 6<sup>th</sup> step to initialize the parameter estimation step. The estimation criterion is defined as follows

$$\hat{p} = \arg \min_{\bar{p}} J(\Theta, x_0, u) \quad \bar{p} \subset \Theta \quad (3)$$

$$J(\Theta, x_0, u) = \sum_{j=0}^{N-1} e(t_j, \Theta, x_0, u)^T Q e(t_j, \Theta, x_0, u)$$

where  $e(t_j, \Theta, x_0, u) = y_s(t_j, \Theta^*, x_0, u) - y_m(t_j, \Theta, x_0, u)$  denotes the output error between the system output  $y_s$  and the model  $y_m$ .  $Q$  is a weighting diagonal matrix.  $\Theta^*$  is the vector of system parameters. To facilitate reading,  $x_0$  and  $u$  have been omitted thereafter.

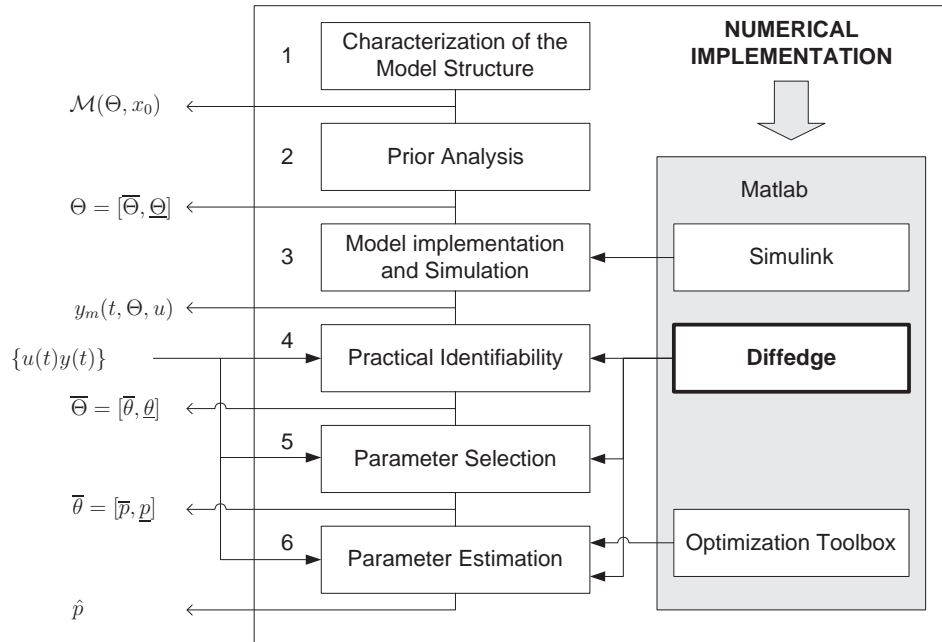

Figure 1. Parameter identification procedure

### 3.1 Practical identifiability

Structural identifiability (Walter and Pronzato, 1997) deals with the possibility to give a unique value to each parameter of a mathematical model structure. The uniqueness of this solution is assessed in an idealized or theoretical

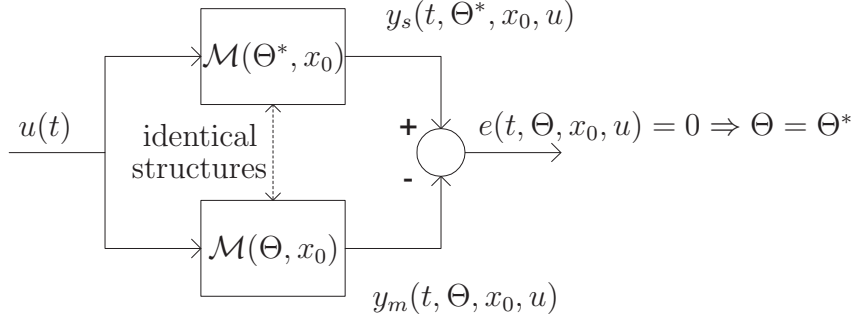

Figure 2. Structural identifiability condition

framework where the process and the model have identical structures, the data are noise-free, and where the input signals and the measurement times can be chosen at will, *c.f.* figure 2. Given these conditions, a parameter  $\Theta_i$  of  $\Theta$  is globally identifiable for almost any  $\Theta^* \in \mathbb{P}$  if

$$\mathbb{B}_{\mathcal{M}}(\Theta) \equiv \mathbb{B}_{\mathcal{M}}(\Theta^*) \Leftrightarrow \Theta_i = \Theta_i^* \quad \forall i \in \{1, \dots, p\} \quad (4)$$

The behavioral set  $\mathbb{B}_{\mathcal{M}}(\Theta)$  of the model structure  $\mathcal{M}$  corresponds to the set of the admissible time trajectories of the model variables (Willems, 1991).  $\mathbb{B}_{\mathcal{M}}(\Theta)$  is defined by

$$\mathbb{B}_{\mathcal{M}}(\Theta) = \left\{ t, \Theta, \begin{pmatrix} y(t) \\ u(t) \end{pmatrix} \middle| \exists x(t) : y(t, \Theta) = \mathcal{M}(t, \Theta, x, u) \right\}$$

However,  $\mathbb{B}_{\mathcal{M}}(\Theta)$  is not convenient enough to be used as such. For this reason, it is generally substituted by a simpler function of parameters, called *summary*. In practice, a non exhaustive summary based on the output time trajectories is often used. The question of the structural identifiability can then be approached by the notion of output distinguishability defined in (Grewal and Glover, 1976) by :

$$y(t, \Theta, \mathcal{E}) = y(t, \Theta^*, \mathcal{E}) \Rightarrow \Theta_i = \Theta_i^*, \quad (5)$$

for an infinite collection of experiments  $\mathcal{E} = \{(x_0, u(\cdot)), u(\cdot) \in \mathcal{U}\}$  within which an experiment is defined as a pair  $(x_0, u(\cdot))$ .  $\mathcal{U}$  denotes a set of piecewise continuous functions  $\mathbb{R}^+ \rightarrow \mathbb{U}$ .

However, in practice, experimental conditions are often subjected to economical and/or security constraints. These industrial constraints can sometimes prevent input design from being applied to the process. In such a case, the estimation datasets are collected from passive observations, *e.g.* under normal operating conditions (Thomassin *et al.*, 2003). Even if a parameter is globally or locally structurally identifiable, it may not be so in practice, due to a lack of information in the passive data. For that reason, D. Dochain and P. Vanrolleghem, in (Vanrolleghem *et al.*, 1995; Dochain and Vanrolleghem, 2001), have introduced the notion of practical identifiability. The practical identifiability includes the quality of the data. The main question of the structural and practical identifiability analysis can then be formulated as follows (Dochain *et al.*, 1995): *'Assume that a certain number of state variables are available for measurements; on the basis of the model structure (theoretical identifiability) or on the basis of the type and quality of available data (practical identifiability), can we expect to obtain unique values for the model parameters?'*

In fact, the practical identifiability is a particular case of the output distinguishability (Grewal and Glover, 1976) where the experiment  $\mathcal{E} = (x_0, u(\cdot))$  is given. Then, a sufficient condition for the practical identifiability can be stated as follows: given a parametric model structure  $\mathcal{M}$  with a given input  $u(t)$  and the initial conditions  $x_0$  (one experiment),

$$y(t, \Theta, x_0, u(t)) = y(t, \Theta^*, x_0, u(t)) \Rightarrow \Theta_i = \Theta_i^*, \quad (6)$$

$\forall i \in \{1, \dots, p\}$ ,  $t \in \mathbb{T}$ ,  $\Theta \in V(\Theta^*) \subset \mathbb{P}$  and  $y(t, \Theta, x_0, u) = \mathcal{M}(t, \Theta, x_0, u)$ .

If  $d\Theta \in V(\Theta^*)$  with  $\Theta = \Theta^* + d\Theta$ , then a first-order Taylor expansion of  $y(t, \Theta^* + d\Theta, x_0, u)$  is given by

$$y(t, \Theta^* + d\Theta, x_0, u) \approx y(t, \Theta^*, x_0, u) + \sum_{i=1}^p \frac{\partial y}{\partial \Theta_i} \Big|_{\Theta_i^*} d\Theta_i. \quad (7)$$

$V(\Theta^*)$  denotes a parameter neighbourhood. A local approximation of the practical identifiability condition defined in (6) is then given by

$$\sum_{i=1}^p \frac{\partial y}{\partial \Theta_i} \Big|_{\Theta_i^*} d\Theta_i = 0 \Rightarrow d\Theta = 0, \quad (8)$$

or

$$\sum_{i=1}^p d\Theta_i \cdot S_y(t, \Theta_i^*, x_0, u) = 0 \Rightarrow d\Theta = 0, \quad (9)$$

where  $S_y(t, \Theta_i^*, x_0, u) = \partial y / \partial \Theta_i |_{\Theta_i^*}$  denotes the sensitivity function of the model output  $y$  related to the parameter  $\Theta_i$ . Equation (9) expresses the linear independence of the vectors  $S_y(t, \Theta_i^*) \in \mathbb{R}^m$ . In other terms, given the input  $u$  and the initial condition  $x_0$ , the parameters are locally practically identifiable if the mapping  $S_y(t, \Theta_i^*, x_0, u)$ , from the parameter space to outputs, is one to one (Grewal and Glover, 1976).

Let  $\mathbf{S}_y(\Theta)$  be the matrix of sensitivity functions, defined by

$$\mathbf{S}_y(\Theta) = (\mathbf{S}_y(\Theta_1), \dots, \mathbf{S}_y(\Theta_p)) \quad (10)$$

$$\mathbf{S}_y(\Theta_i)^T = (S_y(t_1, \Theta_i), \dots, S_y(t_N, \Theta_i)), \quad (11)$$

where  $\mathbf{S}_y(\Theta_i) \in \mathbb{R}^{1 \times mN}$  and  $\mathbf{S}_y(\Theta) \in \mathbb{R}^{p \times mN}$ . The practical identifiability can be numerically implemented as a null-rank test of the matrix  $\mathbf{S}_y(\Theta)$ . If the rank of  $\mathbf{S}_y(\Theta)$  is estimated as significantly null then the model is not locally practically identifiable. The rank of  $\mathbf{S}_y(\Theta)$  can be viewed as a practical identifiability degree of a model structure for a given experiment.

### 3.2 Sensivity analysis of block diagrams by computer algebra

Equation (9) also emphasizes the crucial role of sensitivity analysis in the local assessment of the practical identifiability. In (Masse and Cambois, 2003), a new symbolic approach which eliminates the drawbacks of the finite-difference approximations and the complexity of the automatic differentiation is proposed and implemented into a software: *Diffedge*<sup>©</sup> (<http://www.appedge.com/>). It combines a computer algebra system and block diagrams to compute the derivatives of a Simulink model with respect to its independent parameters. The derivative model is also represented by a block diagram and can be used like any Simulink model.

### 3.3 Parameter selection

Knowing the number of identifiable parameters, it is rarely judicious to estimate a vector of  $\mu$  identifiable parameters directly from the available data set. Indeed, some of these parameters can have just an insignificant and correlated influence on  $J(\Theta)$ . Hence, two classification procedures are proposed to select the most significant and the less correlated parameters before starting the estimation step.

#### 3.3.1 $J$ -sensitivity classification of parameters

The first classification step consists in sorting out the parameters according to their influence on  $J(\Theta)$ . The comparison criterion proposed herein is defined

as follows

$$L(\Theta_i) = |S_J(\Theta_i)| = \left| \frac{\partial J(\Theta)}{\partial \Theta_i} \right|, \quad (12)$$

where  $S_J(\Theta_i)$  denotes the sensitivity function of  $J(\Theta)$  with respect to the model parameter  $\Theta_i$ . Finally, the J-sensitivity classification consists in sorting out the parameters into a descending order of  $L$ .

### 3.3.2 Correlation classification of parameters

In the second step, parameters are ranked according to the cross-correlation of their sensitivity functions. This correlation classification of the parameters is implemented by sorting out the vectors  $\mathbf{S}_J(\Theta_i) \in \mathbb{R}^N$  in an increasing order of collinearity. The latter is estimated by the smallest singular value of a matrix  $\Sigma \in \mathbb{R}^{N \times \mu}$  where  $\mu$  is the number of identifiable parameters.  $\Sigma$  is iteratively built up from its first column  $\Sigma_1 = S_J(\Theta_{Lmax})$  such that

$$\Theta_{Lmax} = \arg \max_{\Theta_i} L(\Theta_i) \quad i \in \{1, \dots, \mu\}. \quad (13)$$

In other words,  $\Sigma$  is initialized by the sensitivity function of the most influent parameter on  $J$ , i.e.  $S_J(\gamma_3)$  in this case. The other columns of  $\Sigma$  are chosen among the remaining sensitivity functions and are arranged in such an order that

$$\Sigma_j = S_J(\check{\Theta}_i) \quad \text{with:} \quad (14)$$

$$\check{\Theta}_i = \arg \max_{\Theta_i} \sigma_{min}(\Sigma_{1,j}(\Theta_i)) \quad \forall \Theta_i \neq \Theta_{Lmax} \quad (15)$$

and  $j \in \{2, \dots, \mu\}$ .  $\Sigma_j$  denotes the  $j^{th}$  column of  $\Sigma$  and  $\Sigma_{1,j}(\Theta_i) = [\Sigma_1, \dots, \Sigma_{j-1}, S_J(\Theta_i)]$ .

Hence,  $\Sigma_j$  is selected among a given number of sensitivity functions in order to maximize the smallest singular value of  $\Sigma_{1,j}$ . The final arrangement of the

sensitivity functions is described by a spectrum of the smallest singular values of  $\Sigma_{1,j}$  with respect to  $j$ . The correlation classification of the parameters is finally obtained by the x-axis of this spectrum.

Do note that these two classification procedures are valid around a nominal value of  $\Theta$ . That implies repeating them each time the parameters are modified. To avoid weighing down the procedure, it is proposed to check the final classification at the end of the estimation step with the new values of  $\Theta$ .

### 3.4 Parameter estimation

In this section, a bottom-up estimation procedure is proposed. It starts by a small subset of regressors noted  $\bar{p}_0$  resulting from the previous selection step. The estimation step is then repeated by adding parameters according to their rank in the J-sensitivity classification. The final estimates are chosen according to a compromise between complexity (number of parameters) and performance (estimation cost  $J$ ).

## 4 Application to a winding process

Winding systems are in general continuous, multivariable and non-linear processes. They are encountered in a wide variety of industrial plants such as rolling mills in the steel industry (Parant *et al.*, 1992; Walker and Wyatt-Mair, 1995), plants involving web conveyance (Sievers *et al.*, 1988; Ebler *et al.*, 1993; Braatz *et al.*, 1996; Laroche and Knittel, 2005; Benlatreche *et al.*, 2006) including coating, papermaking and polymer film extrusion processes. A laboratory winding process is described in figure 3. The mechanical

part of this prototype is composed of a plastic web and three reels, respectively called unwinding, pacer and rewinding reels. Each reel is coupled with a DC-motor via gear reduction. The angular speed of each reel ( $\Omega_1, \Omega_2, \Omega_3$ ) and both tensions between the reels ( $T_1, T_3$ ) are measured by tachometers and tension meters. At a second level, each motor is connected to a local controller composed of one or two proportional-integral (PI) controllers. The first control loop adjusts the motor current ( $I_1, I_2, I_3$ ) while the second loop controls the angular speed. The setpoints of those controllers ( $I_1^*/\Omega_1^*, \Omega_2^*, I_3^*/\Omega_3^*$ ) are computed by a programmable logic controller (PLC) in order to control both tensions and the linear velocity of the strip.

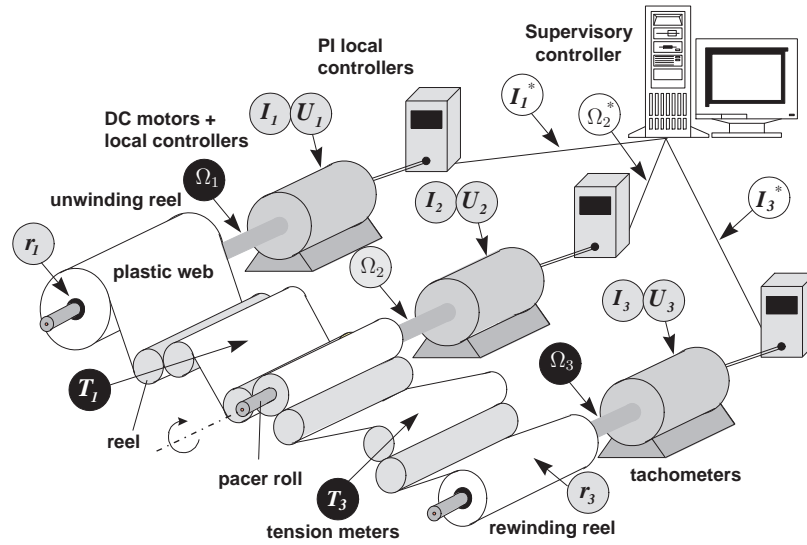

Figure 3. Mechatronic system: winding prototype

In this application, the estimation dataset has been collected at a nominal operating point, where the setpoints of the tension and speed controllers are kept constant. The measurements of the tensions are shown in figure 10.



#### 4.1 White-box model

Physical modeling of winding systems has already been developed in (Bastogne *et al.*, 1998), (Koç *et al.*, 2002). It generally leads to a non linear and continuous-time model structure  $\mathcal{M}(\Theta)$  in which  $\Theta$ , defined in table 2, is a vector composed of 31 physical parameters. The indices 1, 3 denote two parameters: one for the unwinder and the other one for the rewinder. State, output and input variables are noted respectively:  $x$ ,  $y$  and  $u$ , and are defined as follows:

$$y_m(t, \Theta, x_0, u) = \mathcal{M}(t, \Theta, x_0, u) \quad (16)$$

with

$$\begin{aligned} x(t) &= \begin{pmatrix} \varepsilon_1(t) & \varepsilon_2(t) & \varepsilon_3(t) & r_1(t) & r_3(t) & T_1(t) & \dots \\ \dots & T_3(t) & \Omega_1(t) & \Omega_3(t) & \Omega_2(t) & J_1\Omega_1(t) & J_3\Omega_3(t) \end{pmatrix} \\ y(t) &= \begin{pmatrix} T_1(t) & T_3(t) \end{pmatrix} \\ u(t) &= \begin{pmatrix} I_1^*(t) & \Omega_2^*(t) & I_3^*(t) \end{pmatrix} \end{aligned} \quad (17)$$

The outputs are the upstream and downstream tensions of the strip and the inputs are the current and speed setpoints of the DC-motors. The state vector is composed of the error variables of the controllers, the radii of the winders, the tensions, the angular speeds and the angular momentums.

#### 4.2 Prior analysis

The results of the prior analysis are gathered in table 3. Columns 2 and 3 show the nominal values of the model obtained from measurement and empirical

$\Theta_i$	parameters
$E$	Young's modulus
$\epsilon$	thickness of the strip
$\lambda$	width of the strip
$\rho$	density of the strip
$l$	distance between the reels axes
$r_p$	radius of the pacer roll
$r_s$	radius of the driving shaft
$R$	resistance of the armature circuit
$K_\phi$	constant of the DC-motor
$Ti_{1,3}$	integral time constant of the current controller
$Ti_2$	integral time constant of the speed controller
$\eta$	speed reduction coefficient
$R_S$	shunt resistance
$\gamma_{1,3}$	gain of tension meters
$J_p$	moment of inertia of the pacer roll
$J_s$	moment of inertia of the driving shaft
$k_{W1,3}$	calibration gain of the controllers
$G_{1,3}$	gain of the power stages
$\mathcal{T}_{fs1,3}$	dry friction torque
$c_{v1,3}$	viscous friction coefficient
$BP_{1,3}$	proportional band of the current controllers
$BP_2$	proportional band of the speed controller
$\beta_{1,3}$	gain of the dynamometers

Table 2

List of physical parameters:  $\Theta$

estimation respectively. The prior uncertainty of the parameters is indicated in columns 5 and 6 by their uncertainty interval and uncertainty class (1 for accurately known parameters and 2 for vaguely known parameters). The class-2 group, *i.e.* the group of vaguely known parameters noted  $\bar{\Theta}$ , is *a priori*

$\Theta_i$	Nominal value		Unit	Uncertainty	
	Meas.	Emp.		Interval	cl.
$E$	3e7		$N/m^2$	$\pm 1 \cdot 10^9$	1
$\epsilon$	2e-4		$m$	$\pm 5\%$	1
$\lambda$	5e-2		$m$	$\pm 10^{-3}$	1
$\rho$	1350		$Kg/m^3$	$\pm 50$	1
$l$	650e-3		$m$	$\pm 1e - 2$	1
$r_p$	3.5e-2		$m$	$\pm 2e - 3$	1
$r_s$	1.5e-2		$m$	$\pm 2e - 3$	1
$R$	5		$\Omega$	$\pm 1\%$	1
$K_\phi$	0,75		$Vs$	$\pm 0.1$	1
$Ti_{1,3}$	40e-3		$s$	Small	1
$Ti_2$	200e-3		$s$	Small	1
$\eta$	10.4			Small	1
$R_S$	0.1		$\Omega$	Small	1
$\gamma_{1,3}$	0.1		$V/N$	Large	1
$J_p$		2e-3	$Kgm^2$	Large	2
$J_s$		2e-3	$Kgm^2$	Large	2
$k_{W1,3}$		0.1	$\%/V$	Large	2
$G_{1,3}$		2	$V/\%$	Large	2
$\mathcal{T}_{fs1,3}$		0.5	$Nm$	Large	2
$c_{v1,3}$		1e-2	$Nms$	Large	2
$BP_{1,3}$		100	$\%$	Large	2
$BP_2$		100	$\%$	Large	2
$\beta_{1,3}$		0.1	$Vs/rad$	Large	2

Table 3

Values of physical parameters

composed of 17 elements. However, according to experts,  $BP_2$  does not have any significative influence on  $T_1$  and  $T_3$  and has, consequently, been removed

from  $\bar{\Theta}$ . Now the remaining and investigated question is, whether or not, some parameters of  $\bar{\Theta}$  can be estimated from the available dataset.

### 4.3 Model implementation

The component-based model of the winding process is described by a block diagram shown in figure 4 and implemented into Simulink<sup>®</sup>. Its simulation has been carried out by an ordinary differential equations solver proposed by (Shampine and Reichelt, 1997). The initial values of the states have been measured.

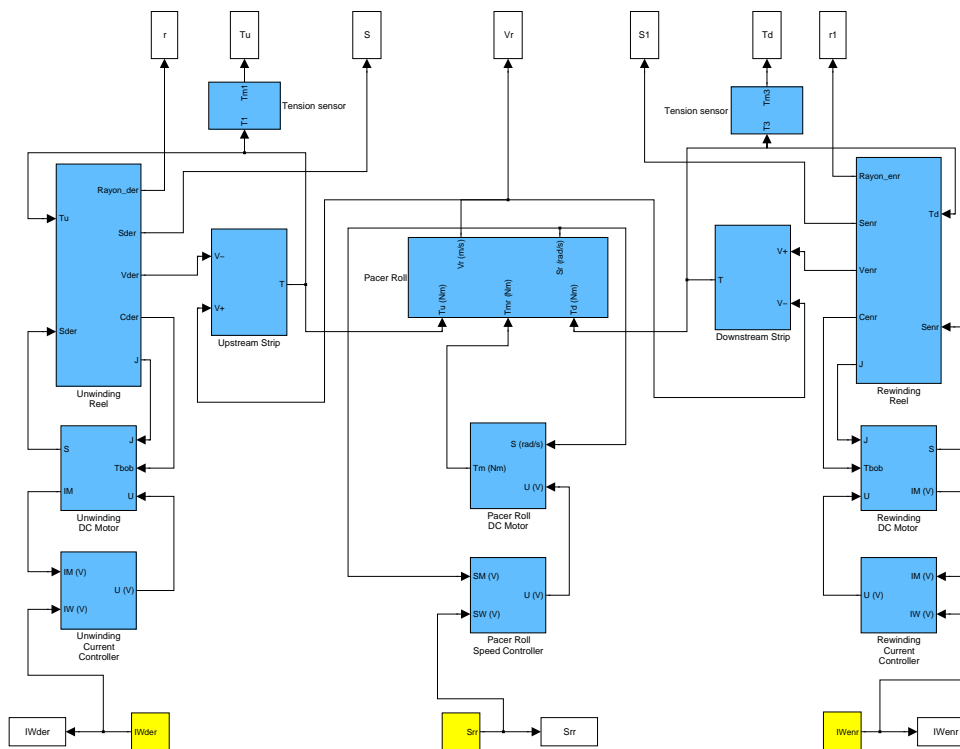

Figure 4. Simulink model of the winding system

#### 4.4 Practical identifiability

Figure 5 shows the sensitivity functions of the tension  $T_3$  with respect to the 16 parameters gathered in  $\bar{\Theta}$ . These sensitivity functions have been estimated by *Diffedge*. In each subfigure, two sensitivity functions are represented: the symbolic derivatives in solid lines and the numeric (finite differences) derivatives in dotted lines. These two functions are generally similar and this similarity corroborates their validity. The differences appearing between the symbolic and numeric sensitivity functions for  $\mathbf{S}_{T_3}(J_p)$ ,  $\mathbf{S}_{T_3}(BP_1)$  and  $\mathbf{S}_{T_3}(BP_3)$  are due to a wrongly chosen step in the computation of the finite differences. The nu-

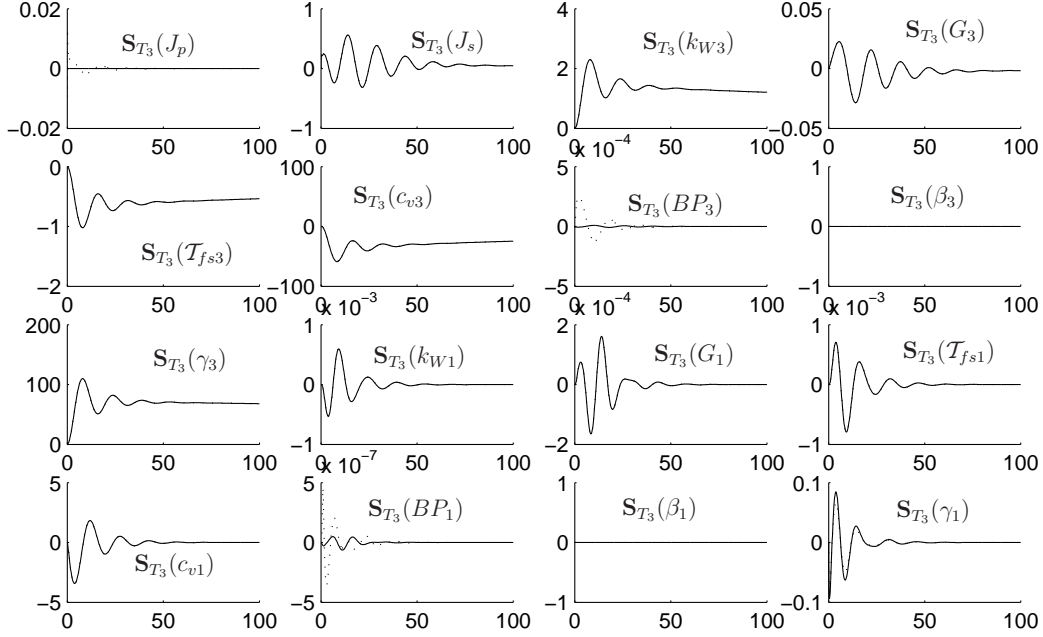

Figure 5. Sensitivity functions of  $T_3$  (numeric estimates in dotted lines and symbolic estimates in solid lines), the units on the x-axis correspond to the time (s)

merical rank of  $\mathbf{S}_y(\bar{\Theta})$  is equal to 14. The 14 practically identifiable parameters are:

$$\bar{\theta} = (\gamma_1, \gamma_3, J_p, J_s, k_{W1}, k_{W3}, G_1, G_3, T_{fs1}, T_{fs3}, c_{v1}, c_{v3}, BP_1, BP_3) \quad (18)$$

$\beta_1$  and  $\beta_3$  are not identifiable due to their null sensitivity functions for  $T_1$  and  $T_3$ . Indeed,  $\beta_1$  and  $\beta_3$  are the gains of the dynamometers, and consequently have no relationship with the tensions.

#### 4.5 Parameter selection

##### 4.5.1 J-sensitivity selection

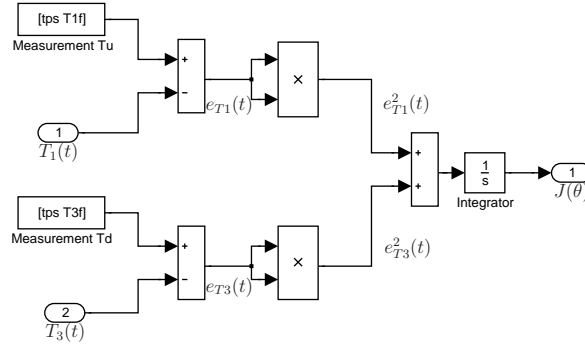

Figure 6. Implementation of the estimation cost function

The implementation of the J-sensitivity classification procedure requires the determination of the sensitivity functions  $S_J(\Theta_i)$ . The estimation cost function  $J(\Theta)$  has been implemented into a bloc diagram with Simulink, *c.f.* figure 6, and its sensitivity functions have been computed with *Diffedge*. Results are presented in figure 7. It is shown that  $\gamma_3$  is the most significant parameter, whereas  $J_p$  is the less significant parameter, in the sense of the maximization of  $L$ .

##### 4.5.2 J-sensitivity selection

Figure 8 shows the spectrum of the smallest singular values of  $\Sigma_{1,j}$  with respect to  $j$ . The correlation classification of the parameters is given by the x-axis of this spectrum. It is shown that the first four parameters of the J-sensitivity

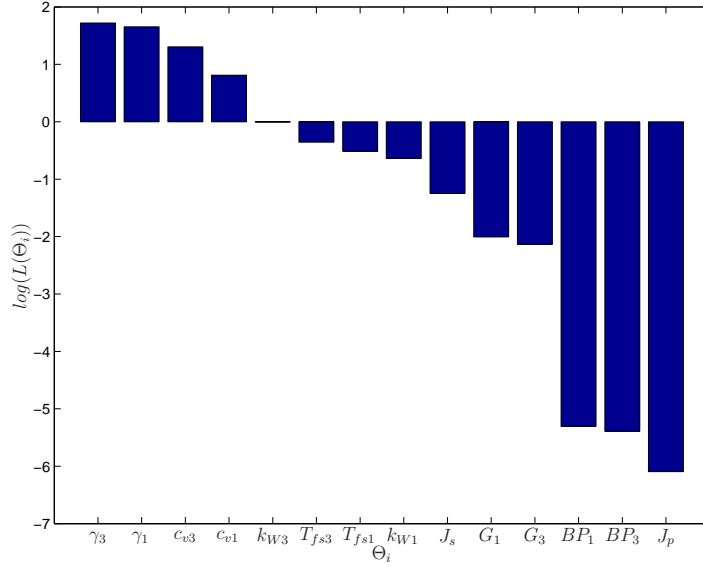

Figure 7. J-sensitivity classification results

classification are also the same ones as the first four parameters of the correlation classification. Consequently, the subset  $(\gamma_3, \gamma_1, c_{v3}, c_{v1})$  is proposed to initialize the estimation process.

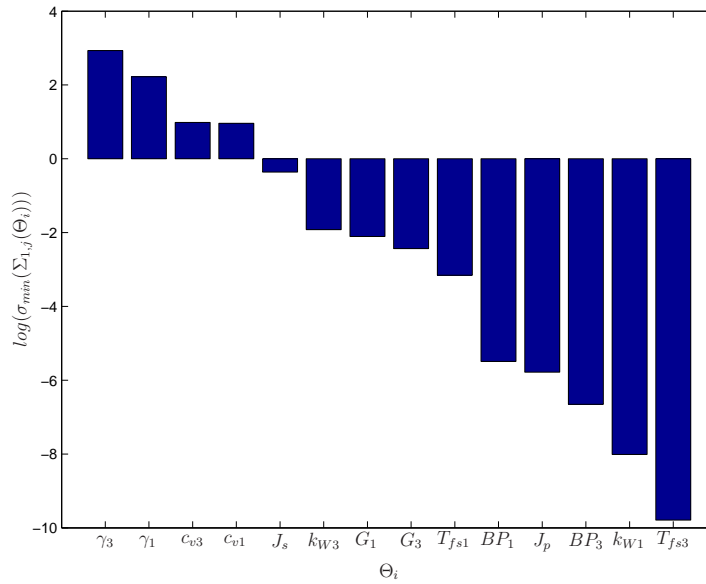

Figure 8. Smallest singular value spectrum of  $\Sigma_{1,j}$

#### 4.6 Parameter estimation

An initial set of regressors noted  $\bar{p}_0 = (\gamma_3, \gamma_1, c_{v3}, c_{v1})$  has been obtained in the previous selection step. The optimization algorithm used to solve  $J(\theta)$  is based on a reflective Newton method devoted to the minimization of a quadratic function subject to bounds on the variables (Coleman and Li, 1996). *Diffedge* has also been used at this level to determine the symbolic gradient of  $J(\theta)$  and given as an input data of the optimization algorithm.

#### 4.7 Results analysis

Figure 9 shows the evolution of the estimation cost function with respect to the parameters. The x-axis denotes the parameters included in  $\bar{p}$  starting from  $\gamma_3$ . The best result is obtained with:  $p^T = (\gamma_3, \gamma_1, c_{v3}, c_{v1})$  and corroborates the proposition stated at the end of the previous section. Beyond  $c_{v1}$  the cost function is quasi-constant. In other terms, the other parameters do not significantly contribute to reducing the estimation error. The estimates of  $\gamma_3, \gamma_1, c_{v3}, c_{v1}$  are presented in table 4 and the estimated outputs are shown in figure 10. The uncertainty on each estimate is not developed herein but a few techniques are proposed in (Walter and Pronzato, 1997; Dochain and Vanrolleghem, 2001).

$p_i$	$\gamma_3$	$\gamma_1$	$c_{v3}$	$c_{v1}$
$\hat{p}_i$	3.98e-3	3.19e-3	7.66e-3	9.36e-3

Table 4

Estimation results



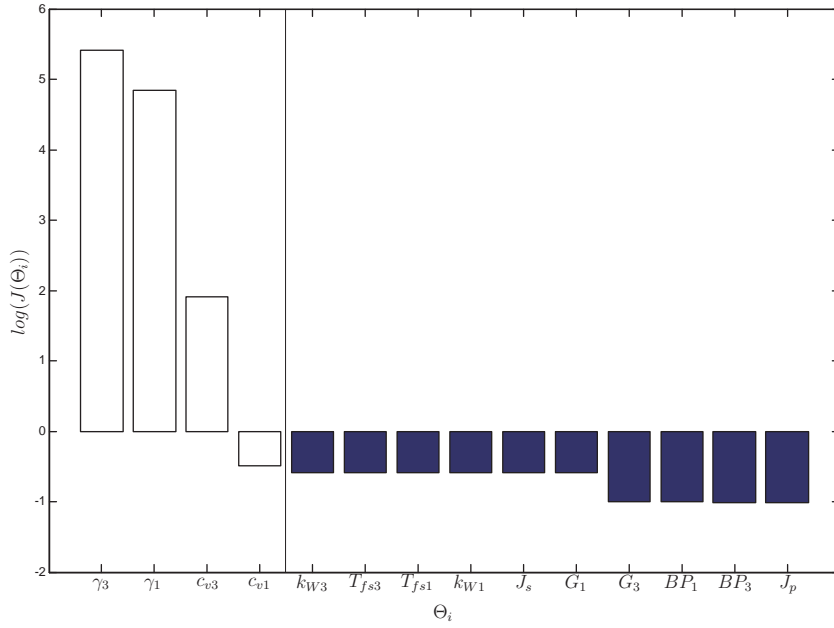

Figure 9. Spectrum of the estimation cost function  $J(\Theta)$

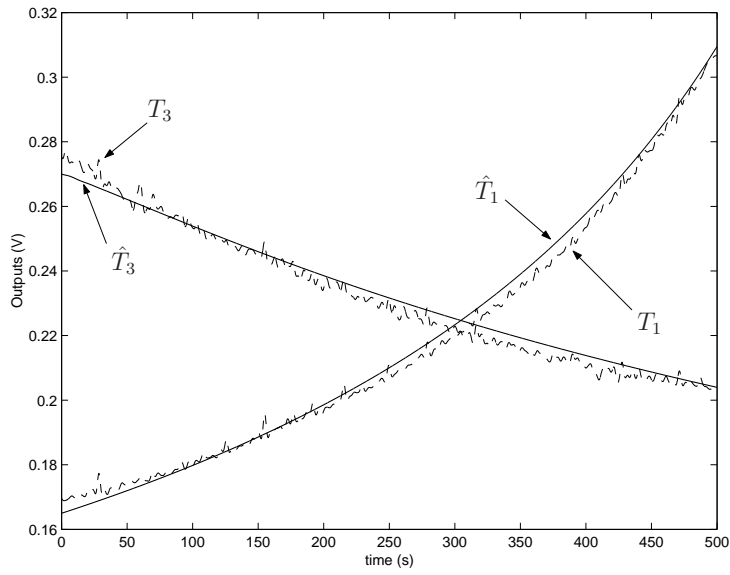

Figure 10. Estimated outputs (full line) after parameter estimation and measured outputs (dotted line)

## 5 Conclusion

This article deals with parameter selection and estimation of large and complex simulation models in the case of passive observation, *i.e.* when no con-

trolled experiment is possible. The estimation problem is twofold: checking the uniqueness of the solution given the passive data, *i.e.* examining the practical identifiability and selecting the most identifiable parameters to initialize the estimation step. Three types of contribution are presented: (i) the relationship between practical identifiability and output distinguishability is firstly emphasized; (ii) a new selection mode of the most identifiable parameters is proposed; and (iii) a new tool, Diffedge<sup>®</sup>, is applied to the problem of sensitivity analysis. This software makes it possible to symbolically determine the model output sensitivity functions of block diagrams. An application to a winding process is developed in the second part of the paper to illustrate the applicability of such an approach in practice.

## References

- Bastogne, T., H. Noura, P. Sibille and A. Richard (1998). Multivariable identification of a winding process by subspace methods for tension control. *Control Engineering Practice* **6**(9), 1077–1088.
- Benlatreche, A., D. Knittel and E. Ostertag (2006). Robust decentralised control strategies for large-scale web handling systems. *Control Engineering Practice*. doi:10.1016/j.conengprac.2006.03.003.
- Bohlin, T. (1991). *Interactive System Identification: Prospects and Pitfalls*. Springer Verlag.
- Bohlin, T. (2003). Grey-box model calibrator and validator. In: *13th IFAC Symposium on System Identification*. Rotterdam, Netherland.
- Braatz, R. D., B. A. Ogunnaike and A.P. Featherstone (1996). Identification, estimation and control of sheet and film processes. In: *Proc. of the 13th Triennial*

*IFAC World Congress*. San Francisco. pp. 319–324.

Brun, R., M. Kühni, H.R. Siegrist, W. Gujer and P. Reichert (2002). Practical identifiability of ASM2d parameters - systematic selection and tuning of parameter subsets. *Water Research* **36**(16), 4113–4127.

Coleman, T. F. and Y. Li (1996). A reflective newton method for minimizing a quadratic function subject to bounds on some of the variables. *SIAM Journal on Optimization* **6**(4), 1040–1058.

Dochain, D. and P. Vanrolleghem (2001). *Dynamical Modelling and Estimation in Wastewater Treatment Processes*. IWA Publishing.

Dochain, D., P.A. Vanrolleghem and M. Van Daele (1995). Structural identifiability of biokinetic models of activated sludge respiration. *Water Res.* **29**, 2571–2579.

Ebler, N. A., R. Arnason, G. Michaelis and N. D'Sa (1993). Tension control : Dancer rolls or load cells. *IEEE Trans. on Industry applications* **29**(4), 727–739.

Grewal, M. S. and K. Glover (1976). Identifiability of linear and nonlinear dynamical systems. *IEEE Trans. on Automatic Control* **21**(6), 833–837.

Isaksson, A.J., R. Lindkvist, X. Zhang, M. Nordin and M. Tallfors (2003). Identification of mechanical parameters in drive train systems. In: *13th IFAC Symposium on System Identification*. Rotterdam, Netherland.

Koç, H., D. Knittel, M. de Mathelin and G. Abba (2002). Modeling and robust control of winding systems for elastic webs. *IEEE Trans. on Control Systems Technology* **2**(10), 197–208.

Laroche, E. and D. Knittel (2005). An improved linear fractional model for robustness analysis of a winding system. *Control Engineering Practice* **13**(5), 659–666.

- Ljung, L. (1987). *System Identification: Theory For The User*. Prentice Hall. Englewood Cliffs, NJ.
- Maciejowski, J. M. (1997). Reconfigurable control using constrained optimization. In: *Proc. of the 4th European Control Conference*. Vol. Plenary Lectures and Mini-Courses. Brussels, Belgium. pp. 107–130.
- Masse, J. and T. Cambois (2003). Diffedge: Differentiation, sensitivity analysis and identification of hybrid models. In: *Réunion Française des Utilisateurs de Logiciels dédiés à la Modélisation et au Calcul Scientifique*. Institut Français du Pétrole, Rueil-Malmaison, France.
- Parant, F., C. Coeffier and C. Iung (1992). Modeling of web tension in a continuous annealing line. *Iron and Steel Engineer* pp. 46–49.
- Shampine, L. F. and M. W. Reichelt (1997). The MATLAB ODE suite. *SIAM J. Sci. Comp* (18), 1–22.
- Sievers, L., M. J. Balas and A. Von Flotow (1988). Modeling of web conveyance systems for multivariable control. *IEEE Trans. on Automatic Control* **33**(6), 524–531.
- Thomassin, M., T. Bastogne, A. Richard and A. Libaux (2003). A bayesian approach for time-delay estimation of a managed river reach in imposed experimental conditions. In: *3rd IFAC Workshop on Linear Time-Delay Systems*. Rocquencourt, France.
- Vanrolleghem, P.A., M. Van Daele and D. Dochain (1995). Practical identifiability of a biokinetic model of activated sludge respiration. *Wat. Res.* **29**(11), 2561–2570.
- Walker, Jr. N. D. and G. F. Wyatt-Mair (1995). Sensor signal validation using analytical redundancy for an aluminium cold rolling mill. *Control Eng. Practice* **3**(6), 753–760.

- Walter, E. and L. Pronzato (1997). *Identification of Parametric Models from experimental data*. Springer-Verlag, Masson.
- Weijers, S.R. and P. A. Vanrolleghem (1997). A procedure for selecting best identifiable parameters in calibrating activated sludge model no.1 to full-scale plant data. *Wat. Sci. Tech.* **36**(5), 69–79.
- Willems, J. C. (1991). Paradigms and puzzles in the theory of dynamical systems. *IEEE Transactions on Automatic Control* **36**(3), 259–294.