



HAL
open science

Rewritings for Polarized Multiplicative and Exponential Proof Structures

Christophe Fouqueré, Virgile Mogbil

► **To cite this version:**

Christophe Fouqueré, Virgile Mogbil. Rewritings for Polarized Multiplicative and Exponential Proof Structures. *Electronic Notes in Theoretical Computer Science*, 2008, pre-proceedings version, 203 (1), pp. 109-121. 10.1016/j.entcs.2008.03.037 . hal-00143929

HAL Id: hal-00143929

<https://hal.science/hal-00143929>

Submitted on 28 Apr 2007

HAL is a multi-disciplinary open access archive for the deposit and dissemination of scientific research documents, whether they are published or not. The documents may come from teaching and research institutions in France or abroad, or from public or private research centers.

L'archive ouverte pluridisciplinaire **HAL**, est destinée au dépôt et à la diffusion de documents scientifiques de niveau recherche, publiés ou non, émanant des établissements d'enseignement et de recherche français ou étrangers, des laboratoires publics ou privés.

Rewritings for Polarized Multiplicative and Exponential Proof Structures

(rapport interne LIPN - Février 2007)

Christophe Fouquéré* and Virgile Mogbil*

LIPN – UMR7030, CNRS – Université Paris 13,
99 av. J-B Clément, F-93430 Villetaneuse, France
christophe.fouquere@lipn.univ-paris13.fr
virgile.mogbil@lipn.univ-paris13.fr

Abstract. We study conditions for a concurrent construction of proof-nets in the framework of linear logic following Andreoli's works. We define specific correctness criteria for that purpose. We first study the multiplicative case and show how the correctness criterion given by Danos and decidable in linear time, may be extended to *closed modules* (i.e. validity of polarized proof structures). We then study the exponential case. This has natural applications in (concurrent) logic programming as validity of partial proof structures may be interpreted in terms of validity of a concurrent execution of clauses in an environment.

1 Introduction

Girard in his seminal paper [9] gave a parallel syntax for multiplicative linear logic (MLL) as oriented graphs called *proof-structures*. Let us recall that a MLL formula is either an atomic formula A , a negation of an atomic formula, or built with a binary connective \otimes or \wp . In the original definition, a proof-structure for MLL is constructed by means of the following binary links:

$$\otimes\text{-link: } \begin{array}{c} A \quad B \\ \diagdown \quad / \\ \circledast \\ | \\ A \otimes B \end{array} \quad \wp\text{-link: } \begin{array}{c} A \quad B \\ \diagdown \quad / \\ \circledcirc \\ | \\ A \wp B \end{array} \quad \text{axiom-link: } \begin{array}{c} \frown \\ A \quad A^\perp \end{array}$$

where every occurrence of formula is a premise of at most one link and is a conclusion of exactly one link. A *correctness criterion* enables one to distinguish sequentializable proof-structures (the so called *proof-nets*) from "bad" structures (that do not correspond to proofs in the sequent calculus). After Girard's long trip correctness criterion, numerous equivalent properties were found. In particular, Danos and Regnier [7] proved that *switched* proof-structures should be trees, where switching is done by deleting one of the premises of each \wp -link. Danos [6] showed that it is the case iff the proof structure rewrites to \bullet (\otimes is called a contracted node):

* Partially supported by ACI NIM project Géométrie du Calcul (GEOCAL), France.

$$(1) \quad \otimes \longrightarrow \bullet \quad (2) \quad \begin{array}{c} \bullet \\ | \\ \bullet \end{array} \longrightarrow \bullet \quad (3) \quad \begin{array}{c} \bullet \\ | \\ \textcircled{\otimes} \end{array} \longrightarrow \bullet \quad (4) \quad \begin{array}{c} \bullet \\ | \\ \textcircled{\wp} \end{array} \longrightarrow \bullet$$

While a lot of research has been done on finding efficient correctness criteria for MLL, it still remains to study correctness criteria in case of *polarized* proof-structures in MLL, and broaden it to the exponential case. First used by Andreoli in Logic Programming [1] and also considered in Girard's works [10] and in Laurent's works about Polarized Linear Logic [13], this concept of polarization allows to consider clustered structures. Recently, polarized proof structures arise naturally in logic programming models [2–4]. The basic objects we consider are then proof structures with two strata we call *elementary bipolar modules*, that may be combined into *modules*. We recall the multiplicative case in the following section (the reader may find in [8] extension to open modules). We define a correctness criterion that takes care of the parallel structure of modules, extending the Danos criterion. In section 3, we analyze how modules may be generalized to take care of exponentials.

2 The multiplicative case

We consider in this section the extension MLLu of MLL with 1 the unit of \otimes . Formulae are given as:

$$\begin{aligned} F &:= 1 \mid G \\ G_1, G_2 &:= A \mid A^\perp \quad \text{atomic formula or its negation} \\ &\mid G_1 \otimes 1 \mid 1 \otimes G_1 \mid G_1 \otimes G_2 \mid G_1 \wp G_2 \end{aligned}$$

Let \mathcal{PS}^n be the directed graphs where edges are labelled by formulae of MLLu and built with the following links ($n \geq 1$):

$$\begin{array}{llll} \otimes\text{-link:} & \begin{array}{c} A_1 \quad A_n \\ \textcircled{\otimes} \\ \vdots \\ A_1 \otimes \dots \otimes A_n \end{array} & \wp\text{-link:} & \begin{array}{c} A_1 \quad A_n \\ \textcircled{\wp} \\ \vdots \\ A_1 \wp \dots \wp A_n \end{array} & \text{axiom-link:} & \begin{array}{c} \text{---} \\ \text{A} \quad \text{A}^\perp \end{array} & \text{1-link:} & \begin{array}{c} \textcircled{1} \\ | \\ 1 \end{array} \end{array}$$

possibly with edges pending downwards. Elements of \mathcal{PS}^n are called *proof structures*. Formulae labelling pending edges are the *conclusions* of the proof structure, nodes with pending edges are called *conclusion nodes*. Labels on edges are omitted when clear from the context.

Proposition 1. *Let π be a proof structure of \mathcal{PS}^n , π is a proofnet (i.e. sequentializable) iff $\pi \rightarrow^* \bullet$:*

$$\begin{array}{lll} (1) \quad \begin{array}{c} \textcircled{\otimes} \\ | \\ \bullet \end{array} \longrightarrow \begin{array}{c} \bullet \\ | \\ \bullet \end{array} & (2) \quad \begin{array}{c} \bullet \\ | \\ \textcircled{\otimes} \end{array} \longrightarrow \begin{array}{c} \bullet \\ | \\ \bullet \end{array} & (3) \quad \begin{array}{c} \textcircled{1} \\ | \\ \bullet \end{array} \longrightarrow \bullet \\ (4) \quad \begin{array}{c} \textcircled{\wp} \\ | \\ \bullet \end{array} \longrightarrow \begin{array}{c} \bullet \\ | \\ \bullet \end{array} & (5) \quad \begin{array}{c} \bullet \\ | \\ \textcircled{\wp} \end{array} \longrightarrow \bullet & (6) \quad \begin{array}{c} \textcircled{\wp} \\ | \\ \bullet \end{array} \longrightarrow \bullet \end{array}$$

In case (4), there must exist at least one edge between the two nodes.

The proof of the proposition follows from the standard one on binary proof structures for MLL [6], and the following remarks: \otimes and \wp are associative and commutative, the 1-ary \wp connective is by convention the identity, 1 is a unit for \otimes .

We first give the definition of an *elementary bipolar module* (EBM) and give the correspondence with proof structures. We then define a *module* as the composition of EBMs. A module is correct if the corresponding proof structure is sequentializable.

Definition 1 (EBM). An EBM M is given by a finite set $\mathcal{H}(M)$ of propositional variables (called *hypotheses*) h_i and a non empty finite set $\mathcal{C}(M)$ varying over k of finite sets $\mathcal{C}_k(M)$ of propositional variables (called *conclusions*) c_k^j . Variables are supposed pairwise distinct.¹ The set of propositional variables appearing in M is noted $v(M)$. Equivalently, one can define it as a directed graph with labelled pending edges and two kinds of nodes, one positive pole under a non-empty finite set of negative poles:

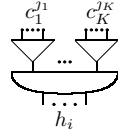

The set of pending edges of an EBM M is called the border $b(M)$.

The proof structure corresponding to an EBM is given by the following transformation on poles. The converse transformation requires the definition of BMs defined later.

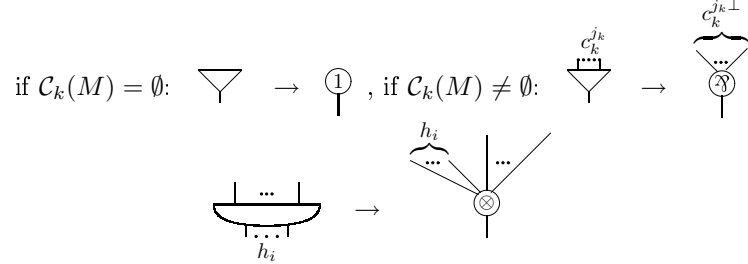

An EBM M may be equivalently defined as a (type) formula $t(M)$ in the dual language of MLLu (recall that $A \multimap B = A^\perp \wp B$): $t(M) = (\otimes_i h_i) \multimap (\wp_k (\otimes_{j_k} c_k^{j_k}))$, where we use the convention that $\wp_k F_k = \otimes_k F_k = F_1$ when the domain of k is of cardinal 1, and if the domain of i is empty, $(\otimes_i h_i) \multimap C = C$ and if the domain of j_k for some k is empty, $(\otimes_{j_k} c_k^{j_k}) = \perp$. However the reader should care that this supposes a bilateral sequent calculus, although the logical

¹ This restriction is taken for simplicity. The framework can be generalized if we consider multisets (of hypotheses and conclusions) instead of sets, and add as required a renaming mechanism: the results in this paper are still true.

reading of an EBM (or of a proof structure) is unilateral. Three kinds of EBMs are of special interest: An EBM is *initial* (resp. *final*) if its set of hypotheses is empty (resp. its set of conclusions is empty). An EBM is *transitory* if it is neither initial nor final. Initial EBMs allow to declare available resources, though final EBMs stop part of a computation by withdrawing a whole set of resources. Transitory EBMs are called definite clauses in standard logic programming.

Definition 2 (BM). A bipolar module (BM) M is defined with hypotheses $\mathcal{H}(M)$, conclusions $\mathcal{C}(M)$, and type $t(M)$, inductively in the following way:

- An EBM is a BM.
- Let M be a BM, and N be an EBM, let $I = \mathcal{C}(M) \cap \mathcal{H}(N)$, their composition wrt the interface I , $M \circ_I N$ is a BM with the multiset of hypotheses $\mathcal{H}(M) \cup (\mathcal{H}(N) - I)$, the multiset of conclusions $(\mathcal{C}(M) - I) \cup \mathcal{C}(N)$, the type $t(M) \otimes t(N)$ and variables $v(M) \cup v(N)$.

The interface will be omitted when it is clear from the context. Note that the interface may be empty. The translation from proof structures of \mathcal{PS}^n to BMs is given by the two following rules, plus rules not explicitated here due to lack of space that take care of polarity and the constant 1:

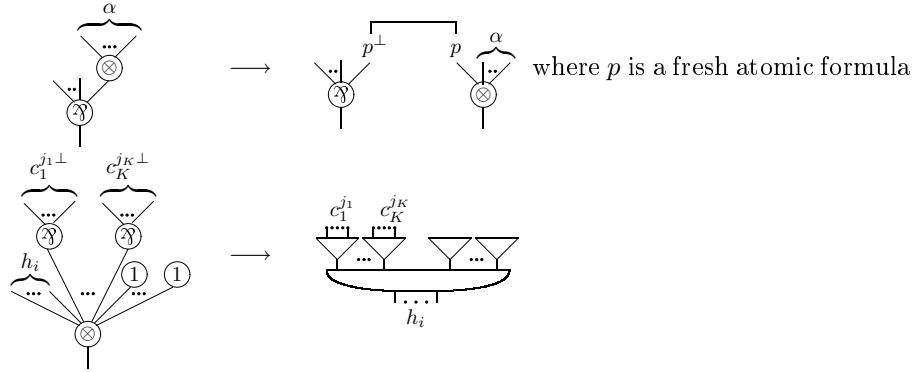

Considering BMs in place of proof structures for MLLu has valuable consequences in terms of simplicity of correctness criteria as one can take care of the bipole structure of BMs more directly than it is the case with a binary structure.

Definition 3 (Correctness (wrt sequentialization)). Let M be a BM, M is correct if the corresponding proof structure in \mathcal{PS}^n is sequentializable.

Sequentialization means that there exists a formula C built with the connectives \otimes and \wp , and the variables $\mathcal{C}(M)$ such that the sequent $\mathcal{H}(M), t(M) \vdash C$ is provable in Linear Logic. Let us briefly interpret EBMs and BMs in terms of computation. An EBM has the following operational bottom-up reading: being given in some context a multiset of hypotheses (data for the positive pole), the EBM triggers once (linear) each of the negative poles, these last have to be used in separate contexts. Triggering an EBM, that is composing it with an existing BM, is nothing else but doing a resolution step in logic programming. However, the resulting BM may not correspond to a valid computation. As we

shall focus on characterizing correctness on closed modules, we adjoin to the term *correct* the kind of modules we speak of, e.g. *c-correct* when the module is closed, *o-correct* in the general setting.

A closed module is a BM without any pending edges, i.e. with the sets of hypotheses and conclusions empty. Correctness of closed modules may be tested either in terms of provability in a sequent calculus or by means of correctness criteria for proof structures. In the following, we consider the correctness criteria of Danos [6] using a contraction relation and explained in the previous section, and also the one given by Danos and Regnier [7] that uses switchings: let π be a proof structure with binary links and $S(\pi)$ the set of (switched) graphs obtained from π by removing exactly one premise edge for each \mathfrak{A} link, π is a proof net iff each graph in $S(\pi)$ is acyclic and connected. One generalizes this definition to n -ary connectives by introducing generalized switches: each n -ary \mathfrak{A} connective induces n switched graphs. One still can define switched proof-structures and a criterion generalizing Danos-Regnier correctness criterion on \mathcal{PS}^n : a proof structure π is a proof net iff the graphs in $S(\pi)$ are acyclic and connected. A closed module M is *DR-correct* if the proof structure M^* associated to M is a proof net wrt the previous criterion. We abusively refer to the module M instead of the corresponding proof structure M^* in the following, speaking of for instance switched module instead of switched proof structure. We immediately have the following proposition as a corollary of the Danos and Regnier criterion theorem:

Proposition 2. *Let M be a closed module, M is *c-correct* iff M is *DR-correct*.*

We give below a (big step) reduction relation that takes care of the *focalization* property. Though a Danos-like relation would reduce each step one variable, our formulation uses as a whole the structure of a module thanks to focalization. The focalization property states that a sequent is provable iff there exists a proof such that decomposition of the positive stratum of formulae is done in one step. Considering bipolar modules, it means that one may define a reduction relation such that each step reduces one positive-negative pair of nodes.

Proposition 3 (Stability). *Let M and N be two closed modules such that $M \rightarrow N$, M is *c-correct* iff N is *c-correct* (see Fig. 1).*

Proof. One can define a function from the switched structures of the module on the left of the relation onto the switched structures associated to the module on the right such that a switched structure from the left is acyclic (resp. connected) iff the corresponding switched structure from the right is acyclic (resp. connected).

Theorem 1 (c-correctness). *A closed module M is *c-correct* iff $M \twoheadrightarrow^* \bigvee_{\square}$.*

Proof. As the reduction rules are stable wrt correctness, it remains to prove that a correct non-terminal closed module M can always be reduced. We define a partial relation on negative poles: a negative pole is smaller than another one if there exists a positive pole such that the first negative pole is linked to

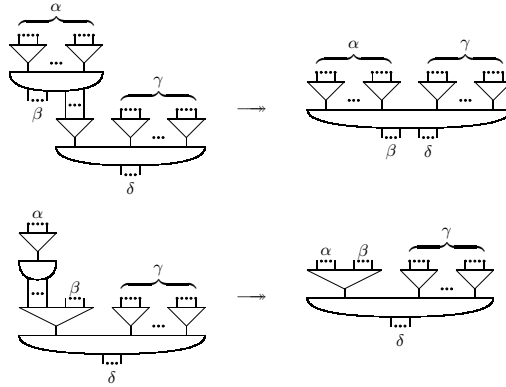

Fig. 1. Big step reduction relation.

the bottom of the positive pole and the second negative pole is linked to the top of the positive pole. We consider the transitive closure of this relation. If maximal negative poles do not exist then there exists at least one cycle in the module alternating positive and negative poles. We can then define a switching function on the module (choosing the correct links for negative poles) such that the switched module has a cycle. Hence contradiction. So let us consider one of the maximal negative pole, and the corresponding positive pole. We remark that such a negative pole has no outgoing links (the module is closed and the negative pole is maximal). If the positive pole has other negative poles, we can omit the maximal negative pole by neutrality. Otherwise, let us study the incoming negative poles. If there is no such incoming link, then M is the terminal module. If each incoming negative pole has at least one link going to another positive pole, then one can define a switching function using for each of these negative poles one of the links that does not go to the positive pole we considered first. Hence the switched module is not connected (there are no outgoing links). Hence contradiction. So there exists at least one incoming negative pole with the whole set of links associated to the positive pole: the first rule applies and we are finished.

Note that this proof extensively uses the bipolar nature of modules. Moreover, the proof may have been given considering minimal poles in place of maximal poles, and for each proof only one of the two reduction rules is sufficient and necessary! Finally, the same technique Guerrini [11] used for Danos criterion may be applied here to get a linear algorithm. Studying correctness of open modules is a necessary step towards the specification of a logic programming language based on bipolar modules. We detailed in another paper the extension of the technique presented before to open modules [8].

3 Dealing with exponentials

3.1 Multiplicative exponential linear logic (MELL)

Adding exponentials to the language obviously increases its expressivity: it allows for representing reusable resources. In linear logic, the 'of course' modality $!$ has this main property: $!A \multimap A \otimes \cdots \otimes A$. Technically, three operations are necessary: *contraction*, *dereliction* and *weakening*. The first operation states that $!A$ is duplicable. Dereliction allows to consider the classical formula $!A$ as the linear one A . The last operation states that $!A$ may be forgotten. The dual modality 'why not' $?$ may be interpreted in the following way: $?A^\perp$ waits for the 'classical' resource $!A$. This *promotion* operation is more complex than the other operations: in terms of proofnets, correctness is assured if a 'box' in the proof net characterizes the context (and this context has to be correct by itself). Entries of such a box are given by one $!$ and a set of $?$.

From MELLu to ?-EBMs. The translation from formulae of MELL to modules is not as easy as it is without exponentials. We consider an extension MELLu of MELL with the neutral element 1 for \otimes , formulae are built from the following grammar:

$$\begin{aligned} F & := 1 \mid G \\ G_1, G_2 & := A \mid A^\perp \mid G_1 \otimes 1 \mid 1 \otimes G_1 \mid G_1 \otimes G_2 \mid G_1 \wp G_2 \mid ?G_1 \mid !G_1 \end{aligned}$$

Converting from formulae to modules requires the use of polarization and focalization. Focalization allows to consider n -ary connectives. Formulae are polarized negatively or positively according to their main connectives, considering conveniently that variables A, B, \dots are positive whereas their negations A^\perp, B^\perp, \dots are negative. A precise study of the exponential connectives leads to the acknowledgment that exponential connectives change the polarity of formulae: if A is a positive formula, $?A$ is negative whereas $!A^\perp$ is positive. Hence exponential connectives may be split into two parts: $!A^\perp = \downarrow \sharp A^\perp$ and $?A = \uparrow \flat A$. The shift connectives \downarrow and \uparrow do the changing of polarities. The introduction of shift connectives may be generalized also to the linear case whenever there is a change of polarity. The two modalities \flat and \sharp express exponentiality.

We consider a slightly different version of a polarized system as it was designed by Boudes [5] or Laurent [13]: the system $\text{LL}_{\text{po}1}$ given by Laurent takes care of multiplicative as well as additive connectives where atomic formulae are always exponentialized. Following our motivations, our language ${}_n\text{MELL}_{\text{po}1}$ is restricted to the multiplicative case for simplicity and atomic formulae may be linear or exponential. Finally we use n -ary connectives and the decomposition of exponentials is explicit. The grammar for ${}_n\text{MELL}_{\text{po}1}$ is given in the following way where the set of formulae is explicitly split into positive (P, \dots) and negative (N, \dots) formulae (A is a positive atomic formula):

$$\begin{cases} P := \bigotimes_{i \in I} \rho_i \mid \flat(\bigotimes_{i \in I} \rho_i) \\ \rho := A \mid \downarrow N \end{cases} \quad \begin{cases} N := \wp_{k \in K} \nu_k \mid \sharp(\wp_{k \in K} \nu_k) \\ \nu := A^\perp \mid \uparrow P \end{cases}$$

We keep as convention that a 1-ary tensor is the identity and a 0-ary tensor is the tensor unit $\mathbf{1}$. Moreover, one can remark that *defining* $\mathbf{1}$ as $\Downarrow\# \top$, where \top is the neutral for the additive connective $\&$, is coherent with our setting and may be useful extending our framework to additives. Nevertheless, in the following, the standard rule for $\mathbf{1}$ is implicitly added to the calculi. One can define a n -ary focalized sequent calculus (A is an atomic formula) as in Fig. 2. Sequents contain a distinguished place between \vdash and $\#$; , they are in one of the two following forms: $\vdash \ ; \ \Gamma$ or $\vdash N \ ; \ \Gamma$ where N is a negative non atomic formula and Γ is a multiset of positive formulae or atomic negative formulae. The sequent calculus is designed such that, beginning with the distinguished place empty, search for proofs consists of repeating the decomposition of a positive formula followed by the decomposition of negative formulae (necessarily subformulae of the positive formula just decomposed), until applying axioms. Note that exponential rules are as possible integrated to linear rules to quotient the search space (e.g. the axiom rule includes (bw) , $(b\otimes)$ manages (bc)). The following translation $(-)^-$ from MELLu to ${}_n\text{MELL}_{\text{po}1}$ is such that if F is a MELLu formula, $\vdash_{\text{MELLu}} F$ is provable iff $\vdash_{{}_n\text{MELL}_{\text{po}1}} F^-$; is provable:

$$\frac{\mathbf{1}^+ = \mathbf{1} \quad \left| \begin{array}{l} A^+ = A \\ A^{\perp -} = A^{\perp} \end{array} \right. \quad \left| \begin{array}{l} (F_1 \otimes F_2)^+ = F_1^+ \otimes F_2^+ \\ (F_1 \wp F_2)^- = F_1^- \wp F_2^- \end{array} \right. \quad \left| \begin{array}{l} (!F)^+ = \Downarrow\# F^- \\ (?F)^- = \uparrow b F^+ \end{array} \right. \quad \left| \begin{array}{l} F^+ = \Downarrow F^- \text{ otherwise} \\ F^- = \uparrow F^+ \text{ otherwise} \end{array} \right.}{}$$

$$\frac{\frac{\frac{\frac{\frac{\frac{\vdash \ ; \ A^{\perp}, A, b\Xi}{\vdash \ ; \ A^{\perp}, A, b\Xi} \text{ (axiom)}}{\vdash \ ; \ A^{\perp}, A, b\Xi} \text{ (1)}}{\vdash \ ; \ \Gamma, A, b\Xi \quad \vdash \ ; \ A^{\perp}, \Delta, b\Xi} \text{ (cut)}}{\vdash \ ; \ \Gamma, \Delta, b\Xi}}{\dots \vdash N_i \ ; \ \Gamma_i, b\Xi \quad \dots \vdash \ ; \ A_j, \Delta_j, b\Xi \quad \dots} \text{ (\otimes)}}{\vdash \ ; \ \otimes_{i \in I} \downarrow N_i \otimes_{j \in J} A_j, \Gamma_1, \dots, \Gamma_{|I|}, \Delta_1, \dots, \Delta_{|J|}, b\Xi} \text{ (\otimes)}}{\dots \vdash N_i \ ; \ b(\otimes_{i \in I} \downarrow N_i \otimes_{j \in J} A_j), \Gamma_i, b\Xi \quad \dots \vdash \ ; \ b(\otimes_{i \in I} \downarrow N_i \otimes_{j \in J} A_j), A_j, \Delta_j, b\Xi \quad \dots} \text{ (b\otimes)}}{\vdash \ ; \ b(\otimes_{i \in I} \downarrow N_i \otimes_{j \in J} A_j), \Gamma_1, \dots, \Gamma_{|I|}, \Delta_1, \dots, \Delta_{|J|}, b\Xi} \text{ (b\otimes)}}{\frac{\frac{\vdash \ ; \ P_1, \dots, P_{|I|}, A_1^{\perp}, \dots, A_{|J|}^{\perp}, \Gamma}{\vdash \ ; \ P_1, \dots, P_{|I|}, A_1^{\perp}, \dots, A_{|J|}^{\perp}, b\Gamma} \text{ (\wp)}}{\vdash \ ; \ P_1, \dots, P_{|I|}, A_1^{\perp}, \dots, A_{|J|}^{\perp}, b\Gamma} \text{ (\# \wp)}}{\vdash \ ; \ \wp_{i \in I} \uparrow P_i \wp_{j \in J} A_j^{\perp} \ ; \ \Gamma} \text{ (\wp)}}{\vdash \ ; \ \#(\wp_{i \in I} \uparrow P_i \wp_{j \in J} A_j^{\perp}) \ ; \ b\Gamma} \text{ (\# \wp)}} \text{ (\# \wp)}$$

Fig. 2. n -ary sequent calculus for ${}_n\text{MELL}_{\text{po}1}$ (0-ary tensor is $\mathbf{1}$).

The final step consists in flattening ${}_n\text{MELL}_{\text{po}1}$ formulae to get modules. Bipolar modules were previously obtained by adding atomic formulae between two strata (say from negative to positive): let P_1, P_2 be positive formulae, N a negative formula, $\vdash P_1 \otimes (N \wp P_2)$ is provable iff $\vdash P_1 \otimes (N \wp Z^{\perp})$, $Z \otimes P_2$ is provable, where Z is a fresh (positive) atomic formula. However this principle cannot be fully applied when exponentials occur: try to flatten the (provable) sequent $\vdash A^{\perp} \wp \uparrow b(B \otimes C)$, $A \otimes \Downarrow\#(B^{\perp} \wp C^{\perp})$. This can be overcome by allowing exponential atomic formulae in the language. These exponential atomic

formulae are noted with \sharp or \flat superscripts: Z^\sharp and Z^\flat are respectively defined as $\downarrow\sharp\uparrow Z$ and $\uparrow\flat\downarrow Z^\perp$. We then consider the translation $(-)^{\circ}$: let \mathcal{C} be a non-empty context (negative or positive), Z is a fresh atomic formula

$$\begin{aligned}\mathcal{C}[\uparrow\otimes_{i\in I}\rho_i]^{\circ} &= \mathcal{C}[Z^\perp]^{\circ}, [Z\otimes_{i\in I}\rho_i]^{\circ} \\ \mathcal{C}[\uparrow\flat\otimes_{i\in I}\rho_i]^{\circ} &= \mathcal{C}[Z^\flat]^{\circ}, [\flat(Z^\sharp\otimes_{i\in I}\rho_i)]^{\circ}\end{aligned}$$

otherwise (i.e. empty context) $P^{\circ} = P, N^{\circ} = \downarrow N$. We still have if F is a MELLu formula, $\vdash_{\text{MELLu}} F$ is provable iff $\vdash_{n\text{MELL}_{\text{po1}}} F^{\circ}$ is provable. We consider now drawings of the following kind we call ?-EBM:

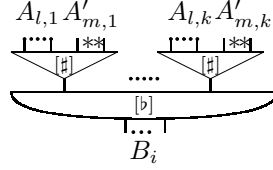

Positive and negative poles may now be labelled: a ?-EBM is reusable when \flat labels its positive part, \sharp labels a promoted variable, brackets mean optional. $*$ labels an exponential atomic negative conclusion of a ?-EBM and we refer to $*$ -edge in that case. Roughly, the correspondence between places of exponentials in formulae and labelled elements is the following one:

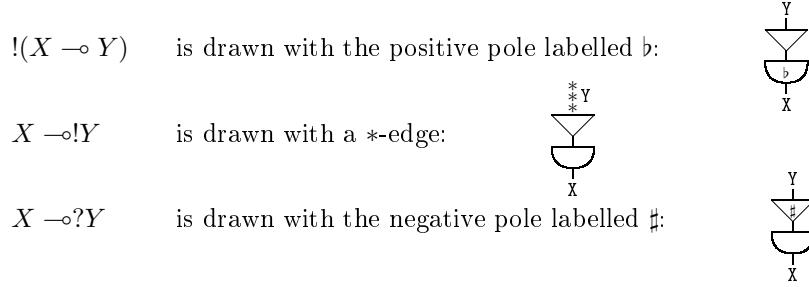

The type of a ?-EBM generalizes the type given for an EBM (brackets mean optional): $\mathbb{C} = [!](\otimes_{i\in I} B_i \multimap \exists_{k\in K} [?](\otimes_{l\in L} A_{l,k} \otimes_{m\in M} Z_{m,k}^\sharp))$. Such a type (*clause* in logic programming terminology) could be interpreted as: \mathbb{C} is a reusable clause iff $!$ is explicit. The application of a clause is allowed if the B_i are available, then one of the conclusions is fired, a conclusion being a multiset of atomic formulae $A_{l,k}$ or exponential, i.e. reusable, atomic formulae $Z_{m,k}^\sharp$. If the $?$ modality is present, the multiset of conclusions is required to be reusable as a whole: not only these conclusions cannot be used with a linear clause but such a clause cannot use linear hypotheses. For example, consider the set of clauses $\{1 \multimap A \otimes B, B \multimap ?C, !(A \otimes C) \multimap \perp\}$. The corresponding module we get is drawn in Fig.3 on the left. The figure on the right is the corresponding proof-structure (see [9, 12] for definitions of proof structures with boxes, extended here to n -ary connectives). The traversal of the box without the use of a \flat -node shows that the sequent is not provable (a dereliction should have been applied), i.e. the ?-EBM on the left is not correct.

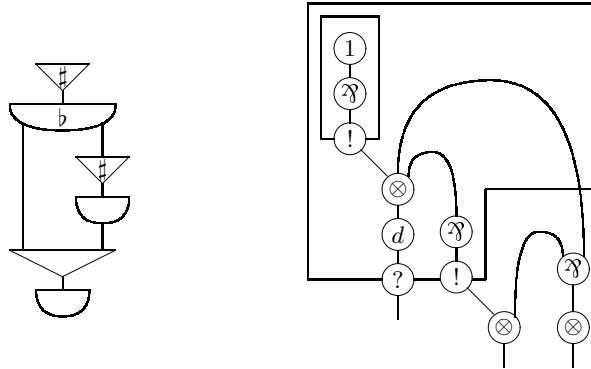
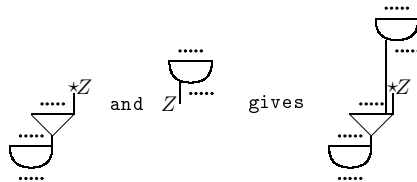

Fig. 3. ?-EBM and proofnets

From ?-EBMs to modules. Definitions given in section 2 for EBM, that is to say composition and correctness of modules, cannot be straightforwardly extended to the exponential case. Obviously, composition should satisfy identification of variables occurring on links, noticing that $*$ -edges can only be linked to $*$ -edges. However, contraction needs a special attention. For the following, we consider explicit contraction: ?-EBMs with positive nodes labelled b , and $*$ -edges are duplicated if necessary mimicking the property $!A \multimap !A \otimes A$, hence the degree of edges is always 1. The definition of composition given in section 2 is then adapted consequently for ?-EBMs labelled b and $*$ -edges. For example, $*$ -edges are duplicated as follows:



It is then possible to define the type $t(M)$ of a module M as the formula given as the Par of the formulae occurring as ?-EBMs taking care of possible contractions. Moreover, it is possible to recover a proof-structure M^* (with, as usual, contraction, weakening and dereliction nodes) from a given module M . Finally, a module is *c-correct* if M^* is a proofnet.

3.2 ?-EBMs and corresponding correctness criteria

Extending the language with exponentials yields a major difficulty due to the promotion rule, as it is inherently contextual. Note that allowing b in the language (and exclude \sharp) is sufficient to embed the framework of the previous sec-

tions in a programming language: one can consider a program as a set of (exponential, reusable) EBMs along with a multiset of (linear, usable once) EBMs. This system already extends classical logic programming in a straightforward way and correctness of modules is tested with the same reduction relation given in previous section, after deleting $*$ -edges (application of the weakening rule) and by considering that normal forms may contain $?$ -EBMs. We consider for the full language the reduction system given by the following two rules:

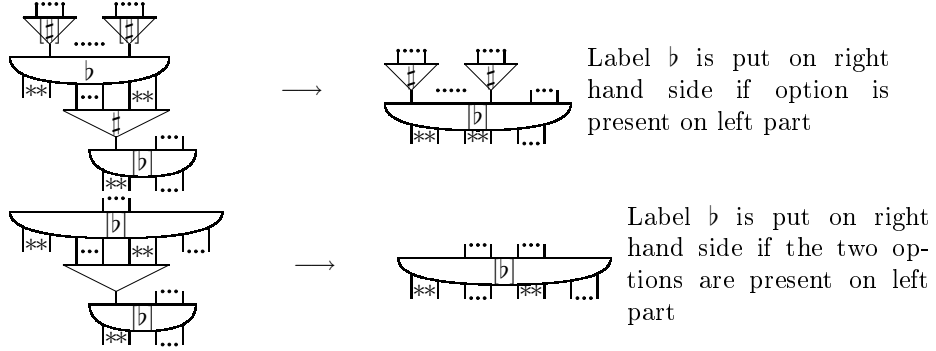

Propositions equivalent to the ones given for the multiplicative case may be proved. Obviously, if M is a closed correct module in this fragment then the module $forget(M)$ built from M forgetting exponentials (omitting labels and replacing $*$ -edges by normal edges) is a closed correct BM. We must also characterize normal forms. We add to the reduction system two rules corresponding to neutrality of $\mathbf{1}$ and weakening of b :

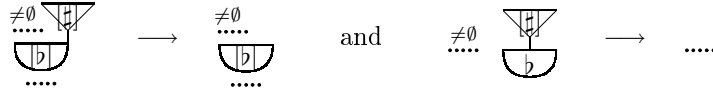

Proposition 4 (Stability). *Let M and N be two closed modules such that $M \rightarrow N$. The module M is c -correct iff N is c -correct.*

Proof. One can define a function from left switched module onto right switched module such that the relation and its inverse are stable wrt acyclicity, connectedness.

Theorem 2. *A closed module M is c -correct iff $M \rightarrow \mathbf{1}$ or $M \rightarrow \mathbf{b}$.*

Proof. The proof used for the linear case is adapted here. As the reduction rules are stable wrt correctness, it remains to prove that a correct non-terminal closed module M can always be reduced. We define a partial relation on negative poles: a negative pole is smaller than another one if there exists a positive pole such that the first negative pole is linked to the bottom of the positive pole and the second negative pole is linked to the top of the positive pole. We consider the transitive closure of this relation. If maximal negative poles do not exist then

there exists at least one cycle in the $forget(M)$ module alternating positive and negative poles. We can then define a switching function on this module (choosing the correct links for negative poles) such that this switched module has a cycle. Hence contradiction. So let us consider one of the maximal negative poles, and the corresponding positive pole. We remark that such a negative pole has no outgoing links (the module is closed and the negative pole is maximal). If the positive pole has other negative poles, we can omit the maximal negative pole by neutrality. Otherwise, let us study the incoming negative poles: (1) If there is no such incoming link, then M is the terminal module. (2) If each incoming negative pole has at least one link a going to another positive pole as in the following figure:

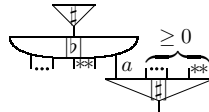

then one can define a switching function using for each of these negative poles one of the link that does not go to the positive pole we considered first. Hence the $forget(M)$ switched module is not connected (there are no outgoing links). Hence contradiction. (3) Else there exists at least one incoming negative pole α with the whole set of links associated to the positive pole: the reduction rules apply and we are finished or this positive pole is linearly linked with b to a negative pole β . Such β is not $\#$ -marked otherwise it corresponds to a proof-structure with an exponential box with two principal ports, hence contradiction. The reduction rules apply to β (and then to α) or there exists a link c from β to another positive pole as in the following figure:

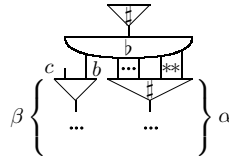

then one can define a switching function using the c link but not b : the corresponding switched proof-structure contains an unconnected component in the exponential box induced by the ($\#$ -marked) α negative. Hence contradiction. This holds because the α links are all linear or none are linear. (4) Finally, there exists at least one incoming negative pole α with the whole set of links associated to the positive pole itself not linearly linked: the reduction rules apply.

Corollary 1. *If F is a provable formula then there exists a c -correct (closed) module M such that $t(M) = F$.*

4 Conclusion

We first adapt the classical rewriting criterion of Danos to the n -ary bipolar case for testing the correctness of closed modules. We show in particular that polarization greatly simplifies the rewriting procedure. We extend our results to the

exponential case. In particular, we give a local criterion for testing correctness of modules in presence of exponentials. Note that current criteria presupposes that 'boxes' are already given, although our reduction relation helps to discover it. These results may be useful in designing concurrent logic programming languages, in the style suggested by Andreoli in recent papers, as it extends his works by removing constraints on programming objects.

References

1. Andreoli, J.-M., *Logic programming with focusing proofs in linear logic.*, J. Log. Comput. **2** (1992), pp. 297–347.
2. Andreoli, J.-M., *Focussing and proof construction*, Annals of Pure and Applied Logic **107** (2001), pp. 131–163.
3. Andreoli, J.-M., *Focussing proof-net construction as a middleware paradigm*, in: A. Voronkov, editor, *CADE*, Lecture Notes in Computer Science **2392** (2002), pp. 501–516.
4. Andreoli, J.-M. and L. Mazaré, *Concurrent construction of proof-nets*, in: M. Baaz and J. A. Makowsky, editors, *CSL*, Lecture Notes in Computer Science **2803** (2003), pp. 29–42.
5. Boudes, P., *Projecting games on hypercoherences.*, in: J. Díaz, J. Karhumäki, A. Lepistö and D. Sannella, editors, *ICALP*, Lecture Notes in Computer Science **3142** (2004), pp. 257–268.
6. Danos, V., “Une application de la logique linéaire à l’étude des processus de normalisation (principalement de λ -calcul),” Ph.D. thesis, Université Denis Diderot, Paris 7 (1990).
7. Danos, V. and L. Regnier, *The structure of multiplicatives*, Archive for Mathematical Logic **28** (1989), pp. 181–203.
8. Fouqueré, C. and V. Mogbil, *Rewritings in polarized (partial) proof structures*, in: F. L. Paola Bruscoli and J. Stewart, editors, *1st Workshop on Structures and Deductions*, Technical Report **ISSN 1430-211X** (2005), pp. 95–109.
9. Girard, J.-Y., *Linear logic*, Theoretical Computer Science **50** (1987), pp. 1–102.
10. Girard, J.-Y., *On the unity of logic.*, Ann. Pure Appl. Logic **59** (1993), pp. 201–217.
11. Guerrini, S., *Correctness of multiplicative proof nets is linear*, in: *Logic in Computer Science*, 1999, pp. 454–463.
URL citeseer.ist.psu.edu/guerrini99correctness.html
12. Lafont, Y., *From proof-nets to interaction nets*, in: J.-Y. Girard, Y. Lafont and L. Regnier, editors, *Advances in Linear Logic*, London Mathematical Society Lecture Note **222**, Cambridge University Press, 1995 pp. 225–247, proceedings of the Workshop on Linear Logic, Ithaca, NewYork, June 1993.
13. Laurent, O., *Syntax vs. semantics: a polarized approach*, Theoretical Computer Science **343** (2005), pp. 177–206.