



HAL
open science

Direct Observation of the Photon Suppression of Electronic Shot Noise in a QPC

Eva Zakka-Bajjani, Julien Segala, Fabien Portier, Patrice Roche, Christian
D.C. Glatli, Antonella Cavanna, Yong Jin

► **To cite this version:**

Eva Zakka-Bajjani, Julien Segala, Fabien Portier, Patrice Roche, Christian D.C. Glatli, et al.. Direct Observation of the Photon Suppression of Electronic Shot Noise in a QPC. 2007. hal-00140551v2

HAL Id: hal-00140551

<https://hal.science/hal-00140551v2>

Preprint submitted on 6 Apr 2007 (v2), last revised 22 Apr 2008 (v4)

HAL is a multi-disciplinary open access archive for the deposit and dissemination of scientific research documents, whether they are published or not. The documents may come from teaching and research institutions in France or abroad, or from public or private research centers.

L'archive ouverte pluridisciplinaire **HAL**, est destinée au dépôt et à la diffusion de documents scientifiques de niveau recherche, publiés ou non, émanant des établissements d'enseignement et de recherche français ou étrangers, des laboratoires publics ou privés.

Direct Observation of the Photon Suppression of Electronic Shot Noise in a QPC

E. Zakka-Bajjani, J. Segala, F. Portier,* P. Roche, and D. C. Glattli†
*Nanoelectronic group, Service de Physique de l'Etat Condensé,
CEA Saclay, F-91191 Gif-Sur-Yvette, France*

A. Cavanna and Y. Jin
*Laboratoire de Photonique et Nanostructures CNRS,
Route de Nozay, F-91460 Marcoussis, France*

(Dated: April 7, 2007)

We report on direct measurements of the electronic shot noise of a Quantum Point Contact (QPC) at frequencies ν in the range 4-8GHz. The very small energy scale used ensures energy independent transmissions of the few transmitted electronic modes and their accurate knowledge. Both the thermal energy and the QPC drain-source voltage V_{ds} are comparable to the photon energy at the observation frequency, leading to observation of the shot noise suppression when $V_{ds} < h\nu/e$. The measurements provide the first direct comparison to the high frequency shot noise scattering theory without adjustable parameters.

PACS numbers: 73.23.-b,73.50.Td,42.50.-p,42.50.Ar

How to probe the correlation time of the electrical current through a quantum conductor? This correlation time arises from the most basic property of electrical charge carriers, namely their fermionic nature. The current through a biased two terminal quantum conductor can be represented as the emission of wave packets, occupied by one electron, regularly spaced in time[1]. The temporal width and spacing of these wave packets is the correlation time τ_{source} of the electrical current. The electrons are scattered back or forth within the conductor. The quantum uncertainty of the scattering (partition noise) yields to current fluctuations called shot noise [1, 2, 3, 4]. Measuring the shot noise thus amounts to determine whether electrons have been transmitted or not. This cannot be done on time scales shorter than the width of the incoming electron wave packets τ_{source} . Therefore, the shot noise power vanishes for frequencies corresponding to time scales shorter than τ_{source} . In this letter, we report on measurements of this crossover in a single mode conductor, yielding to the first direct comparison to the high frequency shot noise scattering theory without adjustable parameters.

We briefly summarize the quantitative treatment which put the qualitative approach of the introduction on firmer ground (see ref [2] for a more detailed discussion). If one considers a two terminal conductor, the source coherence time is given by $\tau_{\text{source}} = h/eV_{ds}$, where V_{ds} stands for the potential difference between the two contacts. The noiseless incoming current is thus $I_0 = 2eV_{ds}/h$ for each spin-degenerate electronic mode. At zero temperature, the zero frequency shot noise spectral density is then $S_I(0) = 2eI_0 \sum_i D_i(1 - D_i)$. The last factor comes from the variance of the binomial statistics for electrons crossing the conductor in mode (i) with transmission probability D_i [2, 3, 4]. The shot noise power is reduced if one probes the system on time scales

comparable to electron correlation time h/eV [5]. More specifically, in order to detect shot noise at frequency ν , a photon energy $h\nu$ has to be transmitted from the sample to the detection circuit. The energy range of electrons able to participate to current fluctuations is then $eV_{ds} - h\nu$ for $V_{ds} > h\nu/e$. Thus, the finite frequency shot noise is reduced to $S_I(\nu) = S_I(0)(eV_{ds} - h\nu)/eV_{ds}$, and is completely suppressed for $V_{ds} < h\nu/e$. This suppression is very similar to that of finite frequency equilibrium thermal noise when $k_B T < h\nu$, when electrons have not enough thermal energy to emit photons.

Accurate measurements of low frequency shot noise have definitely established the validity of the scattering picture of quantum transport [6, 7]. However, much less is known about high frequency quantum shot noise. A first motivation to investigate this regime was that a direct experimental test of the theory was missing. A second motivation is the recent prediction that in the frequency range $\simeq eV_{ds}/2h$ to eV_{ds}/h , current fluctuations could lead to non-classical photon emission [8, 9, 10] in the external measuring circuit, when only one or few electronic modes are transmitted, for instance in a Quantum Point Contact. Another interesting aspect is the modification of the quantum transport laws at high frequencies which may lead to departure from the above shot noise picture [11] in experimental configurations where inclusion of current conservation effects may be important [12, 13].

The first finite frequency shot noise measurements on normal conductors have been done using diffusive conductors [14]. While measurements were consistent with theory, the diffusive conductor did not allow to vary transmission nor to probe the few transmission mode regime. More recently, a Quantum Dot has been used as on-chip detector to probe the shot noise of a QPC in the 10 to 150 GHz frequency range[15]. Here most features

expected for QPC shot noise were observed qualitatively, validating the photo-detection method. However the lack of knowledge of coupling parameters prevent quantitative shot noise measurements. The QPC voltages used was very large, in the range 0.05 to $0.5E_{Fermi}$, and the quantum limit cut-off frequency of shot noise was larger than expected ($V_{ds} \simeq 5 \times h\nu/e$).

In this letter, we present the first accurate test of the scattering theory of finite frequency quantum shot noise for normal coherent conductors using a Quantum Point Contact in the 4-8GHz frequency range. The direct measurement of the total excess noise, the ability to tune and control electronic mode transmissions, the small energy scale used ($eV_{ds} \ll 0.02E_{Fermi}$) ensuring energy independent transmissions and allowing to probe the photon limited regime ($k_B T < h\nu$, $eV_{ds} < \text{or} > h\nu$), give unprecedented clean conditions for a direct comparison between experiment and theory with no adjustable parameters.

The experimental set-up is represented in figure 1. The two-terminal conductor is a QPC realized in a 2DEG in GaAs/GaAlAs heterojunction inserted between two transmission lines and placed in a dilution refrigerator. The sample characteristics are a 35 nm deep 2DEG with $36.7 \text{ m}^2 \text{ V}^{-1} \text{ s}^{-1}$ mobility and $4.4 \cdot 10^{15} \text{ m}^{-2}$ electron density. In order to increase the sensitivity, both contacts are separately connected to 50Ω coaxial transmission lines via two quarter wave length impedance adapters, raising the effective input impedance of the detection lines to 200Ω over a one octave bandwidth centered on 6GHz. The transmitted signals are then amplified by two cryogenic Low Noise Amplifiers, with $T_{\text{noise}} \simeq 5K$. Two circulators, thermally anchored to the mixing chamber temperature (65 mK) protect the sample from the current noise of the cryogenic amplifiers (thus, the electromagnetic environment seen by the QPC is 200Ω at base temperature). After further amplification and eventually narrow bandpass filtering at room temperature, current fluctuations are detected using two calibrated quadratic detectors whose output voltage is proportional to noise power. Up to a calculable gain factor, the detected noise power contains the weak sample noise on top of a large additional noise generated by the first cryogenic amplifiers. In order to remove this background, we measure the excess shot noise, i.e. $\Delta S_I(\nu, T, V_{ds}) = S_I(\nu, T, V_{ds}) - S_I(\nu, T, 0)$. Practically, this is done by applying a 93 Hz $0-V_{ds}$ square-wave bias voltage on the sample through the DC input of a bias T, and detecting the first harmonic of the square-wave noise power response of the detectors using lock-in techniques. In terms of noise temperature, referred to the 50 Ohms input impedance, a shot noise variation gives rise to a noise temperature variation of:

$$\Delta T_n^{50\Omega}(\nu, T, V) = \frac{Z_{\text{eff}} Z_{\text{sample}}^2}{(2Z_{\text{eff}} + Z_{\text{sample}})^2} \Delta S_I(\nu, T, V) \quad (1)$$

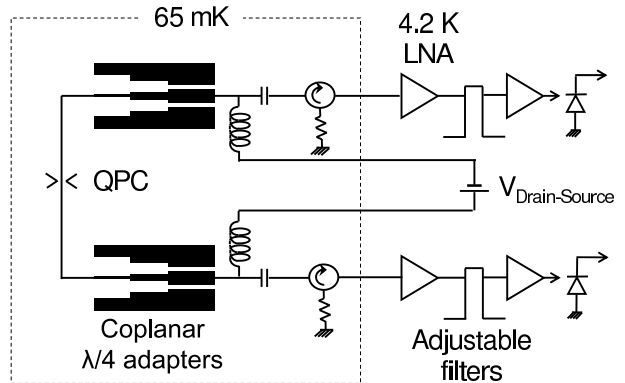

FIG. 1: Schematic diagram of the measurement set-up. Both sides of the QPC are connected to two 50Ω coaxial transmission lines via two quarter wave length impedance adapters, raising the effective input impedance of the detection line to 200Ω . Two circulators, thermalized at 65 mK, protect the sample from the noise radiated by amplifiers. The transmitted signal is amplified by two cryogenic Low Noise Amplifiers, with $T_{\text{noise}} \simeq 5K$. The signal is further amplified and filtered at room temperature and detected by a quadratic detectors which output voltage is proportional to the total noise temperature.

Equation 1 demonstrates the advantage of impedance matching: in the high source impedance limit $Z_{\text{sample}} \gg Z_{\text{eff}}$, the increase in noise temperature due to shot noise is proportional to Z_{eff} . With the $200 \Omega / 50 \Omega$ impedance transformer, our set up is thus four times more efficient than when directly connecting the sample to standard 50Ω transmission lines. Finally, the Quantum Point Contact differential conductance is simultaneously measured through the DC input of the bias T with a low frequency lock-in technique.

We first characterize the Quantum Point Contact. The inset of figure 4 shows the differential conductance versus gate voltage when the first two modes are transmitted. As the experiment is performed at zero magnetic field, the conductance exhibits plateaus, quantized in units of $G_0 = 2e^2/h$. We used a short Quantum Point Contact (the constriction determined by the split gates are 80 nm long) in order to reduce the dependance of the sample conductance with bias voltage ($\delta G/G \leq 6\%$ for $V_{ds} \leq 80 \mu\text{V}$ for $G \simeq 0.5 G_0$). As a consequence, the plateaus are not very pronounced. The measured conductance (open circles) is well described by the saddle point model (solid line) introduced in Ref.[16]. From the fitting parameters, one can establish a direct correspondence between the total conductance of the sample and the transmissions of the different modes of the QPC.

We then set the gate voltage to obtain only one mode, half transmitted ($G \simeq 0.5 G_0$). Figure 2 shows the shot noise measured for two different frequencies 4.77 GHz and 7.63 GHz and bandwidth 90 MHz and 180 MHz respectively. As we have two independent detection chains, the measurements have been done *simultaneously*. We

note a striking suppression of shot noise variation at low bias voltage, and that the onset of noise increases with the measurement frequency. This feature is in agreement with the expected suppression of shot noise at high frequency.

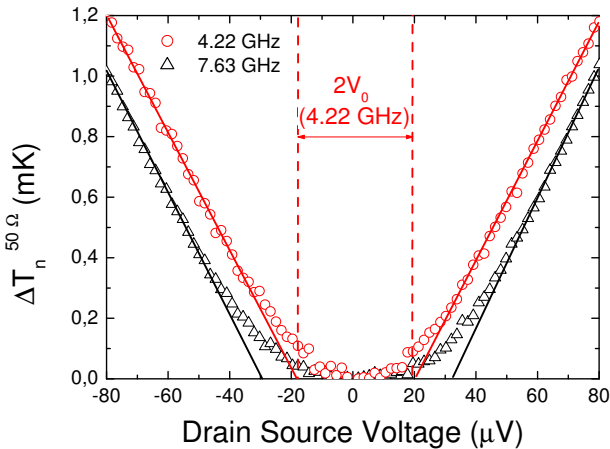

FIG. 2: Excess noise temperature, referred to the 50Ω input impedance, as a function of bias voltage, measured at 4.22 GHz (open circles) and 7.63 GHz (open triangles). The solid lines represent the linear fits to the data in the $[-80 \mu\text{V}, -50 \mu\text{V}]$ range for V_{ds} , and in $[50 \mu\text{V}, 80 \mu\text{V}]$ range, from which the intercept V_0 is deduced.

To guarantee that the increase in noise temperature is due to shot noise and not to heating, we repeat the same experiment at fixed frequency (here we used a 5.4–5.9 GHz filter) for different conductances. We plot the slope $d\Delta T_n/dV$ measured between $50 \mu\text{V}$ and $80 \mu\text{V}$. The energy range is chosen so that eV is greater than $h\nu$ by at least $5k_B T_{\text{fridge}}$ over the entire frequency range. As one can see on figure 4, the data agree qualitatively with the expected D(1-D) dependence of pure shot noise.

We now give a quantitative comparison between our measurements and the high frequency scattering model for quantum shot noise. The expected excess power spectrum is given by:

$$\Delta S_I(\nu, T, V) = 2G_0 \sum_i D_i (1 - D_i) \left(\frac{h\nu - eV}{e^{(h\nu - eV)/k_B T} - 1} + \frac{h\nu + eV}{e^{(h\nu + eV)/k_B T} - 1} - \frac{2h\nu}{e^{h\nu/k_B T} - 1} \right), \quad (2)$$

where D_i stands for the transmission of the i^{th} spin degenerate mode. This gives a cusp in the noise power at zero temperature: $\Delta S_I(\omega, T, V) = 2G_0 \sum_i D_i (1 - D_i) (eV - h\nu)$ if $eV > h\nu$ and 0 otherwise. At finite temperature, the cusp is thermally rounded. At high bias ($eV \gg h\nu, k_B T$), equation 2 gives a shot noise variation :

$$\Delta S_I(\nu, T, V) = 2G_0 \sum_i D_i (1 - D_i) (eV - eV_0), \quad (3)$$

with

$$eV_0 = h\nu \coth \left(\frac{h\nu}{2k_B T} \right). \quad (4)$$

In the low frequency limit V_0 characterizes the transition between Johnson-Nyquist noise and shot noise ($eV_0 = 2k_B T$), whereas in the low temperature limit, it marks the onset of photon suppressed shot noise ($eV_0 = h\nu$).

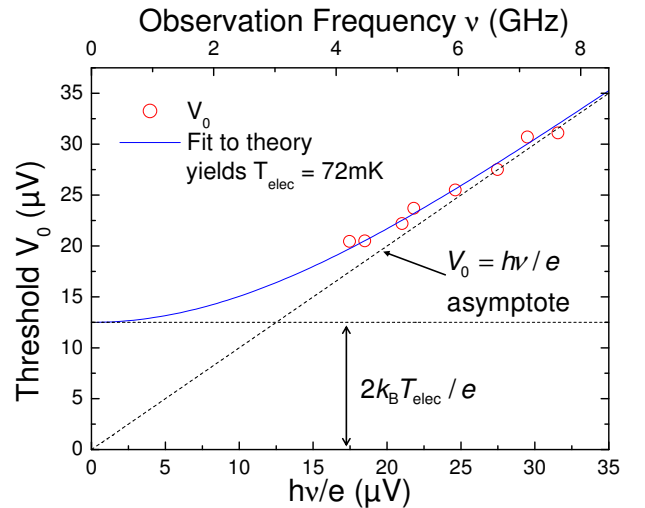

FIG. 3: Intercept of the excess noise asymptote with the zero excess noise axis, plotted as a function of the observation frequency. The dashed line correspond to the low frequency ($eV_0 = 2k_B T$) and high frequency ($eV_0 = h\nu$) limits, and the solid line is a fit to theory, with the electronic temperature as only fitting parameter.

As shown on figure 2, V_0 is determined by the intersection of the high bias linear regression of the measured excess noise and the zero excess noise axis. Figure 3 shows the variation of V_0 , as a function of the observation frequency, measured at fixed conductance $G \simeq 0.5G_0$. Equation 4 gives a very good fit to the experimental data. The only fitting parameter is the electronic temperature $T_{\text{elec}} = 72 \text{ mK}$, in good agreement with the fridge temperature (65 mK).

To get a quantitative comparison between theory and the measured variation of shot noise with transmission, one must evaluate the increase in electron temperature due to finite bias-voltage. The sample dimensions being much larger than the electron-electron energy relaxation length, but much smaller than electron-phonon energy relaxation length, we are in the 'hot electrons' regime. If one assumes that electrons within the ohmic contacts remain at the lattice temperature, the electronic temperature is given by the Wiedemann-Franz law [7]:

$$T_e^2 = T_0^2 + \frac{24}{\pi^2} \frac{G}{G_m} \left(1 + \frac{2G}{G_m} \right) \left(\frac{eV}{2k_B} \right)^2, \quad (5)$$

where G_m stands for the *total* conductance of the 2D leads, estimated from the conductance measurements to $12 \text{ mS} \pm 20\%$. The increased noise temperature is then due to both shot noise and to the increased Johnson-Nyquist noise. For a lattice temperature of 65 mK and a $80 \mu\text{V}$ bias voltage one gets an effective temperature 85 mK at $G = G_0/2$. This accounts for the small discrepancy between the fridge temperature and the electron temperature deduced from the variation of V_0 with frequency. For $G = 2G_0$, one gets an electron temperature of 115 mK at $80 \mu\text{V}$ excitation voltage. The photon energy is thus still significantly higher than $k_B T$, strongly reducing the influence of thermal effects.

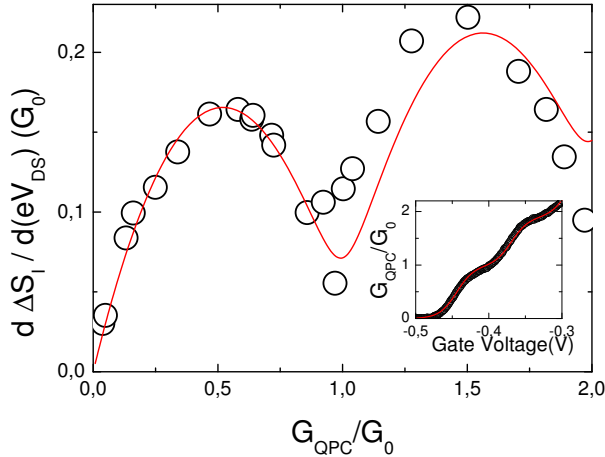

FIG. 4: Open circles: Derivative of the excess current noise deduced from the measured increase of the noise temperature. Full line: theoretical prediction, based on the transmissions of the different modes deduced from the QPC conductance. The only fitting parameter is the attenuation of the Microwave Signal. Inset: Open circles: conductance of the sample as a function of the applied gate voltage. Solid Line: fit with the 'Saddle Point Model' from ref. [16].

We extract the slope $d\Delta S_I/d(eV)$ from a linear regression to the experimental data between $50 \mu\text{V}$ and $80 \mu\text{V}$ drain source voltage. Figure 4 displays $d\Delta S_I/d(eV)$ as a function of the sample conductance, both normalized to G_0 . The solid line gives the total expected excess current noise, estimated from equations 2 and 5, using the attenuation of the signal as a free parameter. The contribution due to electron heating is evaluated by calculating the difference of Johnson-Nyquist noise (at zero bias voltage) at the maximum temperature (at $80 \mu\text{V}$) and the minimum temperature (at $50 \mu\text{V}$) of the drain source excursion. The agreement is quite satisfactory, given the accuracy of the saddle-point model description of the quantum point contact transmission, which assumes constant width and spacing of the conductance plateaus. We find a 5 dB attenuation, in good agreement with the expected 6 dB deduced from calibration of the various elements of the detection chain.

In conclusion, we performed the first direct measurement of the finite frequency shot noise of the simplest mesoscopic system, a quantum point contact. The data are found in quantitative agreement with theoretical predictions. The technique we developed should be very useful to investigate the statistical properties of photons produced by a phase coherent single mode conductor, or the finite frequency shot noise of strongly correlated systems.

It is a pleasure to thank Patrice Jacques and Claudine Chaleil for valuable help in the construction of the experiments, Preden Roulleau for technical help, and Xavier Waintal for useful discussions. The Laboratoire Pierre Aigrain (LPA) is the CNRS-ENS UMR8551 associated with universities Paris 6 and Paris 7.

* Electronic address: fabien.portier@cea.fr

† Also at Laboratoire Pierre Aigrain, Ecole Normale Supérieure, Paris.

- [1] T. Martin and R. Landauer, Phys. Rev. B **45**, 1742 (1992).
- [2] Y. M. Blanter and M. Büttiker, Phys. Rep. **336**, 1 (2000)
- [3] G. B. Lesovik, Pis'ma Zh. Eksp. Teor. Fiz. **49** (1989) 513; JETP Lett. **49** (1989) 592.
- [4] V. A. Khlus, Zh. Eksp. Teor. Fiz. **93** (1987) 2179 [Sov. Phys. JETP **66** (1987) 1243].
- [5] G.B. Lesovik, R. Loosen, JETP Lett. **65**, 295 (1997); R. Aguado and L. P. Kouwenhoven, Phys. Rev. Lett. **84**, 1986 (2000); U. Gavish, Y. Levinson, Y. Imry, Phys. Rev. B **62**, R10637 (2000). For a first high frequency shot noise derivation, not making the distinction between emitted noise $S_I(\nu)$ and stimulated noise $S_I(-\nu)$, see Ref.[4].
- [6] M.Reznikov, M. Heiblum, H. Shtrikman, and D. Mahalu, Phys. Rev. Lett. **75**, 3340 (1995).
- [7] A. Kumar *et al.*, Phys. Rev. Lett. **76**, 2778 (1996).
- [8] C. W. J Beenakker and H. Schomerus, Phys. Rev. Lett. **86**, 700 (2001).
- [9] J. Gabelli, L.-H. Reydellet, G. Fève, J.-M. Berroir, B. Placais, P. Roche, and D. C. Glattli, Phys. Rev. Lett. **93**, 056801 (2004).
- [10] C. W. J. Beenakker and H. Schomerus Phys. Rev. Lett. **93**, 096801 (2004).
- [11] M. H. Pedersen, S. A. van Langen, and M. Buttiker, Phys. Rev. B **57** (1998) 1838.
- [12] M. Büttiker, H. Thomas, and A. Prêtre, Phys. Lett. **A180**, 364 (1993); M. Büttiker, A. Prêtre, H. Thomas, Phys. Rev. Lett. **70**, 4114 (1993).
- [13] J. Gabelli, G. Fève, J.-M. Berroir, B. Placais, A. Cavanna, B. Etienne, Y. Jin, and D.C. Glattli, Science **313**, 499 (2006).
- [14] R. J. Schoelkopf, P. J. Burke, A. A. Kozhevnikov, M. J. Rooks, and D. E. Prober, Phys. Rev. Lett. **78**, 3370 (1997).
- [15] E. Onac, F. Balestro, L. H. W. van Beveren, U. Hartmann, Y. V. Nazarov, and L. P. Kouwenhoven Phys. Rev. Lett. **96**, 176601 (2006).
- [16] M. Büttiker Phys. Rev. B **41**, 7906-7909 (1990).