



HAL
open science

Multiaxial fatigue criteria based on a multiscale approach

K. Dang Van

► **To cite this version:**

K. Dang Van. Multiaxial fatigue criteria based on a multiscale approach. J. Lemaître. Handbook of Materials Behavior Models, Academic Press, pp.457-463, 2001, 978-0-12-443341-0. 10.1016/B978-012443341-0/50052-1 . hal-00112290

HAL Id: hal-00112290

<https://hal.science/hal-00112290v1>

Submitted on 26 Jul 2019

HAL is a multi-disciplinary open access archive for the deposit and dissemination of scientific research documents, whether they are published or not. The documents may come from teaching and research institutions in France or abroad, or from public or private research centers.

L'archive ouverte pluridisciplinaire **HAL**, est destinée au dépôt et à la diffusion de documents scientifiques de niveau recherche, publiés ou non, émanant des établissements d'enseignement et de recherche français ou étrangers, des laboratoires publics ou privés.

Multiaxial Fatigue Criteria Based on a Multiscale Approach

K. DANG VAN

Laboratoire de Mécanique des Solids, Ecole Polytechnique, 91128 Palaiseau, France

6.9.1 VALIDITY

Prediction of high-cycle fatigue resistance is of great importance for structural design. In spite of this clear industrial need, until now modeling of metal behavior in a high-cycle fatigue regime was often based on empirical approaches: the Wöhler curve and the Goodman–Haigh or Gerber diagrams are still the very popular tools for engineers. However, these concepts are not appropriate when studying the multiaxial stress cycles that are frequently encountered on modern mechanical components. These multiaxial stresses arise from factors such as external loadings, the geometry of the structure, which can induce multiaxiality even if the loading is uniaxial, and finally residual stresses.

6.9.2 BACKGROUND

In order to derive a multiaxial endurance fatigue criterion, an original method of computing based on a multiscale approach was proposed by Dang Van.

This method is quite different from existing fatigue approaches. It arises from the observation that generally the first fatigue damage processes begin in grains which have undergone plastic deformation, with the appearance of slip bands in some grains which broaden progressively with the applied cycles; this stage is then followed by localized damage corresponding to formation of intragranular microcracks; these microcracks can be arrested by grain boundaries, but they may also propagate. After a certain number of cycles, a main crack initiates, grows in size, and shields the other defects and consequently leads to the final rupture of mechanical structure. In a high-cycle fatigue regime, even if it is necessary to have plastic deformation at the micro- or the mesoscale (corresponding to the grain size), most of the time no visible irreversible deformation at the macroscopic level can be detected. It is thus characterized by a large heterogeneity of plastic deformation from grain to grain: only certain misoriented crystals undergo plastic slips, and in this way a very heterogeneous distribution of microcracks can be observed. In this fatigue regime, the initiation of the first visible cracks takes a large part of the fatigue life of the structure. It demonstrates the importance of studying conditions governing the crack initiation process.

In most of the existing fatigue models, these conditions are described with the help of *macroscopic parameters* which are evaluated according to different assumptions of homogeneity and isotropy. For example, engineers evaluate the stress Σ not at a point of a structure but over a finite volume V that defines the macroscopic scale which is used (see Fig. 6.9.1). Typically V is of the order of the dimension of the strain gauges. However, because the phenomena which cause fatigue initiation are microscopic, the local parameters (for example, local stress σ) differ from the macroscopic ones. Thus the use of classical macroscopic engineering parameters does not seem pertinent, since,

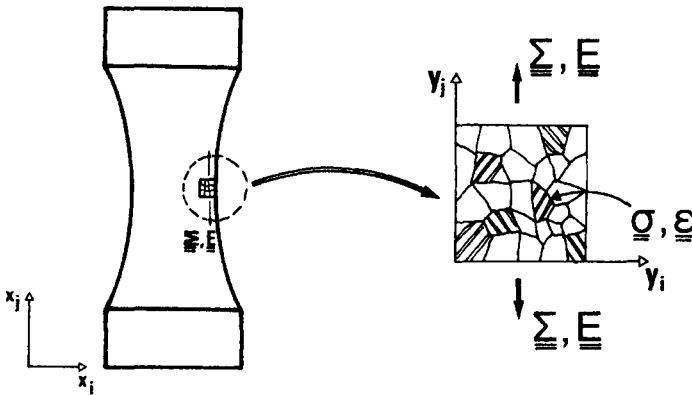

FIGURE 6.9.1 Different scales of material description: the macro- and mesoscopic scales.

at that local scale, the material cannot be considered anymore as homogeneous. In particular, the local redistributions induced by the inhomogeneous incompatible strains $\boldsymbol{\varepsilon}_p$, and as a consequence local residual stress $\boldsymbol{\rho}$, are not accounted for.

6.9.3 FORMULATION

The originality in Dang Van's proposal is precisely the use of local mesoscopic mechanical parameters $\boldsymbol{\sigma}$ to derive fatigue resistance criteria. These parameters are evaluated from the macroscopic parameters thanks to a hypothesis of elastic shakedown. *More precisely, it is postulated that, near the fatigue limit threshold, the mechanical structure shakes down elastically at all scales of material description. Under this assumption, the precise knowledge of the local constitutive equations, which is not possible to evaluate, is not necessary.* The physical interpretation of this hypothesis is that after a certain number of loading cycles the response is purely elastic (or at least the *plastic dissipation rate becomes negligible*). Then, using shakedown theorems (Melan's theorem and its generalization by different authors; (see, for instance, Reference [1]), it is possible to derive a method for estimating the apparent stabilized stress (tensorial) cycle at the macroscopic and mesoscopic level which intervenes in the proposed fatigue criteria, provided that the material is considered a structure made of grains of different crystallographic orientations.

Theoretical developments of this theory are presented in Reference [2]. For practical applications, it is only necessary to remember how to derive local parameters from macroscopic stress cycles near the fatigue limit, which is presented in following text.

The general relation between macroscopic and local stress tensor is

$$\boldsymbol{\sigma}(m, t) = \mathbf{A} \cdot \boldsymbol{\Sigma}(M, t) + \boldsymbol{\rho}(m, t)$$

This relation is well known in the theory of polycrystalline aggregates. In this equation \mathbf{A} is an elastic localization tensor which depends on the microstructure; $\boldsymbol{\Sigma}(M, t)$ is the macroscopic stress tensor at time t in the representative volume element $V(M)$ surrounding M , and $\boldsymbol{\sigma}(m, t)$ and $\boldsymbol{\rho}(m, t)$ are, respectively, the local stress tensor and the residual stress tensor at any point m of $V(M)$. For the sake of simplicity, let us assume that $\mathbf{A} = \text{identity}$ (elastic homogeneity); then $\boldsymbol{\rho}$ characterizes the local stress fluctuation in $V(M)$.

If elastic shakedown happens, then $\boldsymbol{\rho}$ must become independent of time after a certain number of cycles, so that the local plastic yield criterion $f(m)$ is no longer violated. Assuming that an approximate elastic shakedown occurs if the loading cycles are near the fatigue limit, then there must exist a local fixed

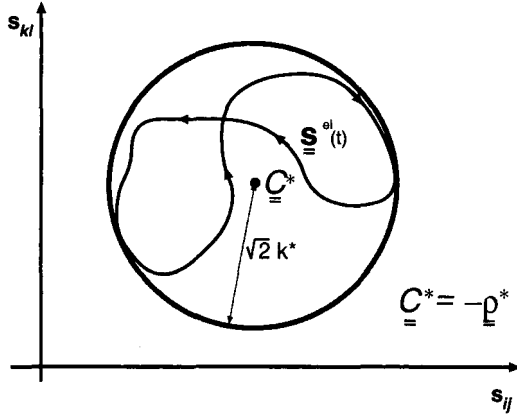

FIGURE 6.9.2 Determination of the local residual stress ρ^* at the shakedown state.

(independent of time) residual stress tensor $\rho^*(m)$ and a fixed set of local hardening parameters $\alpha(m)$ such that:

$$\sigma(m, t) = \Sigma(M, t) + \rho^*(m)$$

$$f(\sigma(m, t), \alpha(m)) \equiv f(\Sigma(M, t) + \rho^*(m), \alpha(m)) \leq 0$$

If the Mises criterion is chosen, then $\sigma(m, t)$ belongs to the hypersphere in five dimensional space, representing the limiting value of the Mises norm for which elastic shakedown is possible. Mandel *et al.* [1] showed that $\rho^*(m)$ can be approximately taken to be the center of the smallest hypersphere surrounding the loading path in the deviatoric macroscopic stress space represented in Figure 6.9.2. In this figure, S (resp. s) represents the deviatoric stress corresponding to Σ (resp. σ). Because of the shakedown hypothesis at all scales of material description, S at stabilization is also elastic. Finally, by that construction, the local stress state is known at any time t of the apparent stabilized state.

One must still choose a fatigue criterion. Since the local stress is approximately known at any time t , it is natural to try to take account of the characteristic of the loading path (as in plasticity). Thus a reasonable fatigue criterion could be stated as follows.

Crack initiation will occur in a critically oriented locus (usually corresponding to a grain) within $V(M)$ that has undergone plastic deformation, if, for at least one time instant t of the stabilized cycle, one has

$$F[(\sigma(m, t))] \geq 0 \quad \text{for } m \in V(M)$$

In such a criterion, the current stress is considered, in contrary to most (or all) existing fatigue criteria. Damage arises over a precise portion of the loading path (or equivalently, over a precise time interval of the loading period). Since cracks usually occur in transgranular slip bands, the local shear acting on these planes is an important parameter. Moreover, the normal stress acting on these planes accelerates damage formation. However, this quantity is rather difficult to compute generally because it depends of the considered plane. For this reason, hydrostatic stress is preferred because it is much easier to use, being an invariant scalar. Furthermore, it can be interpreted as the mean value of the normal stresses acting on all the planes that pass through the considered point of the structure. Based on these remarks, $F(\boldsymbol{\sigma})$ is chosen to be a function of the local shear τ and the local hydrostatic stress p .

6.9.4 IDENTIFICATION OF THE PARAMETERS

The simplest criterion that can be conceived is a linear relation between these quantities,

$$F(\boldsymbol{\sigma}) \equiv \tau + ap - b$$

where a and b are material parameters that can be determined by two simple types of fatigue experiments: uniaxial tests of tension-compression and torsion on classical fatigue test machines. If f is the fatigue limit strength in alternate tension-compression, and t is the fatigue limit in alternate twisting, then

$$a = \frac{t - f/2}{f/3}, \quad b = t$$

The safety domain (no fatigue crack initiation) is delimited by the two straight lines represented in Figure 6.9.3. The ordinate is the algebraic shear stress acting in an oriented direction, and the abscissa is the hydrostatic stress p . On the same figure the loading paths for fatigue limit in tension compression and in twisting are represented. Two more loading paths are shown. Path Γ_1 is nondamaging because it lies entirely within the straight lines that delimit the safe domain, whereas a small portion of path Γ_2 induces damage.

6.9.5 HOW TO USE THE MODEL

To check automatically the fatigue resistance of a structure is a rather difficult task, because at each point one has to consider the plane on which the loading path $(\tau[t], p[t])$ is a “maximum” relative to the criterion. This computation can

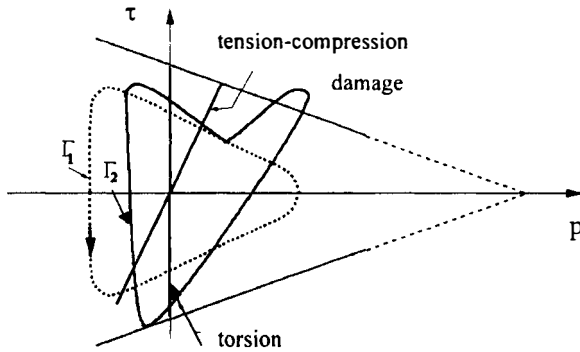

FIGURE 6.9.3 Fatigue limit domain and loading paths.

be simplified as follows. The maximum shear stress according to Tresca's measure is calculated over the cycle period:

$$\tau(t) = \text{Tresca}[\sigma(t)]$$

It is useful to notice that

$$\text{Tresca}[\sigma(t)] = \text{Tresca}[s(t)] = \text{Max}_{ij} |\sigma_i(t) - \sigma_j(t)|/2$$

The stresses $\sigma_i(t)$ and $\sigma_j(t)$ are principal local stresses at time t . The quantity d that quantifies the danger of fatigue failure defined by

$$d = \text{Max}_t \frac{\tau(t)}{b - ap(t)}$$

is calculated over the loading period. The maximum is to be taken over the cycle. If $d > 1$, the fatigue failure will occur.

Working this way, all couples (τ, p) are situated in the positive part of τ . All facets which could be involved by the crack initiation are automatically reviewed. Couples (τ, p) verifying the condition $d > 1$ are associated with specific facets. Therefore, the criterion also provides the direction of crack initiation.

Another possibility is to use the octahedral shear $J_2[\sigma(t)]$ instead of $\tau(t)$. However, this method does not give the critical facets.

Another interesting proposal derived from the multiscale approach was given by I.V.Papadopoulos: the fatigue limit for a given periodic loading $\lambda Q(t)$ corresponds to the limit of the intensity λ such that elastic shakedown is possible. Beyond this limit, plastic shakedown or ratchet phenomena will induce damage and fracture because of subsequent softening. The limit size k^*

of the hypersphere surrounding the loading path (as explained previously) is one possible and natural way to characterize this state. If k^* is greater than some limit value which depends on the local maximum hydrostatic stress in the cycle, fatigue will occur. This corresponding fatigue criterion is

$$k^* + \alpha p_{\max} - \beta > 0$$

As previously, the parameters α and β can be identified by two different tests. By this method it is no longer necessary to describe the whole loading path once k^* is determined. In many cases, the predictions are very similar to the current state methodology as presented previously.

REFERENCES

1. Mandel, J., Halphen, B., and Zarka, J. (1977). Adaptation d'une structure elastoplastique à ecrouissage cinématique. *Mech. Res. Comm.* 4: 309–314.
2. Dang Van, K. (1999). Introduction to fatigue analysis in mechanical design by the multiscale approach, in *C.I.S.M. Courses and Lectures N° 392 on High Cycle Metal Fatigue, from Theory to Applications*, Dang Van, K., and Papadopoulos, I.V., eds., New York: Springer Wien.