



HAL
open science

Critical Exponents of Planar Gradient Percolation

Pierre Nolin

► **To cite this version:**

| Pierre Nolin. Critical Exponents of Planar Gradient Percolation. 2006. hal-00109036v1

HAL Id: hal-00109036

<https://hal.science/hal-00109036v1>

Preprint submitted on 23 Oct 2006 (v1), last revised 22 Dec 2006 (v2)

HAL is a multi-disciplinary open access archive for the deposit and dissemination of scientific research documents, whether they are published or not. The documents may come from teaching and research institutions in France or abroad, or from public or private research centers.

L'archive ouverte pluridisciplinaire **HAL**, est destinée au dépôt et à la diffusion de documents scientifiques de niveau recherche, publiés ou non, émanant des établissements d'enseignement et de recherche français ou étrangers, des laboratoires publics ou privés.

Critical Exponents of Planar Gradient Percolation

Pierre Nolin

École Normale Supérieure and Université Paris-Sud

Abstract

We study gradient percolation for site percolation on the triangular lattice. This is a percolation model where the percolation probability depends linearly on the location of the site. We prove the results predicted by physicists for this model. More precisely, we describe the fluctuations of the interfaces around their (straight) scaling limits, the expected and typical lengths of these interfaces. These results build on the recent results for critical percolation on this lattice by Smirnov, Lawler, Schramm and Werner, and on the hyperscaling ideas developed by Kesten.

1 Introduction

We study some aspects of “gradient percolation”. This is a model of inhomogeneous site percolation where the probability for each site to be occupied varies along some fixed direction, for instance the y-axis in the plane. It has been introduced by physicists (see [21, 22]) who argued that this is one of the cases in which one can actually “see” some aspects of critical percolation in real life.

Since we will be concentrating on the triangular planar lattice anyway, let us briefly describe the model in this particular case, even if it makes sense for other lattices and dimensions.

Recall that if one colors each cell of a honeycomb lattice independently in black or white with respective probability p and $1 - p$, then when $p > 1/2$ there is an infinite connected component of black cells, and when $p < 1/2$ there is an infinite connected component of white cells. The number $1/2$ is called the critical probability of this homogeneous percolation model : the particular value $p = 1/2$ gives rise to critical percolation. This model has recently received a lot of attention, which has led among others to the computation of the “critical exponents” (see [27]).

Suppose now that a large integer N is given. We now consider an inhomogeneous percolation model, where each cell z is colored in black and white independently, but with a probability that depends on z . More precisely, a cell z with y -coordinate equal to $y(z) \in [0, N]$ will be colored in black with probability $p(z) = y/N$ (when $y < 0$, we take $p(z) = 0$ and when $y > N$, we take $p(z) = 1$). It is then easy to see that there almost surely is a (unique) infinite black connected component (that contains the half space $\{y > 1\}$) and a unique white connected component (containing the half-space $\{y < 0\}$). Furthermore, the uppermost boundary of this white cluster and the lower boundary of the black cluster coincide. This separating curve is called the “percolation front”.

Intuitively, it is quite clear what happens when N is large. The percolation front will tend to be localized near the line $\{y/N = 1/2\}$. Furthermore, since at this level, the percolation is close to critical, the fine structure of the percolation front will be described in terms of critical percolation and its critical exponents.

Let us now briefly describe the main results of the present paper. Suppose that we restrict ourselves to a strip of height N and of length ℓ_N . Then, as $N \rightarrow \infty$ (provided ℓ_N goes to infinity too – not too fast but not too slowly – for instance $\ell_N = N$ is OK for what follows), one can with high probability still define “the” percolation front separating the two “giant components”. We call \mathcal{R}_N the front, and T_N its length (*i.e.* number of steps). We shall see that for each positive δ , when $N \rightarrow \infty$, and with high probability:

- The front will remain in the strip of width $N^{4/7+\delta}$ near the line $\{y = N/2\}$.
- The front will not remain in the strip of width $N^{4/7-\delta}$ near the line $\{y = N/2\}$.
- The expected length $t_N = \mathbb{E}[T_N]$ of the front satisfies $N^{3/7-\delta}\ell_N \leq t_N \leq N^{3/7+\delta}\ell_N$.
- T_N is close to its expected value, *i.e.* T_N/t_N is close to 1.

The proofs of these results build on the following mathematical results and ideas : Kesten’s hyperscaling relations [16], Smirnov’s conformal invariance result [26], and the computation of the critical exponents for SLE_6 by Lawler, Schramm and Werner [18]. More precisely, we shall use directly results of the latter two papers, and develop further some ideas introduced in the first one.

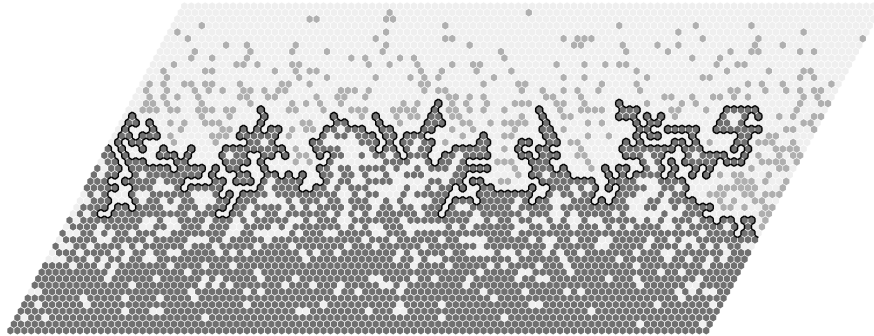

Figure 1: A simulation for $N = 50$ and $\ell_N = 100$

These results had been conjectured by Sapoval et al. in [21, 22] and also raised in the percolation survey paper by Beffara and Sidoravicius in the Encyclopedia for mathematical physics [2].

In fact, it is rather easy to simulate gradient percolation. It has turned out to be an efficient practical tool to obtain numerical estimates for the critical probability of percolation on various lattices (by using the mean height of the front in order to approximate p_c , see e.g. [23, 24]), for instance square lattice, and it has also been one of the first ways to get numerical evidence for values of the critical exponents of critical percolation (that then supported the conjectures based on Coulomb gas and conformal field theory).

Let us stress the fact that the anisotropy of this model yields that despite the fact that the front converges to a straight line in the fine mesh limit (*i.e.* a curve of dimension one), its length for a lattice approximation of mesh-size δ (in a rhombus) behaves roughly like $\delta^{-3/7}$ (*i.e.* it has $\delta^{-10/7}$ steps). Here, the critical exponents do not correspond to a fractal dimension for the limiting object.

2 Preliminaries for (standard) percolation

We recall in this section some known facts concerning percolation (not gradient percolation) that we will use later on.

2.1 Setting

The setting in this paper will be site percolation in two dimensions on the triangular lattice. We will represent it as usual as a random (black or white) coloring of the faces of the hexagonal lattice. It has been proved by Harry Kesten [12] and it is by now a classical fact that for this model, the critical probability is $p_c = 1/2$ and that there is almost surely no infinite cluster when the percolation parameter is taken to be $1/2$. The reason why we focus here on this lattice is that it is (at present) the only one for which conformal invariance in the scaling limit has been proved (Smirnov [26]). Conformal invariance combined with the study of SLE by Lawler, Schramm and Werner [17, 18] entails the exact value of the so-called “critical exponents” that will be instrumental in our considerations. For some other lattices, some inequalities have been proved, that should imply weaker but nevertheless interesting statements, but we will not develop this aspect in the present paper.

The percolation parameter will be denoted by p : each site is *occupied* with probability p , and *vacant* otherwise, independently of each other. The corresponding probability measure on the set of configurations will be referred to as \mathbb{P}_p , and \mathbb{E}_p will be the expectation. We will use oblique coordinates, with the origin in 0 and the basis given by 1 and $e^{i\pi/3}$ (in complex notation). The parallelogram of vertices $a_j + b_k e^{i\pi/3}$ ($j, k = 1, 2$) will thus be denoted by $[a_1, a_2] \times [b_1, b_2]$, and we will often use $S(n) = [-n, n] \times [-n, n]$ and refer to it as the “box of size n ”.

For two positive functions f and g , $f \asymp g$ means that there exist two positive and finite constants C_1 and C_2 such that $C_1 g \leq f \leq C_2 g$ (so that their ratio is bounded away from 0 and $+\infty$), and $f \approx g$ means that $\log f / \log g \rightarrow 1$ (when $p \rightarrow 1/2$ or when $n \rightarrow \infty$, which will be clear from the context).

We now recall some relevant results on critical percolation that we will use in the present paper.

2.2 Arm exponents

We first briefly recall some facts concerning critical exponents for the existence of a certain number of “arms”. These exponents describe the asymptotic behavior of the probability of certain exceptional events :

Let us consider a fixed integer $j \geq 2$. For each positive integers $m \leq n$, define the event $A^j(m, n)$ that there exist j disjoint monochromatic paths from $\partial S(m)$ to $\partial S(n)$ that are not all of the same color (each path is either

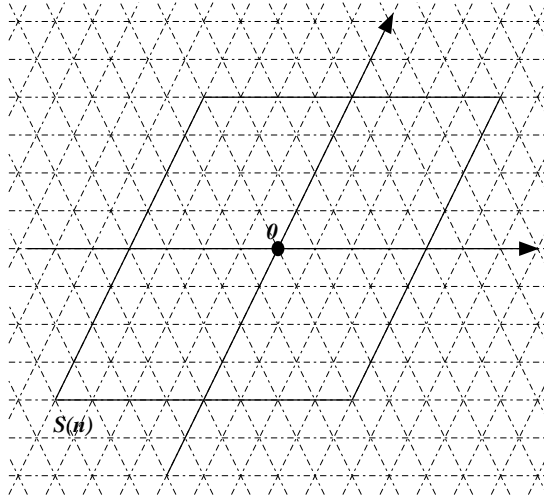

Figure 2: The triangular lattice, its associated basis and $S(n)$

completely open/occupied or completely closed/vacant, and there is at least one vacant path, and one occupied path). As noticed in [1, 27], we could also prescribe the cyclic order of the paths without changing the results that we state below.

Combining the property of conformal invariance in the scaling limit (see [26, 6]) with the study of SLE made by Lawler, Schramm and Werner [18], it has been proved that :

Proposition 1 ([27]). *For all fixed $j \geq 2$, $m \geq j$,*

$$\mathbb{P}_{1/2}(A^j(m, n)) \approx n^{-(j^2-1)/12} \quad (1)$$

when $n \rightarrow \infty$.

In fact, we will use this result only for $j = 2, 3$ and 4. Let us just remark that to derive these three exponents, it might be possible to bypass the use of the rather involved results of Camia and Newman [6] as these are exponents related to outer boundaries of clusters so that “universality”-based ideas might just be enough.

The value of the related “one-arm” exponent is $5/48$ and has been derived in [20], but we shall not need it in the present paper.

2.3 Behavior near criticality

In the seminal paper [16], Harry Kesten showed how the behavior of percolation at its critical point was related to the asymptotic behavior of percolation near its critical point, and derived the so-called hyperscaling relations that link some of the previous arm exponents to other critical exponents describing the behavior of connectivity probabilities near $p = p_c$.

A key idea in his article is to use a certain “characteristic length” $L(p)$ defined in terms of crossing probabilities (sometimes referred to as “sponge-crossing probabilities”). This idea was also used in papers concerning finite-size scaling, e.g. [7, 8, 4, 5]).

Let us introduce some more notation. We will denote by $\mathcal{C}_H([a_1, a_2] \times [b_1, b_2])$ (resp. $\mathcal{C}_V([a_1, a_2] \times [b_1, b_2])$) the event that there exists a horizontal (resp. vertical) occupied crossing of the parallelogram $[a_1, a_2] \times [b_1, b_2]$, and by $\mathcal{C}_H^*, \mathcal{C}_V^*$ the same events with vacant crossings. So, we have for example

$$\mathbb{P}_p(\mathcal{C}_H([a_1, a_2] \times [b_1, b_2])) = 1 - \mathbb{P}_p(\mathcal{C}_V^*([a_1, a_2] \times [b_1, b_2])) \quad (2)$$

Consider now rhombi $[0, n] \times [0, n]$. At $p = 1/2$, $\mathbb{P}_p(\mathcal{C}_H([0, n] \times [0, n])) = 1/2$. When $p < 1/2$ (sub-critical regime), this probability tends to 0 when n goes to infinity, and it tends to 1 when $p > 1/2$ (super-critical regime).

We define a quantity that will roughly measure the scale up to which these crossing probabilities remain bounded away from 0 and 1. For each fixed $\epsilon_0 > 0$, we define

$$L(p, \epsilon_0) = \begin{cases} \min\{n \text{ s.t. } \mathbb{P}_p(\mathcal{C}_H([0, n] \times [0, n])) \leq \epsilon_0\} & \text{when } p < 1/2 \\ \min\{n \text{ s.t. } \mathbb{P}_p(\mathcal{C}_H^*([0, n] \times [0, n])) \leq \epsilon_0\} & \text{when } p > 1/2 \end{cases} \quad (3)$$

If we use the Russo-Seymour-Welsh theory (see e.g. [11, 13]), we see that for each $k \geq 1$, there exists some $\delta_k > 0$ (depending only on ϵ_0) such that

$$\forall N \leq L(p), \quad \mathbb{P}_p(\mathcal{C}_H([0, kN] \times [0, N])) \geq \delta_k \quad (4)$$

These estimates for crossing probabilities are then the basic building blocks on which many further considerations are built. One of the main results of Kesten’s paper [16] is for instance the following one-arm probability estimate :

$$\mathbb{P}_p[0 \rightsquigarrow \partial S(n)] \asymp \mathbb{P}_{1/2}[0 \rightsquigarrow \partial S(n)] \quad (5)$$

for all $n \leq L(p)$ (uniformly in p). In Section 4.1 of the present paper, we will derive the analogous result for “two-arm probabilities”.

This result is basically saying that when n is not larger than $L(p)$, things can be compared to critical percolation. On the other hand, the definition of $L(p)$ shows that when $n > L(p)$, the picture starts to look like super/sub-critical percolation. For instance:

Lemma 2 (exponential decay with respect to $n/L(p)$). *If ϵ_0 has been chosen sufficiently small, there exists a constant $C > 0$ such that for all n , all $p < 1/2$,*

$$\mathbb{P}_p(\mathcal{C}_H([0, n] \times [0, n])) \leq Ce^{-n/L(p)} \quad (6)$$

Variants of this result are implicitly used or mentioned in Kesten's paper [16] or in other papers on finite-size scaling. We now give its proof, as it just takes a couple of lines and clarifies things.

Proof. Observe first that for all integer n ,

$$\mathbb{P}_p(\mathcal{C}_H([0, 2n] \times [0, 4n])) \leq C'[\mathbb{P}_p(\mathcal{C}_H([0, n] \times [0, 2n]))]^2 \quad (7)$$

with $C' = 10^2$ some universal constant. It suffices for that (see figure) to divide the parallelogram $[0, 2n] \times [0, 4n]$ into 4 horizontal sub-parallelograms $[0, 2n] \times [in, (i+1)n]$ ($i = 0 \dots 3$) and 6 vertical ones $[in, (i+1)n] \times [jn, (j+2)n]$ ($i = 0, 1, j = 0 \dots 2$). Indeed, consider a horizontal crossing of the big parallelogram : we can extract from it two pieces, one between its extremity on the left side and its first intersection with the vertical median $x = n$, and in the same way another one starting from the right side. These two sub-paths both cross one of the sub-parallelograms "in the easy way" : as they are disjoint by construction, the claim follows by using the BK inequality ([3, 11]).

We then obtain by iterating :

$$C' \mathbb{P}_p(\mathcal{C}_H([0, 2^k L(p)] \times [0, 2^{k+1} L(p)])) \leq (C' \epsilon_1)^{2^k} \quad (8)$$

as soon as $\epsilon_1 \geq \mathbb{P}_p(\mathcal{C}_H([0, L(p)] \times [0, 2L(p)]))$.

Recall that by definition, $\mathbb{P}_p(\mathcal{C}_H([0, L(p)] \times [0, L(p)])) \leq \epsilon_0$. Consequently, the *RSW* theorem entails that for all fixed $\epsilon_1 > 0$, if we take ϵ_0 sufficiently small, we get automatically (and independently of p) that

$$\mathbb{P}_p(\mathcal{C}_H([0, L(p)] \times [0, 2L(p)])) \leq \epsilon_1 \quad (9)$$

We now choose $\epsilon_1 = 1/(eC')$. For each integer n , we can define $k = k(n)$ such that $2^k \leq n/L(p) < 2^{k+1}$, and then,

$$\begin{aligned} \mathbb{P}_p(\mathcal{C}_H([0, n] \times [0, n])) &\leq \mathbb{P}_p(\mathcal{C}_H([0, 2^k L(p)] \times [0, 2^{k+1} L(p)])) \\ &\leq e^{-2^k} / C' \\ &\leq (e/C') e^{-n/L(p)}. \end{aligned}$$

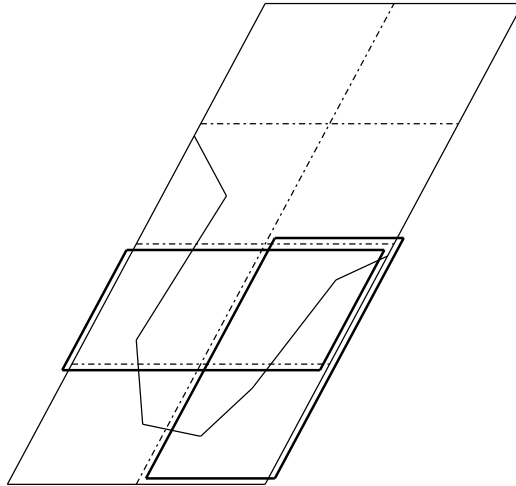

Figure 3: A horizontal crossing of the parallelogram $[0, 2n] \times [0, 4n]$

□

Combining the results of Kesten's paper [16] (in particular remark following Lemma 8, p. 144-145) with the derivation of the arm estimates of Proposition 1 (actually only the 4-arm exponent, counting points which are pivotal for the existence of a crossing) leads to the following :

Proposition 3 ([16, 27]). *When $p \rightarrow 1/2$,*

$$L(p) \approx |p - 1/2|^{-4/3} \tag{10}$$

Remark 4. *It can be shown that for any fixed ϵ_1 and ϵ_2 with $0 < \epsilon_1, \epsilon_2 \leq \epsilon_0$,*

$$L(p, \epsilon_1) \asymp L(p, \epsilon_2). \tag{11}$$

Thus, the particular choice of ϵ_0 is not really important here.

3 Localization of the front

3.1 Framework of gradient percolation

We will now define the model itself and fix some notation. The starting point is still site percolation on the triangular lattice. We first consider a strip \mathcal{S}_N of finite width $2N$ (we assume it to be even for simplicity), centered around the x -axis, such that the y -coordinate varies between $-N$ and N .

This strip may for the moment be unbounded in one or both directions, and we will denote its length by ℓ_N .

In this strip, we assume the parameter to decrease linearly according to y , that is we choose it to be

$$p(y) = 1/2 - y/2N \tag{12}$$

With this choice, all the sites on the bottom edge \mathcal{B}_N will be occupied ($p = 1$), all the sites on the top edge \mathcal{T}_N vacant ($p = 0$). The corresponding probability measure will be denoted by \mathbb{P} .

When we perform such a percolation, two opposite regions appear. At the bottom of \mathcal{S}_N , the parameter is close to 1, we are in a super-critical region and most occupied sites are connected to the bottom edge. On the contrary, we observe on the top a big cluster of vacant sites. The characteristic phenomenon of this model is the existence of a “front”, a continuous line touching in the same time the occupied sites connected (by an occupied path) to the bottom of the strip, and the vacant sites connected to the top (by a vacant path).

Definition 5. *A front will be any interface γ_N (in the sense of a curve formed by sides of the lattice hexagons) between an occupied crossing and a vacant crossing.*

When the length ℓ_N of the strip is finite, there is not necessarily a *unique* front. For instance, there is a positive probability to observe two horizontal crossings, one vacant and one occupied above it. If the strip is infinite, by independence of the different columns there exists almost surely a column on which all the sites, except the highest one, are occupied. In that case, the front is unique and the result of an exploration path (starting from the top of this random column).

However, for practical purposes, it will be more natural to consider finite length strips. The argument above shows that on an infinite strip, exceptional events occur (the front touches the top and the bottom of the strip), and we may expect them not to happen when the length ℓ_N is not too large compared to N .

We now use the strip $\mathcal{S}_N = [0, \ell_N] \times [-N, N]$. We will often consider sub-strips of this big strip. For sake of simplicity, the strip $[0, \ell_N] \times [-N^\alpha, N^\alpha]$ will be written $[\pm N^\alpha]$.

3.2 Localization

We study now the convergence of the front when it is unique. Temporarily, we will consider, instead of “the” front, the highest horizontal crossing, and

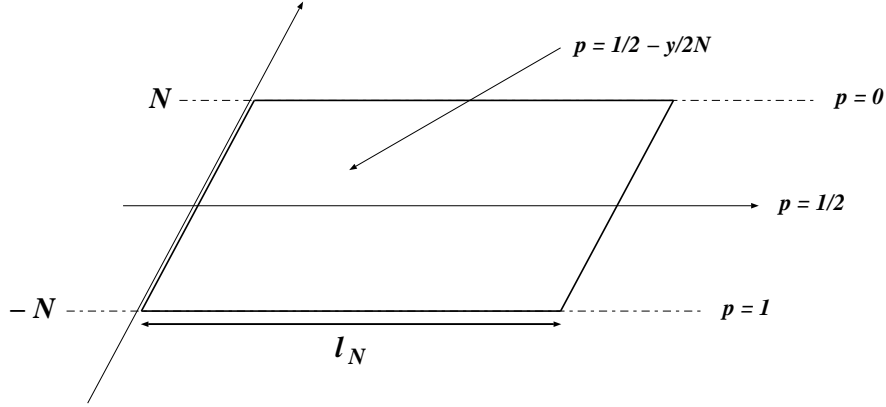

Figure 4: The strip where the percolation parameter p varies

we will denote it by \mathcal{R}_N . Note that the sites just above \mathcal{R}_N form a vacant horizontal crossing of \mathcal{S}_N , so that the upper boundary ρ_N of \mathcal{R}_N is a front. We shall see a little bit later that it is indeed *the* front (*i.e.* the only interface) with high probability.

We a priori expect it to be close to the line $\{y = 0\}$ corresponding to the sites where p is critical. A hand-waving argument goes as follows : if we are at a distance approximately $N^{4/7}$ of the line, say for instance above it, the corresponding parameter will be about $1/2 + N^{-3/7}$ and the associated characteristic length of order $N^{4/7}$ too. Hence, the strip on which everything looks like critical percolation has width of order $N^{4/7}$, and outside of this strip, one is in the super or sub-critical regime. This explains intuitively the following result.

Theorem 6 (Localization).

- For all $\delta > 0$, there exists a $\delta' > 0$ such that for all sufficiently large N and all $\ell_N \geq N^{4/7}$,

$$\mathbb{P}(\mathcal{R}_N \subseteq [\pm N^{4/7-\delta}]) \leq e^{-N^{\delta'}} \quad (13)$$

- For all $\delta > 0$, for all $\gamma \geq 1$, there exists a $\delta' > 0$ such that for all

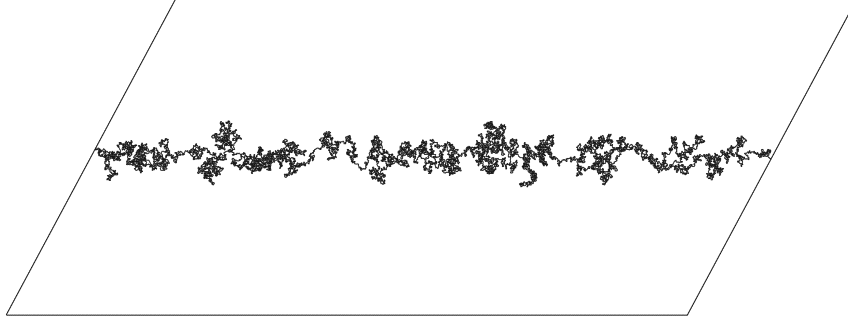

Figure 5: Localization of the front ($2N = 500$, $\ell_N = 1000$)

sufficiently large N , and all $N^{4/7} \leq \ell_N \leq N^\gamma$,

$$\mathbb{P}(\mathcal{R}_N \not\subseteq [\pm N^{4/7+\delta}]) \leq e^{-N^{\delta'}} \quad (14)$$

Proof. Let us first derive the statement concerning $\mathbb{P}(\mathcal{R}_N \subseteq [\pm N^{4/7-\delta}])$. For that purpose, consider disjoint rhombi of the form

$$[i, i + 2N^{4/7-\delta}] \times [-N^{4/7-\delta}, N^{4/7-\delta}] \quad (i = 0, 2N^{4/7-\delta} + 1, 4N^{4/7-\delta} + 2 \dots)$$

We can take at least $\ell_N/3N^{4/7-\delta}$ such rhombi, and each of them possesses (independently of the other ones) a vertical vacant crossing with probability larger than

$$\mathbb{P}_{1/2+N^{-3/7-\delta}/2}(\mathcal{C}_H^*([0, 2N^{4/7-\delta}]^2)).$$

But

$$L(1/2 + N^{-3/7-\delta}/2) \approx (N^{-3/7-\delta}/2)^{-4/3} \approx N^{4/7+4\delta/3},$$

hence

$$L(1/2 + N^{-3/7-\delta}/2) \gg 2N^{4/7-\delta},$$

so that there exists a vertical vacant crossing with probability larger than ϵ_0 . By independence, a “block” entailing that $\mathcal{R}_N \not\subseteq [\pm N^{4/7-\delta}]$, will occur with probability larger than

$$1 - (1 - \epsilon_0)^{\ell_N/3N^{4/7-\delta}},$$

which proves the claim as $\ell_N \geq N^{4/7}$ by assumption.

Let us now turn our attention to the quantity $\mathbb{P}(\mathcal{R}_N \not\subseteq [\pm N^{4/7+\delta}])$. Assume that \mathcal{R}_N is not entirely contained in the strip $[\pm N^{4/7+\delta}]$.

If at some point it is for example above this strip, we face the following alternative :

- Either \mathcal{R}_N stays constantly above the strip $[\pm N^{4/7+\delta}/2]$, *i.e.* in the parallelogram $[0, \ell_N] \times [N^{4/7+\delta}/2, N]$, where the percolation parameter remains lower than $1/2 - N^{-3/7+\delta}/4$. As $\ell_N \geq N^{4/7}$, this event occurs with probability less than

$$\mathbb{P}_{1/2 - N^{-3/7+\delta}/4}(\mathcal{C}_H([0, N^{4/7}]^2)).$$

Lemma 2 (of sub-exponential decay) entails that this quantity is less than

$$C e^{-N^{4/7}/L(1/2 - N^{-3/7+\delta}/4)}$$

But (critical exponent for L)

$$L(1/2 - N^{-3/7+\delta}/4) \approx (N^{-3/7+\delta}/4)^{-4/3} \approx N^{4/7-4\delta/3} \ll N^{4/7-\delta},$$

so that the obtained probability tends to 0 sub-exponentially fast.

- Either \mathcal{R}_N is in the strip $[\pm N^{4/7+\delta}/2]$ at some point. In that case, consider the following rhombi, located between the lines $y = N^{4/7+\delta}/2$ and $y = N^{4/7+\delta}$: $[i, i + N^{4/7+\delta}/2] \times [N^{4/7+\delta}/2, N^{4/7+\delta}]$ ($i = 0, 1, 2, \dots$). It is easy to see that \mathcal{R}_N will have to cross vertically *or horizontally* one of them.

There are at most ℓ_N such rhombi, and they are in a zone for which $p \leq 1/2 - N^{-3/7+\delta}/4$, a crossing thus occurs with probability less than

$$\begin{aligned} & \ell_N \mathbb{P}_{1/2 - N^{-3/7+\delta}/4}(\mathcal{C}_H([0, N^{4/7+\delta}/2]^2) \cup \mathcal{C}_V([0, N^{4/7+\delta}/2]^2)) \\ & \leq 2\ell_N \mathbb{P}_{1/2 - N^{-3/7+\delta}/4}(\mathcal{C}_H([0, N^{4/7+\delta}/2]^2)) \\ & \leq 2C \ell_N e^{-N^{4/7+\delta}/2L(1/2 - N^{-3/7+\delta}/4)} \end{aligned}$$

by using once again Lemma 2.

As before,

$$L(1/2 - N^{-3/7+\delta}/4) \approx (N^{-3/7+\delta}/4)^{-4/3} \approx N^{4/7-4\delta/3},$$

and ℓ_N does not grow too fast, so that the last probability tends to 0 sub-exponentially fast.

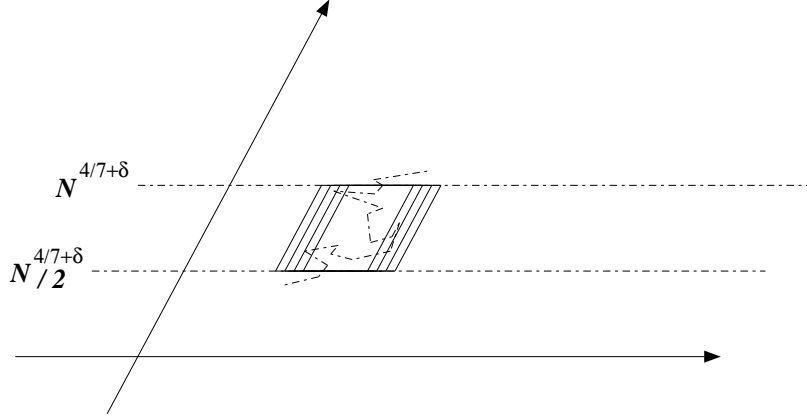

Figure 6: \mathcal{R}_N crosses horizontally or vertically one of the small rhombi

If \mathcal{R}_N is below the strip at some point, the reasoning is the same : consider instead the vacant crossing bordering \mathcal{R}_N . Hence, the final probability just has to be multiplied by 2.

□

3.3 Uniqueness of the front

In the previous subsection, we have focused on the highest horizontal crossing \mathcal{R}_N . Clearly, the results remain valid if we consider the lowest horizontal vacant crossing \mathcal{R}_N^* instead. Recall that \mathcal{R}_N is bordered above by a horizontal vacant crossing, so that its upper boundary ρ_N is a front. Similarly, \mathcal{R}_N^* is bordered below by an occupied crossing, and its lower boundary ρ_N^* is a front too.

Note that ρ_N^* is always below ρ_N . It is easy to see that uniqueness of the front amounts to checking whether ρ_N and ρ_N^* coincide. It is also equivalent to verifying that \mathcal{R}_N is connected to the bottom \mathcal{B}_N by an occupied path (or that \mathcal{R}_N^* is connected to the top \mathcal{T}_N by a vacant path). We are now going to prove that this indeed occurs with a very large probability.

Note that if one starts an exploration process from the top-left corner of \mathcal{S}_N , one discovers the top-most occupied crossing without discovering the status of the sites below it. This RSW-type observation will be essential in our proof.

Proposition 7 (Uniqueness). *Assume that $\ell_N \geq N^{4/7+\delta}$ for some $\delta > 0$. Then, there is a $\delta' > 0$ (depending on δ) such that for all sufficiently large N ,*

$$\mathbb{P}(\rho_N = \rho_N^*) \geq 1 - e^{-N^{\delta'}} \quad (15)$$

Proof. As announced, we will work with \mathcal{R}_N . Our goal is to show that the probability for \mathcal{R}_N not to be connected to \mathcal{B}_N is very small. For that purpose, we first divide the strip \mathcal{S}_N into disjoint sub-strips (\mathcal{S}_N^i) as follows. For $\epsilon := \delta/4$, we choose $N^{3\epsilon}/6$ disjoint sub-strips of length $3N^{4/7+\epsilon}$ (not necessarily covering entirely \mathcal{S}_N) of the type

$$\mathcal{S}_N^i = [n_N^i, n_N^i + 3N^{4/7+\epsilon}] \times [-N, N] \quad (i = 0, \dots, N^{3\epsilon}/6 - 1).$$

Consider one of these strips \mathcal{S}_N^i . \mathcal{R}_N crosses it horizontally, and remains “below” its highest horizontal crossing, that we denote by r_N^i . Consequently, it will be sufficient to show that one of the r_N^i ’s is connected to \mathcal{B}_N in \mathcal{S}_N^i .

We now fix an i , and we try to find a lower bound for the probability that r_N^i is connected to the bottom of \mathcal{S}_N^i by an occupied path that stays in that sub-strip. Let us suppose for notational convenience that $i = 0$ and $n_N^i = 0$. Note first that with probability at least $1/2$, there exists a vacant top-to-bottom crossing of the rhombus $[N^{4/7+\epsilon}, 2N^{4/7+\epsilon}] \times [0, N^{4/7+\epsilon}]$ (percolation is sub-critical in this region), so that a lowest point z on r_N^i in the middle part $[N^{4/7+\epsilon}, 2N^{4/7+\epsilon}] \times [-N, N]$ of the strip lies below the x -axis with probability at least $1/2 + o(1)$ (the localization result (Theorem 6) tells us that r_N^i remains below the height $N^{4/7+\epsilon}$ with high probability).

Now, if we have explored this highest crossing of \mathcal{S}_N^0 “from above”, we have not yet discovered the status of the sites below it, so that we can apply the FKG inequality for events involving only the state of these remaining sites. We are now going to show that in the case where r_N^0 passes below the x -axis, the conditional probability that it is connected to the bottom part of the sub-strip by an occupied crossing is bounded from below by a quantity of order $N^{-2\epsilon}$.

A way to prove this goes as follows. Let us first choose z , and define the annulus $S(z, 2N^{4/7-\epsilon}) \setminus \mathring{S}(z, N^{4/7-\epsilon})$ around z . Since it is contained in the region where $p \geq 1/2 - 2N^{-3/7-\epsilon}$, and since the characteristic length corresponding to this value of the parameter is of order

$$L(1/2 - 2N^{-3/7-\epsilon}) \approx N^{4/7+4\epsilon/3},$$

there is a probability at least δ_4^4 (this is the constant coming from RSW-theory) to observe an occupied circuit in this annulus.

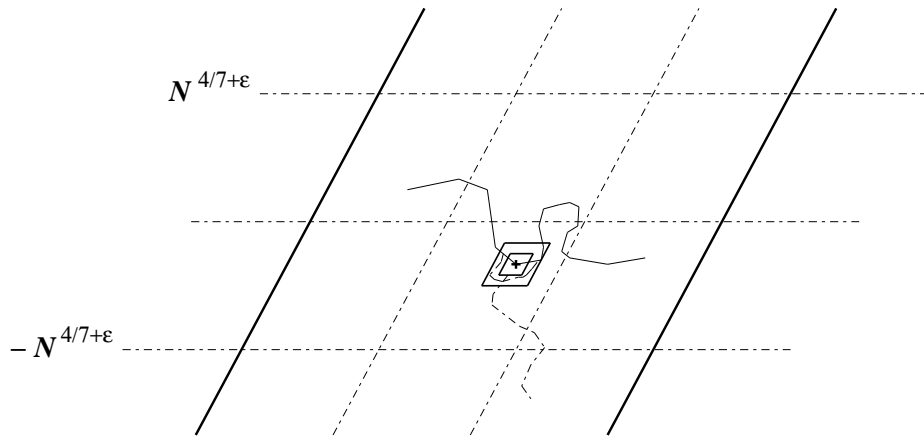

Figure 7: Construction of an arm going out of $[\pm N^{4/7+\epsilon}]$

We now want to connect this circuit to the bottom boundary of the sub-strip. Note that the part of the circuit that is below r_N^0 together with r_N^0 contain an occupied circuit around the segment $I = z + [-N^{4/7-\epsilon}, N^{4/7-\epsilon}] \times \{-N^{4/7-\epsilon}\}$. We need the following simple lemma for critical percolation:

Lemma 8. *Consider the rhombus $[-N^{4/7+\epsilon}, N^{4/7+\epsilon}] \times [-2N^{4/7+\epsilon}, 0]$ and the sub-interval $I_N = [-N^{4/7-\epsilon}, N^{4/7-\epsilon}] \times \{0\}$ on its top edge. Then the event $\mathcal{C}_V^{I_N}([-N^{4/7+\epsilon}, N^{4/7+\epsilon}] \times [-2N^{4/7+\epsilon}, 0])$ that there exists a vertical occupied crossing connecting I_N to the bottom edge has a probability at least*

$$\mathbb{P}_{1/2}[\mathcal{C}_V^{I_N}([-N^{4/7+\epsilon}, N^{4/7+\epsilon}] \times [-2N^{4/7+\epsilon}, 0])] \geq \frac{C}{N^{2\epsilon}} \quad (16)$$

for some universal constant C (depending neither on N nor on ϵ).

Proof. Consider the parallelogram $[0, N^{4/7+\epsilon}] \times [-2N^{4/7+\epsilon}, 0]$, and cover its top edge by less than $N^{2\epsilon}$ intervals $I_N^j = [n_N^j - N^{4/7-\epsilon}, n_N^j + N^{4/7-\epsilon}] \times \{0\}$ of length $2N^{4/7-\epsilon}$. We know from RSW theorem that there exists a vertical occupied crossing with probability at least $\delta_2 > 0$, so that

$$\delta_2 \leq \sum_j \mathbb{P}_{1/2}[\mathcal{C}_V^{I_N^j}([0, N^{4/7+\epsilon}] \times [-2N^{4/7+\epsilon}, 0])]$$

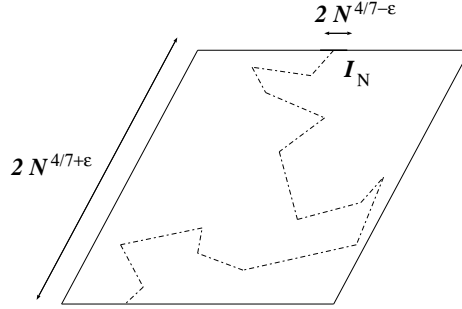

Figure 8: Existence of an arm from I_N to the bottom side

But for each j ,

$$\begin{aligned}
& \mathbb{P}_{1/2} [\mathcal{C}_V^{I_N^j} ([0, N^{4/7+\epsilon}] \times [-2N^{4/7+\epsilon}, 0])] \\
& \leq \mathbb{P}_{1/2} [\mathcal{C}_V^{I_N^j} ([n_N^j - N^{4/7+\epsilon}, n_N^j + N^{4/7+\epsilon}] \times [-2N^{4/7+\epsilon}, 0])] \\
& = \mathbb{P}_{1/2} [\mathcal{C}_V^{I_N} ([-N^{4/7+\epsilon}, N^{4/7+\epsilon}] \times [-2N^{4/7+\epsilon}, 0])]
\end{aligned}$$

by translation invariance. Hence

$$\delta_2 \leq N^{2\epsilon} \times \mathbb{P}_{1/2} [\mathcal{C}_V^{I_N} ([-N^{4/7+\epsilon}, N^{4/7+\epsilon}] \times [-2N^{4/7+\epsilon}, 0])],$$

which completes the proof. Note that a repeated application of the RSW theorem ($\log(N^{2\epsilon})$ times) would have given a lower bound of the type $N^{-k\epsilon}$ that would have been also sufficient for our purpose here. \square

Putting the pieces together, with the help also of the FKG inequality, we get that for each $i \leq N^{3\epsilon}/6 - 1$, on the event that \mathcal{R}_N remains localized, the probability that it is connected to the bottom part of the strip in the sub-strip \mathcal{S}_N^i is bounded from below by $C'/N^{2\epsilon}$ independently for each i . The proposition then follows readily : indeed, \mathcal{R}_N is connected to \mathcal{B}_N with probability at least

$$1 - (1 - C'N^{-2\epsilon})^{N^{3\epsilon}/6} \geq 1 - e^{-N^{\epsilon'}} \tag{17}$$

for some positive ϵ' . \square

Remark 9. *The previous results suggest to make some restrictions about the length ℓ_N of the strip. In the following, we will thus assume that $\ell_N = o(N^\gamma)$*

for some $\gamma \geq 1$ (to ensure convergence), and that there exists a $\delta > 0$ such that $\ell_N \geq N^{4/7+\delta}$ (to ensure uniqueness). This second hypothesis entails that the event corresponding to uniqueness has a probability tending to 1 sub-exponentially fast, so that we can restrict to it.

From now on, we will simply refer to the front and denote it by \mathcal{F}_N , which means that we will implicitly neglect the error term in the estimates that we derive.

4 Length of the front

We would like now to study the length T_N of the front *i.e.* its number of edges. For that purpose, we will need a two-arm probability estimate. Unless otherwise stated, the expression “two arms” refers to two arms of *opposite color*.

We will often have to count edges rather than sites. Since we are mostly interested in rough estimates, we will then just use the fact that number of edges and number of corresponding sites are comparable (*i.e.* up to a multiplicative factor of 6). To simplify notations, it will be convenient to associate to each edge e one of its two neighboring sites x_e , which we do arbitrarily and once for all.

4.1 Two-arm estimates

We are now going to derive the analog of (5) in the case of two arms and for non-constant p . The goal is to show roughly that

$$\mathbb{P}_p[A_2(2, n)] \asymp \mathbb{P}_{1/2}[A_2(2, n)] \quad (n \leq L(p))$$

In fact, for our purpose, we will have to consider, instead of \mathbb{P}_p , product measures P' with associated parameters $p'(v)$ which may depend on the site v but remain between p and $1 - p$ (we will simply say that P' is “between p and $1 - p$ ”). The present situation is a little more complicated than for the one-arm estimate, because of the lack of monotonicity (A_2 events correspond to the combination of one path of each type, so that they are neither increasing nor decreasing).

For a parallelogram R containing 0 in its interior, we denote by $\Gamma_2(0, R)$ the event that there exist an occupied path r_1 and a vacant path r_2 from 0 to the boundary ∂R of R (this is the analog to $\Gamma(0, R)$ in Kesten’s paper [16], that corresponds to the existence of 4 arms alternatively occupied and vacant). Let us now state and prove the result:

Lemma 10. *Uniformly in p , \hat{P} between p and $1 - p$, $n \leq L(p)$, we have*

$$\hat{P}[\Gamma_2(0, S(n))] \asymp \mathbb{P}_{1/2}[\Gamma_2(0, S(n))] \quad (18)$$

Proof. This proof is an adaptation of the proof of Theorem 1 in Kesten’s paper [16]. We first recall some estimates contained in this paper, and then we adapt the original proof for 1 arm to the case of 2 arms. Note that Lemma 8 in [16] is the “four-arm” version of this two-arm result.

Let us first introduce the events that we use throughout the proof. All of them are exact analogs of events defined in Kesten’s paper [16].

- In the case of 1 arm, we do not lose much (a factor 4) by imposing the extremity to be on a specified edge. Here we impose the occupied arm to arrive on the bottom edge and the vacant arm on the top edge. This event is denoted by $\Omega_2(0, R)$.
- This event is a bit difficult to extend, so we may want to add furthermore “security strips”. This leads to the definition of the event Δ_2 , analog of the event Δ (in the case of 4 arms). Albeit more restrictive, this event has a probability that remains comparable to $\Omega_2(0, R)$.

We consider thus the two horizontal strips

$$\begin{aligned} \mathcal{A}(1, k) &:= [-2^{k-1}, 2^{k-1}] \times [-2^k, -2^{k-1}] \\ \mathcal{A}(2, k) &:= [-2^{k-1}, 2^{k-1}] \times [2^{k-1}, 2^k] \end{aligned}$$

and we define for a site v in $S(2^{k-1})$,

$$\Delta_2(v, S(2^k)) = \{\Gamma_2(v, S(2^k)) \text{ occurs, with } r_i \cap (S(2^k) \setminus \mathring{S}(2^{k-1})) \subseteq \mathcal{A}(i, k) \text{ and there exist two horizontal crossings, one occupied of } \mathcal{A}(1, k) \text{ and one vacant of } \mathcal{A}(2, k)\}.$$

- We define similarly for a parallelogram R contained in the interior of $S(2^k)$:

$$\tilde{\Gamma}_2(S(2^k), R) = \{\text{There exist an occupied path } r_1 \text{ and a vacant path } r_2 \text{ from } \partial R \text{ to the bottom and top edges respectively of } S(2^k), \text{ which are (with the exception of their extremities on } \partial R) \text{ contained in } S(2^k) \setminus R\}.$$

and for a site v in $S(2^{k-1})$, $j \leq k - 2$, the following strips (centered on v):

$$\tilde{\mathcal{A}}(1, j) := [v(1) - 2^j, v(1) + 2^j] \times [v(2) - 2^{j+1}, v(2) - 2^j]$$

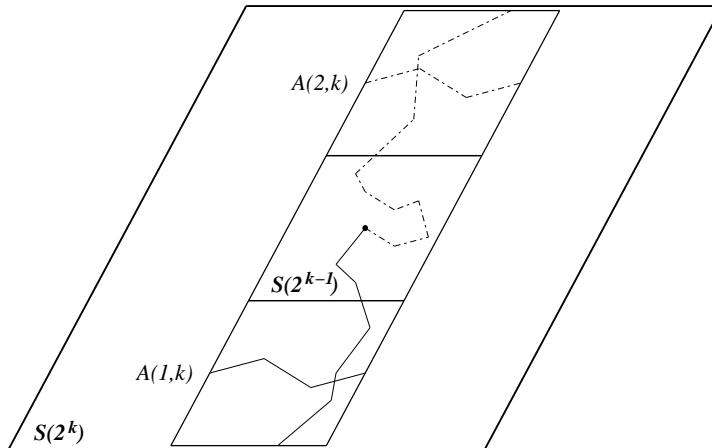

Figure 9: Definition of the event Δ_2

$$\tilde{\mathcal{A}}(2, j) := [v(1) - 2^j, v(1) + 2^j] \times [v(2) + 2^j, v(2) + 2^{j+1}]$$

and then

$\tilde{\Delta}_2(S(2^k), S(v, 2^j)) = \{\tilde{\Gamma}_2(S(2^k), S(v, 2^j))$ occurs, with associated paths r_i satisfying $r_i \cap (S(v, 2^{j+1}) \setminus \hat{S}(v, 2^j)) \subseteq \tilde{\mathcal{A}}(i, j)$, and there exist two horizontal crossings, one occupied of $\tilde{\mathcal{A}}(1, j)$ and one vacant of $\tilde{\mathcal{A}}(2, j)\}$.

Let us now state the estimates that we will use. We will not prove them, since these are exact analogs for 2 arms of results stated for 4 arms in Kesten’s paper [16], except that we generalize the condition “between p and $1/2$ ” to “between p and $1 - p$ ”. This generalization can be done as the only tool used in the proofs is Russo-Seymour-Welsh theorem (we also implicitly use the symmetry, which implies that $L(p) = L(1 - p)$). In the following, \hat{P} denotes any product measure “between p and $1 - p$ ”.

- (1) **Extension of Δ_2** : There exists a constant $C_1 < \infty$ such that

$$\hat{P}(\Delta_2(0, S(2^k))) \leq C_1 \hat{P}(\Delta_2(0, S(2^{k+1}))) \quad (19)$$

for all $2^k \leq L(p)$.

- (2) **Comparison of Γ_2 and Δ_2** (analog of Lemma 4 in [16]) : There exists a constant $C_2 < \infty$ such that

$$\hat{P}(\Gamma_2(0, S(2^k))) \leq C_2 \hat{P}(\Delta_2(0, S(2^k))) \quad (20)$$

for all $2^k \leq L(p)$.

- (3) **Comparison of $\tilde{\Gamma}_2$ and $\tilde{\Delta}_2$** (analog of Lemma 5 in [16]) : There exists a constant $C_3 < \infty$ such that

$$\hat{P}(\tilde{\Gamma}_2(S(2^k), S(2^j))) \leq C_3 \hat{P}(\tilde{\Delta}_2(S(2^k), S(2^j))) \quad (21)$$

for all $2^k \leq L(p)$ and $j \leq k - 2$.

These prerequisites being recalled, we are now able to turn to the proof itself. For that purpose, we will have to adapt Kesten's original proof. Recall that we consider a parameter p , a measure \hat{P} between p and $1 - p$ and an integer $n \leq L(p)$. The parameters of \hat{P} will be denoted by $p(v)$.

1st step : We first notice that we can replace $\Gamma_2(0, S(n))$ by $\Omega_2(0, S(2^k))$, with k such that $2^k \leq n < 2^{k+1}$. Indeed, the previous results entail

$$\begin{aligned} \hat{P}(\Gamma_2(0, S(n))) &\geq \hat{P}(\Gamma_2(0, S(2^{k+1}))) \geq \hat{P}(\Delta_2(0, S(2^{k+1}))) \\ &\geq C_1^{-1} \hat{P}(\Delta_2(0, S(2^k))) \\ &\geq C_2^{-1} C_1^{-1} \hat{P}(\Gamma_2(0, S(2^k))) \geq C_2^{-1} C_1^{-1} \hat{P}(\Omega_2(0, S(2^k))) \end{aligned}$$

and

$$\begin{aligned} \hat{P}(\Omega_2(0, S(2^k))) &\geq \hat{P}(\Delta_2(0, S(2^k))) \\ &\geq C_2^{-1} \hat{P}(\Gamma_2(0, S(2^k))) \geq C_2^{-1} \hat{P}(\Gamma_2(0, S(n))) \end{aligned}$$

2nd step : We would like now to use Russo's formula, but for technical reasons which will become clear in the next step, this will work nicely only for the points that are not too close to the boundary. We therefore first have to see how the change of $p(v)$ for the points that are close to the boundary affects the probabilities that we investigate. More precisely, we start with $\mathbb{P}_{1/2}$ and change $1/2 \rightsquigarrow p(v)$ only in $S(2^k) \setminus S(2^{k-3})$. The resulting measure \tilde{P} is between p and $1 - p$: so,

$$\mathbb{P}_{1/2}(\Omega_2(0, S(2^k))) \asymp \mathbb{P}_{1/2}(\Delta_2(0, S(2^k))) \asymp \mathbb{P}_{1/2}(\Delta_2(0, S(2^{k-3})))$$

thanks to (19), and similarly

$$\tilde{P}(\Omega_2(0, S(2^k))) \asymp \tilde{P}(\Delta_2(0, S(2^{k-3}))),$$

which allows us to conclude, since $\mathbb{P}_{1/2}(\Delta_2(0, S(2^{k-3}))) = \tilde{P}(\Delta_2(0, S(2^{k-3})))$ by definition.

3rd step : In order to handle the sites v located in $S(2^{k-3})$, we will apply a generalization of Russo's formula to the family of measures $(\hat{P}_t)_{t \in [0,1]}$ with parameters

$$p(v, t) = tp(v) + (1 - t)/2,$$

which corresponds to a linear interpolation between $1/2 \rightsquigarrow p(v)$ in $S(2^{k-3})$. The event $\Omega_2(0, S(2^k))$ can be written as the intersection of $A_2(0, S(2^k)) = \{\text{There exists an occupied path from } 0 \text{ to the bottom side of } \partial S(2^k)\}$ and $B_2(0, S(2^k)) = \{\text{There exists a vacant path from } 0 \text{ to the top side of } S(2^k)\}$. These two events are respectively increasing and decreasing, and in that case, $\frac{d}{dt} \hat{P}_t(A_2 \cap B_2)$ can be expressed as (see Lemma 1 in [16]):

$$\sum_{v \in S(2^{k-3})} \frac{dp(v, t)}{dt} [\hat{P}_t(v \text{ is pivotal for } A_2, \text{ but not for } B_2, \text{ and } B_2 \text{ occurs}) \\ - \hat{P}_t(v \text{ is pivotal for } B_2, \text{ but not for } A_2, \text{ and } A_2 \text{ occurs})]$$

A vertex $v \in S(2^{k-3})$ is pivotal for A_2 iff there exists a path containing v , all sites of which, except v , are vacant, and separating 0 from the bottom side of $S(2^k)$. In the case of 1 arm, Kesten used a vacant loop around the origin, here the path can have its extremities on the boundary. This will not change the computations, since we still have 4 arms locally, that we will sum in the same way.

Actually, we must also assume that $k \geq 7$ and put apart the vertices which are too close to the origin, for instance those in $S(16)$. For these sites,

$$\hat{P}_t(v \text{ is pivotal for } A_2, \text{ but not for } B_2, \text{ and } B_2 \text{ occurs}) \leq C_5 \hat{P}_t(\Omega_2(0, S(2^k)))$$

for some universal constant C_5 .

We now associate to each site $v \in S(2^{k-3}) \setminus S(16)$ a parallelogram $R(v)$ such that $0 \notin R(v)$, so that we make appear four arms locally (we explain how to choose these parallelograms later):

$$\begin{aligned} & \hat{P}_t(v \text{ is pivotal for } A_2, \text{ but not for } B_2, \text{ and } B_2 \text{ occurs}) \\ & \leq \hat{P}_t[\Gamma_2(0, R(v)) \cap \Gamma(v, R(v)) \cap \tilde{\Gamma}_2(S(2^k), R(v))] \\ & = \hat{P}_t[\Gamma_2(0, R(v))] \hat{P}_t[\Gamma(v, R(v))] \hat{P}_t[\tilde{\Gamma}_2(S(2^k), R(v))] \end{aligned}$$

by independence (these events depending on sites in disjoint sets).

As for the choice of the parallelograms $R(v)$, we can take them like in Kesten's paper (see [16] p. 117). As noticed in this paper, the precise choice is not really important. On one hand, we have to ensure that the four arms are not too small. For that purpose, the distances between v and each of the sides of $R(v)$ must be comparable to the distance between 0 and v . On the other hand, the paths outside $R(v)$, respectively between 0 and ∂R , and between ∂R and $\partial S(2^k)$, must not be too short. For the sake of completeness, let us just recall briefly how Kesten chooses these $R(v)$. Consider $v = (v_1, v_2) \notin S(16)$. If $|v_1| \leq |v_2| \leq 2^{k-3}$ and $16 \leq 2^{j+1} < v_2 \leq 2^{j+2}$, take l_1 and l_2 such that

$$l_1 2^{j-2} < v_1 \leq (l_1 + 1) 2^{j-2} \quad \text{and} \quad l_2 2^{j-2} < v_2 \leq (l_2 + 1) 2^{j-2},$$

and define

$$R(v) = [(l_1 - 2) 2^{j-2}, (l_1 + 2) 2^{j-2}] \times [l_2 2^{j-2} - 2^j, l_2 2^{j-2} + 2^j].$$

If $v_2 < 0$, take the image of $R((v_1, -v_2))$ by the symmetry with respect to the x -axis. Finally, if $|v_2| < |v_1|$, simply exchange the roles of the first and second coordinates.

Note that these parallelograms possess by construction the following property : if j is such that $2^{j+1} < d(v, 0) \leq 2^{j+2}$, then $R(v)$ is included in $\hat{S}(2^{j+3}) \setminus S(2^j)$. Consequently,

$$\begin{aligned} \hat{P}_t(v \text{ is pivotal for } A_2, \text{ but not for } B_2, \text{ and } B_2 \text{ occurs}) \\ \leq \hat{P}_t[\Gamma_2(0, S(2^j))] \hat{P}_t[\Gamma(v, R(v))] \hat{P}_t[\tilde{\Gamma}_2(S(2^k), S(2^{j+3}))] \end{aligned}$$

Now, by joining the two terms $\hat{P}_t[\Gamma_2(0, S(2^j))]$ and $\hat{P}_t[\tilde{\Gamma}_2(S(2^k), S(2^{j+3}))]$, we can make appear $\hat{P}_t[\Omega_2(0, S(2^k))]$: indeed, we get easily from Russo-Seymour-Welsh theorem (see Lemma 6 in [16])

$$\delta_{16}^2 \hat{P}_t[\Delta_2(0, S(2^j))] \hat{P}_t[\tilde{\Delta}_2(S(2^k), S(2^{j+3}))] \leq \hat{P}_t[\Delta_2(0, S(2^k))]$$

for all $2^k \leq L(p)$ and $j \leq k - 5$ (here a slight generalization of the FKG inequality is needed (see for instance Lemma 3 in [16]), invoking zones where "everything is monotonous").

We obtain then from

$$\hat{P}_t[\Delta_2(0, S(2^j))] \geq C_2^{-1} \hat{P}_t[\Gamma_2(0, S(2^j))]$$

(which follows from (20)), and

$$\hat{P}_t[\tilde{\Delta}_2(S(2^k), S(2^{j+3}))] \geq C_3^{-1} \hat{P}_t[\tilde{\Gamma}_2(S(2^k), S(2^{j+3}))]$$

(using (21)), that

$$\begin{aligned} \hat{P}_t[\Gamma_2(0, S(2^j))] \hat{P}_t[\tilde{\Gamma}_2(S(2^k), S(2^{j+3}))] &\leq C_4 \hat{P}_t[\Delta_2(0, S(2^k))] \\ &\leq C_4 \hat{P}_t[\Omega_2(0, S(2^k))] \end{aligned}$$

Now, dividing by this last term will make appear its logarithmic derivative in the left-hand side :

$$\begin{aligned} &\frac{d}{dt} \log [\hat{P}_t(\Omega_2(0, S(2^k)))] \\ &\leq C_6 \sum_{v \in S(2^{k-3}) \setminus S(16)} \left| \frac{dp(v, t)}{dt} \right| \hat{P}_t[\Gamma(v, R(v))] + C_5 \sum_{v \in S(16)} \left| \frac{dp(v, t)}{dt} \right| \end{aligned}$$

Finally, the first term that we obtain (the sum encoding the existence of 4 arms locally) is exactly the same as in Kesten's paper [16] (end of the proof of Theorem 1 p. 140), and its integral between 0 and 1 is bounded by some universal constant C_7 :

$$\int_0^1 \left(\sum_{v \in S(2^{k-3}) \setminus S(16)} \left| \frac{dp(v, t)}{dt} \right| \hat{P}_t[\Gamma(v, R(v))] \right) dt \leq C_7$$

The desired conclusion then follows. \square

4.2 Expected length of the front

With this result established, we are now able to study properties of the front in the “critical strip”. We have the following estimate concerning the expectation of T_N :

Proposition 11. *For all $\delta > 0$, we have for N sufficiently large:*

$$N^{3/7-\delta} \ell_N \leq \mathbb{E}[T_N] \leq N^{3/7+\delta} \ell_N \quad (22)$$

Proof. Throughout the proof, we will use the fact that

$$\mathbb{E}[T_N] = \sum_{e \in \mathcal{S}_N} \mathbb{P}(e \in \mathcal{F}_N) \quad (23)$$

We consider first the upper bound. Take $\epsilon = \delta/4$: we have

$$\mathbb{E}[T_N] \leq 6|\mathcal{S}_N| \times \mathbb{P}(\mathcal{F}_N \not\subseteq [\pm N^{4/7+\epsilon}]) + \sum_{e \subseteq [\pm N^{4/7+\epsilon}]} \mathbb{P}(e \in \mathcal{F}_N)$$

and it follows from localization and the fact that $|\mathcal{S}_N| = (2N+1) \times (\ell_N+1) = o(N^{\gamma+1})$, that the first term tends to 0 sub-exponentially fast. We can thus restrict the summation to the vertices in the strip $[\pm N^{4/7+\epsilon}]$.

But for $e \subseteq [\pm N^{4/7+\epsilon}]$,

$$\mathbb{P}(e \in \mathcal{F}_N) \leq \mathbb{P}[2 \text{ arms } x_e \rightsquigarrow \partial S(x_e, N^{4/7-2\epsilon})]$$

and as $S(x_e, N^{4/7-2\epsilon}) \subseteq [\pm 2N^{4/7+\epsilon}]$, the parameter in this box remains in the range $[1/2 \pm 2N^{-3/7+\epsilon}]$. The associated characteristic length being

$$L(1/2 \pm 2N^{4/7+\epsilon}) \approx N^{4/7-4\epsilon/3} \gg N^{4/7-2\epsilon},$$

we get

$$\begin{aligned} \mathbb{P}[2 \text{ arms } x_e \rightsquigarrow \partial S(x_e, N^{4/7-2\epsilon})] & \\ & \asymp \mathbb{P}_{1/2}[2 \text{ arms } x_e \rightsquigarrow \partial S(x_e, N^{4/7-2\epsilon})] \\ & \approx (N^{4/7-2\epsilon})^{-1/4} \quad (\text{by using the 2-arm exponent}) \\ & \ll N^{-1/7+\epsilon} \end{aligned}$$

Now we just have to sum this inequality to get the desired result : for N large enough,

$$\begin{aligned} \sum_{e \subseteq [\pm N^{4/7+\epsilon}]} \mathbb{P}(e \in \mathcal{F}_N) & \leq 6(2N^{4/7+\epsilon} + 1)(\ell_N + 1) \times N^{-1/7+\epsilon} \\ & \leq N^{3/7+\delta} \ell_N \end{aligned}$$

Let us turn now to the lower bound. We restrict to the edges e in the strip $[2N^{4/7+\epsilon}, \ell_N - 2N^{4/7+\epsilon}] \times [\pm N^{4/7-\epsilon}]$, with $\epsilon = \delta/6$. For such edges, we would like to estimate the probability of having two arms, one occupied to \mathcal{B}_N and one vacant to \mathcal{T}_N , we will so use the event Δ_2 rather than Γ_2 .

Take j such that $N^{4/7-\epsilon} < 2^j \leq 2N^{4/7-\epsilon}$: the probability of having two arms, one occupied to the bottom of $\partial S(x_e, N^{4/7-\epsilon})$, and one vacant to the top, is at least

$$\mathbb{P}(\Delta_2(x_e, S(x_e, 2^j))) \asymp \mathbb{P}(\Gamma_2(x_e, S(x_e, 2^j)))$$

Since we stay in the strip $[\pm 3N^{4/7-\epsilon}]$, of associated characteristic length $L(1/2 \pm 3N^{-3/7-\epsilon}) \approx N^{4/7+4\epsilon/3}$, we get that this probability is of the same order as

$$\mathbb{P}_{1/2}(\Gamma_2(x_e, S(x_e, 2^j))) \approx (2^j)^{-1/4} \quad (\text{2-arm exponent}) \quad (24)$$

which (for N sufficiently large) is greater than

$$(N^{4/7-\epsilon})^{-1/4} \gg N^{-1/7} \quad (25)$$

We now have to join these two paths to the boundaries of the strip. By the same reasoning as for the existence of \mathcal{F}_N , on the top edge of $[0, N^{4/7+\epsilon}]^2$, there is a sub-interval I of length 2^j such that there exists an occupied vertical crossing from I to the bottom edge with probability at least

$$\mathbb{P}_{1/2}[\mathcal{C}_V^I([0, N^{4/7+\epsilon}]^2)] \geq N^{-2\epsilon}/4 \quad (26)$$

which implies that we can construct two arms going out of the strip $[\pm N^{4/7+\epsilon}]$ with probability at least $N^{-1/7-5\epsilon}$ (for N large enough). Then, we just have to use the fact that in that case, the probability of not being connected to the top and to the bottom tends to 0 sub-exponentially fast. The conclusion follows, by summing the lower bound over all edges e in the strip $[\pm N^{4/7-\epsilon}]$. \square

4.3 Convergence in L^2

Here everything happens in the strip $[\pm N^{4/7}]$, and it is possible to determine whether or not an edge e is on the front on a vicinity of order $N^{4/7}$ (with probability very close to 1). Distant points will thus be almost completely decorrelated, and there is a phenomenon of “averaging”. More precisely, we get the following bound on $\text{Var}[T_N]$:

Proposition 12. *For each $\delta > 0$, we have for N sufficiently large:*

$$\text{Var}[T_N] \leq N^{11/7+\delta} \ell_N \quad (27)$$

By combining this result to the estimates on $\mathbb{E}[T_N]$ of the previous subsection, we immediately get that if $\ell_N \geq N^{5/7+\delta}$ for some $\delta > 0$, then

$$\text{Var}[T_N] = o(\mathbb{E}[T_N]^2) \quad (28)$$

and consequently

Theorem 13. *If for some $\delta > 0$, $\ell_N \geq N^{5/7+\delta}$, then*

$$\frac{T_N}{\mathbb{E}[T_N]} \longrightarrow 1 \quad \text{in } L^2, \text{ when } N \rightarrow \infty \quad (29)$$

Remark 14. *On each vertical line, amongst the (about) $N^{4/7}$ edges which lay in the critical strip, approximately $N^{3/7}$ of them will be on the front, that is one over $N^{1/7}$. If we take ℓ_N to be equal to N , we get $\mathbb{E}[T_N] \sim N^{10/7}$, and this exponent can indeed be observed numerically.*

Proof. For an edge e , the event “ $e \in \mathcal{F}_N$ ” will be denoted by F_e . Using the expression

$$T_N = \sum \mathbb{I}_{F_e} \quad (30)$$

we get

$$\text{Var}[T_N] = \sum_{e,f} [\mathbb{P}(F_e \cap F_f) - \mathbb{P}(F_e)\mathbb{P}(F_f)] \quad (31)$$

First, notice that we can restrict the summation to the edges $e, f \subseteq [\pm N^{4/7+\delta}]$: like before, the remaining term tends to 0 sub-exponentially fast.

The idea is to replace F_e by an event \tilde{F}_e which depends only on sites in a box around e of size $N^{4/7+\delta}$, and such that $\mathbb{P}(F_e \Delta \tilde{F}_e) \rightarrow 0$ sub-exponentially fast. To construct such an event, we simply invoke the result of uniqueness, which implies that we can take

$$\tilde{F}_e := \{ 2 \text{ arms } e \rightsquigarrow \text{ top and bottom sides of } \partial S(x_e, N^{4/7+\delta}) \} \quad (32)$$

We have thus

$$\text{Var}[T_N] = \sum_e \sum_f [\mathbb{P}(\tilde{F}_e \cap \tilde{F}_f) - \mathbb{P}(\tilde{F}_e)\mathbb{P}(\tilde{F}_f)] + \epsilon_N$$

with an error term ϵ_N tending to 0 sub-exponentially fast.

Now, for an edge e , there are at most $6(2N^{4/7+\delta} + 1)^2$ edges f for which the two associated boxes intersect, and in that case,

$$\mathbb{P}(\tilde{F}_e \cap \tilde{F}_f) - \mathbb{P}(\tilde{F}_e)\mathbb{P}(\tilde{F}_f) \leq \mathbb{P}(\tilde{F}_e) \leq N^{-1/7+\delta}$$

for N large enough (we use the 2-arm exponent in the box $S(x_e, N^{4/7-2\delta})$). We deduce from it

$$\text{Var}[T_N] \leq \sum_e [6(2N^{4/7+\delta} + 1)^2 \times N^{-1/7+\delta}] + \epsilon_N$$

and finally

$$\begin{aligned} \text{Var}[T_N] &\leq [6(2N^{4/7+\delta} + 1)(\ell_N + 1)] \times [6(2N^{4/7+\delta} + 1)^2 N^{-1/7+\delta}] + \epsilon_N \\ &\ll N^{11/7+5\delta} \ell_N \end{aligned}$$

□

Remark 15. *Recall that for ordinary percolation, it is still an open problem to show that the typical length of an interface is comparable to its expected length. Here, things are easier because localization of the front implies a faster decorrelation.*

5 Outer boundary

In a similar way, we can also compute the length U_N of the outer boundary of \mathcal{F}_N . We now have to count the number of 3-arm points. There is no extra difficulty to adapt Kesten's result : being pivotal still leads to 4 arms locally, and the summation can be conducted identically.

Proposition 16. *For all $\delta > 0$, we have for N sufficiently large:*

$$N^{4/21-\delta} \ell_N \leq \mathbb{E}[U_N] \leq N^{4/21+\delta} \ell_N \quad (33)$$

The upper bound can be treated in the same way, but for the lower bound, we have to be a little more careful : we have to ensure that we can extend the two arms of the same type "disjointly". It can be done by using the fact that we can impose an occupied crossing in a $N^{4/7+\epsilon} \times N^{4/7+\epsilon}$ rhombus to arrive in a "corner" of size $N^{4/7-\epsilon}$ with probability at least $N^{-k\epsilon}$ for some constant k (for instance applying the RSW result $\log N^{2\epsilon}$ times).

The decorrelation arguments that we used for the length of the front can also be applied to the outer boundary, entailing convergence in L^2 if ℓ_N is not too small.

Proposition 17. *For each $\delta > 0$, we have for N sufficiently large:*

$$\text{Var}[U_N] \leq N^{4/3+\delta} \ell_N \quad (34)$$

Hence, if for some $\delta > 0$, $\ell_N \geq N^{20/21+\delta}$, then

$$\frac{U_N}{\mathbb{E}[U_N]} \longrightarrow 1 \quad \text{in } L^2, \text{ when } N \rightarrow \infty \quad (35)$$

Note that when $\ell_N = N$, then this result implies that U_N is of the order of $N^{25/21}$ with high probability.

6 Open questions

We have used here the logarithmic equivalence of Proposition 1, that has been proved in [27]. It is in fact conjectured that this equivalence holds up to multiplicative constants. For instance, the stronger assumption $\mathbb{P}_{1/2}(A_n^4) \asymp n^{-5/4}$ would lead to $L(p) \asymp |p - 1/2|^{-4/3}$, which would make it possible to derive a sharper description of the front (in most constructions, only one application of the *RSW* theorem would be sufficient).

One of the major issues would be to describe (if it exists) the scaling limit of the front, once properly renormalized. We could first argue as follows : in each of the sub-strips $[\pm N^{4/7-\delta}]$, everything “looks like criticality”, so the front will look the same as the border of a cluster in critical percolation, *i.e.* a SLE_6 .

The problem here is that we do not know how the front “bounces”, that is to say what happens when we are at a distance approximately $N^{4/7}$ of the critical line. In fact, the front could be linked to the kind of objects F. Camia, L. Fontes and C. Newman have recently constructed for percolation near criticality, of parameter $p = 1/2 + \lambda\delta^{3/4}$, λ being (possibly) inhomogeneous.

Acknowledgements

The author would like to thank warmly his supervisor W. Werner for suggesting this problem to him and his guidance. He also thanks J. van den Berg and F. Camia for useful discussions.

References

- [1] M. Aizenman, B. Duplantier, A. Aharony, Path crossing exponents and the external perimeter in 2D percolation, *Phys. Rev. Lett.* **83**, 1359-1362 (1999).

- [2] V. Beffara, V. Sidoravicius, Percolation theory, to appear in Encyclopedia of Mathematical Physics, Elsevier (2006).
- [3] J. Van den Berg, H. Kesten, Inequalities with applications to percolation and reliability, *J. Appl. Probab.* **22**, 556-569 (1985).
- [4] C. Borgs, J.T. Chayes, H. Kesten, J. Spencer, Uniform boundedness of critical crossing probabilities implies hyperscaling, *Rand. Struc. Alg.* **15**, 368-413 (1999).
- [5] C. Borgs, J.T. Chayes, H. Kesten, J. Spencer, The birth of the infinite cluster : finite-size scaling in percolation, *Comm. Math. Phys.* **224**, 153-204 (2001).
- [6] F. Camia, C.M. Newman, The full scaling limit of two-dimensional critical percolation, preprint, math.PR/0504036 (2005).
- [7] J.T. Chayes, L. Chayes, J. Fröhlich, The low-temperature behavior of disordered magnets, *Comm. Math. Phys.* **100**, 399-437 (1985).
- [8] J.T. Chayes, L. Chayes, D. Fisher, T. Spencer, Finite-size scaling and correlation lengths for disordered systems, *Phys. Rev. Lett.* **57**, 2999-3002 (1986).
- [9] J.T. Chayes, L. Chayes, On the upper critical dimension in Bernoulli percolation, *Comm. Math. Phys.* **113**, 27-48 (1987).
- [10] J.T. Chayes, L. Chayes, G.R. Grimmett, H. Kesten, R.H. Schonmann, The correlation length for the high-density phase of Bernoulli percolation, *Ann. Probab.* **17**, 1277-1302 (1989).
- [11] G.R. Grimmett, Percolation, 2nd edition, Springer, New York (1999).
- [12] H. Kesten, The critical probability of bond percolation on the square lattice equals $1/2$, *Comm. Math. Phys.* **74**, 41-59 (1980).
- [13] H. Kesten, Percolation theory for mathematicians, Birkhäuser, Boston (1982).
- [14] H. Kesten, The incipient infinite cluster in two-dimensional percolation, *Probab. Th. Rel. Fields* **73**, 369-394 (1986).
- [15] H. Kesten, A scaling relation at criticality for 2D-percolation, in Percolation theory and ergodic theory of infinite particle systems, IMA Volumes in Mathematics and its Applications **8**, 203-212 (1987).

- [16] H. Kesten, Scaling relations for 2D-percolation, *Comm. Math. Phys.* **109**, 109-156 (1987).
- [17] G.F. Lawler, O. Schramm, W. Werner, Values of Brownian intersection exponents I : Half-plane exponents, *Acta Mathematica* **187**, 237-273 (2001).
- [18] G.F. Lawler, O. Schramm, W. Werner, Values of Brownian intersection exponents II : Plane exponents, *Acta Mathematica* **187**, 275-308 (2001).
- [19] G.F. Lawler, O. Schramm, W. Werner, Values of Brownian intersection exponents III : Two-sided exponents, *Ann. Inst. H. Poincaré* **38**, 109-123 (2002).
- [20] G.F. Lawler, O. Schramm, W. Werner, One-arm exponent for critical 2D percolation, *Elec. J. Probab.* **7**, paper no.2 (2002).
- [21] B. Sapoval, M. Rosso, J.F. Gouyet, The fractal nature of a diffusion front and the relation to percolation, *J. Phys. Lett.* **46**, 146-156 (1985).
- [22] A. Desolneux, B. Sapoval, A. Baldassarri, Self-organized percolation power laws with and without fractal geometry in the etching of random solids, in *Fractal Geometry and Applications : A Jubilee of Benoit Mandelbrot*, *Proc. Symp. Pure Math.* **72** Part 2, 485-505 (2004).
- [23] M. Rosso, J.F. Gouyet, B. Sapoval, Determination of percolation probability from the use of a concentration gradient, *Phys. Rev. B* **32**, 6053-6054 (1985).
- [24] R.M. Ziff, B. Sapoval, The efficient determination of the percolation threshold by a frontier-generating walk in a gradient, *J. Phys. A Math. Gen.* **19**, 1169-1172 (1986).
- [25] O. Schramm, Scaling limits of loop-erased random walks and uniform spanning trees, *Israel J. Math.* **118**, 221-288 (2000).
- [26] S. Smirnov, Critical percolation in the plane : conformal invariance, Cardy's formula, scaling limits, *C. R. Acad. Sci. Paris Sér. I Math.* **333**, 239-244 (2001).
- [27] S. Smirnov, W. Werner, Critical exponents for two-dimensional percolation, *Math. Res. Lett.* **8**, 729-744 (2001).