



HAL
open science

Modeling and Monitoring of Hybrid Dynamic Systems with Feed-Forward Neural Networks: application to two tanks hydraulic system

Nadhir Messai, Philippe Thomas, Dimitri Lefebvre, Bernard Riera, Abdellah
Elmoudni

► **To cite this version:**

Nadhir Messai, Philippe Thomas, Dimitri Lefebvre, Bernard Riera, Abdellah Elmoudni. Modeling and Monitoring of Hybrid Dynamic Systems with Feed-Forward Neural Networks: application to two tanks hydraulic system. Workshop on Advanced Control and Diagnosis, Nov 2005, Mulhouse, France. pp.103-109. hal-00103137

HAL Id: hal-00103137

<https://hal.science/hal-00103137>

Submitted on 3 Oct 2006

HAL is a multi-disciplinary open access archive for the deposit and dissemination of scientific research documents, whether they are published or not. The documents may come from teaching and research institutions in France or abroad, or from public or private research centers.

L'archive ouverte pluridisciplinaire **HAL**, est destinée au dépôt et à la diffusion de documents scientifiques de niveau recherche, publiés ou non, émanant des établissements d'enseignement et de recherche français ou étrangers, des laboratoires publics ou privés.

Modeling and Monitoring of Hybrid Dynamic Systems with Feed-Forward Neural Networks: application to two tanks hydraulic system

N. Messai¹, P. Thomas², D. Lefebvre³, B. Riera¹ and A. Elmoudni⁴

Abstract: Within the model based diagnosis community, Fault Detection and Isolation (FDI) techniques for hybrid systems require the ability to discern between all the modes and to identify at each time the current mode. Unfortunately, these necessary conditions are very restrictive because, on one hand, only few partial results have been reported on the notion of discernability between the modes and, on the other hand, all the switching sequences must be systematically investigated. To overcome these drawbacks, this paper proposes to use Feed-forward Neural Networks in order to build average models of Hybrid System. This alternative can be particularly interesting either when we can not describe all the system's modes by Ordinary Differential Equations (ODEs) or when we can not investigate all the switching sequences. Once the Neural Networks models are obtained they are used to generate residuals and to achieve FDI without any need to discern or to estimate the current mode.

Index Terms: Fault detection, Neural Network, Hybrid Dynamic Systems, Identification

I. INTRODUCTION

Over the past years, the study of dynamic systems has focused on continuous-time systems and Discrete Event Systems (DES). Interest has emerged lately in Hybrid Dynamic Systems (HDS), which combines continuous and DES dynamics [5,31].

Generally, Hybrid Dynamic Systems can be represented by a sequence of continuous behaviours, which represent the modes of the system. Therefore, when a discrete event occurs it causes a switching from the current mode to another one as well as a jump in the values of the state variables and/or a change of the state dimensions [31].

Recently, many efforts are being spent on the synthesis of control laws that improve the performances and guarantee the stability of HDS. However, when faults occur these control laws become inefficient and Fault Detection and Isolation (FDI) techniques [11, 26] must be implemented to safeguard the

specified performances and to avoid the eventual shutdown or damage. In this context, the existing works show that, FDI techniques for hybrid systems require at first the ability to identify, at each time, the current mode [14]. Once the former is identified, a continuous state estimator, such as Kalman filter, could be used to track the continuous state [11]. Unfortunately, the identification of the current mode is a very hard task that implicates that all the modes are known and discernible and that involves the investigation of all the switching sequences.

To overcome these drawbacks, this paper proposes to use Feed-forward Neural Networks (NN) in order to build average models of the considered Hybrid Dynamic Systems. Such models will track all the modes of the HDS, without any need to identify the current one or to discern between them. Either there is non need to investigate systematically all the switching sequences, which can be very time consuming. Finally, it permits to decrease the detection time of the faults because the residuals are generated in using just some NNs instead of all the modes of the HDS.

The remainder of this paper is organized as follows. Section 2 presents briefly the modeling approaches of HDS as well as the proposed NN modeling approach. The existing FDI approaches for HDS and a classification of the faults that may be occurred are presented in section 3. The modeling and monitoring results of an academic example are presented in section 4 in order to show the performances and the drawbacks of the proposed approach. A summary and some future works conclude the paper.

II. MODELLING OF HYBRID SYSTEMS

A. Overview of Hybrid System models

A HDS is defined as [5]: $\langle Q, X, Y, F, G, \sigma_s, \sigma_c \rangle$

Where

$Q = \{q_i : i \in M, M = \{1, \dots, m\}\}$ is the set of discrete states, where M represents the possible modes of the system and m is the number of reachable modes.

$X = \bigcup_{i \in M} X_i, X_i \subseteq \mathfrak{R}^n$ is the state space of continues variables, where X_i is the state-subspace of mode i and $x_i(t) \in X_i$ is the continues state vector at time t .

$Y = \bigcup_{i \in M} Y_i, Y_i \subseteq \mathfrak{R}^k$ is the output space, where Y_i denotes the

¹ with Laboratoire CReSTIC-LAM, Université de Reims Champagne-Ardenne, Moulin de la Housse BP 1039, 51687 REIMS cedex 2 France (e-mail : {nadir.messai; bernard.riera}@univ-reims.fr)

² with CRAN, ENSTIB 27 rue du merle blanc, B.P. 1041, 88051 Epinal cedex 9 (e-mail : philippe.thomas@cran.uhp-nancy.fr)

³ with GREAH - Université Le Havre -76063 - Le Havre - France (e-mail : dimitri.lefebvre@univ-lehavre.fr)

⁴ with Laboratoire SeT, Université de Technologie de Belfort-Montbéliard, 90010 Belfort Cedex France (e-mail : abdellah.elmoudni@utbm.fr)

subspace associated with mode i and $y_i(t) \in Y_i$ is the measured output vector at time t .

$F = \{f_1, f_2, \dots, f_m\}$ is a finite set of functions such that each function $f_i, i \in M$ defines the trajectory of the state vector $x_i(t) \in X_i$.

$G = \{g_1, g_2, \dots, g_m\}$ is a finite set of functions such that each function $g_i, i \in M$ defines the output vector of the mode i .

$\sigma_s = \{\sigma_s^{ij}\}: Q \times X \rightarrow Q \times X$ is an application that defines a spontaneous switching from the mode i to the mode j .

$\sigma_c = \{\sigma_c^{ij}\}: Q \times E \rightarrow Q \times X$ is an application that defines a forced switching from the mode i to the mode j .

One natural approach to model HDS [5] is to extend the existing models of continuous systems by adding discrete switching. Hence, the early attempt to provide a formal framework for the modelling of hybrid phenomena is the differential automata which represent the continuous trajectories by ODEs and consider the discrete part as piecewise constants [27]. This model was generalized by introducing jumps of the state, abrupt changes as well as control inputs [4].

Alternative descriptions of Hybrid systems can be derived from discrete models. Typical models of this class are automata [23] and Petri Nets [22]. Unfortunately, PN and automata have the inconvenience to refer to time only by ordering the events. Hence, these models were extended by the addition of timers that define the durations of the continuous behaviours: timed PN [34] as well as timed automata has been defined [1]. In timed PN the time is taken into account by means of duration associated either with places or with transitions [24] and in timed automata a set of clocks running at the same rate is added [1].

Hybrid automata can be viewed as a generalization of timed automata. This model includes continuous dynamics and discrete transitions which may depend on the evolution of the continuous behaviours. In a hybrid automaton a switched continuous system is unfolded into different discrete locations that correspond to the possible discrete modes. As for timed automata, the conditions for transitions of the discrete state can be expressed by logical conditions and events attached to the arcs or by invariants. Unfortunately, writing the set of all differential equations of a real-world hybrid system is very time consuming. As a consequence, hybrid automata are not very well appropriate to model complex systems. Finally, Hybrid Petri Nets (HPNs) are a tool which can treat integer variables simultaneously with real and symbolic variables [16]. They have the advantage to combine intuitive graphical representation and powerful analytic expressions. However, they present the same drawback as hybrid automata.

B. Description of the NN modelling approach

A possible alternative approach, that permits to overcome some drawbacks of the existing HDS models, consists to consider the plan as a black-box model and try to capture globally its behaviour's. This solution can be particularly

interesting either when we can not write all the ODEs or when we have not any physical knowledge about the parameters of the models. It can also be used in a modular way and combined with physical models, when it is possible to decompose the global system into several smaller parts.

In the next sections, we will consider feed-forward neural networks (NN) as global parametric models of HDS. Our choice is motivated by the fact that feed-forward neural networks can extract powerful models from experimental data without having to carry out any assumptions on the general form of these models [7]. However, to the best of our knowledge, NNs are only used to approximate continuous systems and DES but they have never been used to approximate HDS.

Hence, this work intends to show that the behaviours of HDS can be predicated with feed-forward neural networks. This alternative is interesting for complex real world systems, which are generally equipped with sensors that can give us the experimental data.

In comparing with the existing works, this approach has the potential advantage to avoid the identification parameters of all the modes as well as the switching sequences. On the other hand, the proposed technique has the originality to combine continuous behaviours and discrete events in the same structure. In fact, at each step time KT , the measured output vector $y_i(KT) \in Y_i$ as well as σ_s and σ_c are presented to the NNs, which will predicate the continuous outputs at the next step time (i.e., the spontaneous and the forced switching are supposed observable and they are equal to 1 when the discrete event happen). Finally, let us note that these global models are very useful for the control of some HDS, particularly those which exhibit periodical behaviours [3].

In this context, the modelling problem of HDS by NNs will be solved by selecting the optimal NN structure and by choosing the regressors vector (i.e., the inputs of the NN).

To deal with the first problem, different approaches that find automatically the appropriate network architecture have been proposed. One consists in training an oversized network and removing the parts that are not needed. The methods using this approach are called pruning algorithms [25]. The other approach, which corresponds to constructive algorithms, attempts to start with a small network and then add hidden units until a satisfactory solution is found [15].

Concerning the selection of regressors, the balance of discussions recommends to start with the NNARX structure given by [19]:

$$\hat{y}(k/\theta) = f[y(k-1), \dots, y(k-n_a), U(k-n_b), \dots, U(k-n_b-n_k+1)] \quad (1)$$

where:

θ is the parameters vector,

$\hat{y}(k)$ and $y(k)$ are respectively the estimated and the real outputs of the system at time kT ,

$U(k)$ are the inputs of the system at time kT ,

n_a , n_b and n_k are respectively the orders of the system and the delay.

Since one starts with the preceding structure, the construction of the best model becomes a problem of estimating both the orders n_a , n_b and the delay n_k . A methodology that permits the estimation of the delay consists to [19]:

- Choose a sufficiently high identical values for n_a and n_b ,
- Estimate the parameters of the model for various values of n_k ,
- Select the model corresponding to both the minimum of the sum quadratic error and the bests cross correlation functions.

Once the delays are fixed, the model orders are determined by analyzing the auto correlation functions and studying both the sum quadratic error (SQE) and the final prediction error (FPE) for various combinations of n_a , n_b .

Let us note that the obtained NNs do not estimate all the modes of the HDS but the average continuous outputs. Furthermore, the parameters of these NN depend on the sequence of excitation (σ_s and σ_c) and consequently on the sequence of discrete states visited by the system. Hence, in order to obtain NNs, which can be considered as global models of the HDS, it is necessary to use data sets that represent all switching between the modes.

III. DIAGNOSIS OF HYBRID SYSTEMS

Several model based methods [11] approaches have been investigated for faults detection and isolation of HDS. According to the modelling point of view, these approaches can be divided into two classes that correspond to continuous time model and discrete event ones.

In [13], a local linearization has been proposed in order to apply continuous methods like residual generation. Similarly, local linearization has also been investigated in [10] before using the parity space approach. The main drawback of such methods is the small size of the domain of validity. In fact, these methods are local ones. As a consequence, they are applied only in a single mode and the residual synthesis and analysis must be computed again when the system commutes from one mode to another. The projection of residuals in parity space can be used in order to study the discernability between faults and operating modes [6]. Similar results have been obtained by using observers with finite memory [14]. The main drawback of such methods is that they result in NP complexity because the diagnoser must build, at each time, all admissible trajectories in order to discern a possible fault occurrence from a mode commutation. The Mixed Logical Dynamic approach (MLD) has been also investigated in order to improve the diagnosis of HDS [28]. Some results obtained for identification of piecewise affine systems could be adapted in order to provide on line parameter estimation and fault detection [9]. For such methods, a huge difficulty remains: cluster the data that result from a mode switching and the ones that result from the occurrence of a fault.

Based on discrete event models and PN theory, the faulty behaviours have been modelled either as forbidden states [12]

or as forbidden event sequences [18]. Both approaches can be used in the context of diagnosis under partial observation. Fault diagnosis under state measurement and events estimation was first formulated with automata [26] and then extended to PN [29]. The considered PN are live and safe. A label is associated to each transition in order to distinguish “normal” behaviour from faulty ones. Starting from an initial normal state, the system may evolve according to a “normal” behaviour by firing “normal” transitions or according to a faulty behaviour by firing at least one “fault” transition. The diagnoser detects and isolates a failure transition in a given firing sequence from measurement of the successive observable markings generated by the system. Faults diagnosis under events measurement and state estimation was also considered with automata [30] and Petri nets [17]. The PN state estimation consists to estimate the PN marking based on complete or partial observation of the events. If the initial marking is known, some projections of the incidence matrix over the set of transitions to be measured and the set of markings to be estimated can be used [17]. When the initial marking is unknown [12], state estimators have been proposed that provide a lower bound of the actual marking. Asynchronous diagnosis by means of hidden state history reconstruction obtained from alarm observations was also investigated [2]. This approach relies on Petri net unfoldings and event structures that are related via some causality relationships. As a consequence, diagnosis is performed by a distributed architecture of supervisors.

At last, let us mention some works that have investigated hybrid approaches for diagnosis with continuous observers and output quantification [20], [21].

In comparing with the existing works, the proposed approach can be considered as a hybrid one because the NNs used to model the various modes of the HDS combine continuous behaviour and discrete events. This approach has the advantage to possess a large domain of validity because the NNs will predicate all the modes of the HDS. In addition, it is not difficult to implement because there is any need to differentiate a possible fault occurrence from a mode commutation. However, its huge difficulty remains the obtaining of data sets that cover all the modes of the HDS.

IV. APPLICATION EXAMPLE

In order to illustrate and to show the effectiveness of the proposed approach let us consider the two tanks flow system of the figure 1. This system is the benchmark of the Specific Action on the diagnosis of hybrid systems (AS193) which is supported by the CNRS⁴ and the GDR MACS⁵.

A. Description of the system

The system consists of two cylindrical tanks R_1 and R_2 of section $S = 0.0154$. Each tank has an input pipe and an output pipe. The input pipes are respectively built-in identical pumps

⁴ Centre National de la Recherche Scientifique

⁵ Groupe de Recherche "Modélisation, Analyse et Conduite des Systèmes dynamiques"

P_1 and P_2 that are on-off and the output pipes are controlled by two on-off electro valves V_1 and V_2 . Moreover, the tanks are connected to each other with two pipes, C_1 and C_2 , which are respectively located at the bottom of the tanks and at $0.5 m$ height. These pipes are also controlled by the on-off electro valves V_3 and V_4 . Finally, the system is equipped with two analogue sensors that measure the levels of the fluid in the tanks.

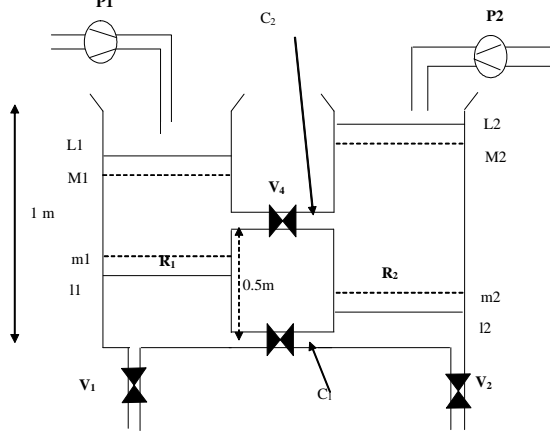

Figure 1: the two tanks system

For the purpose of simulation let us consider that the dynamics of the pumps are very fast. Hence, we can suppose that the input flows are constants when the pumps are on and they are null when the pumps are off. Finally, let us suppose that the pump P_1 and the electro valve V_2 are a perturbation inputs that can not be controlled.

According to the Torricelli model, the considered system can be described by the following equations:

$$Q_{P1} = D.P_1, \quad P_1 \in \{0,1\} \quad (2)$$

$$Q_{P2} = D.P_2, \quad P_2 \in \{0,1\} \quad (3)$$

$$Q_1 = A\sqrt{2.g.h_1}V_1, \quad V_1 \in \{0,1\} \quad (4)$$

$$Q_2 = A\sqrt{2.g.h_2}V_2, \quad V_2 \in \{0,1\} \quad (5)$$

$$Q_3 = A\sqrt{2.g \text{ sign}(h_1 - h_2)} \cdot \sqrt{|h_1 - h_2|}V_3, \quad V_3 \in \{0,1\} \quad (6)$$

$$Q_4 = A\sqrt{2.g \cdot \text{sgn}(h_1 - h_2)} \cdot \sqrt{|\text{sup}(h_1, 0.5) - \text{sup}(h_2, 0.5)|}V_4, \quad V_4 \in \{0,1\} \quad (7)$$

where: D is the constant input flow of both the pumps ($D=10^{-4} m^3/Sec$), $Q_{P_i, i \in \{1,2\}}$ is the input flow of the tank i , $Q_{i, i \in \{1,2\}}$ is the output flow of the tank i , Q_3 is the flow in the pipe C_1 and Q_4 is the flow in the pipe C_2 .

Concerning the control laws, let us consider that the electro valves V_1 , V_3 and V_4 as well as the pump P_1 are governed according to the algorithm depicted in the table 1 [12]. This algorithm, which does not make the objective of this paper, guarantee that the levels of the fluids in the tanks R_1 and R_2 are respectively given by the equations:

$$m_1 \leq h_1 \leq M_1 \quad (8)$$

$$m_2 \leq h_2 \leq M_2 \quad (9)$$

where : $M_1 = 0.6 m$; $M_2 = 0.75 m$; $m_1 = 0.4 m$ and $m_2 = 0.2 m$

are thresholds that are chosen in order to avoid either the draining or the overflow of the tanks.

	$h_1 \geq M_1$	$M_1 > h_1 > m_1$	$m_1 \geq h_1$
$h_2(k-1) \geq M_2$	$P_1(k)=0$ $V_1(k)=1$ $V_3(k)=1$ $V_4(k)=1$	$P_1(k)=P_1(k-1)$ $V_1(k)=V_1(k-1)$ $V_3(k)=1$ $V_4(k)=1$	$P_1(k)=0$ $V_1(k)=0$ $V_3(k)=1$ $V_4(k)=1$
$M_2 > h_2(k-1) > m_2$	$P_1(k)=1$ $V_1(k)=V_1(k-1)$ $V_3(k)=0$ $V_4(k)=0$	$P_1(k)=P_1(k-1)$ $V_1(k)=V_1(k-1)$ $V_3(k)=V_3(k-1)$ $V_4(k)=V_4(k-1)$	$P_1(k)=P_1(k-1)$ $V_1(k)=1$ $V_3(k)=1$ $V_4(k)=1$
$m_2 \geq h_2(k-1)$	$P_1(k)=0$ $V_1(k)=0$ $V_3(k)=1$ $V_4(k)=1$	$P_1(k)=P_1(k-1)$ $V_1(k)=V_1(k-1)$ $V_3(k)=1$ $V_4(k)=1$	$P_1(k)=1$ $V_1(k)=0$ $V_3(k)=1$ $V_4(k)=1$

Table 1: The control Algorithm

B. The NN modeling results

The precedent system, which can have as well as 44 modes, has been modelled by two feed-forward neural networks according to the methodology presented in section 2. Each NN corresponds to the nonlinear NNARX structure given by the equation 1 and it predicts the level of the liquid in a tank.

In order to obtain the structures of the two black-box average models, the identification and the validation of the NNs were carried out, with two different data sets containing each one $N = 5000$. The latter were obtained by simulating the behaviours of the system, in using equations 2 to 7 and by considering that the sampling period is $\Delta t = 1s$ and by considering that the initial condition of the identification and the validation data set are respectively $h_0 = h_1 = 0$ and $h_0 = h_1 = 1$. Finally, Gaussian noises of mean $m=0$ and variance $\sigma = 1\%$. $h_{\max} = 0.01$ were added to the data sets.

Hence, after several simulations, carried out by fixing n_a and n_b to 5 delays and varying n_k from 1 to 5, we have opted for two NNs with:

- 21 input neurons that receive the last three outputs of the sensors as well as last three state of the valves,
- 8 hidden neurons that calculate the weighted sum of their inputs, then transform it by means of a hyperbolic tangent activation functions,
- 1 outputs neuron using a linear activation function. this out permit to predicate the level of the liquid in the considered tank.

P_2 and V_2 were opened and closed according to two SBPA of length: $l_{p2} \in [10,30]$ and $l_{v2} \in [30,50]$

On the other hand, the network's parameters were estimated with 20 different initializations and 5000 iterations at the maximum, by means of Levenberg-Marquardt algorithm. Then, starting from a structure using ($n_e = n_a + 2n_b$) inputs and 7 hidden neurons, the Optimal Brain Surgeon (OBS) algorithm was used to remove the parts that are not needed.

The figures (1-a), (1-b), (1-c), (2-a), (2-b) and (2-c) present, respectively, the identification and the validation results of the selected models. The analysis of these curves shows that the predicted levels closely matches the data and indicates that the sum quadratic errors correspond to the added noise. On the other hand, the statistical tests express that the residuals and the

inputs are independent and that the auto correlation functions belong to the confidence interval. In addition, the histograms of the residues distributions indicate that the errors of modelling, in the absence of faults, can be regarded as a white noise.

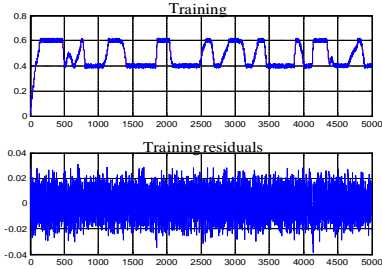

Figure 1-a: training results of the liquid level in R_1

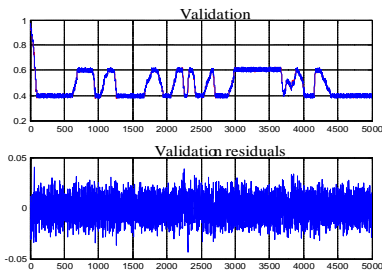

Figure 1-b: validation results of the liquid level in R_1

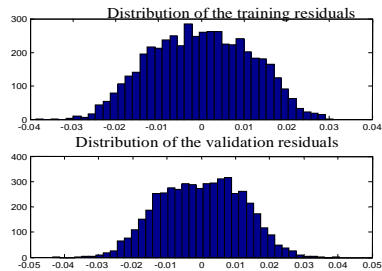

Figure 1-c: distribution of the residues for the 1st NN

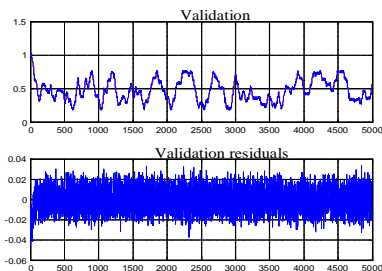

Figure 2-a: training results of the liquid level in R_2

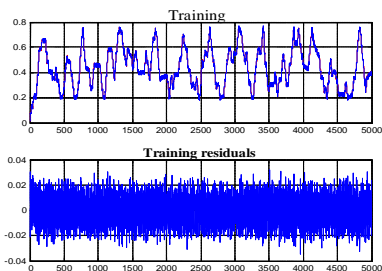

Figure 2-b: validation results of the liquid level in R_2

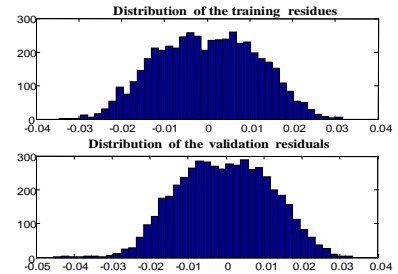

Figure 2-c: distribution of the residues for the 2nd NN

C. The NN model-based fault detection results

In this section we will consider simple fault that can affect either the sensor or the actuator

1) Detection of the sensor faults

During this simulation let us consider that the two sensors provide biased values and that initial conditions are: $h_0 = h_1 = 0.5$. Thus, the NNs obtained in the previous section were used in order to simulate the system behavior. The residuals, resulting from the comparison of the two sensors outputs with the predictions of the two NN, are then exploited in order to detect the simulated faults. Finally, let us note that the biases were injected in different mode of the HDS and that the faults of the 1st sensor are detected by using the NN that predicate h_1 (NN_1) and the faults of the 2nd sensor are detected by using the NN that predicate h_2 (NN_2).

Tables 2 and 3 summarize the results concerning the detection of the injected faults. The letters correspond to biases with amplitude which varies from 0.5σ to 3σ . The analysis of these results which correspond to a probability of false alarm $P=1\%$, indicates that detection is independent of the moment of occurrence of the faults and that the detection time varies between 1sec and 3sec.

		Amplitude of the bias			
		0.5σ	0.8σ	1.5σ	3σ
Instant of the default	1000	ND	1sec	1sec	2sec
	2000	3sec	2sec	2sec	2sec
	3000	2sec	2sec	2sec	2sec

Table 2: Detection of the 1st sensor faults

		Amplitude of the bias			
		0.5σ	0.8σ	1.5σ	3σ
Instant of the default	1000	2sec	2sec	1sec	1sec
	2000	ND	1sec	1sec	1sec
	3000	1sec	1sec	2sec	2sec

Table 3: Detection of the 2nd sensor faults

2) Detection of the actuator faults

During this simulation let us consider that one of the actuators (P_1, V_1, V_3, V_4) is blocked opened or closed either from the instant $t_1 = 300$ sec or from the instant $t_2 = 500$ sec (i.e., the defaults affect two different modes).

Tables 4 to 7 present the detection results obtained in using both the NN and by considering a probability of false alarm $P=1\%$. The analysis of these results indicates that the defaults of P_1 were detected only by the NN_1 and that the defaults of V_3 were detected by the two models jointly.

We can also note that the detection times are relatively high and that they depend on the current mode of the system at the

moment of the occurrence of the default. Finally, it is difficult to conclude definitively on the detection of the fault concerning V_1 and V_4 because of the weak results obtained in tables 5 and 7.

NN	$P_1=0$		$P_1=1$	
	$t_1=300\text{sec}$	$t_2=500\text{sec}$	$t_1=300\text{sec}$	$t_2=500\text{sec}$
NN ₁	85sec	100sec	20sec	97sec
NN ₂	ND	ND	ND	ND

Table 4: Detection of the fault of P_1

NN	$V_1=0$		$V_1=1$	
	$t_1=300\text{sec}$	$t_2=500\text{sec}$	$t_1=300\text{sec}$	$t_2=500\text{sec}$
NN ₁	FD	FD	FD	FD
NN ₂	FD	71sec	FD	71sec

Table 5: Detection of the fault of V_1

NN	$V_3=0$		$V_3=1$	
	$t_1=300\text{sec}$	$t_2=500\text{sec}$	$t_1=300\text{sec}$	$t_2=500\text{sec}$
NN ₁	164sec	44sec	164sec	44sec
NN ₂	376sec	249sec	376sec	249sec

Table 6: Detection of the fault of V_3

NN	$V_4=0$		$V_4=1$	
	$t_1=300\text{sec}$	$t_2=500\text{sec}$	$t_1=300\text{sec}$	$t_2=500\text{sec}$
NN ₁	59sec	FD	59sec	FD
NN ₂	FD	69sec	FD	69sec

Table 7: Detection of the fault of V_4

Consequently, the FDI indicate that only two defaults can be isolated (i.e., defaults of V_3 which are detected by the two NN and the defaults of the 2nd sensor which are detected by NN₂). Moreover, the defaults of the 1st sensor and the default of the actuator P_1 can be detected without a possibility of isolation (both of them are detected by NN₁).

V. CONCLUSIONS

Our contributions were to build average models of HDS and to show that these models can be used for the Diagnosis of HDS. The behaviors of HDS were predicted by feed-forward neural networks that track all the modes of the system and the structure determination of these neural networks was viewed as a system identification problem. The performances of this approach were shown on a simulation example and the obtained results provide strong evidence of the good performance the NN average model. Once the Neural Networks models are obtained they have been used to generate residuals and to achieve FD without any need to discern the modes, to estimate the current mode or to investigate systematically all the switching sequences. The application example results shows that the proposed approach is very useful to detect sensors faults but it is not enough well for the detection of the actuators faults. Our future works are to exploit other information as the occurrence of the alarms and the causalities in order to improve the performances of the diagnosis results.

VI. REFERENCES

- [1] Alur R., Dill D., 1994, The theory of timed automata, Theoretical and computer science, vol. 126, pp. 183-235,
- [2] Benveniste A., Fabre F., Jard C., Haar S., 2003, Diagnosis of asynchronous discrete event systems, a net unfolding approach. IEEE-TAC, vol. 48, no.5.
- [3] Bogolubov N., Mitropolski N., Yu A., 1961, Asymptotic methods in the theory of non-linear oscillations, Gordon & Breach, New York.
- [4] Branicky M, Borkar V., Mitter S., 1994, Unified framework for hybrid control A., IEEE Conf. On Decision and Control, pp. 4228-4234.
- [5] Branicky M., 1996, General hybrid dynamic system modeling: analysis and control. Lecture note. Hybrid System III, 4066, pp. 187-200.
- [6] Cocquemont V., El Mezayani T., Staroswiecki M., 2004, Fault Detection and Isolation for Hybrid Systems using Structured Parity Residuals, *ASCC'2004 : Asian Control Conference*, Melbourne, Australie.
- [7] Cybenko G., 1989, Approximation by superposition of sigmoidale function, *Mathematics of Control Signal and Systems*, vol. 2, pp. 524-532.
- [8] Delherm C., Druaux F., Leclercq E., Lefebvre D., Messai N., Thomas P., EL Moudni A., 2004, Diagnostic des systèmes dynamiques hybrides par réseaux de Petri et réseaux roaux, AS 193, 30 janvier 2004, Paris, France
- [9] Ferrari-Trecate G., Muselli M., Liberati D., Morari M., 2003, A clustering technique for the identification of piecewise affine systems, *Automatica*, vol., pp. 39, 205 – 217.
- [10] Frisk E., 2000, Residual generator design for non linear, polynomial systems: a Gröbner basis approach, In *Proc. IFAC Fault Detection, Supervision and Safety for Technical Processes*, Budapest, Hungary.
- [11] Gertler J., 1998, *Fault detection and diagnosis in Engineering systems*. Marcel Dekker, Inc., New York, USA.
- [12] Giua A., Seatzy C., 2002, Observability of place / transition nets, IEEE – TAC, vol. 47, no. 9, pp. 1424 – 1437.
- [13] Klein M., 2000, Nielsen L. Evaluating some Gain Scheduling Strategies in Diagnosis of a Tank, in *Proc. IFAC Fault Detection, Supervision and Safety for Technical Processes*, Budapest, Hungary.
- [14] Kratz F., Aubry D., 2003, Finite memory observer for state estimation of hybrid systems, *Proc. of IFAC Safeprocess'03*, Washington D.C.
- [15] Kwok T.Y., Yeung D.Y., 1997, Constructive algorithms for structure learning in feedforward neural networks for regression problems, *IEEE Transaction on NN*, Vol. 8, no 3., pp. 630-645.
- [16] Le Bail J., Alla H., 1991, David R., Hybrid Petri Nets, 1st European Control Conference, Grenoble, France, pp. 1472-1477.
- [17] Lefebvre D., 2004, About estimation problems with Petri net models for fault detection and isolation with discrete event and hybrid systems, SAUM 04, pp. 42 – 51, Beograd, Serbia and Montenegro.
- [18] Lefebvre D., El Moudni A., 2001, Firing and enabling sequences estimation for timed Petri nets, *IEEE / SMC part A*, vol. 31, no.3, pp 153-162.
- [19] Ljung L., 1987, *System identification: Theory for the user*, Prentice-Hall, Englewood Cliffs, N.J.
- [20] Lunze J., Schröder J. 2004, Sensor and Actuator Fault Diagnosis of Systems With Discrete Inputs and Outputs, *IEEE Transactions on Systems, Man, and Cybernetics*, part b, vol. 34, no. 2, .
- [21] Manders E.J., Narasimhan S., Biswas. G., Mosterman P.J., 2000, A combined qualitative/quantitative approach for efficient fault isolation in complex dynamic systems, In *Proc. 4th symposium on fault detection, supervision and safety processes*, pp. 512-517.
- [22] Murata T., 1989, Petri nets: properties, analysis, applications, *Proceedings of the IEEE*, vol., 77, pp. 541-580.
- [23] Nerode A., Kohn W., 1993, Models for hybrid systems,: Automata, topologies, controllability, observability, in: *Hybrid Systems, Lecture Note in Computer Science*, vol. 736, pp. 317-356.
- [24] Peterson J.L., 1981, *Petri Net theory and the modelling of systems*, London, Prentice Hall, .
- [25] Reed R., 1993, Pruning algorithms—a survey, *IEEE Transaction on NN*, Vol. 4, no 5., pp. 740-747
- [26] Sampath M., Sengupta R., Lafortune S., Sinnamohideen K., Teneketzis D., 1995, Diagnosibility of discrete event systems, IEEE-TAC, vol. 40, no.9, pp. 1555- 1575.
- [27] Tavernini L, 1987, Differential automata and their discret simulators, *Nonlinear Analysis, Theory, Methods and Applications*, vol. 11, pp. 665-683.
- [28] Tyler M. L., Morari M., 1999, Propositional logic in control and monitoring problems, *Automatica*, vol. 35, pp. 565–582.
- [29] Ushio T., Onishi I., Okuda K., 1998, Fault detection based on Petri net models with faulty behaviours, IEEE – SMC, pp 113-118.
- [30] Wang C., Schwartz M., 1993, Fault detection with multiple observers, IEEE/ACM, *Trans. On Networking*, vol. 1, no. 1, pp 48 – 55.
- [31] Zaytoon J., (editor), 1998, *Hybrid dynamical systems, APII - JESA*, vol 32, n° 9-10.