



**HAL**  
open science

## 1-kHz table-top ultrashort hard x-ray source for time-resolved x-ray protein

Adeline Bonvalet, Adeline Darmon, Jean-Christophe Lambry, Jean-Louis  
Martin, Patrick Audebert

► **To cite this version:**

Adeline Bonvalet, Adeline Darmon, Jean-Christophe Lambry, Jean-Louis Martin, Patrick Audebert.  
1-kHz table-top ultrashort hard x-ray source for time-resolved x-ray protein. *Optics Letters*, 2006, 31  
(18), pp.2753. 10.1364/OL.31.002753 . hal-00097211

**HAL Id: hal-00097211**

**<https://hal.science/hal-00097211>**

Submitted on 23 May 2014

**HAL** is a multi-disciplinary open access archive for the deposit and dissemination of scientific research documents, whether they are published or not. The documents may come from teaching and research institutions in France or abroad, or from public or private research centers.

L'archive ouverte pluridisciplinaire **HAL**, est destinée au dépôt et à la diffusion de documents scientifiques de niveau recherche, publiés ou non, émanant des établissements d'enseignement et de recherche français ou étrangers, des laboratoires publics ou privés.

# 1 kHz tabletop ultrashort hard x-ray source for time-resolved x-ray protein crystallography

Adeline Bonvalet, Adeline Darmon, Jean-Christophe Lambry, and Jean-Louis Martin

Laboratoire d'Optique et Biosciences CNRS UMR 7645–INSERM U696–Ecole Polytechnique,  
91 128 Palaiseau Cedex, France

Patrick Audebert

Laboratoire pour l'Utilisation des Lasers Intenses, UMR 7605 CNRS–CEA–Ecole Polytechnique–Université  
Pierre et Marie Curie, 91 128 Palaiseau Cedex, France

Received April 14, 2006; revised July 3, 2006; accepted July 4, 2006;  
posted July 10, 2006 (Doc. ID 69980); published August 25, 2006

We describe a compact, reliable, and high-average-power femtosecond x-ray source and its first application to diffraction on protein crystal. The setup relies on a homemade Ti:sapphire system delivering 12 mJ at a 1 kHz repetition rate, associated with a small vacuum chamber especially designed for laser-plasma interaction and x-ray applications. This device allows the generation of  $5 \times 10^9$  photons/s/sr at 8 keV and optimized x-ray irradiation of the studied sample, which can be placed close to the source. We present the diffraction pattern of a protein crystal in a divergent beam geometry, which is a first step to a subpicosecond x-ray diffraction experiment. © 2006 Optical Society of America  
OCIS codes: 320.5550, 320.7090, 340.7480, 350.5400.

The generation of ultrashort hard x-ray sources is of prime interest for a broad range of applications in biology, chemistry, and physics, since it should extend three-dimensional structure determination to the femtosecond time scale. In recent years, several experiments aimed to follow structural evolution in simple crystals by using the ultrashort x-ray pulses emitted by a laser-plasma source<sup>1–5</sup> or other techniques.<sup>6,7</sup> But the low flux of these sources makes diffraction experiments on more demanding diffractors such as protein crystals more difficult.<sup>8</sup> Therefore laser-plasma sources offer a great advantage over other x-ray sources, since they should allow temporal resolution down to the period of atomic vibration, typically of the order of 100 fs. To reach this objective, ultrashort x-ray sources must become compact and reliable and exhibit high average power. Moreover, their potential must be better utilized by developing a new diffraction method that takes advantage of laser-plasma source divergence.<sup>9</sup>

Ultrafast monochromatic x-ray pulses can be generated by the interaction of ultrashort laser pulses of adjusted intensity with condensed matter.<sup>10–13</sup> Recently, detailed experimental<sup>14–16</sup> and theoretical<sup>17</sup> studies have characterized the dependence of the emission over laser and target characteristics. Laser parameters such as pulse duration, focal intensity, polarization, incidence angle, and intensity contrast ratio play an important role in x-ray yield. Targets have to move fast enough to present a virgin surface at each laser shot while remaining precisely aligned. In addition, the concept of a robust high-repetition-rate laser-plasma source requires particular attention to the debris generated by the laser–target interaction.

In this Letter we describe an ultrashort hard x-ray source relying on a simple and unique 12 mJ, 1 kHz Ti:sapphire amplifier and present the diffraction pat-

tern of a protein crystal exposed to a divergent beam. The whole setup has been carefully designed to gather the key features for time-resolved crystallography, such as reliability, high average power, and optimized flux on the studied sample.

The experimental setup is shown in Fig. 1. The laser system delivers 12 mJ, 160 fs pulses at a 1 kHz repetition rate, with high spatial quality, a measured level of amplified spontaneous emission  $10^9$  lower than the main pulse, and contrast with intrinsic nanosecond and picosecond prepulses measured to be  $5 \times 10^6$  and  $5 \times 10^4$ , respectively. The system relies on a commercial oscillator and regenerative amplifier (Hurricane, Spectra-Physics), delivering 0.8 mJ and seeding a homemade amplifier pumped by three frequency-doubled diode-pumped Nd:YLF lasers (two Jades, Thales-Laser; one Evolution-30, Positive Light). To limit thermal lensing due to large pump fluence onto the amplifying crystal (Crystal Systems, 10 mm  $\times$  10 mm  $\times$  10 mm, 90% absorption at 527 nm), we have designed a simple liquid-nitrogen-

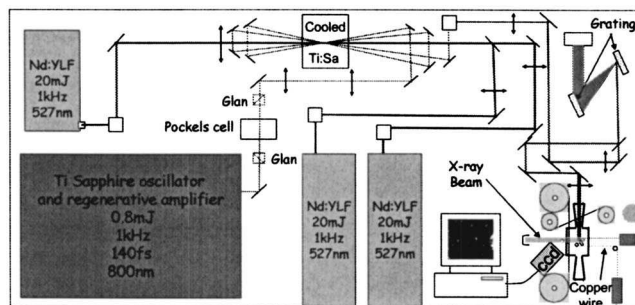

Fig. 1. Design of the experimental setup. The beams of the two 20 W Nd:YLF lasers are in two different quasi-horizontal planes. Two Glan–Laser polarizing prisms and a Pockels cell (Medox, Thales Laser) reduce the nanosecond prepulses issued from leakage in the regenerative amplifier.

cooled cryostat that yields a decrease in the focal-length power from  $f=49$  cm at 300 K to  $f=9.6$  m at 100 K while using 63 W of total pump power.<sup>18</sup> We obtained a very simple and compact 4-pass amplifier that routinely delivers 18 mJ with excellent spatial quality. Temporal compression of the pulses is achieved in a two-grating compressor (120 mm  $\times$  140 mm, groove density 2000 lines/mm), leading to pulses of 12 mJ energy and 160 fs duration.

The x-ray source consists of a copper wire running through a small vacuum chamber (see Fig. 2). The wire, issued from a spool, is first flattened and moved by a motorized rolling mill to expose a flat and fresh surface to each laser shot. It then crosses the chamber through two Teflon guides that maintain an air pressure of 100 Pa and is guided by two free-rotating bearings. The wire tension is controlled by a pair of toothed wheels that pulled the wire out from the chamber. The jitter of the wire motion is still reduced by a small metallic finger positioned between the bearings. The laser beam is focused with an 18 cm focal-length lens and hits the wire with an incidence angle of 60°. The laser intensity on the target is estimated to  $3 \times 10^{16}$  W/cm<sup>2</sup>, which is thought to be optimum for Cu-K $\alpha$  x-ray yield.<sup>17</sup> X-rays are collected through a 17 mm diameter beryllium window placed 16 mm from the target. The deposition of debris on the beryllium window is prevented by a 12.5 mm wide plastic band continuously moving in front of it (1 m/min). The laser beam entrance window is also protected by a similar running band system, with a slower speed (25 mm/h), and a band tilt that optimizes the laser beam transmission. The spectrum is measured by analyzing the deposited energy of individual x-ray photons on a thermoelectrically cooled CCD camera (Andor Technology, DY434-FI-962),<sup>19</sup> that was previously calibrated with an Fe<sup>55</sup> source emitting K $\alpha$  radiation at 5.9 keV. The emitted laser-plasma x-ray spectrum consists of a broad continuum and two narrow features at 8.05 and 8.91 keV corresponding to the characteristic K $\alpha$  and K $\beta$  lines of copper, respectively. If necessary, the K $\beta$  photons can be filtered with a thin Ni foil. The Cu K $\alpha$  yield was evaluated by considering the CCD efficiency at 8 keV (given by the manufacturer), and integration of the measured spectra over the K $\alpha$  line and is found to be  $5 \times 10^9$  photons/s/sr. The size of the x-ray emitting spot has been determined in the horizontal plane by using a knife-edge technique and is 20  $\mu$ m FWHM. It is larger than the laser spot (7  $\mu$ m FWHM), which may be due to either the jitter in the wire motion or the spreading of fast electrons in the target.

We performed an x-ray diffraction experiment on a protein crystal with a 1 kHz laser-plasma source. Conventional methods for single-crystal diffraction data collection are based on a collimated beam. However, collimating an x-ray beam greatly decreases the flux available on the sample, making diffraction on weak diffractors such as protein crystal difficult. Here we have applied a new method first demonstrated by Ho *et al.*,<sup>9</sup> in which a stationary crystal is

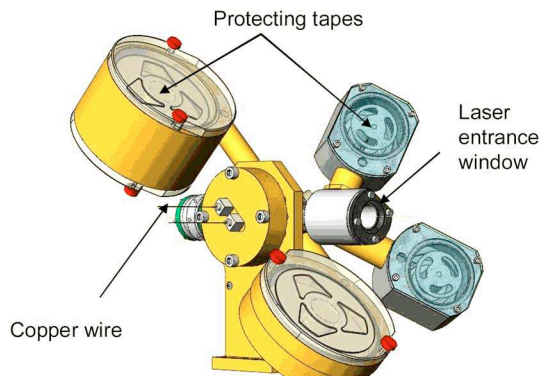

Fig. 2. (Color online) Vacuum chamber of the x-ray laser-plasma source.

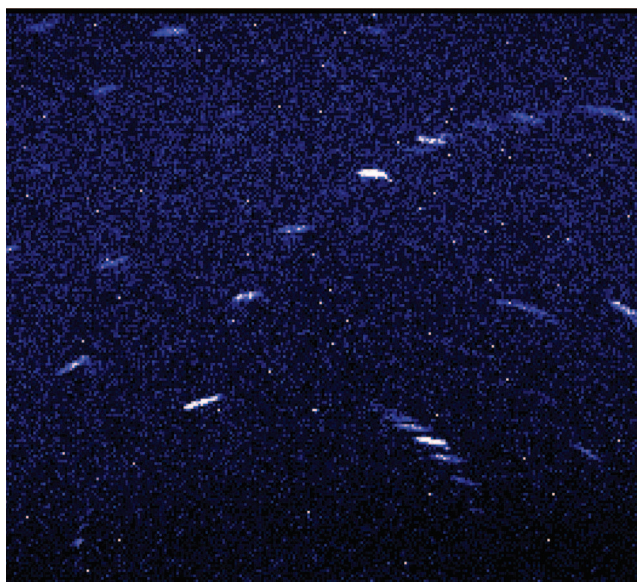

Fig. 3. Diffraction pattern from a lysozyme crystal.

exposed to a beam with a large two-dimensional convergence or divergence. We recorded the diffraction pattern of a lysozyme crystal, an enzyme widely distributed in animals and plants. The setup relies simply on a stationary crystal exposed to a divergent beam. The sample is mounted on a goniometric head placed at the outside of the vacuum chamber just behind the beryllium window, thus being perfectly protected from the debris. The x-ray beam diameter is reduced by a lead pinhole to the size of the crystal (a cube with 400  $\mu$ m sides), and the source angular spread is thus 1°. This value is easily adjusted by changing the hole. The CCD camera (1024  $\times$  1024 pixels of 13  $\mu$ m  $\times$  13  $\mu$ m) is placed 2.5 cm behind the sample, off the direction of the direct x-ray beam. Acquisition consists of summing images of exposition time equal to 20 s. This exposition time is chosen so that the probability of having more than one photon per pixel is negligible.<sup>20</sup> Consequently, each image is filtered to eliminate photons whose energy is above the Cu K lines, and the final image is then obtained by summing all the images. This basic filtering method can be further improved by use of event recognition techniques.<sup>21</sup> Figure 3 shows the image obtained after only 50 min of acquisition. The resulting diffraction pattern resembles

that of a summation of precession images, while the use of a divergent beam with a stationary crystal allows simultaneous data collection over the range of the divergence angle. The main effect of beam divergence–convergence on the diffraction spots is tangential elongation, known as a Kossel line.<sup>9</sup> For each spot the elongation is a function of the part of the angular spread of the source that can participate in the diffraction of the spot. Unfortunately, we observed that some high-energy photons get through our digital filtering by error, but their impacts are not larger than one or two pixels, and they do not change the evaluation of the diffraction pattern.

To collect a “complete” data set, one should record the diffraction pattern for different rotation angles of the crystal. But we underline that, for the same photon flux, the divergent beam geometry associated with the lack of x-ray optics allows us to significantly decrease the exposure time required to obtain a complete data set compared with that of the conventional oscillation method. Moreover, our objective is to study the structural modifications of a protein as it executes its function and not to determine an unknown structure. We will concentrate on specific locations in the protein, so a limited number of reflections will be necessary to determine local movements of the atoms.

In summary, we have presented an experimental setup for recording diffraction images of protein crystal with an ultrashort laser-plasma source. The whole setup lies on a single 3 m × 1.5 m optical table, which ensures the stability of a system producing  $5 \times 10^9$  hard x-ray photons/s/sr. The use of a divergent geometry with a sample located close to the source allows simultaneous data collection over the range of the divergence angle and optimized photon flux, decreasing the required exposure time. The signal-to-noise ratio we obtained in 50 min with a lysozyme crystal reaches  $10^3$  for the most intense diffraction spots. Subpicosecond time-resolved diffraction experiments are in progress.

The authors are grateful to Jean-Marc Sintès and Marcel Bierry for the realization of the vacuum chamber, Amplitude Technologies for the laser contrast measurement with a Sequoia third-order autocorrelator, and Marcel Knossow for providing protein crystal. This work was supported by the Region Ile-de-France under contract E.1300. A. Bonvalet’s e-mail address is adeline.bonvalet@polytechnique.fr.

## References

1. C. Rischel, A. Rouse, I. Uschmann, P. A. Albouy, J. P. Geindre, P. Audebert, J. C. Gauthier, E. Förster, J. L. Martin, and A. Antonetti, *Nature* **390**, 490 (1997).
2. C. W. Siders, A. Cavalleri, K. Sokolowski-Tinten, C. Toth, T. Guo, M. Kammler, M. H. von Hoegen, K. R. Wilson, D. von der Linde, and C. P. J. Barty, *Science* **286**, 1340 (1999).
3. C. Rose-Petruck, R. Jimenez, T. Guo, A. Cavalerri, C. W. Siders, F. Raski, J. A. Squier, B. C. Walker, K. Wilson, and C. J. Barty, *Nature* **398**, 310 (1999).
4. M. Bargheer, N. Zhavoronkov, Y. Gritsai, J. C. Woo, D. S. Kim, M. Woerner, and T. Elsaesser, *Science* **306**, 1772 (2004).
5. K. Kinoshita, H. Harano, K. Yoshii, T. Ohkubo, A. Fukasawa, K. Nakamura, and M. Uessaka, *Laser Part. Beams* **19**, 125 (2001).
6. P. Chen, I. V. Tomov, and P. M. Rentzepis, *J. Phys. Chem.* **104**, 10001 (1996).
7. F. Schotte, M. Lim, T. A. Jackson, A. V. Smirnov, J. Soman, J. S. Olson, G. N. Phillips Jr., M. Wulff, and P. A. Anfirud, *Science* **300**, 1944 (2003).
8. D. Boschetto, C. Rischel, I. Uschmann, J. Perez, S. Fourmaux, D. Hulin, E. Förster, and A. Rouse, *J. Appl. Crystallogr.* **36**, 348 (2003).
9. J. X. Ho, J. R. Ruble, T. R. McInnis, D. C. Carter, H. Huang, and W. M. Gibson, *Acta Crystallogr.* **58**, 2087 (2002).
10. Y. Jiang, T. Lee, W. Li, G. Ketwaroo, and C. G. Rose-Petruck, *Opt. Lett.* **27**, 963 (2002).
11. R. J. Tompkins, I. P. Mercer, M. Fettweis, C. J. Barnett, D. R. Klug, Lord G. Porter, I. Clark, S. Jackson, P. Matousek, A. W. Parker, and M. Towrie, *Rev. Sci. Instrum.* **69**, 3113 (1998).
12. G. Korn, A. Thoss, H. Stiel, U. Vogt, M. Richardson, T. Elsaesser, and M. Faubel, *Opt. Lett.* **27**, 866 (2002).
13. E. Fill, J. Bayerl, and R. Tommasini, *Rev. Sci. Instrum.* **73**, 2190 (2002).
14. D. C. Eder, G. Pretzler, E. Fill, K. Eidmann, and A. Saemann, *Appl. Phys. B: Photophys. Laser Chem.* **70**, 211 (2000).
15. Y. Hironaka, K. G. Nakamura, and K.-I. Kondo, *Appl. Phys. Lett.* **77**, 4110 (2000).
16. J. Kutzner, M. Silies, T. Witting, G. Tsilimis, and H. Zacharias, *Appl. Phys. B: Photophys. Laser Chem.* **78**, 949 (2004).
17. Ch. Reich, P. Gibbon, I. Uschmann, and E. Förster, *Phys. Rev. Lett.* **84**, 4846 (2000).
18. S. Backus, R. Bartels, S. Thompson, R. Dollinger, H. C. Kapteyn, and M. M. Murnane, *Opt. Lett.* **26**, 465 (2001).
19. S. J. Pestehe, G. J. Tallents, Y. Abou Ali, E. Turcu, M. Powers, and W. Shaikh, *Central Laser Facility Annual Report 1999/2000*, 217 (2000).
20. S. Cornaby, A. Reyes-Mena, H. K. Pew, P. W. Moody, T. Hughes, A. Stradling, and L. V. Knight, *J. X-Ray Sci. Technol.* **9**, 85 (2001).
21. A. Owens, T. Mineo, K. J. MacCarthy, and A. Wells, *Nucl. Instrum. Methods Phys. Res. A* **346**, 353 (1994).