



HAL
open science

Mechanisms governing the visco-elastic responses of living cells assessed by foam and tensegrity models

Patrick Canadas, Valérie Laurent, Patrick Chabrand, Daniel Isabey, Sylvie Wendling-Mansuy

► **To cite this version:**

Patrick Canadas, Valérie Laurent, Patrick Chabrand, Daniel Isabey, Sylvie Wendling-Mansuy. Mechanisms governing the visco-elastic responses of living cells assessed by foam and tensegrity models. *Medical and Biological Engineering and Computing*, 2003, 41, pp.733-739. <10.1007/BF02349982>. <hal-00088334>

HAL Id: hal-00088334

<https://hal.science/hal-00088334v1>

Submitted on 1 Aug 2006

HAL is a multi-disciplinary open access archive for the deposit and dissemination of scientific research documents, whether they are published or not. The documents may come from teaching and research institutions in France or abroad, or from public or private research centers.

L'archive ouverte pluridisciplinaire **HAL**, est destinée au dépôt et à la diffusion de documents scientifiques de niveau recherche, publiés ou non, émanant des établissements d'enseignement et de recherche français ou étrangers, des laboratoires publics ou privés.



Distributed under a Creative Commons CC BY 4.0 - Attribution - International License

Mechanisms governing the visco-elastic responses of living cells assessed by foam and tensegrity models

P. Cañadas^{1,2} V. M. Laurent¹ P. Chabrand² D. Isabey¹
S. Wendling-Mansuy^{2,3}

¹INSERM-UMR 492 Physiopathologie et Thérapeutique Respiratoires, Créteil, France

²CNRS-USR 2164 Laboratoire d'Aérodynamique et Biomécanique du Mouvement, Marseille, France

³CNRS-UMR 7052 Laboratoire de Biomécanique et Biomatériaux Ostéo-Articulaires, Créteil, France

Abstract—*The visco-elastic properties of living cells, measured to date by various authors, vary considerably, depending on the experimental methods and/or on the theoretical models used. In the present study, two mechanisms thought to be involved in cellular visco-elastic responses were analysed, based on the idea that the cytoskeleton plays a fundamental role in cellular mechanical responses. For this purpose, the predictions of an open unit-cell model and a 30-element visco-elastic tensegrity model were tested, taking into consideration similar properties of the constitutive F-actin. The quantitative predictions of the time constant and viscosity modulus obtained by both models were compared with previously published experimental data obtained from living cells. The small viscosity modulus values (10^0 – 10^3 Pa.s) predicted by the tensegrity model may reflect the combined contributions of the spatially rearranged constitutive filaments and the internal tension to the overall cytoskeleton response to external loading. In contrast, the high viscosity modulus values (10^3 – 10^5 Pa.s) predicted by the unit-cell model may rather reflect the mechanical response of the cytoskeleton to the bending of the constitutive filaments and/or to the deformation of internal components. The present results suggest the existence of a close link between the overall visco-elastic response of micromanipulated cells and the underlying architecture.*

Keywords—*Cell micromanipulation, Structural viscosity, Open unit-cell model, Multimodular cytoskeleton, Actin filaments, Viscosity modulus*

1 Introduction

THERE EXISTS an increasing amount of experimental evidence suggesting that the mechanical behaviour of the cytoskeleton (CSK) interacting with the cellular environment may determine biological functions of living cells, such as adhesion, differentiation, spreading and apoptosis, and their role in the healing of wounds (CHICUREL *et al.*, 1998; HARRIS *et al.*, 1980; THOUMINE *et al.*, 1996; WANG *et al.*, 1993; WANG and INGBER, 1994).

The CSK is a complex, three-dimensional, 'solid' network that is mainly composed of three types of filamentous biopolymers, namely actin filaments or F-actin, microtubules and intermediate filaments. In adherent cells, this CSK network ensures attachment to the substrate using focal adhesion

points. It has been established that the deformation of living cells subjected to external stresses depends strongly on the spatial rearrangement and/or the possible deformation of some of these interconnected biopolymers, without necessarily affecting the attachment conditions (INGBER and JAMIESON, 1985; SATCHER and DEWEY, 1996; STAMENOVIC and COUGHLIN, 1999; WANG *et al.*, 1993; WENDLING *et al.*, 2000b).

Structural models of the CSK have helped to elucidate the structural basis of the non-linear stress–strain relationship (i.e. strain hardening) systematically observed in adherent cells and the role of internal tension in the mechanical behaviour of the CSK (INGBER *et al.*, 1993; SATCHER and DEWEY, 1996; STAMENOVIC *et al.*, 1996; WENDLING *et al.*, 1999; 2000b). However, although these studies have made it possible to analyse the specific elastic properties of living cells, none of them has dealt, so far, with the cellular viscosity clearly found to play a role in many experimental studies (BAUSH *et al.*, 1999; LAURENT *et al.*, 2000; 2002b; MAKSYM *et al.*, 2000; MATHUR *et al.*, 2000; NEMOTO, 1982; SATCHER and DEWEY, 1996; SATO *et al.*, 1990; THOUMINE and OTT, 1997a; b; VALBERG and

ALBERTINI, 1985; VALBERG and FELDMAN, 1987; WANG *et al.*, 1993; WANG and INGBER, 1994; WANG, 1998; WU *et al.*, 1998; YAMADA *et al.*, 2000).

More specifically, the factors influencing the visco-elastic responses of cells subjected to external forces have not yet been clearly established. In fact, the large differences observed between cell visco-elasticity measurements suggest that the obtained values of the overall mechanical properties of the cells depend critically on

- (i) the experimental conditions, i.e. the stress applied, the rates of loading and of cell deformation, the type of cell tested and the adhesion conditions
- (ii) the physical properties of the cytoplasm components (CSK filaments, fluid, organelles, nucleus etc.)
- (iii) the mathematical formulations used to describe the probe-cell relationships (BOEY *et al.*, 1998; CHARRAS and NORTON, 2002; FABRY *et al.*, 1999; LAURENT *et al.*, 2002*b*; MOHRI and MOTRO, 1993; STAMENOVIC and COUGHLIN, 1999; YAMADA *et al.*, 2000).

In fact, the mechanical and mathematical models used so far to analyse the mechanical response of the cell consider the deformed cellular medium as an homogenous and continuous medium and thus need to be re-examined in terms of structural contribution. For instance, the early cell visco-elasticity models were mainly based on continuous medium theories and did not take the prior role of the spatial organisation of the cytoskeleton substructures into account (HOCHMUTH and WAUGH, 1987; SATCHER and DEWEY, 1996; SATO *et al.*, 1990; SCHMID-SCHONBEIN *et al.*, 1995; THOUMINE and OTT, 1997*a*; *b*). More recently, some investigators have suggested that the visco-elastic responses of living adherent cells obtained with certain techniques may, rather, reflect the heterogeneous and multi-modular visco-elastic character of the CSK structure, but such an idea has not been systematically evaluated for the wide spectrum of experimental data available (LAURENT *et al.*, 2002*a*; *b*; MATHUR *et al.*, 2000; YAMADA *et al.*, 2000).

In a recent study, we extended the applicability of the tensegrity concept to investigate the structural visco-elasticity of the cell. Using a visco-elastic 30-element tensegrity model, we have established that the spatial displacements of CSK filaments and the internal tension both contribute crucially to the overall visco-elastic properties of living adherent cells (CAÑADAS *et al.*, 2002). In the present study, we reconsider the visco-elastic responses of adherent and non-adherent cells obtained using a much broader range of techniques and we have used the visco-elastic tensegrity model and a visco-elastic open unit-cell model to determine the relevance of two types of mechanism: the spatial rearrangement and the bending of some cytoplasmic components such as F-actin, depending on the geometrical scales and the location at which the external loading was applied (COSTA *et al.*, 2002; INGBER *et al.*, 2000). The predictions given by these two structural models have been analysed and comparatively evaluated in relation to the wide range of experimental data. We were thus able to draw up a comprehensive picture of the respective weight of foam and tensegrity structural behaviours for the wide range of visco-elastic properties of living cells resulting from a large number of experimental techniques.

2 Method

2.1 Theoretical tensegrity model

The 30-element visco-elastic tensegrity structure shown in Fig. 1a has been previously described in CAÑADAS *et al.* (2002): it is composed of a discontinuous network of six rigid bars

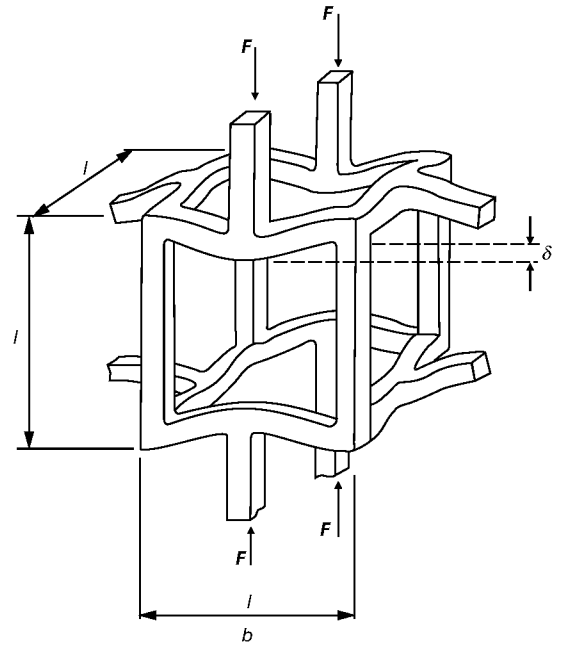
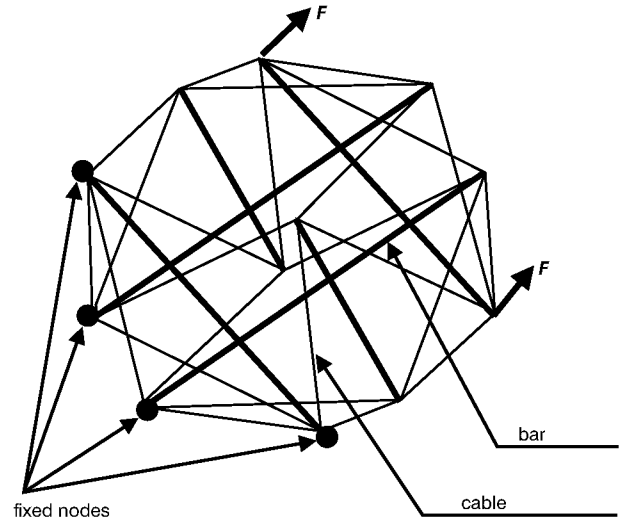

Fig. 1 (a) 30-element tensegrity model (6 bars and 24 elastic cables) fixed at 4 nodes (extremities of bars) and subjected to extension forces \mathbf{F} . (b) Open unit-cell model subjected to compression forces \mathbf{F}

compressed by a continuous network of 24 pre-stretched cables. The latter were assumed to behave like visco-elastic Voigt bodies, i.e. elastic elements arranged in parallel with viscous dash-pots. The visco-elastic tensegrity model was studied by the performing of creep tests, in which uni-axial extension was applied so that the parallel bars [1–8] and [6–11] were pulled apart by external forces applied at the endpoints of the bar [6–11] (see Fig. 1a). The ‘opposite’ nodes {1, 2, 4 and 8} remained fixed during the deformation of the tensegrity structure to mimic the attachment of the cells to a non-deformable and non-planar substrate (see Fig. 1a). The small strain values used in the visco-elastic tensegrity model were deduced from the resolution of the following system of differential equations (CAÑADAS *et al.*, 2002):

$$\{\mathbf{F}\} = [\mathbf{K}] \cdot \{\mathbf{u}\} + [\mathbf{C}] \cdot \{\dot{\mathbf{u}}\} \quad (1)$$

where the external force vector $\{\mathbf{F}\}$ is related to both the nodal displacement vector $\{\mathbf{u}\}$, associated with the global rigidity

matrix $[\mathbf{K}]$, and the rate of nodal displacement vector $\{\dot{\mathbf{u}}\}$, associated with the global damping matrix $[\mathbf{C}]$. Assuming small deformations, (1) is solved using a linearised incremental method that consists in computing the nodal displacement (given by the incremental vector $\{d\mathbf{u}_i\}$) as a function of the incremental time (dt) (CAÑADAS *et al.*, 2002).

$$\{d\mathbf{u}_i\} = [\mathbf{I}_d - \exp(-[\mathbf{C}_{i-1}]^{-1}[\mathbf{K}_{i-1}] \cdot dt)] \cdot [\mathbf{K}_{i-1}]^{-1} \{d\mathbf{F}_i\} \quad (2)$$

Let the nodal displacement be equal to zero at time $t=0$, and let \mathbf{I}_d be the identity matrix. The time constant τ_t and the apparent elasticity modulus E_t of the overall tensegrity model were obtained by $(\varepsilon-t)$ -curve fitting analysis*. The viscosity modulus was then deduced from the values of time constant τ_t and apparent elasticity modulus E_t as follows:

$$\eta_t = \tau_t \times E_t \quad (3)$$

2.2 Theoretical open unit-cell model

The mechanical behaviour of the cytoskeleton has also been studied using the theory of alveolar solids (GIBSON and ASHBY, 1988), which postulates that the overall deformation of the CSK associated with the foam is affined to the local deformation of a structural/mechanical unit associated with the open unit-cell model (see Fig. 1b). In this approach, only the F-actin network is taken into account in the aim of analysing the cellular mechanical behaviour. The open unit-cell model is characterised by the length l , the radius a and the Young modulus E of the constitutive bar associated with the actin filaments. The global deformation of the open unit-cell resulting from a uni-axial compressive force F is due to the individual bending δ of the constitutive elements (see Fig. 1b). An equivalent elasticity modulus E_u of the open unit-cell can therefore be defined by the ratio between the equivalent stress applied ($\sigma = F/l^2$) and the global deformation ($\varepsilon = \delta/l$), as follows (WENDLING *et al.*, 2000):

$$E_u = \sigma/\varepsilon = \frac{\pi}{4} E (L^*)^{-4} \quad (4)$$

where L^* ($=l/a$) is a normalised length characteristic of the scale of the unit-cell.

To determine the viscosity of this unit-cell model, we consider the visco-elastic behaviour of the bars in terms of a Voigt model, instead of the Kelvin linear solid model used by GIBSON and ASHBY (1988). During the creep test, a constant stress σ is applied to the open unit-cell, and the global deformation ε is given as a function of the time t , in line with the ‘Kelvin’ creep equation given by GIBSON and ASHBY (1988) using a Kelvin linear model, which gives the following ‘Voigt’ creep equation:

$$\varepsilon = \frac{\sigma}{C_1(\rho^*/\rho)^2 E} (1 - e^{-(E \cdot t)/\eta}) \quad (5)$$

Let E be the elasticity modulus and let η be the viscosity modulus of the Voigt model associated with the constitutive bars. The so-called ‘structural constant’ C_1 is taken to equal 1, and (ρ^*/ρ) is the density ratio, with ρ^* the density of the overall unit-cell and ρ the density of the constitutive bar (GIBSON and ASHBY, 1988). The time constant τ_u and viscosity modulus η_u of the open

unit-cell model are deduced from this creep equation, and τ_u is found to be equal to the time constant of the constitutive bar.

$$\tau_u \equiv \frac{\eta_u}{E_u} = \frac{\eta}{E} \quad (6)$$

Both models used similar physical properties of the CSK filaments, i.e. actin filaments with Young’s modulus $\sim 10^8$ Pa and radius ≈ 4.25 nm (STAMENOVIC and COUGHLIN, 1999). To determine the global time constant of both models, we have taken the values of the F-actin time constant obtained by PALMER *et al.* (1999) at low frequencies, i.e. $\tau_a \sim 10^0 - 10^1$ s. Based on (6), the open unit-cell model predicts a ‘global’ CSK time constant τ equal to the ‘local’ F-actin time constant τ_a , whereas we have recently shown that the visco-elastic tensegrity model predicts a ‘global’ CSK time constant smaller than the ‘local’ one, i.e. $\tau \sim [10^{-1} - 10^0] \times \tau_a$ (CAÑADAS *et al.*, 2002).

3 Results

The quantified visco-elastic properties of living cells, summarised in Table 1 in terms of order of magnitude, were determined from

- the previously published elasticity modulus (STAMENOVIC and COUGHLIN, 1999)
- an estimate of the time constant obtained here from both the open unit-cell model and the 30-element tensegrity model.

STAMENOVIC and COUGHLIN have predicted a CSK Young’s modulus in the $10^3 - 10^4$ Pa range with the open unit-cell model, whereas values in a lower range ($10^1 - 10^2$ Pa) have been predicted by the tensegrity model. In the present study, the values of the CSK time constant predicted by the unit-cell model are in the $10^0 - 10^1$ s range, whereas the $10^{-1} - 10^1$ s range is predicted by the tensegrity model. These predictions lead to viscosity modulus values in the $10^3 - 10^5$ Pa.s range predicted by the open unit-cell model (6) and in the $10^0 - 10^3$ Pa.s range predicted by the tensegrity model (3).

The theoretical values of the CSK viscosity modulus obtained by the two models are compared in Fig. 2 with previously published experimental measurements performed on several types of living cell. It emerged that the values of the viscosity modulus measured using the microplate device (MD) (THOUMINE and OTT, 1997a), atomic force microscopy (AFM) (WU *et al.*, 1998) and micropipette manipulation (MM) (LAURENT *et al.*, 2000; SATO *et al.*, 1990; THOUMINE and OTT, 1997b) fall in the range predicted by the unit-cell model, whereas the values of the viscosity modulus measured by magnetic twisting cytometry (MTC) (LAURENT *et al.*, 2002b; MAKSYM *et al.*, 2000; WANG and INGBER, 1994; WANG, 1998), optical tweezers (OTs) (LAURENT *et al.*, 2002b) and magnetic

Table 1 Order of magnitude of visco-elastic properties of living cells determined by open unit-cell model and 30-element tensegrity model. In each model, similar physical properties of CSK filaments are considered (see Section 2)

	Young’s modulus, Pa	Time constant, s	Viscosity modulus, Pa.s
Open unit-cell model	$\sim 10^3 - 10^4$	$\sim 10^0 - 10^1$	$\sim 10^3 - 10^5$
Tensegrity model	$\sim 10^1 - 10^2$	$\sim 10^{-1} - 10^1$	$\sim 10^0 - 10^3$

*KaleidaGraph software

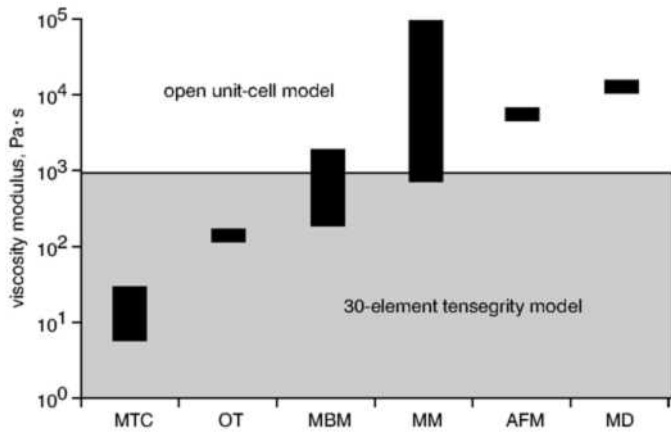

Fig. 2 Viscosity modulus values on logarithmic scale predicted by open unit-cell model and 30-element tensegrity model and measured experimentally by different microrheological techniques: magnetic twisting cytometry (MTC), optical tweezers (OT), magnetic beads microrheometry (MBM), micropipette manipulation (MM), atomic force microscopy (AFM) and microplate device (MD)

bead microscopy (MBM) (BAUSH *et al.*, 1999; NEMOTO, 1982; VALBERG and ALBERTINI, 1985; VALBERG and FELDMAN, 1987) fall in the range predicted by the tensegrity model.

4 Discussion

It has been well established that the cytoskeleton plays a crucial role in the mechanical responses of living cells (BEREITER-HAHN, 1994; INGBER *et al.*, 1995; MANIOTIS *et al.*, 1997; PAVALKO *et al.*, 1998). However, very few mechanical models have taken the discrete nature of the CSK into account. These models are mainly based on two classes of structural-deformation mechanism, namely the tensegrity concept, which focuses on the spatial rearrangement of the structural components, and the foam theory, which focuses on the bending of the constitutive elements (SATCHER and DEWEY, 1996; STAMENOVIC and COUGHLIN, 2000; VOLOKH *et al.*, 2000; WENDLING *et al.*, 1999).

In the present study, each of these two classes of structural mechanism is characterised by a particular model, i.e. the 30-element tensegrity model and the open unit-cell model. Based on the tensegrity model, the overall deformation and the time-dependent mechanical responses of the CSK are determined mainly by the internal tension and the spatial displacements of the individual, tensed CSK filaments. Based on the open unit-cell model, the overall deformation of the CSK and its visco-elastic response basically result from a similar amount of bending undergone by individual CSK filaments. In fact, the basic mechanical laws (e.g. the stress-strain curves or stress-hardening) have been established for different tensegrity models obtained by varying the length of the elements, the internal tension and the number of constitutive elements, as well as the limit conditions (e.g. the type of external loading and the number of fixed nodes) (KEBICHE *et al.*, 1999; MOHRI and MOTRO, 1993; STAMENOVIC and COUGHLIN, 2000; VOLOKH *et al.*, 2000; WENDLING *et al.*, 2002; 2003). The open unit-cell model, which is the elementary unit defined in foam theory (GIBSON and ASHBY, 1988) has previously been used by SATCHER and DEWEY (1996) to analyse the influence of the cytoplasmic F-actin network in the mechanical properties of the endothelial cell cytoskeleton.

The behaviour of the two structural models tested here can be characterised by their specific relationships (see (2), (4) and (5))

between the local (i.e. the components) and the global (i.e. the overall structure) properties (i.e. mechanical and geometrical). Owing to the differences between these relationships in the two models, the standard F-actin physical properties used for each structural model yield predicted values of viscosity and elasticity in two distinct ranges. The 30-element tensegrity model predicts values of cellular viscosity in the range 10^0 – 10^3 Pa.s and values of cellular elasticity in the range 10^1 – 10^2 Pa. In contrast, the open unit-cell model predicts values of cellular viscosity in the range 10^3 – 10^5 Pa.s and values of cellular elasticity in the range 10^3 – 10^4 Pa (see Table 1 and the results of STAMENOVIC and COUGHLIN (1999)). It is interesting to note that these ranges do not overlap.

Thus it would be possible to delineate, within the wide spectrum of techniques and data, which one of the tensegrity and foam mechanisms mainly governs the cellular response. Indeed, the predictions given by the open unit-cell model were found to be in agreement with the assumption that, at a very local level and/or in a non-specific region (e.g. outside a focal or adhesion point), individual bending of short actin filaments may be responsible for the mechanical responses of the CSK (WENDLING *et al.*, 2000a). In contrast, the predictions given by the 30-element tensegrity model have been shown to be consistent with

- (i) either a global response of the overall CSK structure, involving spatial displacements of larger CSK subdomains, including the strongly tensed stress fibres at a global level (STAMENOVIC *et al.*, 1996; STAMENOVIC and COUGHLIN, 1999; 2000; WENDLING *et al.*, 1999; 2000a)
- (ii) or a local response of a short F-actin substructure, such as the cortical submembrane structure, as recently proposed by LAURENT *et al.* (2000).

In agreement with these previous studies, we consider, in the present analysis, that measured cellular visco-elastic properties greatly depend on the mechanical properties of structural elements which, being organised at different locations and scales within the cell, respond in a manner that greatly depends on the types of assembly and loading.

4.1 Assessment of the CSK mechanical properties in response to 'non CSK-specific' forces: the open unit-cell model

As suggested by STAMENOVIC and COUGHLIN (1999), cellular viscosity and elasticity moduli measured by micropipette manipulation, atomic force microscopy or microplate device can be accurately predicted by the open unit-cell model, because these mechanical responses result from the bending of short actin filaments on the local scale or from the distortion of internal cellular components at the global cellular scale. It is worth noting that, to measure cellular viscosity using these three types of cellular micromanipulation technique, the applied forces have mostly been applied to the cell surface but not specifically to the point of convergence (adhesion plaques) of the highly polymerised internal CSK structure. This is because there is no specific linkage, such as that provided by mechanoreceptors of the integrin-type, between the cell sensor (i.e. the probe) and the cytoskeleton.

In a study on the shear and elastic moduli of the cytoplasm in F-actin gels and endothelial cells manipulated by micropipettes, SATCHER and DEWEY (1996) suggested that the cellular mechanical response may be mainly due to the local, interconnected F-actin network, the deformation of which results from the individual bending of some of the constitutive actin filaments. Moreover, during compression or extension using the microplate device, the deformation of the overall cell structure involves the global deformation of many cellular components,

including the nucleus and the cytoplasm (CAILLE *et al.*, 2001; HENON *et al.*, 1999). With these non CSK-specific techniques, the deformation of the cytoskeleton structure could not be separated from the other components of the cytoplasm. During atomic force microscopy measurements, a very local compression (given to be at the nanoscale) is applied at the cell surface, regardless of the mechanoreceptor sites. The probe indentation occurs either at the top (near the nucleus) or at the periphery (filopode or lamellipode) of the cell and therefore could only deform a cellular region limited to a neighbourhood close to the probe (CHARRAS and NORTON, 2002; MATHUR *et al.*, 2000). MATHUR *et al.* (2000) have reported that the cell response to such a local compressive force is variable, depending on the local shape of the cell as well as the point at which such a non CSK-specific force is applied.

On the whole, the present results suggest that, when stresses are applied using such non CSK-specific manipulation techniques, they may not be totally and specifically transmitted to the inner CSK structure, and hence, it is reasonable to expect a local response. Note that local and non CSK-specific cellular visco-elastic responses also include the local accommodation of the cell structure to the stress, as already mentioned in a previous study (HEIDEMANN *et al.*, 1999).

4.2 Assessment of CSK mechanical properties in response to 'CSK-specific' forces: the tensegrity model

The cellular viscosity and elasticity moduli measured by magnetic twisting cytometry, optical tweezers and magnetic bead microrheometry were found to fall in the range of values predicted by the 30-element tensegrity model and thus differ greatly from the values obtained with the microplate, atomic force microscopy and micropipette manipulation techniques (see Fig. 2).

In fact, in the experimental devices used in these studies, the stresses, induced mainly by extension forces, were specifically applied to the CSK by beads anchored to transmembrane receptors such as integrins (magnetic twisting cytometry, optical tweezers) (LAURENT *et al.*, 2002b) or to the inner CSK filaments (magnetic bead microrheometry) (VALBERG and ALBERTINI, 1985; VALBERG and FELDMAN, 1987). As suggested in previous studies on cellular tensegrity (INGBER and JAMIESON, 1985; INGBER *et al.*, 2000; STAMENOVIC *et al.*, 1996; WANG *et al.*, 1993; WENDLING *et al.*, 1999), it now emerges that the overall CSK structure strongly contributes to the cellular visco-elastic properties evaluated by these CSK-specific techniques, simply because the probing system implies a specific CSK attachment, and the extension forces are therefore directly applied to the entire CSK structure.

Moreover, by analysing the mechanical responses of living adherent epithelial cells obtained by magnetic twisting cytometry with an heterogeneous model, LAURENT *et al.* (2002a) have identified two different CSK subdomains with their specific visco-elastic responses that would respond to the same stress applied by integrin mechanoreceptors: a thin, submembranous actin network of short filaments called 'cortical' actin CSK, and a large-scale, internal F-actin network, including highly polymerised stress fibres, called 'cytosolic' actin CSK. It appears from the Laurent *et al.* analysis that

- (a) both the cortical and cytosolic CSK components respond with a variable but complementary weight to the stress
- (b) the values of elastic moduli so obtained remain in the 'lower' range of predicted values that pertains to tensegrity models.

In other words, the cortical actin CSK stretched specifically through CSK mechanoreceptors would behave as a tensegrity structure, whereas stresses applied non-specifically to the CSK

would rather lead to a different behaviour, namely a foam behaviour, as suggested above. One possible explanation could be that, owing to the heterogeneity of the cell structure, specific or non-specific stretching, twisting or compression leads to different apparent properties.

4.3 Comparison with the Stamenovic and Coughlin cellular elasticity estimates

STAMENOVIC and COUGHLIN (1999) compared the cell elasticity moduli determined experimentally using several methods, including magnetic twisting cytometry, optical tweezers, atomic force microscopy, magnetic bead microrheometry, micropipette manipulation and microplate device. The authors attempted to explain the discrepancies between the experimental data in terms of the magnitude of the deformation of the cell tested using these devices: the open unit-cell model yielded an elastic modulus (10^2 – 10^4 Pa) consistent with measurements taken when attempting to apply a large compressive stress to the cell using microplate, cell poking, atomic force microscopy and magnetic bead microrheometry methods, where the bending of the CSK filaments was taken to be the key mechanism for the resistance to large compression (STAMENOVIC and COUGHLIN, 1999). On the other hand, they suggested that the tensegrity model yielded a much lower elastic modulus (10^1 – 10^2 Pa), which is consistent with measurements obtained using methods such as magnetic twisting cytometry and micropipette manipulation (given by SATO *et al.* (1990)) at presumed low applied stress levels, where the prestress and the architecture were thought to be the prior determinants of the cells' elastic responses (STAMENOVIC and COUGHLIN, 1999).

However, these authors did not take into account either the scale of different CSK subdomains subjected to external loading or the conditions under which the external forces were applied to the cells, and we now propose some new explanations for the differences between the experimental data. In fact, the CSK structure in non-adherent cells is strictly submembranous, and there is no CSK filament in the inner cytoplasm. Thus it is reasonable to consider that micropipette manipulations greatly deform this cortical CSK by applying compressive forces throughout the cell membrane, without specifically affecting the transmembrane mechanical receptors linked to the actin filaments, such as those forming the integrin complex.

Interestingly, it was observed here that, the greater the micropipette diameter, the smaller the elasticity modulus turned out to be; SATO *et al.* (1990), for instance, used a 4 μ m diameter micropipette and obtained a cell elasticity of $\sim 10^2$ Pa, whereas LAURENT *et al.* (2000) used a 3.8 μ m diameter micropipette and obtained a cell elasticity of $\sim 3 \times 10^2$ Pa, and THOUMINE and OTT (1997b) used a 2.8 μ m diameter micropipette and obtained a cell elasticity of $\sim 1.8 \times 10^4$ Pa. The larger the diameter of the micropipette, the larger the CSK subdomain explored experimentally has to be. THOUMINE and OTT (1997b) probably measured the mechanical properties of a short cortical CSK domain, in line with the predictions of the open unit-cell model, whereas SATO *et al.* (1990) probably applied their micropipette manipulation forces to a larger-sized cellular domain in which some elements, such as the nucleus and/or the or the cytosolic fluid, were undergoing spatial displacements, in line with the lower elasticity modulus values predicted by the tensegrity model.

On the other hand, the cellular elasticity modulus values measured using the magnetic bead microrheometry (MBM) technique, as reported by Stamenovic and Coughlin, seem to be overestimated in comparison with the predictions of the open unit-cell model (STAMENOVIC and COUGHLIN, 1999). During MBM, the location of the bead in the cytoplasm cannot be

controlled well, and some of the beads may be connected to the CSK filaments. In addition, VALBERG and FELDMAN (1987) have reported that the size of the magnetic beads can dramatically influence cellular mechanical measurements when the size of the bead is smaller than the pores characteristic of the surrounding CSK; the corresponding measurements may then reflect the visco-elastic properties of both the CSK structure and the surrounding fluid.

Nevertheless, the differences observed here between the possible mechanisms involved in CSK deformation are not mutually exclusive and should provide complementary ways to evaluate the overall cellular mechanical response. Indeed, the overall cellular response may involve a combination of many mechanisms at different points and scales in the cell, including the individual bending of some CSK filaments along with (and mechanically 'connected' to) the spatial displacement of some CSK filaments that may or may not undergo the same bending process. These combinations of many mechanisms would explain why some experimental measurements are in agreement with the predictions of either the open unit-cell model or the tensegrity model, or with both models, as occurs in the case of micropipette manipulation and magnetic bead microrheometry.

Obviously, the real architecture of living cell cytoskeleton corresponds to a more complex structure than the present tensegrity and foam models. Hence, these models could be seen as too grossly oversimplified to describe accurately the CSK network. However, in a first attempt to describe the multifactor processes governing the CSK mechanical responses, it is of interest to consider rival, but relatively simple, structural models. Indeed, many features regarding the CSK architecture and its mechanical response remain to be identified and understood. We still are at the stage where such elementary models bring new and relevant knowledge concerning the fundamental role of the CSK structure in cellular mechanical response (CAÑADAS *et al.*, 2002; INGBER *et al.*, 2000; SATCHER and DEWEY, 1996; STAMENOVIC and COUGHLIN, 1999; WENDLING *et al.*, 2000a,b).

In addition, we have shown in previous studies that the 30-element tensegrity model is representative of spherical tensegrity structures and can be adapted to analyse the multi-modular CSK network (LAURENT *et al.* 2002a; WENDLING *et al.*, 2003). Similarly, the present open unit-cell model has to be seen as a structural and mechanical unit of the whole F-actin network (SATCHER and DEWEY, 1996). These structural models can be enhanced by increasing the number of constitutive elements and/or the types of element. Also, the geometric and mechanical properties of each element or group of elements could be taken distinctly (e.g. non-linear visco-elastic laws). Thus further studies could be performed by taking into account other parameters related to the apparent non-Newtonian visco-elastic response of cells, such as the cytoplasmic fluid properties, the nucleus role and the dynamic connectivity between CSK filaments, as well as the physical properties of the substrate.

References

BAUSH, A. R., MOLLER, W., and SACKMAN, E. (1999): 'Measurements of local viscoelasticity and forces in living cells by magnetic tweezers', *Biophys. J.*, **76**, pp. 573–579

BEREITER-HAHN, J. (1994): 'Functional morphology and biomechanics', *Verh. Dtsch. Zool. Ges.*, **87**, pp. 129–145

BOEY, S. K., BOAL, D. H., and DISHER, D. E. (1998): 'Simulations of the erythrocyte cytoskeleton at large deformations I: microscopic modes', *Biophys. J.*, **75**, pp. 1573–1583

CAILLE, N., THOUMINE, O., TARDY, Y., and MEISTER, J.-J. (2001): 'Contribution of the nucleus to the mechanical properties of endothelial cells', *J. Biomech.*, **35**(2), pp. 177–187

CAÑADAS, P., LAURENT, V., ODDOU, C., ISABEY, D., and WENDLING, S. (2002): 'A cellular tensegrity model to analyse the structural viscoelasticity of the cytoskeleton', *J. Theor. Biol.*, **218**, pp. 155–173

CHARRAS, G. T., and NORTON, M. A. (2002): 'Determination of cellular strains by combined atomic force microscopy and finite element modeling', *Biophys. J.*, **83**, pp. 858–879

CHICUREL, M. E., CHEN, C. S., and INGBER, D. E. (1998): 'Cellular control lies in the balance of forces', *Curr. Opin. Cell Biol.*, **10**(2), pp. 232–239

COSTA, K. D., HUCKER, W. J., and YIN, F. C.-P. (2002): 'Buckling of actin stress fibers: a new wrinkle in the cytoskeletal tapestry', *Cell Motil. Cytoskel.*, **52**, pp. 266–274

FABRY, B., MAKSYM, G. N., HUBMAYR, R. D., BUTLER, J. P., and FREDBERG, J. J. (1999): 'Implications of heterogeneous bead behavior on cell mechanical properties measured with magnetic twisting cytometry', *J. Magn. Magn. Mater.*, **194**, pp. 120–125

GIBSON, L. J., and ASHBY, M. F. (Eds) (1988): 'Cellular solids, structure and properties' (Pergamon Press, 1988), p. 358

HARRIS, A. K., WILD, P., and STOPAK, D. (1980): 'Silicone rubber substrata: a new wrinkle in the study of cell locomotion', *Science*, **208**, pp. 177–179

HEIDEMANN, S. R., KAECH, S., BUXBAUM, R. E., and MATUS, A. (1999): 'Direct observations of the mechanical behaviors of the cytoskeleton in living fibroblasts', *J. Cell Biol.*, **145**, pp. 109–122

HENON, S., LENORMAND, G., RICHERT, A., and GALLET, F. (1999): 'A new determination of the shear modulus of the human erythrocyte membrane using optical tweezers', *Biophys. J.*, **76**, pp. 1145–1151

HOCHMUTH, R. M., and WAUGH, R. E. (1987): 'Erythrocyte membrane, elasticity and viscosity', *Ann. Rev. of Physiol.*, **49**, pp. 209–219

INGBER, D. E., and JAMIESON, J. D. (1985): 'Cells as tensegrity structures: architectural regulation of histodifferentiation by physical forces transduced over basement membrane', in ANDERSON, L., GAHMBERG, C., and EKBLUM, P. (Eds): 'Gene expression during normal and malignant differentiation' (San Diego Academic Press, London, 1985), pp. 13–32

INGBER, D. E., KARP, S., PLOPPER, G., HANSEN, L., and MOONEY, D. (1993): 'Mechanochemical transduction across extracellular matrix and through the cytoskeleton', in 'Physical forces and mammalian cell' (Academic Press Inc., 1993), pp. 61–78

INGBER, D. E., PRUSTY, D., SUN, Z., BETENSKY, H., and WANG, N. (1995): 'Cell shape, cytoskeleton mechanics and cell cycle control in angiogenesis', *J. Biomech.*, **28**(12), pp. 1471–1484

INGBER, D. E., HEIDEMANN, S. R., LAMOUREUX, P., and BUXBAUM, R. E. (2000): 'Opposing views on tensegrity as a structural framework for understanding cell mechanics', *J. Appl. Physiol.*, **89**, pp. 1663–1678

KEBICHE, K., KAZI-AAOUAL, M. N., and MOTRO, R. (1999): 'Geometrical nonlinear analysis of tensegrity systems', *Eng. Struct.*, **21**, pp. 864–876

LAURENT, V., PLANUS, E., ISABEY, D., LACOMBE, C., and BUCHERER, C. (2000): 'Propriétés mécaniques de cellules épithéliales évaluées par micromanipulation cellulaire et magnétocytométrie', in GAMAC S. B. (Ed.): 'Mécanotransduction 2000—Matériaux et Structures des Sciences de l'Ingénieur et du Vivant' (Editions TEC&DOC/Lavoisier, Cachan, 2000), pp. 373–379

LAURENT, V. M., CAÑADAS, P., PLANUS, E., FODIL, R., ASNACIOS, A., WENDLING, S., and ISABEY, D. (2002a): 'Tensegrity behavior of cortical and cytosolic cytoskeletal components in twisted living adherent cells', *Acta Biotheoretica*, **50**, pp. 331–356

LAURENT, V. M., HENON, S., PLANUS, E., FODIL, R., BALLAND, M., ISABEY, D., and GALLET, F. (2002b): 'Assessment of mechanical properties of adherent living cells by bead micromanipulation: comparison of magnetic twisting cytometry vs optical tweezers', *J. Biomech. Eng.*, **124**, pp. 408–421

MAKSYM, G. N., FABRY, B., BUTLER, J. P., NAVAJAS, D., TSCHUMPERLIN, D. J., LAPORTE, J. D., and FREDBERG, J. J. (2000): 'Mechanical properties of cultured human airway smooth muscle cells from 0.05 to 0.4 Hz', *J. Appl. Physiol.*, **89**, pp. 1619–1632

MANIOTIS, A. J., CHEN, C. S., and INGBER, D. E. (1997): 'Demonstration of mechanical connections between integrins, cytoskeletal filaments and nucleoplasm that stabilize nuclear structure', *Proc. Natl. Acad. Sci.*, **94**, pp. 849–854

- MATHUR, A. B., TRUSKEY, G. A., and REICHERT, W. M. (2000): 'Atomic force and total reflection fluorescence microscopy for the study of force transmission in endothelial cells', *Biophys. J.*, **78**, pp. 1725–1735
- MOHRI, F., and MOTRO, R. (1993): 'Static and kinematic determination of generalized space reticulated systems', *Struct. Eng. Rev.*, **5**, pp. 231–237
- NEMOTO, I. (1982): 'A model of magnetization and relaxation of ferromagnetic particles in the lung', *IEEE Trans. Biomed. Eng.*, **29**, pp. 745–752
- PALMER, A., MASON, T. G., XU, J., KUO, S. C., and WITZ, D. (1999): 'Diffusing wave spectroscopy microrheology of actin filament networks', *Biophys. J.*, **76**, pp. 1063–1071
- PAVALKO, F. M., CHEN, N. X., TURNER, C. H., BURR, D. B., ATKINSON, S., HSIEH, Y. F., QIU, J., and DUNCAN, R. L. (1998): 'Fluid shear-induced mechanical signaling in MC3T3-E1 osteoblasts requires cytoskeleton-integrin interactions', *Am. J. Physiol.*, **275**, pp. C1591–C1601
- SATCHER, R. L., and DEWEY, C. F. (1996): 'Theoretical estimates of mechanical properties of the endothelial cell cytoskeleton', *Biophys. J.*, **71**, pp. 109–118
- SATO, M., THERET, D. P., WHEELER, L. T., OHSHIMA, N., and NEREM, R. M. (1990): 'Application of the micropipette technique to the measurement of cultured porcine aortic endothelial cell viscoelastic properties', *J. Biomech. Eng.*, **112**, pp. 263–268
- SCHMID-SCHONBEIN, G. W., KOSAWADA, T., SKALAK, R., and CHIEN, S. (1995): 'Membrane model of endothelial cells and leukocytes. A proposal for the origin of a cortical stress', *J. Biomech. Eng.*, **117**, pp. 171–178
- STAMENOVIC, D., INGBER, D. E., WANG, N., and FREDBERG, J. J. (1996): 'A microstructural approach to cytoskeletal mechanics based on tensegrity', *J. Theor. Biol.*, **181**, pp. 125–136
- STAMENOVIC, D., and COUGHLIN, M. F. (1999): 'The role of prestress and architecture of the cytoskeleton and deformability of cytoskeletal filaments in mechanics of adherent cells: a quantitative analysis', *J. Theor. Biol.*, **201**, pp. 63–74
- STAMENOVIC, D., and COUGHLIN, M. F. (2000): 'A quantitative model of cellular elasticity based on tensegrity', *J. Biomech. Eng.*, **122**, pp. 39–43
- THOUMINE, O., OTT, A., and LOUVARD, D. (1996): 'Critical centrifugal forces induce adhesion rupture or structural reorganization in cultured cells', *Cell Motil. Cytoskeleton*, **33**
- THOUMINE, O., and OTT, A. (1997a): 'Time scale dependent viscoelastic and contractile regimes in fibroblasts probed by microplate manipulation', *J. Cell Sci.*, **110**, pp. 2109–2116
- THOUMINE, O., and OTT, A. (1997b): 'Comparison of the mechanical properties of normal and transformed fibroblasts', *Biorheology*, **34**, pp. 309–326
- VALBERG, P. A., and ALBERTINI, D. F. (1985): 'Cytoplasmic motions, rheology and structure probed by a novel magnetic particle method', *J. Cell Biol.*, **101**, pp. 130–140
- VALBERG, P. A., and FELDMAN, H. A. (1987): 'Magnetic particle motions within living cells (Measurement of cytoplasmic viscosity and motile activity)', *Biophys. J.*, **52**, pp. 551–561
- VOLOKH, K. Y., VILNAY, O., and BELSKY, M. (2000): 'Tensegrity architecture explains linear stiffening and predicts softening of living cells', *J. Biomech.*, **33**, pp. 1543–1549
- WANG, N., BUTLER, J., and INGBER, D. (1993): 'Mechanotransduction across the cell surface and through the cytoskeleton', *Science*, **260**, pp. 1124–1127
- WANG, N., and INGBER, D. E. (1994): 'Control of cytoskeletal mechanics by extracellular matrix, cell shape and mechanical tension', *Biophys. J.*, **66**, pp. 1–9
- WANG, N. (1998): 'Mechanical interactions among cytoskeletal filaments', *Hypertension*, **32**, pp. 162–165
- WENDLING, S., ODDOU, C., and ISABEY, D. (1999): 'Stiffening response of a cellular tensegrity model', *J. Theor. Biol.*, **196**(3), pp. 309–325
- WENDLING, S., ODDOU, C., and ISABEY, D. (2000a): 'Approche structurale de la mécanique du cytosquelette: Solide alvéolaire vs modèle de tensegrité', *Compte Rendu de l'Académie des Sciences, Série Ib (Biomécanique)*, **328**, pp. 97–104
- WENDLING, S., PLANUS, E., LAURENT, V. M., BARBE, L., MARY, A., ODDOU, C., and ISABEY, D. (2000b): 'Role of cellular tone and microenvironmental conditions on cytoskeleton stiffness assessed by tensegrity model', *Eur. Phys. J. AP*, **9**, pp. 51–62
- WENDLING, S., CAÑADAS, P., ODDOU, C., and MEUNIER, A. (2002): 'Interrelations between elastic energy and strain in a tensegrity model; contribution to the analysis on the mechanical response in living cells', *Comput. Methods Biomech. Biomed. Eng.*, **5**, pp. 1–6
- WENDLING, S., CAÑADAS, P., and CHABRAND, P. (2003): 'Toward a generalized tensegrity model describing the mechanical behaviour of the cytoskeleton structure', *Comput. Methods Biomech. Biomed. Eng.*, **1**, pp. 1–8
- WU, H. W., KUHN, T., and MOY, V. T. (1998): 'Mechanical properties of L929 cells measured by atomic force microscopy: effects of anticytoskeletal drugs and membrane crosslinking', *Scanning*, **20**, pp. 389–397
- YAMADA, S., WIRTZ, D., and KUO, S. C. (2000): 'Mechanics of living cells measured by laser tracking microrheology', *Biophys. J.*, **78**, pp. 1736–1747