



**HAL**  
open science

## A Note On Solitary Wave Solutions of the Compound Burgers-Korteweg-de Vries Equation”

Claire David, Rasika Fernando, Zhaosheng Feng

► **To cite this version:**

Claire David, Rasika Fernando, Zhaosheng Feng. A Note On Solitary Wave Solutions of the Compound Burgers-Korteweg-de Vries Equation”. *Physica A: Statistical Mechanics and its Applications*, 2007, 375 (1), pp.44-50. 10.1016/j.physa.2006.09.008 . hal-00087812

**HAL Id: hal-00087812**

**<https://hal.science/hal-00087812>**

Submitted on 26 Jul 2006

**HAL** is a multi-disciplinary open access archive for the deposit and dissemination of scientific research documents, whether they are published or not. The documents may come from teaching and research institutions in France or abroad, or from public or private research centers.

L'archive ouverte pluridisciplinaire **HAL**, est destinée au dépôt et à la diffusion de documents scientifiques de niveau recherche, publiés ou non, émanant des établissements d'enseignement et de recherche français ou étrangers, des laboratoires publics ou privés.

# A Note On “Solitary Wave Solutions of the Compound Burgers-Korteweg-de Vries Equation”

Claire David<sup>†\*</sup>, Rasika Fernando<sup>†</sup>, and Zhaosheng Feng<sup>‡</sup>

<sup>†</sup>Université Pierre et Marie Curie-Paris 6

Laboratoire de Modélisation en Mécanique, UMR CNRS 7607,  
Boîte courrier n<sup>o</sup>162, 4 place Jussieu, 75252 Paris, cedex 05, France

<sup>‡</sup>Department of Mathematics, University of Texas-Pan American, Edinburg, TX 78541, USA

## Abstract

The goal of this note is to construct a class of traveling solitary wave solutions for the compound Burgers-Korteweg-de Vries equation by means of a hyperbolic ansatz. A computational error in a previous work has been clarified.

## 1 Introduction

Consider the following equations:

◇ KdV:

$$u_t + \alpha uu_x + su_{xxx} = 0, \quad (1)$$

◇ Burgers:

$$u_t + \alpha uu_x + \mu u_{xx} = 0, \quad (2)$$

◇ modified KdV:

$$u_t + \beta u^2 u_x + su_{xxx} = 0 \quad (s > 0) \quad (3)$$

These three equations play crucial roles in the history of wave equations. Equation (1) is named after its use by Burgers [1] for studying turbulence in 1939. Equation (2) was first suggested by Korteweg and de Vries [2] who used it as a nonlinear model

---

\*Corresponding author: david@lmm.jussieu.fr; fax number: (+33) 1.44.27.52.59.

to study the change of form of long waves advancing in a rectangular channel. It was shown by Wadati [3] that equation (3) can be solved exactly by the inverse scattering method and the N-soliton solution can be expressed explicitly which is essentially the same as that in the KdV equation. A combination of these three equations leads to the so-called compound Burgers-Korteweg-de Vries (cBKDV) equation:

$$u_t + \alpha uu_x + \beta u^2 u_x + \mu u_{xx} + s u_{xxx} = 0, \quad (4)$$

where  $\alpha$ ,  $\beta$ ,  $\mu$  and  $s$  are real constants. The first term is the *instationary term*. The second and third ones are two *non-linear convective terms* with different orders. The fourth is the so-called *viscous dissipative term*:  $\mu$ , which refers to a positive quantity, denotes the viscosity. The last one is the *dispersive term*. In order for the traveling wave to keep its appearance all through its propagation, an equilibrium is required between convective and dispersive terms.

The coefficient  $\alpha$ , which usually refers to the wave celerity, will be assumed positive in the following. The case  $\alpha < 0$  can be easily deduced from the latter one by adimensionalization.

The coefficient of the  $u_{xxx}$  term in the modified KDV equation being strictly positive, we restrain our study to the case  $s > 0$  in (4). As in [8], the quantity  $-s\beta$  is supposed positive, which results in  $\beta < 0$ .

In the past few years, the cBKDV equation has attracted continuous attention from a diverse group of researchers. Especially, the traveling wave solution has been explored extensively. An exact solution was presented by Wang [4] using the homogeneous balance method. Feng [5-7] investigated the same problem by applying the first integral method and the method of variation of parameters, respectively. A more general result was obtained by Parkes and Duffy [8, 9] using the automated tanh-function method and adapting the method of variation of parameters used in [7]. A generalization of equation (4) with higher-order nonlinearities in one- and two- dimensional spaces was treated by Zhang et al. [10, 11] using the method of undetermined coefficients, and by Li et al. [12] applying the tanh-function method and direct assumption method with symbolic computations, respectively. Describing traveling waves of nonlinear evolution equations has been one of basic problems in theoretical and experimental physics. Traveling wave solutions to many nonlinear one-dimensional evolution equations can be derived from a set of ordinary differential equations that can be interpreted as a flow in a phase space. In the last century, experiments on one-dimensional states of nonlinear traveling wave convection were undertaken by many researchers in the narrow annular cell, condensed matter physics, plasma, particle physics, and so on [13-16].

In the present work, we aim at extending results in a previous work [5], in which traveling wave solutions of the cBKDV equation were exhibited as combinations of bell-profile waves and kink-profile waves. Following [5], we assume that equation (4) has the traveling wave solution of the form

$$u(x, t) = u(\xi), \quad \xi = x - vt \quad (5)$$

where  $v$  is the wave velocity. Substituting (5) into equation (4), performing an integration with respect to  $\xi$  and setting the integration constant to zero yields

$$u''(\xi) + ru'(\xi) + au(\xi)^3 + bu(\xi)^2 + cu(\xi) = 0, \quad (6)$$

where  $r = \frac{\mu}{s}$ ,  $a = \frac{\beta}{3s}$ ,  $b = \frac{\alpha}{2s}$  and  $c = -\frac{v}{s}$ . Equation (6) is a second-order nonlinear ordinary differential equation. We know that if all coefficients of equation (4) are nonzero, equation (6) does not pass the Painlevé test [17, 18].

The rest of the paper is organized as follows. In Section 2, a class of traveling wave solutions to the cBKDV equation is presented by using a hyperbolic ansatz and the types of traveling waves are discussed theoretically. Numerical simulations for a couple of sets of parameters are illustrated. A calculational error in the previous literature is clarified at the end of this section. In Section 3, we give a brief discussion.

## 2 Traveling Solitary Waves

### 2.1 Hyperbolic Ansatz

The phase plane analysis in Section 3 of Paper [5] provides us useful information when we construct traveling solitary wave solutions for equation (4). It clearly indicates that under certain parametric conditions, equation (4) does have bounded kink-profile traveling wave solutions. Based on this result, in this section, a class of traveling wave solutions of the cBKDV equation is established by using a hyperbolic ansatz which is actually a combination of bell-profile waves and kink-profile waves of the form

$$u(x, t) = \sum_{i=1}^n (B_i \tanh^i [C_i(x - vt + x_0)] + D_i \operatorname{sech}^i [C_i(x - vt + x_0)]) + B_0, \quad (7)$$

where the  $B_i$ 's,  $C_i$ 's,  $D_i$ 's, ( $i = 1, \dots, n$ ),  $v$  and  $B_0$  are constants to be determined, and  $x_0$  is arbitrary.

After substitution of (7) into equation (6), we get

$$\begin{aligned}
& \sum_{i=1}^n \left\{ \begin{aligned} & i (-\operatorname{sech}[C_i \xi]^i + (1+i) \operatorname{sech}[C_i \xi]^{2+i} \sinh[zC_i]^2) C_i^2 D_i \\ & + B_i C_i^2 ((-1+i)i \operatorname{sech}[C_i \xi]^4 \tanh[C_i \xi]^{-2+i} - 2i \operatorname{sech}[C_i \xi]^2 \tanh[C_i \xi]^i) \end{aligned} \right\} \\
& + \frac{\mu \sum_{i=1}^n (-i \operatorname{sech}[C_i \xi]^{1+i} \sinh[C_i \xi] C_i D_i + i \operatorname{Sech}[C_i \xi]^2 B_i C_i \tanh[zC_i]^{-1+i})}{s} \\
& + \frac{\beta (\sum_{i=1}^n (B_i \tanh^i[C_i \xi] + D_i \operatorname{sech}^i[C_i \xi]) + B_0)^3}{3s} \\
& + \frac{\alpha (\sum_{i=1}^n (B_i \tanh^i[C_i \xi] + D_i \operatorname{Sech}^i[C_i \xi]) + B_0)^2}{2s} - \frac{v (\sum_{i=1}^n (B_i \tanh^i[C_i \xi] + D_i \operatorname{sech}^i[C_i \xi]) + B_0)}{s} = 0.
\end{aligned} \tag{8}$$

The difficulty for solving this equation lies in finding the values of the constants  $B_i$ ,  $C_i$ ,  $D_i$ ,  $B_0$  and  $v$  by using the over-determined algebraic equations. Following [5], after balancing the higher-order derivative term and the leading nonlinear term, we deduce  $n = 1$ . Then we replace  $\operatorname{sech}(C_1 \xi)$  by  $\frac{2}{e^{C_1 \xi} + e^{-C_1 \xi}}$ ,  $\sinh(C_1 \xi)$  by  $\frac{e^{C_1 \xi} - e^{-C_1 \xi}}{2}$ ,  $\tanh(C_1 \xi)$  by  $\frac{e^{C_1 \xi} - e^{-C_1 \xi}}{e^{C_1 \xi} + e^{-C_1 \xi}}$ , and multiply both sides by  $(e^{C_1 \xi} + e^{-C_1 \xi}) e^{C_1 \xi}$ , so equation (8) can be rewritten in the following form:

$$\sum_{k=0}^6 P_k(B_0, B_1, C_1, D_1, v) e^{k C_1 \xi} = 0, \tag{9}$$

where the  $P_k$  ( $k = 0, \dots, 6$ ), are polynomials of  $B_0$ ,  $B_1$ ,  $C_1$ ,  $D_1$  and  $v$ .

With the aid of mathematical softwares such as Mathematica, when  $n = 1$ , equating the coefficient of each term  $e^{k C_1 \xi}$  ( $k = 0, \dots, 6$ ) in equation (9) to zero, yields a

nonlinear algebraic system which contains seven equations as follows:

$$\begin{aligned}
P_0 &= \left( \begin{array}{l} -24vB_0 + 12\alpha B_0^2 - 8\beta B_0^3 + 24\mu B_1 C_1 - 24vD_1 + 24\alpha B_0 D_1 + 24\beta B_0^2 D_1 \\ - 24sC_1^2 D_1 + 12\alpha D_1^2 + 24\beta B_0 D_1^2 + 8\beta D_1^3 \end{array} \right) = 0, \\
P_1 &= \left( \begin{array}{l} -6vD_1 + 6\alpha B_0 D_1 + 6\beta B_0^2 D_1 - 6\alpha B_1 D_1 - 12\beta B_0 B_1 D_1 \\ + 6\beta B_1^2 D_1 + 6\mu C_1 D_1 + 6sC_1^2 D_1 \end{array} \right) = 0, \\
P_2 &= \left( \begin{array}{l} -9vB_0 + \frac{9\alpha B_0^2}{2} + 3\beta B_0^3 + 3vB_1 - 3\alpha B_0 B_1 - 3\beta B_0^2 B_1 - \frac{3\alpha B_1^2}{2} \\ - 3\beta B_0 B_1^2 + 3\beta B_1^3 + 12\mu B_1 C_1 + 24sB_1 C_1^2 + 6\alpha D_1^2 \\ + 12\beta B_0 D_1^2 - 12\beta B_1 D_1^2 \end{array} \right) = 0, \\
P_3 &= -12vD_1 + 12\alpha B_0 D_1 + 12\beta B_0^2 D_1 - 12\beta B_1^2 D_1 - 36sC_1^2 D_1 + 8\beta D_1^3 = 0, \\
P_4 &= \left( \begin{array}{l} -9vB_0 + \frac{9\alpha B_0^2}{2} + 3\beta B_0^3 - 3vB_1 + 3\alpha B_0 B_1 + 3\beta B_0^2 B_1 - \frac{3\alpha B_1^2}{2} \\ - 3\beta B_0 B_1^2 - 3\beta B_1^3 + 12\mu B_1 C_1 - 24sB_1 C_1^2 + 6\alpha D_1^2 + 12\beta B_0 D_1^2 \\ + 12\beta B_1 D_1^2 \end{array} \right) = 0, \\
P_5 &= \left( \begin{array}{l} -6vD_1 + 6\alpha B_0 D_1 + 6\beta B_0^2 D_1 + 6\alpha B_1 D_1 + 12\beta B_0 B_1 D_1 \\ + 6\beta B_1^2 D_1 - 6\mu C_1 D_1 + 6sC_1^2 D_1 \end{array} \right) = 0, \\
P_6 &= \left( \begin{array}{l} -3vB_0 + \frac{3\alpha B_0^2}{2} + \beta B_0^3 - 3vB_1 + 3\alpha B_0 B_1 + 3\beta B_0^2 B_1 + \frac{3\alpha B_1^2}{2} \\ + 3\beta B_0 B_1^2 + \beta B_1^3 \end{array} \right) = 0.
\end{aligned} \tag{10}$$

System (10) can be solved consistently by using Mathematica again.

For sake of simplicity, we use  $\varepsilon_1$ ,  $\varepsilon_2$ ,  $\varepsilon_3$  and  $\varepsilon$  to denote 1 or  $-1$ , and denote by  $\kappa$  the quantity:

$$\kappa = \varepsilon_1 \frac{\alpha}{2|\beta|} \sqrt{\frac{|\beta|}{6s}} - \varepsilon_2 \frac{\mu}{6s} \tag{11}$$

The sets of solutions are given by:

$$\left\{ \begin{array}{l} B_0 = -\frac{\alpha}{2\beta} - \varepsilon_3 \sqrt{\frac{6s}{|\beta|}} \frac{\mu}{6s} \\ B_1 = \varepsilon_3 \sqrt{\frac{6s}{|\beta|}} \kappa \\ C_1 = 2\kappa \\ D_1 = i\varepsilon \left( \frac{\alpha}{2|\beta|} - \varepsilon_3 \frac{\mu}{6s} \sqrt{\frac{6s}{|\beta|}} \right) \\ v = -\frac{\mu^2}{6s} - 2s \left[ \frac{\alpha}{2|\beta|} \sqrt{\frac{|\beta|}{6s}} - \varepsilon_3 \frac{\mu}{6s} \right]^2 - \frac{\alpha^2}{4\beta} \end{array} \right. \tag{12}$$

with the constraint:

$$\varepsilon_1 \varepsilon_2 \varepsilon_3 = 1 \tag{13}$$

or:

$$B_1 = D_1 = 0 \tag{14}$$

Note that the second set to the fourth set of solutions are not of much interest, since they only correspond to three trivial cases—the constant solution. Now we examine

the first set of solutions. It is interesting to notice that the nature of traveling wave solutions completely depends on the values of the parameters  $\alpha$ ,  $\beta$ ,  $s$ ,  $\mu$ . Moreover, we observe that

- i.* depending on the sign of  $\frac{\mu^2}{6s} + 2s \left[ \frac{\alpha}{2|\beta|} \sqrt{\frac{|\beta|}{6s}} - \varepsilon_3 \frac{\mu}{6s} \right]^2 - \frac{\alpha^2}{4\beta}$ , the traveling wave solution moves positively or negatively;
- ii.* the case of  $B_1 \neq 0$  corresponds to a kink-profile wave solution;
- iii.* since  $-s\beta > 0$ ,  $D_1$  is purely imaginary; equation (4) thus admits a complex traveling solitary wave solution.  
Due to the *tanh* function, the real part of the solution  $u$  has a kink-profile, while its imaginary part has a bell-profile (due to the *sech* function).

## 2.2 Parametric Study

In the following, we are going to show the influence of parameters  $\alpha$ ,  $\beta$ ,  $s$ ,  $\mu$  on the shape and velocity of traveling waves, and a couple of traveling waves corresponding to different sets of parameters are illustrated.

### 2.2.1 Shape of Traveling Waves

The variations of the coefficients  $B_1$  and  $D_1$  have crucial influence on the bell-profile and kink-profile of traveling solitary waves.

For this purpose, we consider the quotient of  $B_1^2$  and  $D_1^2$ :

$$\frac{B_1^2}{D_1^2} = - \frac{\left( \frac{\alpha}{2|\beta|} - \varepsilon_1 \varepsilon_2 \frac{\mu}{\sqrt{6s|\beta|}} \right)^2}{\left( \frac{\alpha}{2|\beta|} - \varepsilon_3 \frac{\mu}{\sqrt{6s|\beta|}} \right)^2} \quad (15)$$

Due to the constraint (13):

$$\varepsilon_3 = \varepsilon_1 \varepsilon_2 \quad (16)$$

It ensures:

$$B_1^2 = -D_1^2 \quad (17)$$

and, since  $D_1$  is pure imaginary:

$$|B_1| = |D_1| \quad (18)$$

which results in an equilibrium between the bell-profile and kink-profile of the solitary wave.

## 2.2.2 Velocity Analysis

Here we extend our attention to the wave velocity  $v$ . From the formula of  $v$  in the first set of solutions, we can see the rate of change of  $v$  (with negative option) with respect to  $\alpha$  and  $\mu$ , respectively:

$$\frac{\partial v}{\partial \alpha} = \frac{\sqrt{\frac{6|\beta|}{s}} \varepsilon_3 \mu + 6 \alpha}{18 |\beta|}$$

$$\frac{\partial v}{\partial \mu} = \frac{s \alpha \sqrt{\frac{6\beta}{s}} \varepsilon_3 - 8 |\beta| \mu}{18 s |\beta|}$$

Since  $\beta < 0$ , there exists critical points for only one of those derivatives. For example, if  $\varepsilon_3 = -1$ , denote:

$$\alpha_v = \mu \sqrt{\frac{|\beta|}{6s}}, \quad (19)$$

In this specific case, we can derive variational tables as follows directly

$\alpha$	0	$\alpha_v$	$+\infty$
$\frac{\partial v}{\partial \alpha}$		-	+
$v$	$-\frac{2\mu^2}{9s}$	$-\frac{\mu^2}{4s}$	$+\infty$

$\mu$	0	$+\infty$
$\frac{\partial v}{\partial \mu}$		-
$v$	$\frac{\alpha^2}{6 \beta }$	$-\infty$

Denote respectively  $\alpha_c$  the value of the parameter  $\alpha$  which satisfies  $\alpha_v < \alpha_c$ ,  $v(\alpha_c) = 0$ , and  $\mu_c$  the value of the parameter  $\mu$  which satisfies  $0 < \mu_c$ ,  $v(\mu_c) = 0$ . When  $\alpha$  varies in  $[\alpha_c, +\infty[$  or  $\mu$  varies in  $[0, \mu_c]$ , the wave will propagate with a positive velocity. When  $\alpha$  gets larger and larger alone, the wave will propagate with a big positive speed; but when  $\mu$  becomes larger and larger alone, the wave will propagate with a big negative speed.

Similarly, from the derivative of  $v$  with respect to  $\beta$  and  $s$

$$\frac{\partial v}{\partial |\beta|} = -\frac{\alpha \left( 6 \alpha + \sqrt{\frac{6|\beta|}{s}} \varepsilon_3 \mu \right)}{36 \beta^2}, \quad \frac{\partial v}{\partial s} = \frac{\mu \left( -\sqrt{6} \alpha \varepsilon_3 + 8 \mu \sqrt{\frac{|\beta|}{s}} \right)}{36 s^2 \sqrt{\frac{|\beta|}{s}}}$$

There exists critical points for only one of those derivatives. For example, if  $\varepsilon_3 = -1$ , denote:

$$\beta_v = -\frac{\alpha^2 s}{6 \mu^2} \quad (20)$$



We can find the following table immediately

$ \beta $	0	$ \beta_v $	$+\infty$
$\frac{\partial v}{\partial  \beta }$	-	0	+
$v$	$+\infty$	$-\frac{\mu^2}{4s}$	$-\frac{\mu^2}{9s}$

$s$	0	$+\infty$
$\frac{\partial v}{\partial s}$	-	
$v$	$-\infty$	$-\frac{\alpha^2}{4\beta}$

As  $\beta$  approaches to zero, the absolute value of the wave speed will increase and eventually blows up. Similar thing will occur when  $s$  approaches to zero, but the wave will propagate with a positive speed.

### 2.2.3 Numerical Example

Figure 1 presents the real and imaginary parts of the traveling solitary wave as functions of the space variable  $x$  and the time variable  $t$  for  $\alpha = 0.05$ ,  $\beta = -0.15$ ,  $s = 1$ ,  $\mu = 0.5$ . For this set of values:

$$\varepsilon_1 = -\varepsilon_2 = -\varepsilon_3 = 1 \quad (21)$$

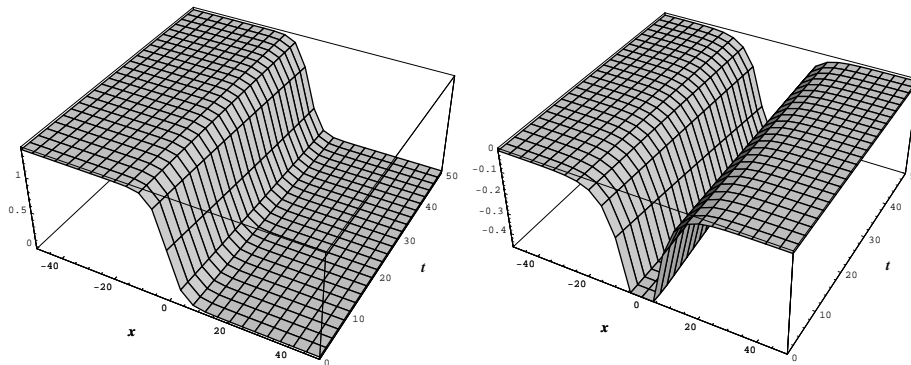

Figure 1: The real and imaginary parts of the traveling wave when  $\alpha = 0.05$ ,  $\beta = -0.15$ ,  $s = 1$  and  $\mu = 0.5$ .

The real part of the traveling wave presents a kink-profile, while the imaginary part presents a bell-profile, as it could be expected, since  $|B_1| = |D_1|$ ,  $D_1$  being purely imaginary.

Here we wish to clarify that the coefficients of the solutions in [5, pp.428-429] are incorrect. By comparison with the previous codes, we find that it is mainly due to Mathematica codes used for [5], in which a cubic term was missed while authors typed the algebraic system.

### 3 Discussion

In this work, by applying a hyperbolic ansatz, we obtain a class of new kink-profile traveling solitary wave solutions to the cBKdV equation (1), which indicates the coefficients of the solutions in a previous work [5] are incorrect. One of the advantages of this approach is that it is very straightforward to generate new solutions and easily carried out with the aid of mathematical softwares.

Although explicit forms of traveling solitary wave solutions are described herein and in the mentioned literature, as far as our knowledge goes, it is still unclear whether the cBKdV equation has any other type of bounded traveling solitary wave solutions. In the near future, we are going to use Lie group analysis as well as some other innovative methods to continue studying this challenging problem. Physical explanation for the solutions will be provided and the stability will be also analyzed as the parameters vary.

### References

- [1] Burgers J. M., Mathematical examples illustrating relations occurring in the theory of turbulent fluid motion, *Trans. Roy. Neth. Acad. Sci.* Amsterdam, 17 (1939) 1-53.
- [2] Korteweg D. J. and de Vries G., On the change of form of long waves advancing in a rectangular channel, and on a new type of long stationary waves, *Phil. Mag.* 39 (1895) 422-443.
- [3] Wadati M., The modified Korteweg-de Vries equation, *J. Phys. Soc. Japan*, 34 (1973) 1289-1296.
- [4] Wang M. L., Exact solutions for a compound KdV-Burgers equation, *Phys. Lett. A*, 213 (1996) 279-287.
- [5] Feng Z. and Chen G., Solitary Wave Solutions of the Compound Burgers-Korteweg-de Vries Equation, *Physica A*, 352 (2005) 419-435.
- [6] Feng, Z., A note on “Explicit exact solutions to the compound Burgers-Kortewegde Vries equation”, *Phys. Lett. A*, 312 (2003) 65-70.
- [7] Feng, Z., On explicit exact solutions to the compound Burgers-KdV equation, *Phys. Lett. A*, 293 (2002) 57-66.

- [8] Parkes E. J. and Duffy, B. R., Traveling solitary wave solutions to a compound KdV-Burgers equation, *Phys. Lett. A* 229 (1997) 217-220.
- [9] Parkes E. J., A note on solitary-wave solutions to compound KdVBurgers equations, *Phys. Lett. A* 317 (2003) 424-428.
- [10] Zhang W. G., Chang Q. S. and Jiang B. G., Explicit exact solitary-wave solutions for compound KdV-type and compound KdVBurgers-type equations with nonlinear terms of any order, *Chaos, Solitons & Fractals*, 13 (2002) 311-319.
- [11] Zhang W. G., Exact solutions of the Burgerscombined KdV mixed equation, *Acta Math. Sci.* 16 (1996) 241248.
- [12] Li B., Chen Y. and Zhang H. Q., Explicit exact solutions for new general two-dimensional KdV-type and two-dimensional KdVBurgers-type equations with nonlinear terms of any order, *J. Phys. A (Math. Gen.)* 35 (2002) 82538265.
- [13] Whitham G. B., *Linear and Nonlinear Wave*, Wiley-Interscience, New York, 1974.
- [14] Ablowitz M. J. and Segur H., *Solitons and the Inverse Scattering Transform*, SIAM, Philadelphia, 1981.
- [15] Dodd R. K., Eilbeck J. C., Gibbon J.D. and Morris H. C., *Solitons and Nonlinear Wave Equations*, London Academic Press, London, 1983.
- [16] Johnson R. S., *A Modern Introduction to the Mathematical Theory of Water Waves*, Cambridge University Press, Cambridge, 1997.
- [17] Ince E.L., *Ordinary Differential Equations*, Dover Publications, New York, 1956.
- [18] Zhang Z. F., Ding T.R., Huang W. Z. and Dong Z. X., *Qualitative Analysis of Nonlinear Differential Equations*, Science Press, Beijing, 1997.