



HAL
open science

Multi-scale modeling of follicular ovulation as a reachability problem

Nki Echenim, Frédérique Clément, Michel Sorine

► **To cite this version:**

Nki Echenim, Frédérique Clément, Michel Sorine. Multi-scale modeling of follicular ovulation as a reachability problem. 2006. hal-00086574v1

HAL Id: hal-00086574

<https://hal.science/hal-00086574v1>

Preprint submitted on 19 Jul 2006 (v1), last revised 5 Feb 2007 (v2)

HAL is a multi-disciplinary open access archive for the deposit and dissemination of scientific research documents, whether they are published or not. The documents may come from teaching and research institutions in France or abroad, or from public or private research centers.

L'archive ouverte pluridisciplinaire **HAL**, est destinée au dépôt et à la diffusion de documents scientifiques de niveau recherche, publiés ou non, émanant des établissements d'enseignement et de recherche français ou étrangers, des laboratoires publics ou privés.

Multi-scale modeling of follicular ovulation as a reachability problem

Nki Echenim [†] Frederique Clément [†] Michel Sorine [†]

Abstract During each ovarian cycle, only a definite number of follicles ovulate, while the others undergo a degeneration process called atresia. We have designed a multi-scale mathematical model where ovulation and atresia result from a hormonal controlled selection process. A 2D-conservation law describes the age and maturity structuration of the follicular cell population. In this paper, we focus on the operating mode of the control, through the study of the characteristics of the conservation law. We describe in particular the set of microscopic initial conditions leading to the macroscopic phenomenon of either ovulation or atresia, in the framework of backwards reachable sets theory.

Keywords : biomathematics, conservation laws, method of characteristics, control theory, backwards reachable sets.

1 Introduction

The development of ovarian follicles is a crucial process for reproduction in mammals, as its biological meaning is to free fertilizable oocyte(s) at the time of ovulation. A better understanding of follicular development is both a clinical and zootechnical challenge; it is required to improve the control of anovulatory infertility in women, as well as ovulation rate and ovarian cycle chronology in domestic species.

Within all the developing follicles, very few actually reach the ovulatory size; most of them undergo a degeneration process, known as atresia [1]. The ovulation rate (number of ovulatory follicles per cycle) results from an FSH (Follicle Stimulating Hormone)-dependent follicle selection process. FSH acts on the cells surrounding the oocyte, the granulosa cells, and controls both their commitment towards either proliferation, differentiation or apoptosis and their ability to secrete hormones such as estradiol. The whole estradiol output from the ovaries is responsible for exerting a negative feedback on FSH release. Following the subsequent fall in plasmatic FSH levels, most of the follicles undergo atresia and only the ovulatory ones survive in the FSH-poor environment.

We have proposed a mathematical model, using both multi-scale modeling and control theory concepts, to describe the follicle selection process [2]. For each follicle, the cell population dynamics is ruled by a conservation law with variable coefficients which describes the changes in age and maturity of the granulosa cell density. A control term, representing FSH signal, intervenes both in the velocity and loss terms of the conservation law. Two acting controls are distinguished: one is a local control, specific to each follicle (micro scale), and the other is a global control that results from the ovarian feedback (macro scale). Both ovulation triggering and follicular ovulation depend on the reaching of a target.

In this paper, we aim at using control theory to characterize follicular trajectories and the control laws leading to ovulation or atresia. The macroscopic phenomenon of follicular ovulation is considered as a reachability

[†]Unite de Recherche INRIA Rocquencourt, Domaine de Voluceau, Rocquencourt BP 105, 78153 Le Chesnay Cedex, FRANCE
tel: +33 1 39 63 57 41
fax: +33 1 39 63 57 86

problem for the microscopic variables of the characteristics system associated with the conservation law. The problem is enounced in details and solved in open-loop. Follicles are assumed to ovulate if their state variables, (age, maturity and cell density) reach a given target set. Backwards reachable sets theory is used to define the initial conditions compatible with latter ovulation, for a given control panel. In section 2, the conservation laws describing the model for follicle selection and their characteristics are presented. In section 3, the target corresponding to follicular ovulation is defined. Reachable sets theory is used to solve the corresponding control problem and simulation results are discussed. Section 4 is devoted to discussion and perspectives.

2 Follicle selection model

2.1 Conservation laws

For a given follicle, f , the cell density function, $\phi_f(a, \gamma, t)$, evolves with different velocities according to the cellular phase. Phases 1 and 2 correspond to the proliferation phases (respectively the G1 phase and the S to M phases), and phase 3 corresponds to the differentiation phase, after cells have exit the cell cycle (see Figure 1).

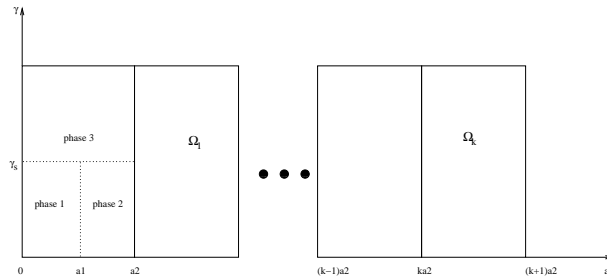

Figure 1: Cellular phases on the age-maturity plan. *The cell cycle consists of the cyclic phase 1-phase 2-phase 1 pathway. When it enters phase 1 from phase 2, a mother cell gives birth to two daughter cells. Cell differentiation corresponds to the flow from phase 1 into phase 3. a_2 is the cell cycle length.*

The variable t denotes time. The cell age a is a marker of progression within the cell cycle. The maturity marker γ is used to sort the cycling and non-cycling cells and to characterize the cell vulnerability to apoptosis.

In each cellular phase, both a global and a local control term, respectively U and u_f , act on the velocity and loss terms of the conservation law.

Let $\Omega_k = \{(a, \gamma) \in]ka_2, (k+1)a_2[\times]0, \infty)\}$ and $Q_k = \Omega_k \times]0, T[\ \forall k \in \mathbb{N}$. The domain Ω_k in the age-maturity plan is represented on Figure 1. On each Q_k , the generic form of the conservation law for the cell density ϕ_f^k is:

$$\frac{\partial \phi_f^k}{\partial t} + \frac{\partial g_f(u_f) \phi_f^k}{\partial a} + \frac{\partial h_f(\gamma, u_f) \phi_f^k}{\partial \gamma} = -\lambda(\gamma, U) \phi_f^k \quad (1)$$

The g_f and h_f functions are respectively the aging and maturation velocities, and λ is the loss term. Their

dynamics are discontinuous according to:

$$\begin{aligned}
\text{In phase 1: } \forall k \in \mathbb{N} \quad \forall (a, \gamma) &\in [ka_2, ka_2 + a_1[\times]0, \gamma_s[\\
g_f(u_f) &= \tau_{gf}(g_1 u_f + g_2) \\
h_f(\gamma, u_f) &= \tau_{hf}(-\gamma^2 + (c_1 \gamma + c_2)(1 - \exp(-u_f/\bar{u}))) \\
\lambda(\gamma, U) &= \Omega(\gamma)(1 - U) \quad \text{with } U \leq 1
\end{aligned} \tag{2}$$

$$\begin{aligned}
\text{In phase 2: } \forall k \in \mathbb{N} \quad \forall (a, \gamma) &\in [ka_2 + a_1, (k+1)a_2[\times]0, \gamma_s[\\
g_f(u_f) &= 1 \\
h_f(\gamma, u_f) &= 0 \\
\lambda(\gamma, U) &= 0
\end{aligned} \tag{3}$$

$$\begin{aligned}
\text{In phase 3: } \forall k \in \mathbb{N} \quad \forall (a, \gamma) &\in [0, \infty) \times [\gamma_s, \infty) \\
g_f(u_f) &= 1 \\
h_f(\gamma, u_f) &= \tau_{hf}(-\gamma^2 + (c_1 \gamma + c_2)(1 - \exp(-u_f/\bar{u}))) \\
\lambda(\gamma, U) &= \Omega(\gamma)(1 - U)
\end{aligned} \tag{4}$$

Where $\Omega(\gamma) = K \exp\left(-\left(\frac{\gamma - \gamma_s}{\bar{\gamma}}\right)^2\right)$, and all parameters are real positive numbers defined in Table 1.

In phase 1, both the aging and maturation velocities are controlled. Phase 2 is an uncontrolled phase corresponding to a delay in age ($a_2 - a_1$) in the system dynamics. In phase 3, only the maturation velocity is controlled. Cells are sensitive to death due to apoptosis in phase 1 and phase 3 [2].

The boundary conditions between each domain Q_k are defined by (we will justify later the existence of the trace values used here and the well-posedness of this model):

$$\begin{aligned}
\text{for } k = 0 \\
\phi_f^0(0, \gamma, t) &= 0 \\
\phi_f^0(a, 0, t) &= 0 \\
\text{for } k \in \mathbb{N}^* \\
\phi_f^k(ka_2, \gamma, t) &= \phi_f^{k-1}(ka_2, \gamma, t) \quad \text{for } (\gamma, t) \in [\gamma_s, \infty) \times]0, T[\\
\tau_{gf}(g_1 u_f + g_2) \phi_f^k(ka_2, \gamma, t) &= 2\phi_f^{k-1}(ka_2, \gamma, t) \quad \text{for } (\gamma, t) \in [0, \gamma_s[\times]0, T[\\
\phi_f^k(a, 0, t) &= 0
\end{aligned}$$

The initial conditions for each follicle f on each domain Q_k are given by:

$$\phi_f^k(a, \gamma, 0) = \phi_{f0}(a, \gamma)|_{\Omega_k}$$

We define the cell density in a follicle, ϕ_f , as

$$\phi_f = \phi_f^k \text{ on } Q_k, k \in \mathbb{N}$$

The feedback exerted by the ovaries on the secretion of the hormonal control FSH defines a closed-loop system (cf. Figure 2). The global control U can be interpreted as the plasmatic FSH levels. The local control u_f is a proportion of U , which is individually modulated for each follicle.

Define the maturity operator M as:

$$M(\varphi)(t) = \int_0^{\gamma_{max}} \int_0^{a_{max}} \gamma \varphi(a, \gamma, t) da d\gamma \tag{5}$$

Main functions and parameters	Definition	Nominal value
$S[M(\sum_f \phi_f)]$	Global feedback control	
U_s	minimal plasmatic FSH value	0.5
c	slope parameter of the sigmoid function	0.1
m	abscissa of the inflexion point of the sigmoid function	50
τ	delay for FSH to reach the ovaries from the pituitary gland	0.01
$b_f[M(\phi_f)]$	Local feedback gain	
b_1	basal level	0.054
b_2	exponential rate	0.3
b_3	scaling parameter	27
τ_f	delay for follicular maturity to modify local vascularization	0.01
$g_f(u_f)$	Aging velocity	
τ_{gf}	time scale parameter	1
g_1	origin ordinate in phase 1	0.5
g_2	slope parameter in phase 1	0.5
$h_f(\gamma, u_f)$	Maturation velocity	
τ_{hf}	time scale parameter	0.07
c_1	slope parameter	11.892
c_2	origin ordinate	2.288
\bar{u}	scaling parameter	0.133
$\Omega(\gamma)$	Global feedback gain	
K	amplification constant	3
$\bar{\gamma}$	scaling parameter	0.2
a_1	cellular age at the end of phase 1	1
a_2	cellular age at the end of phase 2	2
γ_s	maturity threshold for cell cycle exit	3
M_s	ovarian threshold for ovulation triggering	75
M_{s1}	follicular threshold for ovulation ability	40

Table 1: Model functions and parameters

This operator computes the global maturities $M(\phi_f)$ on the follicular scale, and $M(\sum_f \phi_f)$ on the ovarian scale, which enter into the dynamics of the control terms:

$$\begin{aligned}
U(t) &= S(M(\sum_f \phi_f)(t - \tau)) + U_0(t) \\
&= U_s + \frac{1 - U_s}{1 + \exp[c(M(\sum_f \phi_f)(t - \tau) - m)]} + U_0(t) \\
u_f &= b_f(M(\phi_f)(t - \tau_f))U \\
\text{where } b_f(M(\phi_f)) &= b_1 + \frac{1 - b_1}{1 + \exp(b_2(b_3 - M(\phi_f)))}
\end{aligned} \tag{6}$$

S is a decreasing sigmoid function that accounts for the ovarian negative feedback on FSH, $U_0(t)$ is a potential exogenous entry, and τ is a delay introduced to take into account the time needed for FSH signal to reach the ovaries; u_f increases (b_f is an increasing sigmoid function) with the delayed maturity of follicle f , up to its reaching FSH plasmatic values. τ_f is such as $\tau_f \leq \tau$.

Ovulation is triggered when estradiol levels reach a threshold value M_s . As estradiol secretion is related to

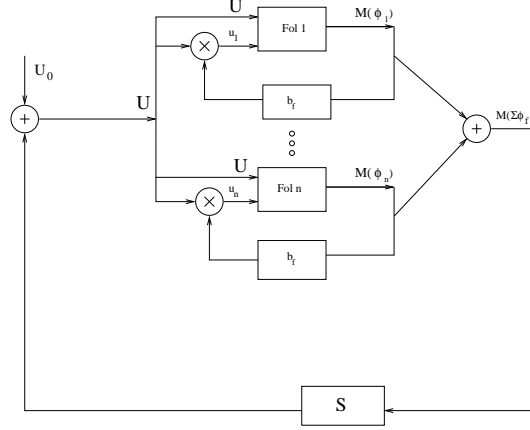

Figure 2: Ovarian system: the multi-scale model in closed-loop. *The global feedback control U is modulated on the follicle scale (Fol i), by the follicular maturity, $M(\phi_i)$, to define the local control u_{fi} .*

maturity, (see [2]), ovulation time is defined as:

$$T \text{ such as } M\left(\sum_f \phi_f\right)(T) = M_s \quad (7)$$

The follicles are then sorted according to their individual maturity. The ovulatory follicles are those whose maturity at time T has overpassed a threshold M_{s1} such as $M_{s1} \leq M_s$. The ovulation rate is computed as:

$$N = \text{Card}\{f | M(\phi_f)(T) \geq M_{s1}\}$$

Figure 3 shows the repartition, on the age-maturity domain, of the cell density of an ovulatory and an atretic follicle at ovulation time. The cell cycle is implemented on a periodic domain, where the age a is reset after the cells go through mitosis. The granulosa cell repartition in the ovulatory follicle is characterized by a roughly older age range, and a higher maturity and cell density ranges than in the atretic follicle.

2.2 Wellposedness of the model

We first consider Eq.(1) in open-loop, so that the control terms u_f and U are given functions of time. We can thus express the velocities and loss term as $g_f(t)$, $h_f(\gamma, t)$ and $\lambda(\gamma, t)$. In this case, we show below that there exists a unique solution to Eq.(1) on the whole domain.

We use a change of variables to transform Eq.(1) into a conservation equation without a loss term.

Let $\phi_f^k = \tilde{\phi}_f^k \exp(l(\gamma, t))$ defined on Q_k . Let ∂Q_k denote the boundary of the domain Q_k .

Let $l(\gamma, t)$ such as

$$\begin{aligned} \frac{\partial l(\gamma, t)}{\partial t} + h_f(\gamma, t) \frac{\partial l(\gamma, t)}{\partial \gamma} &= -\lambda(\gamma, t) \\ l(0, t) = l(\gamma, 0) &= 0 \end{aligned} \quad (8)$$

We have $h_f \in L^\infty(Q_k)$ (see paragraph 3.2.1), $\text{div}(h_f) \in L^\infty(Q_k)$ and $\lambda \in L^2(Q_k)$. Then there exists, according to [3], a unique solution $l(\gamma, t)$ in $L^2(Q_k)$ and its trace is well-defined in $L^2(\partial Q_k)$. Now $\tilde{\phi}_f^k$ verifies

$$\frac{\partial \tilde{\phi}_f^k}{\partial t} + \text{div}(v_f \tilde{\phi}_f^k) = 0 \quad (9)$$

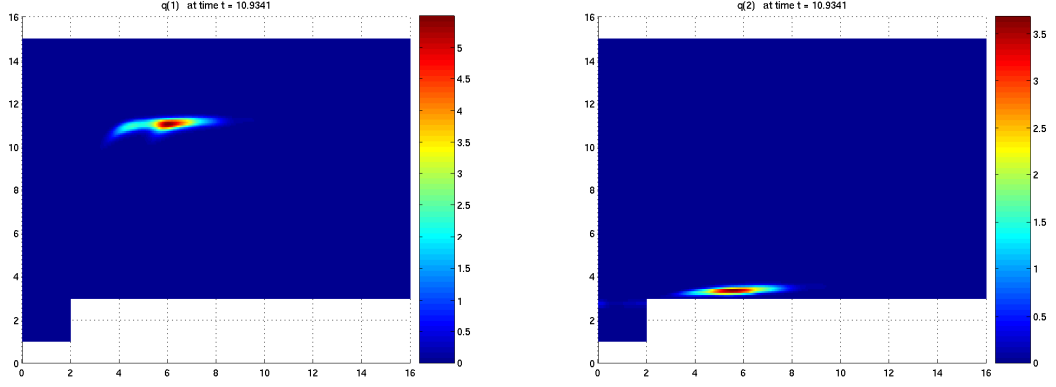

Figure 3: Repartition of the cell density of an ovulatory follicle (left) and an atretic follicle (right). The horizontal axis represents the cell age, the vertical axis the cell maturity, and the colorbar indicates the cell density value.

where v_f is the velocity vector: $v_f = \begin{pmatrix} g_f(t) \\ h_f(\gamma, t) \end{pmatrix}$.

We notice that $g_f(t) > 0$ for $a = ka_2$ and $h_f(\gamma, t) > 0$ for $\gamma = 0$.

We note $\partial\Omega_k^a = \{(a, \gamma) \mid a = ka_2\}$. The inward boundary for Eq.(9) is $\partial Q_k^a = \partial\Omega_k^a \cup \{(a, \gamma) \mid \gamma = 0\} \times]0, T[$, the boundary conditions are $\tilde{\phi}_f^k|_{\partial\Omega_k^a} = \Gamma_k^-(\gamma, t)$ and $\tilde{\phi}_f^k(a, 0, t) = 0$ and the initial condition is $\tilde{\phi}_f^k|_{Q_k} = \phi_{f0}|_{Q_k}$. As $v_f \in L^\infty(Q_k)^2$ and $\text{div}(v_f) \in L^\infty(Q_k)$, according to [3], there exists a unique solution $\tilde{\phi}_f^k \in L^2(Q_k)$ and its trace is well-defined in $L^2(\partial Q_{k+1}^a)$ as soon as $\Gamma_k^- \in L^2(\partial Q_k^a)$ and $\phi_{f0} \in L^2(Q_k)$.

Finally we can solve the following problem P_k :

$$\begin{cases} \frac{\partial \phi_f^k}{\partial t} + \frac{\partial g_f(t) \phi_f^k}{\partial a} + \frac{\partial h_f(\gamma, t) \phi_f^k}{\partial \gamma} = -\lambda(\gamma, t) \phi_f^k \\ \phi_f^k|_{\partial Q_k^a} = \Gamma_k^-(\gamma, t) \\ \phi_f^k(a, 0, t) = 0 \\ \phi_f^k(a, \gamma, 0) = \phi_{f0}|_{\Omega_k} \end{cases}$$

which allows to compute ϕ_f^k on Q_k and $\Gamma_k^+ = \phi_f^k|_{\partial Q_{k+1}^a}$.

Now we can successively solve the P_k problems, where:

for $k = 0$, $\Gamma_k^-(\gamma, t) = 0 \in L^2(Q_0)$;

for $k > 0$, $\Gamma_k^-(\gamma, t) \in L^2(Q_k)$ defined by:

$$\begin{cases} \Gamma_k^-(\gamma, t) = \frac{2}{\tau_{gf}(g_1 u_f + g_2)} \Gamma_{k-1}^+(\gamma, t) & (\gamma, t) \in [0, \gamma_s[\times]0, T[\\ \Gamma_k^-(\gamma, t) = \Gamma_{k-1}^+(\gamma, t) & (\gamma, t) \in [\gamma_s, \infty[\times]0, T[\end{cases}$$

It is easy to see that ϕ_f defined on the whole domain by $\phi_f = \phi_f^k$ on $L^2(Q_k) \forall k \in \mathbb{N}$ is unique.

The closed-loop model can be considered as a succession of open-loop equations solved on the time intervals $[0, \tau_f[, [\tau_f, 2\tau_f[, \dots$. On each time interval $[i\tau_f, (i+1)\tau_f[, \forall i \in \mathbb{N}$, the control terms, which close the loop (see Eq.(6)), are already defined by the dynamics of the system on the $[(i-1)\tau_f, i\tau_f[$ time interval, so that we deal with an open-loop problem. We can thus build the solution of the closed-loop problem and for the whole time interval considered, so that the closed-loop problem is also wellposed.

Remark that the stability of this closed-loop control is an open question.

2.3 Characteristic equations

The model deals with controlled partial differential equations. Up to now, no convincing control strategy for such equations is available from the literature. To tackle the control problems, we focus on the actions of the control terms on the characteristics of the conservation laws.

We now deal with the following ordinary differential equations [4]:

$$\begin{cases} \dot{a}_c = g_f(u_f) \\ \dot{\gamma}_c = h_f(\gamma_c, u_f) \\ \dot{\phi}_{fc} = - \left(\lambda(\gamma_c, U) + \frac{\partial h_f(\gamma_c, u_f)}{\partial \gamma_c} \right) \phi_{fc} \end{cases} \quad c = 1 \dots n \quad (10)$$

where g_f , h_f and λ are defined in Eqs.(2,3,4).

The local control u_f acts on the position of the characteristics on the (a_c, γ_c) spatial domain at a given time, and U on the loss term λ .

The transfer conditions between the cellular phases are continuous on a_c and γ_c and discontinuous on ϕ_{fc} . For the transfer between phase 1 and phase 2, the flux continuity condition gives:

- for T_i such as: $\forall k \in \mathbb{N} \quad a_c(T_i) = a_1 + ka_2 \quad 0 \leq \gamma_c(T_i) \leq \gamma_s$

$$\phi_{fc}(T_i^+) = \tau_{gf}(g_1 u_f(T_i^-) + g_2) \phi_{fc}(T_i^-) \quad (11)$$

For the transfer between phase 2 and phase 1, after mitosis, the flux doubling condition gives:

- for T_i such as: $\forall k \in \mathbb{N} \quad a_c(T_i) = ka_2 \quad 0 \leq \gamma_c(T_i) \leq \gamma_s$

$$\tau_{gf}(g_1 u_f(T_i^+) + g_2) \phi_{fc}(T_i^+) = 2 \phi_{fc}(T_i^-) \quad (12)$$

Ovulatory follicles are distinguished from the atretic ones by their characteristic curves reaching a given zone of the $(a_c, \gamma_c, \phi_{fc})$ space at a given time, as we can see on Figure 3. In the next section, we study the control terms that lead the characteristic curves into the target for ovulation or for atresia. We study the control problem in open-loop and for physiological coherence, take the constraint $u_f \leq U$ into account.

3 Backwards reachable sets

3.1 Link with Hamilton-Jacobi-Bellman equations

We assume that a follicle ovulates (resp. undergoes atresia) at time T if:

$\forall c = 1 \dots n, (a_c(T), \gamma_c(T), \phi_{fc}(T)) \in \mathcal{M}_o$ (resp. $\in \mathcal{M}_a$) where \mathcal{M}_o represents the target for ovulation and \mathcal{M}_a the target for atresia. We focus here on the backwards problem, and seek the backwards reachable set of \mathcal{M}_o (resp. \mathcal{M}_a), i.e. the states from which it is possible to reach \mathcal{M}_o (resp. \mathcal{M}_a), given admissible controls U and u_f . On a physiological viewpoint, it corresponds to the initial conditions compatible with ovulation (resp. atresia), subject to correct control laws amongst the set of admissible controls.

Such backwards reachability problems can be solved in the framework of optimal control theory. Let us consider the nonlinear continuous dynamics:

$$\begin{cases} \dot{x} = f(t, x, u) \\ x \in \mathbb{R}^n \\ u \in U \subset \mathbb{R}^m \end{cases} \quad (13)$$

For a Lipschitz continuous function f , there is a unique solution to the initial-value problem for any $u(t)$. Given a target set $\mathcal{M} \in \mathbb{R}^n$, the backwards reachable set $W[\tau] = W(\tau, t_1, \mathcal{M})$ from time τ to t_1 is the set of states $x \in \mathbb{R}^n$ for each of which there exists a control $u(t)$ that steers system (13) from the state $x(\tau) = x$ to $x(t_1) \in \mathcal{M}$ [5].

Let:

$$V(\tau, x) = \min_u \{d^2(x(t_1), \mathcal{M}) | x(\tau) = x\} \quad (14)$$

where $d^2(x, X) = \min\{(x - z, x - z) | z \in X\}$ is the square of the distance function $d(x, X)$ from point x to set X .

Then the following property is true:

$$W(\tau, t_1, \mathcal{M}) = \{x | V(\tau, x) = 0\} \quad (15)$$

The idea is to find among all possible controls the one (or those) that can steer the state x into the target set \mathcal{M} at time t_1 , thus to minimize the distance function $d^2(x(t_1), \mathcal{M})$ according to the control u . Each state such as $d^2(x(t_1), \mathcal{M}) = 0$ is in the target \mathcal{M} at time t_1 .

Eq.(14) corresponds to an optimal control problem, which can be solved by the ‘‘backwards’’ Hamilton-Jacobi-Bellman (HJB) equation [6]:

$$V_t + \min_u \{V_x \cdot f(t, x, u)\} = 0 \quad (16)$$

$$V(t_1, x) = d^2(x(t_1), \mathcal{M}) \quad (17)$$

where $\min_u \{V_x \cdot f(t, x, u)\}$ is the Hamiltonian.

The backwards reachable set of system (13) at time τ can thus be computed by solving Eq.(16) with the final condition (17), and then finding the zero-level set of the solution $V(\tau, x)$ to identify the states that verify Eq.(15).

3.2 Application to granulosa cells

3.2.1 Solution uniqueness

We represent each follicle by n characteristic curves, with three state variables: an age, a maturity and a cell density, so that the state dimension is $3 \times n$. System (13) can be identified with

$$x = (a_1(t), \dots, a_n(t); \gamma_1(t), \dots, \gamma_n(t); \phi_{f1}(t), \dots, \phi_{fn}(t))^T$$

and for each cellular phase $i = 1, 2, 3$, the dynamics f_i are:

$$f_i = \begin{pmatrix} g_f(u_f) \\ \vdots \\ g_f(u_f) \\ h_f(\gamma_1, u_f) \\ \vdots \\ h_f(\gamma_n, u_f) \\ K(\gamma_1, u_f, U)\phi_{f1} \\ \vdots \\ K(\gamma_n, u_f, U)\phi_{fn} \end{pmatrix} \quad (18)$$

where the g_f and h_f functions are defined in Eqs.(2,3,4) and $K(\gamma_c, u_f, U)$ is defined by

$$\forall k \in \mathbb{N} \quad \forall (a_c, \gamma_c) \in [ka_2, ka_2 + a_1] \times [0, \gamma_s[\cup [0, \infty) \times [\gamma_s, \infty)$$

$$K(\gamma_c, u_f, U) = - \left(\lambda(\gamma_c, U) + \frac{\partial h_f(\gamma_c, u_f)}{\partial \gamma_c} \right)$$

$$\forall k \in \mathbb{N} \quad \forall (a_c, \gamma_c) \in [ka_2 + a_1, (k+1)a_2] \times [0, \gamma_s[$$

$$K(\gamma_c, u_f, U) = \ln(2)\phi_{fc} \quad (19)$$

$$(20)$$

In phase 1 and phase 3, $K(\gamma_c, u_f, U)$ verifies $\dot{\phi}_{fc} = K(\gamma_c, u_f, U)\phi_{fc}$ (see Eq.(10)). It differs from the expression given in phase 2, as we have regularized the ϕ_{fc} variable, to avoid the jumps (11) and (12) at the transitions between the cellular phases. The details of the regularization leading to those dynamics are given in Appendix A.

According to physiological knowledge, we can consider that there exists a maximal age, a_{max} , beyond which all cells become senescent and die. This assumption introduces the notion of a maximal life time T_{max} such as $a(T_{max}) = a_{max}$ (T_{max} exists because $\dot{a} > g_2 > 0$). Hence, there is also a maximal maturity γ_{max} and a maximal cell density ϕ_{fmax} attainable for $t \in [0, T_{max}]$. As all variables are bounded, the norm of the Jacobian matrix associated to f_i also is, so all f_i are Lipschitz continuous and there is a unique solution $x(t)$ per phase.

3.2.2 Hamiltonian in each cellular phase

The HJB equations that characterize the backwards reachable sets are obtained once the Hamiltonians in each phase have been minimized according to the control terms U and u_f . Let us assume that U is bounded: $U \in [U_{min}, U_{max}]$. This assumption is natural as U represents the plasmatic level of FSH. Then the multiplicative form of u_f (Eq.(6)) implies that u_f varies in the same interval, so $u = \{U, u_f\} \in [U_{min}, U_{max}]$ and that $u_f \leq U$.

For each cellular phase we solve an equation of the form

$$\begin{aligned} V_t + H_{f_i} &= 0 \\ V(t_1, x) &= d^2(x(t_1, \mathcal{M})) \end{aligned} \quad (21)$$

where \mathcal{M} is the target set, $H_{f_i} = \min_u \{(p^T \cdot f_i(t, x, u))\}$, and $p = D_x V = (p_{a_1}, \dots, p_{a_n}, p_{\gamma_1}, \dots, p_{\gamma_n}, p_{\phi_{f_1}}, \dots, p_{\phi_{f_n}})^T$.

We first minimize the Hamiltonian as if U and u_f were independent, and then study the situations where the constraints $U_{min} \leq u_f \leq U \leq U_{max}$ are not respected.

Phase1

In phase 1, the Hamiltonian is:

$$\begin{aligned} H_{f_1} &= \min_u \{(p^T \cdot f_1(t, x, u))\} \\ p^T \cdot f_1(t, x, u) &= \tau_{gf} g_2 \sum_{c=1}^n p_{ac} + \tau_{hf} \left[\sum_{c=1}^n (-\gamma_c^2 + (c_1 \gamma_c + c_2)) p_{\gamma_c} \right] \\ &\quad - \sum_{c=1}^n \Omega(\gamma_c) \phi_{fc} p_{\phi_{fc}} + 2\tau_{hf} \sum_{c=1}^n \gamma_c \phi_{fc} p_{\phi_{fc}} - \tau_{hf} c_1 \sum_{c=1}^n \phi_{fc} p_{\phi_{fc}} \\ &\quad + u_f (\tau_{gf} g_1 \sum_{c=1}^n p_{ac}) - \exp(-u_f / \bar{u}) \left[\tau_{hf} \sum_{c=1}^n (c_1 \gamma_c + c_2) p_{\gamma_c} - \tau_{hf} c_1 \sum_{c=1}^n \phi_{fc} p_{\phi_{fc}} \right] \\ &\quad + U \left(\sum_{c=1}^n \Omega(\gamma_c) \phi_{fc} p_{\phi_{fc}} \right) \end{aligned}$$

This expression can be split into three type of terms : those that do not depend on any control term, those that depend on the control U and those that depend on u_f .

According to U , the expression to minimize has the form:

$$\begin{aligned} C &\times U \\ \text{where } C &= \left(\sum_{c=1}^n \Omega(\gamma_c) \phi_{fc} p_{\phi_{fc}} \right) \end{aligned} \quad (22)$$

If $C > 0$ then H_{f1} is minimized for $U = U_{min}$ else for $U = U_{max}$.

According to u_f , the expression to minimize has the form: $M(u_f) = -A \left[\exp\left(\frac{-u_f}{u}\right) \right] + Bu_f$ with

$$\begin{aligned} A &= \tau_{hf} \sum_{c=1}^n (c_1 \gamma_c + c_2) p_{\gamma_c} - \tau_{hf} c_1 \sum_{c=1}^n \phi_{fc} p_{\phi_{fc}} \\ B &= \tau_{gf} g_2 \sum_{c=1}^n p_{ac} \end{aligned} \quad (23)$$

The minimization of $M(u_f)$ depends on the sign of A and B . Figure 4 shows the variations of $M(u_f)$ for the four possible combinations.

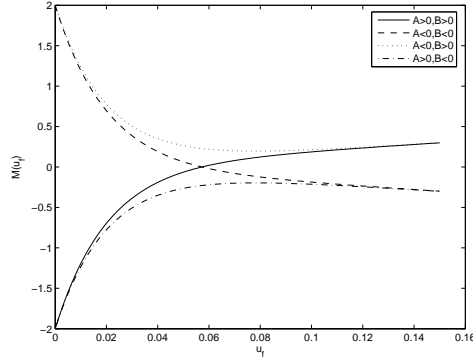

Figure 4: Variations of $M(u_f)$ according to the sign of A and B ($A = \pm 2$ and $B = \pm 2$).

The study of the variations of $M(u_f)$ results in the following minimization:

- . if $A > 0$ and $B \geq 0$ or $A \geq 0$ and $B > 0$ then $M(u_f)$ increases so that $u_f = U_{min}$.
- . if $A < 0$ and $B \leq 0$ or $A \leq 0$ and $B < 0$ then $M(u_f)$ decreases so that $u_f = U_{max}$.
- . if $A < 0$ and $B > 0$, $M(u_f)$ has a global minimum in $u_{fmin} \equiv -\bar{u} \ln \left[\frac{-B\bar{u}}{A} \right]$
 - if $u_{fmin} \in [U_{min}, U_{max}]$, then $u_f = u_{fmin}$,
 - else if $u_{fmin} \leq U_{min}$ then $u_f = U_{min}$,
 - else if $u_{fmin} > U_{max}$ then $u_f = U_{max}$.
- . if $A > 0$ and $B < 0$, $M(u_f)$ has a global maximum in u_{fmin} .
 - if $u_{fmin} \in [U_{min}, U_{max}]$,
 - then if $M(U_{min}) \leq M(U_{max})$ then $u_f = U_{min}$
 - else if $M(U_{min}) \geq M(U_{max})$ then $u_f = U_{max}$
 - else if $u_{fmin} \leq U_{min}$ then $u_f = U_{max}$,
 - else if $u_{fmin} > U_{max}$ then $u_f = U_{min}$.

When $U = U_{max}$ all constraints are automatically respected.

When $U = U_{min}$, and $u_f > U_{min}$ the constraint $u_f \leq U$ is transgressed. Such a case occurs when

$$C > 0, A < 0 \text{ and } B \leq 0 \quad (24)$$

and may occur when

$$C > 0, A < 0 \text{ and } B > 0 \quad (25)$$

$$C > 0, A > 0 \text{ and } B < 0 \quad (26)$$

For sake of concision, the results detailing the constrained minimization in those cases are given in Appendix B.

In case (24)

$$\begin{aligned} \text{if } B + C > -\frac{A}{\bar{u}} \exp\left(\frac{-U_{min}}{\bar{u}}\right) \text{ then } u_f = U = U_{min} \\ \text{if } B + C < -\frac{A}{\bar{u}} \exp\left(\frac{-U_{max}}{\bar{u}}\right) \text{ then } u_f = U = U_{max} \\ \text{if } -\frac{A}{\bar{u}} \exp\left(\frac{-U_{max}}{\bar{u}}\right) \leq B + C \leq -\frac{A}{\bar{u}} \exp\left(\frac{-U_{min}}{\bar{u}}\right) \text{ then } u_f = U = -\bar{u} \ln\left(-\frac{(B+C)\bar{u}}{A}\right) \end{aligned}$$

In cases (25) and (26), we use the following control law:

$$\begin{aligned} \text{if } B + C > -\frac{A}{\bar{u}} \exp\left(\frac{-U_{min}}{\bar{u}}\right) \text{ then } u_f = U = U_{min} \\ \text{if } \begin{cases} B + C \leq -\frac{A}{\bar{u}} \exp\left(\frac{-U_{max}}{\bar{u}}\right) \\ B < -\frac{A}{\bar{u}} \exp\left(\frac{-U_{max}}{\bar{u}}\right) \end{cases} \text{ then } u_f = U = U_{max} \\ \text{if } \begin{cases} B + C \leq -\frac{A}{\bar{u}} \exp\left(\frac{-U_{max}}{\bar{u}}\right) \\ B \geq -\frac{A}{\bar{u}} \exp\left(\frac{-U_{max}}{\bar{u}}\right) \end{cases} \text{ then } u_f = -\bar{u} \ln\left(-\frac{(B+C)\bar{u}}{A}\right) \end{aligned}$$

Phase 2

This phase is not controlled so that the expression of its Hamiltonian is found immediately:

$$H_{f2} = \sum_{c=1}^n p_{ac} + \ln(2) \sum_{c=1}^n p_{\phi_{fc}} \phi_{fc}$$

Phase 3

The expression of the Hamiltonian in phase 3 is given by:

$$\begin{aligned} H_{f3} &= \min_u \{ (p^T \cdot f_3(t, x, u)) \} \\ p^T \cdot f_3(t, x, u) &= \sum_{c=1}^n p_{ac} + \tau_{hf} \left[\sum_{c=1}^n (-\gamma_c^2 + (c_1 \gamma_c + c_2)) p_{\gamma_c} \right] \\ &\quad - \sum_{c=1}^n \Omega(\gamma_c) \phi_{fc} p_{\phi_{fc}} + 2\tau_{hf} \sum_{c=1}^n \gamma_c \phi_{fc} p_{\phi_{fc}} - \tau_{hf} c_1 \sum_{c=1}^n \phi_{fc} p_{\phi_{fc}} \\ &\quad - \exp(-u_f/\bar{u}) \left[\tau_{hf} \sum_{c=1}^n (c_1 \gamma_c + c_2) p_{\gamma_c} - \tau_{hf} c_1 \sum_{c=1}^n \phi_{fc} p_{\phi_{fc}} \right] \\ &\quad + U \left(\sum_{c=1}^n \Omega(\gamma_c) \phi_{fc} p_{\phi_{fc}} \right) \end{aligned}$$

Reminding the definition of C in Eq.(22) and A in Eq.(23), we obtain as control law: according to U , if $C > 0$ then H_{f3} is minimized for $U = U_{min}$ else for $U = U_{max}$.

According to u_f , the expression of H_{f3} is minimized for $u_f = U_{min}$ if $A \geq 0$ and for $u_f = U_{max}$ if $A \leq 0$.

When

$$C > 0 \text{ and } A < 0 \quad (27)$$

the constraint $u_f \leq U$ is not respected. The control law has to be amended according to (see Appendix B):

$$\begin{aligned} \text{if } -\frac{A}{\bar{u}} \exp\left(\frac{-U_{min}}{\bar{u}}\right) < C \text{ then } u_f &= U = U_{min} \\ \text{if } -\frac{A}{\bar{u}} \exp\left(\frac{-U_{min}}{\bar{u}}\right) \geq C \text{ then } u_f &= U = U_{max} \end{aligned}$$

This analytical minimization enables to write the expression of the Hamiltonians in each cellular phase.

3.3 Numerical results

3.3.1 Implementation: level set methods

Two main approaches are used to find reachable sets: the Eulerian approach approximates the solution values on a fixed grid, whereas the Lagrangian approach tracks the trajectories of the dynamics. In case of backwards reachable sets, Eulerian methods are the most appropriate, as they take into account the presence of shocks in the HJB equations [7].

Amongst the various Eulerian methods available to compute the exact reachable sets, we used “level set methods” to solve Eq.(16). They enable to simulate the motion of dynamic surfaces, such as the zero-level set of HJB equations [8], with a very high accuracy (about a tenth of the spacing between the grid points [7]).

Such level set algorithms are implemented in the “Toolbox of Level Set Methods”¹, which can be used to solve, among others, equations of the form:

$$\begin{aligned} D_t V(x, t) + H(x, D_x V) &= 0 \\ \text{with the constraints } D_t V(x, t) &\geq 0 \text{ or } V(x, t) \geq \tilde{V}(x, t) \end{aligned}$$

The time derivative, $D_t V$, is approximated by a Runge-Kutta scheme, with customizable accuracy. The spatial derivative, $D_x V$, is approximated with an upwind finite difference scheme. The Hamiltonian, $H(x, p)$, is approximated with a Lax-Friedrichs scheme:

$$\hat{H}(x, p^+, p^-) \equiv H\left(x, \frac{p^+ + p^-}{2}\right) - \frac{1}{2}\alpha^T(p^+ - p^-)$$

where p^+ and p^- are respectively the right and left approximations of p , and α is an artificial dissipation coefficient added to avoid oscillations in the solution.

Although the toolbox is designed for solving initial value problems, it is possible, in case of autonomous systems, to solve final value problems by multiplying f in system (13) by (-1) [8].

3.3.2 Simulation results

The initial problem is a $3 \times n$ dimensional problem, where n is the number of characteristics considered. This problem is not tractable from a numerical ground. Indeed, for $n \geq 2$ and a correct number of grid points in each dimension ($\simeq 100$) we cope with too many points (100^{3n}), and face memory errors. We

¹<http://www.cs.ubc.ca/~mitchell/ToolboxLS/>

thus computed the backwards reachable sets for one characteristic, $(a_1, \gamma_1, \phi_{f1})$, corresponding to either an average ovulatory or atretic trajectory. Moreover the constrained optimization analytically performed asks for a much more refined grid than in the not constrained case, so that the simulation results are obtained for the latter situation.

In the case of ovulatory follicles, the boundaries of the target set \mathcal{M}_o are chosen to coincide with the ranges of age, maturity, and cell density reached by the characteristics of an ovulatory follicle at ovulation time ($t = 11$), (see Figure 3, left).

The target set \mathcal{M}_o for ovulation is thus defined as:

$$\mathcal{M}_o = \{(a_1, \gamma_1, \phi_{f1}) \in [10, 12] \times [10, 11] \times [4, 6]\} \quad (28)$$

The difference in the age value is due to the “unrolled” domain compared to the periodic domain. It corresponds to the duration of two cell cycles.

Figure 5 illustrates all the trajectories that can reach the target set for ovulation.

The left panel of Figure 5 illustrates the projection, on the age-maturity plan, of the changes in the back-

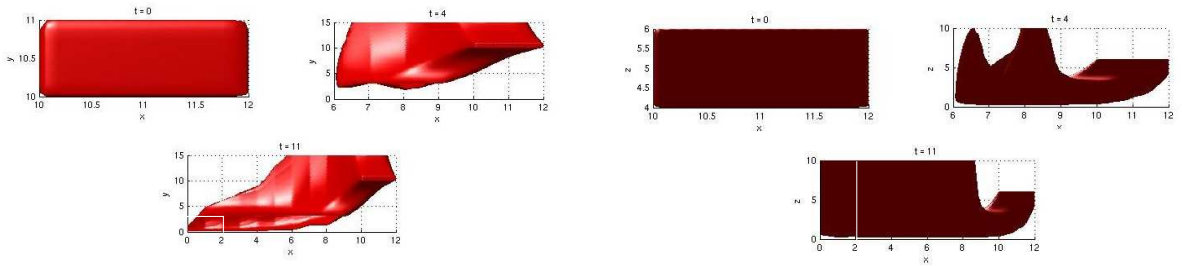

Figure 5: Evolution in time of the backwards reachable set for ovulatory follicles. The figure on the left gives the projection of the 3D set on the $(a_1-\gamma_1)$ plan, and the figure on the right gives the projection of the 3D set on the $(a_1-\phi_{f1})$ plan.

wards reachable set. Time $t = 0$ (first subplot) is ovulation time, and we can see the square representing the projection of the target set \mathcal{M}_o . At time $t = 4$, the set area has increased, including all states that can join the target set in less than 4 time units (2 time units roughly correspond to 1 cell cycle duration). The backwards reachable set at time $t = 11$ represents the set of states which need a maximum duration of 11 time units to reach the target set for ovulation. We chose to stop the simulation at this time as it contains the initial conditions used for the simulation represented in Figure 3. The “staircase” shape of the backwards reachable set is due to the dynamics in the cell cycle: the maturity in phase 1 increases with age, and in phase 2, the maturity remains unchanged as the age increases, which yields the flat part of the staircase. An instance of the flat part can be seen at time $t = 11$ between $a_1 = 7$ and $a_1 = 8$.

The right panel of Figure 5 illustrates the projection, on the age-cell density plan, of the temporal changes in the backwards reachable set. We can also see at time $t = 0$ the projection of the target set \mathcal{M}_o . At time $t = 11$ a large part of the age-cell density domain allows to reach the target set. From age $a_1 = 9$, the cell density variable increases with age to reach the target set. This is in agreement with the cell density dynamics in phase 3.

The backwards reachable set of \mathcal{M}_o nearly contains the whole spatial domain. It is an overapproximation of the initial states that allow to reach the target set. Indeed, it does not only contain the trajectories of the characteristics of the ovulatory follicle, but also those starting from initial conditions that do not arise on a physiological ground. Basing on biological knowledge, we can thus select from the overapproximated set, the physiologically-meaningful subset: we assume that all cells are initially within the cell cycle, at their first

generation, so that the subset of admissible initial conditions is defined by $\{(a_1(t_0), \gamma_1(t_0)) \in [0, a_2] \times [0, \gamma_s]\}$. This subset is delimited by the white line on Figure 5.

The target set \mathcal{M}_a for atresia is defined by the ranges reached by the characteristics of atretic follicles:

$$\mathcal{M}_a = \{(a_1, \gamma_1, \phi_{f1}) \in [8, 10] \times [3, 4] \times [2, 4]\} \quad (29)$$

Figure 6 illustrates all the trajectories that fall into the target set for an atretic follicle.

The left panel of Figure 6 illustrates the projection, on the age-maturity plan, of the changes in the back-

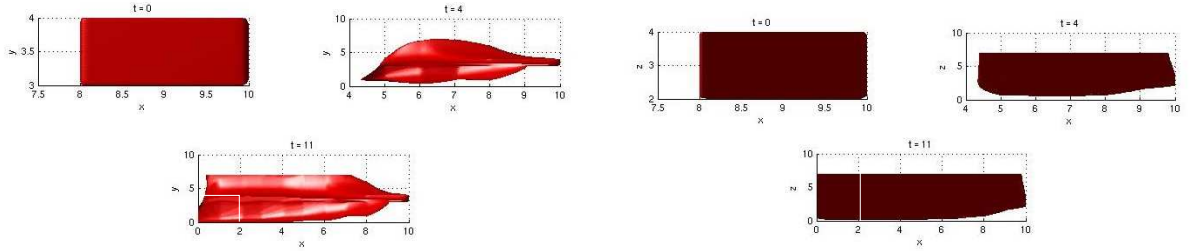

Figure 6: Evolution in time of the backwards reachable set for atretic follicles. The figure on the left gives the projection of the 3D set on the $(a_1-\gamma_1)$ plan, the figure on the right gives the projection of the 3D set on the $(a_1-\phi_{f1})$ plan.

wards reachable set. Some states in the target set are initially in the cell cycle, thus we can recognize the “staircase” shape induced by the dynamics within the cell cycle phases. The right panel of Figure 6 illustrates the projection, on the age-cell density plan, of the temporal changes in the backwards reachable set. The set area increases, and at time $t = 11$, it roughly contains the whole domain.

Once again, the set of initial states leading to atresia is overapproximated, and we can apply the same constraints as in the ovulatory case on the initial conditions, delimited by the white line on Figure 6.

The initial conditions leading to ovulation or atresia, that respect the physiological constraints, are roughly superimposed, and contain the whole subset of admissible initial conditions. Thus we cannot distinguish *a priori* ovulatory trajectories from atretic ones. This result agrees with physiological knowledge, as there is no predestination in follicular fate [9].

Although the initial conditions do not enable to determine whether a follicle is ovulatory or atretic, there is a moment when trajectories leading to ovulation or to atresia diverge. The moment when the separation takes place corresponds to the physiological time of selection, when a few follicles follow an ovulatory trajectory whereas the others follow an atretic one.

4 Discussion and perspectives

We have characterized the backwards reachable sets for both ovulatory and atretic follicles. This control problem has been solved by studying the characteristics of the conservation laws that describe the trajectories of ovarian follicles. The HJB equations representing the backwards reachable sets have been solved numerically for one characteristic curve, and allow to characterize the set of initial conditions that lead a characteristic into the target set either for ovulation or atresia.

We have used the backwards reachable sets theory for a problem which is not entirely continuous, as there are discontinuities at the transitions between each cellular phase. Hence, we studied each phase separately, assuming that the transitions at the boundaries were continuous. Actually, we deal with a hybrid problem,

as each cellular phase has its proper dynamics. As far as time dependent HJB equations are concerned, elements of a theory for hybrid systems are established, especially concerning “reach-avoid” sets [10], but it is not complete yet, and not directly applicable to our problem. Viability theory also considers reachable sets for hybrid systems [11], but the algorithms used are not as accurate as level set methods, as they use a different representation of the reachable sets [7]. Yet the numerical results we have obtained with the level set methods seem correct as the continuous part of the system is solved with highly accurate algorithms and the hybrid part is ruled by continuity conditions.

We have solved a simplified numerical problem dealing with a single characteristic of a follicle, as the simulation tool needs too huge memory to solve higher dimensional problems. The backwards reachable sets obtained show that it is possible to find a correct control law to steer a large set of initial conditions into the target set, and they give information on the maximum necessary duration before reaching the target.

If the simulation of more than one characteristic were possible, as a compromise would be made in the optimisation procedure between all possible trajectories, they would no longer be independent and we would expect the backwards reachable sets to be smaller. Indeed, we speculate that physiologically, a larger set in case of a single growing follicle ensures the ovulation succes, while a smaller set in case of several simultaneously growing follicles limits the ovulation rate and underlies in part the selection process. Yet this assumption needs improvement of the numerical implementation to be tested.

We have studied by now the open-loop problem, for the ovulation of one follicle. This situation is close to therapeutic situations of ovarian stimulations. Hence, the control laws obtained may be usefull in improving therapeutic schemes. Yet, the physiological situation si even more complexe, as follicular ovulation can occur only when ovulation has been triggered by a hormonal signal in response to the dynamics of the whole follicle population (condition (7)). A great challenge will be to solve the closed-loop multi-scale system, that takes into account both ovulation triggering and the interactions between follicles.

References

- [1] G.S. GREENWALD and S.K. ROY. Follicular development and its control. In E. Knobil and J.D. Neill, editors, *The Physiology of Reproduction*, pages pp. 629–724. Raven Press, New York, (1994).
- [2] N. ECHENIM, D. MONNIAUX, M. SORINE, and F. CLEMENT. Multi-scale modeling of the follicle selection process in the ovary. *Math. Biosci.*, 198:pp. 57–79, (2005).
- [3] O. BESSON and J. POUSIN. Existence and uniqueness of solutions for linear conservation laws with velocity field in L^∞ . *Preprint*, (2005).
- [4] L.C. EVANS. *Partial differential equations*. AMS, California, (1998).
- [5] A.B. KURZHANSKI and P. VARAIYA. Dynamic optimization for reachability problems. *J. Optim. Theory Appl.*, 108:pp. 227–251, (2001).
- [6] A.E. BRYSON and Y.-C. HO. *Applied optimal control*. Hemisphere, Washington DC, (1975).
- [7] I.M. MITCHELL. *Application of level set methods to control and reachability problems in continuous and hybrid systems*. PhD thesis, Stanford University, (1975).
- [8] I.M. MITCHELL. *A toolbox of level set methods*.
- [9] A. GOUGEON. Regulation of ovarian follicular development in primates: facts and hypotheses. *Endocr. Rev.*, 17:121–150, (1996).
- [10] C.J. TOMLIN, I. MITCHELL, A.M. BAYEN, and M. OISHI. Computational techniques for the verification of hybrid systems. *Proc of the IEEE Trans. Automat. Contr.*, 91:pp. 986–1001, (2003).

- [11] J-P. AUBIN. Impulse differential inclusions and hybrid systems: a viability approach. *IEEE Trans. Automat. Contr.*, 47:pp. 2–20, (2002).

A Regularization

A.1 Dynamics of the regularization phases

The variable ϕ_{fc} is not continuous at the transition between each cellular phase, due to the conditions (11) and (12). We introduce two new phases to regularize ϕ_{fc} , namely phase 1-2 and phase-mit:

- the dynamics in phase 1-2 allow to regularize the jump condition (11) on ϕ_{fc} from phase 1 to phase 2;
- the dynamics in phase-mit allow to regularize the jump condition (12) on ϕ_{fc} from phase 2 to phase 1.

The introduction of these phases alters the spatial domain as represented on Figure 7, where phase 1= $\{(a, \gamma) \in [0, a_1] \times [0, \gamma_s]\}$, phase 1-2= $\{(a, \gamma) \in [a_1, a_{12}] \times [0, \gamma_s]\}$, phase 2= $\{(a, \gamma) \in [a_{12}, a_2] \times [0, \gamma_s]\}$, phase-mit= $\{(a, \gamma) \in [a_2, a_{mit}] \times [0, \gamma_s]\}$ and phase 3= $\{(a, \gamma) \in [0, \infty) \times [\gamma_s, \infty)\}$

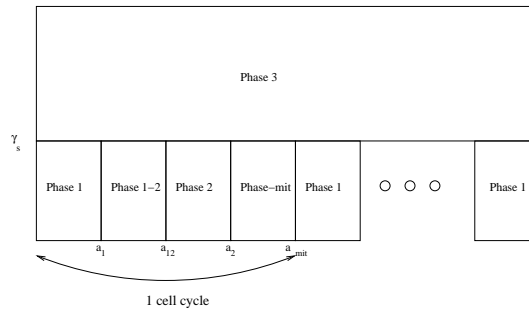

Figure 7: Introduction of two new phases

The dynamics in phase 1, phase 2 and phase 3 remain unchanged as defined in Eqs.(2,3,4). The dynamics in phase 1-2 and the Hamiltonian H_{f1-2} are chosen as:

$$\begin{aligned} \forall k \in \mathbb{N}, \forall c = 1 \dots n \\ \forall (a_c, \gamma_c, \phi_{fc}) \in [a_1 + ka_{mit}, a_{12} + ka_{mit}] \times [0, \gamma_s] \times [0, \infty) \\ \begin{cases} \frac{da_c}{dt} = 1 \\ \frac{d\gamma_c}{dt} = 0 \\ \frac{d\phi_{fc}}{dt} = k_1 \phi_{fc} \end{cases} \end{aligned} \quad (30)$$

$$H_{f1-2} = \sum_{c=1}^n p_{a_c} + k_1 \sum_{c=1}^n p_{\phi_{fc}} \phi_{fc} \quad (31)$$

Let t_1 such as $a_c(t_1) = a_1$, and t_{12} such as $a_c(t_{12}) = a_{12}$.

Thanks to this additional phase, condition (11) becomes:

$$\phi_{fc}(t_{12}) = (g_1 u_f(t_1) + g_2) \phi_{fc}(t_1)$$

According to the dynamics (30) in phase 1-2,

$$\phi_{fc}(t_{12}) = \phi_{fc}(t_1) \exp(k_1(t_{12} - t_1)) = \phi_{fc}(t_1) \exp(k_1(a_{12} - a_1))$$

so we identify

$$k_1 = \frac{\ln(g_1 u_f(t_1) + g_2)}{a_{12} - a_1}$$

The dynamics in phase-mit and the Hamiltonian H_{fmit} are chosen as:

$$\begin{aligned} \forall \quad & k \in \mathbb{N}, \forall c = 1 \dots n \\ \forall \quad & (a_c, \gamma_c, \phi_{fc}) \in [a_2 + ka_{mit}, (k+1)a_{mit}] \times [0, \gamma_s] \times [0, \infty) \\ & \begin{cases} \frac{da_c}{dt} = 1 \\ \frac{d\gamma_c}{dt} = 0 \\ \frac{d\phi_{fc}}{dt} = k_2 \phi_{fc} \end{cases} \end{aligned} \quad (32)$$

$$H_{fmit} = \sum_{c=1}^n p_{a_c} + k_2 \sum_{c=1}^n p_{\phi_{fc}} \phi_{fc} \quad (33)$$

Let t_2 such as $a_c(t_2) = a_2$, and t_{mit} such as $a_c(t_{mit}) = a_{mit}$.
Thanks to this additionnal phase, condition (12) becomes:

$$2\phi_{fc}(t_2) = (g_1 u_f(t_{mit}) + g_2) \phi_{fc}(t_{mit})$$

According to the dynamics (32) in phase-mit,

$$\phi_{fc}(t_{mit}) = \phi_{fc}(t_2) \exp(k_2(t_{mit} - t_2)) = \phi_{fc}(t_2) \exp(k_1(a_{mit} - a_2))$$

So we identify

$$k_2 = \frac{\ln\left(\frac{2}{g_1 u_f(t_{mit}) + g_2}\right)}{a_{mit} - a_2}$$

This regularization does not deeply modify the dynamics of the system, as the age variable is only delayed. Since the age is basically used as a phase marker, the same dynamics as previously can be obtained with another numerical calibration of the system.

A.2 Simplification of the regularization phases

We show below that $u_f(t_1) = u_f(t_{mit})$, which permits to simplify the regularization process and aggregate the two regularization phases into phase 2.

Both $u_f(t_1)$ and $u_f(t_{mit})$ depend on the values of $A(t_1)$, $B(t_1)$, and $A(t_{mit})$, $B(t_{mit})$ (see Eq.(23)).

At time t_1 corresponding to the end of phase 1,

$$A(t_1) = \tau_{hf} \sum_{c=1}^n (c_1 \gamma_c(t_1) + c_2) p_{\gamma_c}(t_1) - \tau_{hf} c_1 \sum_{c=1}^n \phi_{fc}(t_1) p_{\phi_{fc}}(t_1) \quad \text{and} \quad B(t_1) = \tau_{gf} g_1 \sum_{c=1}^n p_{a_c}(t_1).$$

The covariables p_{x_c} verify:

$$\frac{dp_{x_c}}{dt} = -\frac{\partial H_f}{\partial x_c}, \quad (34)$$

where H_f is the Hamiltonian, and x_c is a_c, γ_c or ϕ_{fc} [6].

At the end of phase 1-2 at time t_{12} given Eqs.(34) and (31):

$$\begin{cases} p_{a_c}(t_{12}) = p_{a_c}(t_1) \\ p_{\gamma_c}(t_{12}) = p_{\gamma_c}(t_1) \\ p_{\phi_{fc}}(t_{12}) = \frac{1}{(g_1 u_f(t_1) + g_2)} p_{\phi_{fc}}(t_1) \\ \gamma_c(t_{12}) = \gamma_c(t_1) \\ \phi_{fc}(t_{12}) = (g_1 u_f(t_1) + g_2) \phi_{fc}(t_1) \end{cases} \quad (35)$$

Until the end of phase 2, at time t_2 , all the variable values remain unchanged to those at time t_{12} . At the end of phase-mit, at time t_{mit} :

$$\begin{cases} p_{a_c}(t_{mit}) = p_{a_c}(t_2) \\ p_{\gamma_c}(t_{mit}) = p_{\gamma_c}(t_2) \\ p_{\phi_{fc}}(t_{mit}) = \frac{(g_1 u_f(t_{mit}) + g_2)}{2} p_{\phi_{fc}}(t_2) \\ \gamma_c(t_{mit}) = \gamma_c(t_2) \\ \phi_{fc}(t_{mit}) = \frac{2}{(g_1 u_f(t_2) + g_2)} \phi_{fc}(t_2) \end{cases} \quad (36)$$

Thus, at the end of phase-mit, before entering once again phase 1:

$$\begin{aligned} A(t_{mit}) &= \tau_{hf} \sum_{c=1}^n (c_1 \gamma_c(t_{mit}) + c_2) p_{\gamma_c}(t_{mit}) - \tau_{hf} c_1 \sum_{c=1}^n \phi_{fc}(t_{mit}) p_{\phi_{fc}}(t_{mit}) \\ &= \tau_{hf} \sum_{c=1}^n (c_1 \gamma_c(t_1) + c_2) p_{\gamma_c}(t_1) \\ &\quad - \tau_{hf} c_1 \sum_{c=1}^n \frac{2}{(g_1 u_f(t_{mit}) + g_2)} (g_1 u_f(t_1) + g_2) \phi_{fc}(t_1) \frac{(g_1 u_f(t_{mit}) + g_2)}{2} \frac{1}{(g_1 u_f(t_1) + g_2)} p_{\phi_{fc}}(t_1) \\ &= A(t_1) \end{aligned}$$

$$\text{and } B(t_{mit}) = \tau_{gf} g_1 \sum_{c=1}^n p_{ac}(t_{mit}) = B(t_1)$$

We have shown that $A(t_{mit}) = A(t_1)$ and $B(t_{mit}) = B(t_1)$. Thus, the control applied at time t_{mit} is the same as the control applied at time t_1 .

It is worth noticing that whatever the control applied at time t_1 is, the value of the variable ϕ_{fc} at time t_{mit} is $\phi_{fc}(t_{mit}) = 2\phi_{fc}(t_1)$ (see Eqs (35 and 36)). This allows to remove the regularization phases and utilize phase 2 to introduce linear dynamics for ϕ_{fc} , as in Eq (19), and to operate the regularization and obtain at mitosis $\phi_{fc}(t_2) = 2\phi_{fc}(t_1)$.

B Optimization with constraints

To take the constraints $U_{min} \leq u_f \leq U \leq U_{max}$ into account, we add Lagrangian multipliers to the Hamiltonian H_{f1} in the cases (24,25,26), and to the Hamiltonian H_{f3} in the case (27).

In phase 1 we obtain the new Hamiltonian:

$$H_1 = T_1 - A \exp\left(-\frac{u_f}{u}\right) + B u_f + C U + \nu_1 (u_f - U) + \nu_2 (U_{min} - u_f) + \nu_3 (U - U_{max})$$

where T_1 contains all terms that do not depend on the control terms.

We use the theorem of Kuhn-Tucker:

$$\begin{cases} \frac{\partial H_1}{\partial U} = 0 \\ \frac{\partial H_1}{\partial u_f} = 0 \\ u_f = U \text{ and } \nu_1 > 0 \\ u_f = U_{min} \text{ and } \nu_2 > 0 \\ U = U_{max} \text{ and } \nu_3 > 0 \end{cases}$$

and solve one of the following systems:

$$\begin{array}{l} \nu_1 \text{ and } \nu_2 \text{ are active } (\nu_1 > 0, \nu_2 > 0) \\ \left\{ \begin{array}{l} C - \nu_1 = 0 \\ \frac{A}{u} \exp\left(\frac{-u_f}{u}\right) + B + \nu_1 - \nu_2 = 0 \\ U = u_f \\ u_f = U_{min} \end{array} \right. \end{array} \quad \begin{array}{l} \nu_1 \text{ and } \nu_3 \text{ are active } (\nu_1 > 0, \nu_3 > 0) \\ \left\{ \begin{array}{l} C - \nu_1 + \nu_3 = 0 \\ \frac{A}{u} \exp\left(\frac{-u_f}{u}\right) + B + \nu_1 = 0 \\ U = u_f \\ u_f = U_{max} \end{array} \right. \end{array} \quad \begin{array}{l} \text{only } \nu_1 \text{ is active } (\nu_1 > 0) \\ \left\{ \begin{array}{l} C - \nu_1 = 0 \\ \frac{A}{u} \exp\left(\frac{-u_f}{u}\right) + B + \nu_1 = 0 \\ U = u_f \end{array} \right. \end{array}$$

In case (24) $C > 0$, $A < 0$ and $B < 0$

- when ν_1 and ν_2 are active we have

$$\left\{ \begin{array}{l} \nu_1 = C > 0 \\ \nu_2 = C + B + \frac{A}{u} \exp\left(\frac{-U_{min}}{u}\right) \\ u_f = U_{min} \\ U = U_{min} \end{array} \right. \quad \text{so that } \nu_2 > 0 \iff B + C > -\frac{A}{u} \exp\left(\frac{-U_{min}}{u}\right)$$

- when ν_1 and ν_3 are active we have

$$\left\{ \begin{array}{l} \nu_3 = -C + \nu_1 \\ \nu_1 = -B - \frac{A}{u} \exp\left(\frac{-U_{max}}{u}\right) > 0 \\ u_f = U_{max} \\ U = U_{max} \end{array} \right. \quad \text{so that } \nu_3 > 0 \iff B + C < -\frac{A}{u} \exp\left(\frac{-U_{max}}{u}\right)$$

- when only ν_1 is active we have

$$\left\{ \begin{array}{l} \nu_1 = C > 0 \\ u_f = -\bar{u} \ln\left(-\frac{(B+C)\bar{u}}{A}\right) \\ U = u_f \end{array} \right.$$

We can verify that for $-\frac{A}{u} \exp\left(\frac{-U_{max}}{u}\right) \leq B + C \leq -\frac{A}{u} \exp\left(\frac{-U_{min}}{u}\right)$ we have $U_{min} \leq u_f = U \leq U_{max}$

In cases (25) and (26), either $C > 0$, $A < 0$ and $B > 0$ or $C > 0$, $A > 0$ and $B < 0$

- when ν_1 and ν_2 are active we have

$$\left\{ \begin{array}{l} \nu_1 = C > 0 \\ \nu_2 = C + B + \frac{A}{u} \exp\left(\frac{-U_{min}}{u}\right) \\ u_f = U_{min} \\ U = U_{min} \end{array} \right. \quad \text{so that } \nu_2 > 0 \iff B + C > -\frac{A}{u} \exp\left(\frac{-U_{min}}{u}\right)$$

- when ν_1 and ν_3 are active we have

$$\left\{ \begin{array}{l} \nu_3 = -C + \nu_1 \\ \nu_1 = -B - \frac{A}{u} \exp\left(\frac{-U_{max}}{u}\right) \\ u_f = U_{max} \\ U = U_{max} \end{array} \right. \quad \text{so that } \begin{cases} \nu_1 > 0 \iff -B - \frac{A}{u} \exp\left(\frac{-U_{max}}{u}\right) > 0 \\ \nu_1 > 0 \iff B < -\frac{A}{u} \exp\left(\frac{-U_{max}}{u}\right) \\ \nu_1 > 0 \implies \nu_3 > 0 \end{cases}$$

- when only ν_1 is active we have

$$\left\{ \begin{array}{l} \nu_1 = C > 0 \\ u_f = -\bar{u} \ln\left(-\frac{(B+C)\bar{u}}{A}\right) \\ U = u_f \end{array} \right.$$

In case (27) the new Hamiltonian in phase 3 is

$$H_3 = T_3 - A \exp\left(-\frac{u_f}{u}\right) + CU + \nu_1(u_f - U) + \nu_2(u_f - U_{min}) + \nu_3(U - U_{max})$$

where T_3 contains all terms that do not depend on the control terms and $C > 0$ and $A < 0$.

- when ν_1 and ν_2 are active we have

$$\begin{cases} \nu_1 = C > 0 \\ \nu_2 = C + \frac{A}{u} \exp\left(\frac{-u_f}{u}\right) \\ u_f = U_{min} \\ U = U_{min} \end{cases} \quad \text{so that } \nu_2 > 0 \iff C > -\frac{A}{u} \exp\left(\frac{-U_{min}}{u}\right)$$

- when ν_1 and ν_3 are active we have

$$\begin{cases} \nu_3 = -C + \nu_1 > 0 \\ \nu_1 = -\frac{A}{u} \exp\left(\frac{-U_{max}}{u}\right) > 0 \\ u_f = U_{max} \\ U = U_{max} \end{cases}$$

- The situation where only ν_1 is active would occur when

$$\begin{cases} C \leq -\frac{A}{u} \exp\left(\frac{-U_{min}}{u}\right) \\ -\frac{A}{u} \exp\left(\frac{-U_{max}}{u}\right) \leq 0 \end{cases}$$

which never occurs as $A < 0$.