



HAL
open science

High-Level Energy Estimation for DSP Systems

Johann Laurent, Eric Senn, Nathalie Julien, Eric Martin

► **To cite this version:**

Johann Laurent, Eric Senn, Nathalie Julien, Eric Martin. High-Level Energy Estimation for DSP Systems. 2001, pp 3.1.1-3.1.10. hal-00077563

HAL Id: hal-00077563

<https://hal.science/hal-00077563v1>

Submitted on 31 May 2006

HAL is a multi-disciplinary open access archive for the deposit and dissemination of scientific research documents, whether they are published or not. The documents may come from teaching and research institutions in France or abroad, or from public or private research centers.

L'archive ouverte pluridisciplinaire **HAL**, est destinée au dépôt et à la diffusion de documents scientifiques de niveau recherche, publiés ou non, émanant des établissements d'enseignement et de recherche français ou étrangers, des laboratoires publics ou privés.

High-Level Energy Estimation for DSP Systems

Johann Laurent, Eric Senn, Nathalie Julien, Eric Martin

LESTER Laboratory, South Brittany University, 2 rue Saint Maudé BP 92116 56325
Lorient CEDEX, France
laurent@iuplo.univ-ubs.fr

Abstract. A new approach for estimating Digital Signal Processors' energy consumption is presented. Our energy consumption model is based on a functional analysis of the DSP's core. Several consumption rules are determined. They give, from specific parameters extracted from the algorithm's source code, the consumption of every functional block in the DSP, and lead to the application's overall energy consumption. The last generation Texas Instruments C6201 is studied; the methodology is not restricted to this sole processor however. The method is finally demonstrated on a classical signal processing algorithm; the gap between measures and estimations is lower than 8%.

1 Introduction

Embedded applications have grown more and more complex, involving more computing resources and therefore increasing the overall energy consumption. Repercussions are twofold: cooling devices are getting bigger in size and cost, and batteries' life is decreased. For all mobile applications, reducing power consumption is now a vital challenge. As stated in [1], algorithmic transformations have a greater impact on power consumption than technological optimizations. Being able to precisely estimate an algorithm's energy consumption is then extremely interesting. Hence, optimizations are performed early in the system's design flow. Time to market is reduced.

Digital signal processors (DSP) are greatly used in many applications (digital communication, real-time codec ...). Today's works on DSPs' consumption estimation mainly rely on instruction level models [2][7][8]. That implies to measure the consumption of every instruction in the instruction set, and to consider every possible interaction between two or more instructions. This is rather difficult, and very time consuming, for last generation DSPs feature very elaborate architectures. They have deep pipelines, complex VLIW instruction sets, memory caches, and some of them are superscalar. Instruction sets of modern DSPs are constantly evolving, and parallelism possibilities must be considered now. Moreover, measures ought to be done again whenever the DSP's architecture is changed. Finally, as modern applications require much memory space, and because external memory accesses consume more than internal [1][4], memory accesses should be considered too.

Our approach is based on a functional decomposition of the DSP. Each functional block's power consumption is computed from a set of consumption rules. These rules use some of the application's relevant features, in the form of parameters extracted from the algorithm. Section 2 presents the methodology and explains how functional analysis is performed. Section 3 exhibits the consumption laws' determination. Section 4 shows how relevant parameters are extracted from the algorithm. The method is applied to the FIR16 filter. Estimation results and measurements are eventually compared to validate the methodology.

2 Methodology and Functional Analysis

2.1 The Framework

Our goal is to reduce the energy consumption of digital signal processing applications. A method for energy estimation is currently being developed, together with energy optimization strategies. The DSP's energy consumption is estimated directly from the algorithm written in C. The complete methodology is sketched on figure 1.

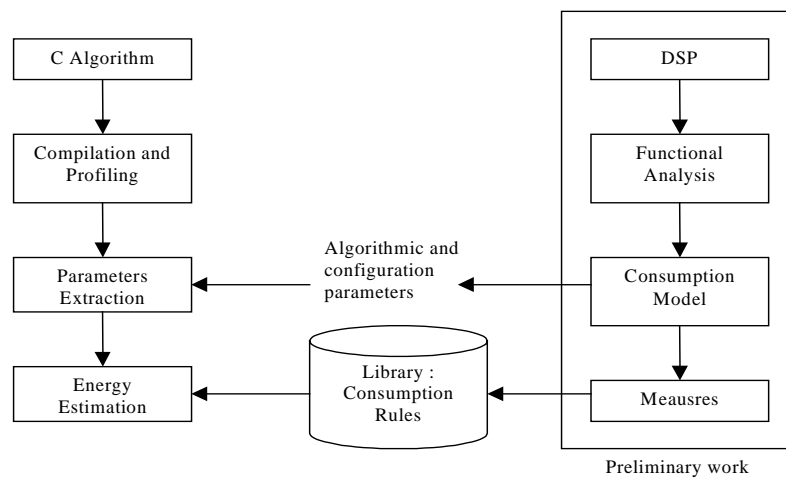

Fig. 1. The Methodology

First step is to compile and profile the C algorithm. The algorithm is sliced in *basic blocks* (a contiguous section of code with no loop and no branch [2]); specific parameters are extracted, such as the internal memory access rate, the number of processing units used per cycle, the parallelism rate (provided that the DSP has parallelism capabilities), and the number of times a basic block is executed. Second step is to

estimate every basic block's power consumption. The application's overall energy consumption is finally computed.

The estimation model relies on a set of *consumption rules*, gathered in a library. In this paper, only the energy estimation model will be discussed, as well as the consumption rules' determination and validation.

2.2 Functional Analysis

To actually build the library, a functional analysis of the targeted DSP is first performed. Non-consuming parts of the DSP are discarded (control registers of the DMA for instance, since they do not commute often enough).

By adding or removing blocks or sub-blocks, the very general representation on figure 2 can be modified, depending on the targeted processor. In this model, 4 high-level blocks are exhibited: the **CU** block (Control Unit), the **MMU** (Memory Management Unit), the **IMU** (Instructions Management Unit) and the **PU** (Processing Unit). Each of them has several sub-blocks.

The functional diagram shows how blocks interact with each other. For instance, the DMA (Direct Memory Access) can generate an interaction between the MMU and PU if data are directly loaded from the external memory. An interaction exists between the IMU and the PU for instructions are first fetched in the IMU, then executed in the PU. Interactions exist between the CU and every other block, since it contains the DSP's control registers.

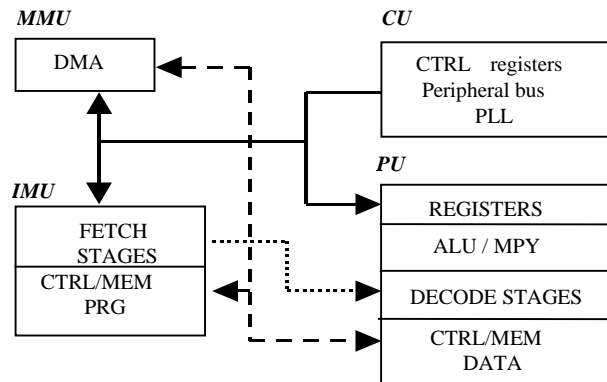

Fig. 2. Functional Diagram

The power consumption induced by every interaction on this diagram is investigated afterward. The next section presents a complete analysis for a real DSP.

2.3 The TMS320C6201's Study

The TMS320C6201, one of the last generation Texas Instruments' DSP, has a relatively complex architecture, since it has a deep pipeline (up to 11 stages), VLIW instructions (256 bits instructions), parallelism capabilities (up to 8 instructions in parallel), and an internal program memory that can be used in cache mode. Its functional diagram is presented in figure 3 (only inter-blocks interactions are shown).

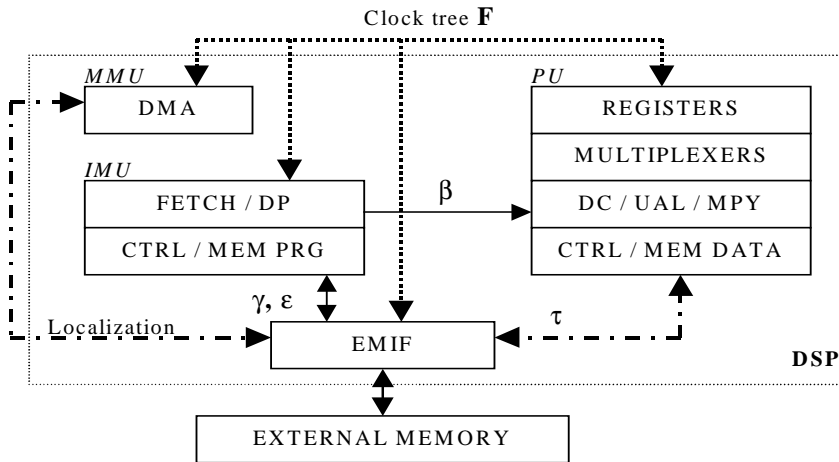

Fig. 3. Functional Analysis for the TMS320C6201

The *clock tree* is represented as an external interaction to every block. The consumption it induces is rather high since 200MHz is the DSP's nominal frequency.

The pipeline's DECODE stage is broken in 2: the dispatching part (DP) is included in the IMU, and the instructions decoding (DC) remains in the PU. In this DSP indeed, decoding is actually done in the processing unit, whereas dispatching is realized in the fetch stage.

The EMIF (External Memory InterFace) tackles every external memory access for both instructions and data. This new block has its own interactions. The first one, to the IMU, is only activated when the CPU loads instructions from the external memory (in case of a cache miss for instance). The second, to the PU, is activated when data are loaded.

Although other interactions than those reported on this diagram may exist, they are not considered for they do not produce any significant enough power consumption.

The power consumption actually induced by every interaction depends on parameters from the algorithm. Configuration parameters are considered apart: they are the frequency (F), and the data mapping in memory. Regular algorithmic parameters are the average number of processing units used per cycle (β), the cache miss rate (γ), the in-external instructions (program) read rate (ϵ) and the in-external data access rate (τ).

In the following, every interaction will be considered to produce the consumption rules which are mathematical functions of the former parameters.

3 Consumption Laws Determination

In this section, the energy consumption of every block in the functional diagram is determined. This consumption actually depends on the way a block interacts with each other (in this way, an interaction is said *able to induce power consumption*).

Several programs were used to stimulate independently every functional block. These programs (also called *scenarios*) are unbounded loops, written in assembly language, that excite only specific parts in the DSP. The branch at the end of the loop is negligible when the loop size is more than 4000 instructions. For every scenario, several configuration and algorithmic parameters were used. Each time, the energy consumption was measured and plotted on a set of charts from which the block's consumption rule is eventually identified. The consumption law for the block is eventually identified from the set of charts.

To know how much energy was consumed during a scenario, it is necessary to measure the average current consumed by the DSP's core (I_{CORE}) and the scenario's execution time (T_{TOTAL}). Given the core supply voltage ($V_{dd} = 2.5V$), it is possible to determine the average total energy E_{TOTAL} :

$$E_{TOTAL} = I_{CORE} * T_{TOTAL} * V_{dd} \quad (1)$$

Identically, it is possible to measure the energy consumed by a basic block E_{BB} :

$$E_{BB} = I_{CORE} * T_{EXE} * V_{dd} \quad (2)$$

Where T_{EXE} is the block's execution time. Hence, to estimate the algorithm's overall energy consumption, by adding up every basic block's energy :

$$E_{TOTAL} = \Sigma E_{BB} \quad (3)$$

In the following, consumption laws' determination is demonstrated for the IMU (Instructions Management Unit) and the PU (Processing Unit).

3.1 The IMU's Consumption Rules

The IMU includes the fetch stage and the program memory with its controller. In the TMS320C6201, the program memory works in four modes. The first one is the MAPPED mode where all the instructions are in the internal program memory. The second is the CACHE mode, where external accesses are done whenever the instructions are not in the cache (cache miss). The third is the FREEZE mode, similar to the CACHE mode but the cache is only read and never written. The last one is the BY-PASS mode, where all the instructions are read from external memory.

Table 1 shows the measured average current and energy consumed by the DSP's core for one loop's iteration. The results are identical for the CACHE and the FREEZE mode, since no cache miss was generated in this scenario (only CACHE mode appears in the table).

MEMORY MODE	FREQUENCY	CURRENT (mA)	ENERGY (μ j)
MAPPED	133MHz	1300	24.44
CACHE		1342	25.22
BYPASS		795	120
MAPPED	160MHz	1554	24.3
CACHE		1595	24.9
BYPASS		948	237
MAPPED	200MHz	1840	23
CACHE		1904	23.8
BYPASS		1175	235

Table 1. Memory Modes Comparison

Obviously, the current is not the only parameter for comparing the TMS's memory modes. Indeed, measured current is lower in BYPASS mode than in MAPPED (about -39%), but much more energy is used (at least +390%). Energy is the most important parameter, not only for embedded applications; however, it is necessary to measure currents to elaborate our consumption laws.

Since sub-blocks change with the memory mode, four rules have to be elaborated (the cache controller is only present in CACHE and FREEZE modes, for example). For each memory mode, a scenario was created to stimulate only the block we wanted. For every scenario, the PU (Processing Unit) was never excited. After several measurements for different algorithmic and configuration parameters' values, a mathematical function is sought that gives the consumption rule.

Table 2 presents the consumption rules for the 4 memory modes.

<i>MEMORY MODES</i>	<i>CONSUMPTION RULES</i>	
MAPPED	$I = (a\alpha + b)F + c\alpha + d$	F: MHz a = 5.21mA/MHz; b = 4.19mA/MHz c = 42.4mA; d = 7.6mA
BYPASS	$I = (a + b)F + c$	a = 5.68mA/MHz; b = 4.19mA/MHz c = 38.4mA
CACHE	$I = S\alpha F\gamma + T\alpha F + UF\gamma + VF + W\alpha\gamma + X\alpha + Y\gamma + Z$	
FREEZE	$I = S\alpha F\epsilon + T\alpha F + UF\epsilon + VF + W\alpha\epsilon + X\alpha + Y\epsilon + Z$	

Table 2. Consumption rules for Memory Modes

For the CACHE and FREEZE mode, coefficients S, T, U, V, W, X, Y and Z depend on ϵ or γ ranges. The FREEZE mode was split in 2 depending on ϵ ($\epsilon \leq 25\%$ or $\epsilon > 25\%$). The CACHE mode was split in 3 depending on γ ($\gamma < 50\%$, $50\% \leq \gamma \leq 75\%$, $\gamma > 75\%$).

For these 2 modes, the consumption is constant if the parallelism rate (α) is greater or equal to 0.5 thus the current is estimated with the rules for γ or ϵ equals 0%.

3.2 Processing Unit Rules

Parameters involved in the PU's consumption rule are the number of processing units per cycle (β) and the operating frequency (F). β equals 8 when all the processing units are used, 0 on the contrary. In this case, β is 8 times the parallelism rate α (which varies from 1 to 1/8). The consumption rule is [I_{pu} : average current (mA)] :

$$I_{pu} = a\beta F \quad a=0.64mA/MHz; F: frequency (MHz) \quad (4)$$

The data variations (in size and value) are not considered since their influence on power consumption is negligible for this DSP [5].

4 Application

In this section energy estimation is applied on a classical signal processing algorithm : a FIR16 filter. The TMS320C6201 is targeted. Firstly, we show how configuration and algorithmic parameters are extracted from the algorithm. Secondly, estimations and measures are compared to validate our model.

4.1 Parameters' Extraction

The parameters we are extracting come from the former functional analysis for this particular DSP (see figure 3). For the IMU, every memory mode is investigated with γ and ϵ varying. The parallelism rate α gives the FETCH stage consumption. To calculate α , we count how many FP (Fetch Packets) and EP (Execute Packets) are used in the program, then we divide the number of EP by the number of FP; this ratio gives α .

Since the filter's coefficients and input samples are mapped in the internal data memory, we simply have to consider β for the PU (Processing Unit). The number of processing units used in one iteration of the program is counted. Then it is divided by the number of processor cycles necessary to execute the iteration; this ratio gives β .

The application's consumption is determined by adding up the contribution of every identified functional block (figure 3).

Table 2 compares measures and estimations for the MAPPED and BYPASS mode at the maximum DSP's frequency (F=200MHz).

		FIR 16		
		Global Estimate (μj)	Measures (μj)	Error (%)
Mapped		105	104	0.96
Bypass		791	794	-0.38

Table 3. FIR16 Energy Estimations and Measures (in μj per iteration)

The energy consumption is estimated with an error lower than 1%. The following results are for the CACHE and FREEZE mode with γ and ϵ varying. Figure 4 presents estimations and measures in FREEZE mode for ϵ ranging from 0 to 75%.

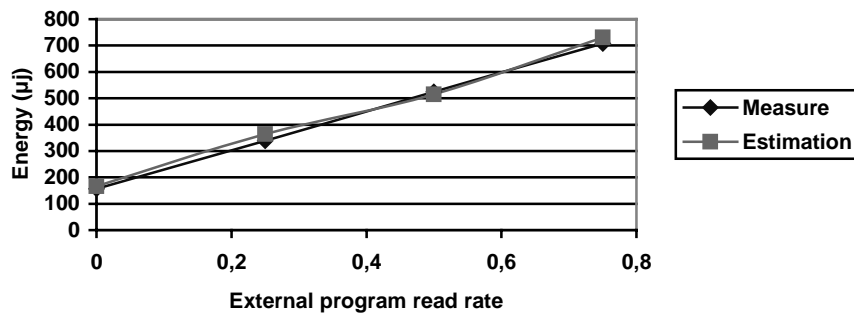

Fig. 4. FIR16 Energy Estimations and Measures

The maximum error is less than 7.4%. It is greater than in MAPPED or BYPASS mode because the model complexity increases, and approximations made to determine the consumption rule are stronger.

Figure 5 presents the results in CACHE mode when γ varies from 0 to 100%.

The maximum error in this mode is lower than 3.63%. In the very general case, estimation is performed by adding up every basic block's energy consumption (in our example, only one basic block was involved). For each basic block, parameters are extracted and energy estimated thanks to consumption rules. As stated before, the total energy is obtained this way (equation (3)).

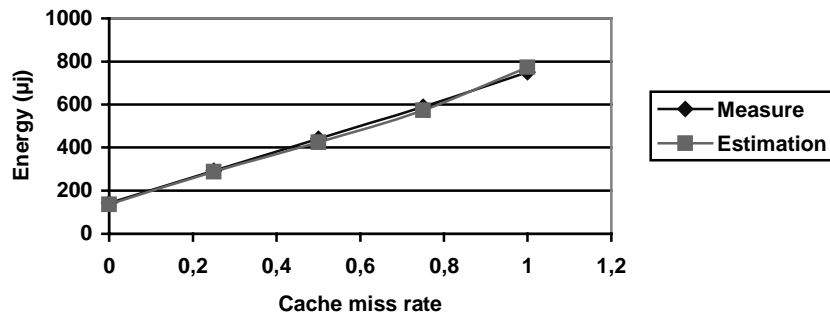

Fig. 5. FIR16 Energy Estimations and Measures

5 Conclusion

We propose a new approach to estimate the energy consumption of a DSP's application. It relies on a set of rules that permit, given specific parameters extracted from the algorithm, to estimate the application's energy consumption. In order to determine the set of consumption rules, a functional analysis of the DSP is first performed. The way interactions between functional blocks induce power consumption depends on several parameters which are clearly identified (configuration and algorithmic parameters). By running different scenario on the DSP, with different values for these parameters, a set of charts is obtained, from which the consumption rules are computed. The method was applied to a FIR 16 filter on a TMS320C6201 DSP. The difference between our estimations and measurements never exceeded 7.4%. Functional analysis appears a very efficient and straightforward method for energy optimization. Future works aim at the development of energy reduction strategies for high-level algorithmic transformations.

References

1. J.M. Rabaey, M. Pedram "Low power design methodologies" Kluwer Academic Publishers 1996.
2. Vivek Tiwari, Sharad Malik, Andrew Wolfe "Power analysis of embedded software: a first step towards software power minimisation." IEEE Transactions on VLSI Systems, December 1994.
3. Mike Tien-Chien-Lee, Vivek Tiwari, Sharad Malik and Masahiro Fujita "Power Analysis and Minimisation Techniques for Embedded DSP Software." IEEE Transactions on VLSI Systems, Vol5, N°1, March 1997.
4. P. Vanoostende et al. "Issues in low power design for telecom" IEEE 1995 p 591-593.
5. J.Laurent, N. Julien, E. Martin " High Level power Estimation for DSP" in proceedings of Sophia Antipolis Symposium on Micro Electronic, pages 112-118.

6. J.Laurent, N. Julien, E. Martin “*High Level Power Analysis for Embedded DSP Software*” Technical Committee on Computer Architecture Newsletter, January 2001, pages 41-46
<http://computer.org/tab/tcca/NEWS/jan2001/index.html>.
7. P.Laramie "*Instruction level power analysis and low power design methodology of a micro-processor*", Master Thesis, U.C. Berkeley.
8. C. Brandolese, W. Fornaciari, F. Salice, D. Sciuto “*An Instruction-Level Functionality-Based Energy Estimation Model for 32-bits Microprocesseur*” proceedings of Design Automation Conference 2000, pages 346-342