



HAL
open science

Noncommutative symmetric functions III: Deformations of Cauchy and convolution algebras

Gérard Henry Edmond Duchamp, A.A. Klyachko, Daniel Krob, Jean-Yves Thibon

► **To cite this version:**

Gérard Henry Edmond Duchamp, A.A. Klyachko, Daniel Krob, Jean-Yves Thibon. Noncommutative symmetric functions III: Deformations of Cauchy and convolution algebras. *Discrete Mathematics and Theoretical Computer Science*, 1997, Vol. 1, pp.159-216. 10.46298/dmtcs.231 . hal-00018540v1

HAL Id: hal-00018540

<https://hal.science/hal-00018540v1>

Submitted on 7 Feb 2006 (v1), last revised 11 Jun 2014 (v2)

HAL is a multi-disciplinary open access archive for the deposit and dissemination of scientific research documents, whether they are published or not. The documents may come from teaching and research institutions in France or abroad, or from public or private research centers.

L'archive ouverte pluridisciplinaire **HAL**, est destinée au dépôt et à la diffusion de documents scientifiques de niveau recherche, publiés ou non, émanant des établissements d'enseignement et de recherche français ou étrangers, des laboratoires publics ou privés.

NONCOMMUTATIVE SYMMETRIC FUNCTIONS III: DEFORMATIONS OF CAUCHY AND CONVOLUTION ALGEBRAS

G erard DUCHAMP*, Alexander KLYACHKO[†],
Daniel KROB[‡] and Jean-Yves THIBON[§]

February 7, 2006

Abstract

This paper discusses various deformations of free associative algebras and of their convolution algebras. Our main examples are deformations of noncommutative symmetric functions related to families of idempotents in descent algebras, and a simple q -analogue of the shuffle product, which has unexpected connections with quantum groups, hyperplane arrangements, and certain questions in theoretical physics (the quon algebra).

* LIR, Universit  de Rouen, 76134 Mont Saint-Aignan Cedex, France – e-mail: ged@litp.ibp.fr

[†] Bilkent University, Ankara, Turkey – e-mail: klyachko@fen.bilkent.edu.tr

[‡] LITP (IBP, CNRS), Universit  Paris 7, 2, place Jussieu, 75251 Paris Cedex 05, France – e-mail: dk@litp.ibp.fr

[§] IGM, Universit  de Marne-la-Vall e, 2, rue de la Butte-Verte, 93166 Noisy-le-Grand Cedex, France – e-mail: jyt@litp.ibp.fr

1	Introduction	3
2	Noncommutative symmetric functions	6
2.1	Definitions	6
2.2	Relations with Solomon's descent algebra	7
2.3	Quasi-symmetric functions	7
2.4	Differences and products of alphabets	8
3	Deformations of Cauchy and convolution products	10
3.1	The general case	10
3.2	Deformations using noncommutative symmetric functions	14
4	The q-shuffle product	15
4.1	Definition	15
4.2	The operator $U(q)$	16
4.3	$U(q)$ in physics: the quon algebra	17
4.4	Zagier's inversion of $U(q)$	18
4.5	A representation theoretical interpretation of the q -shuffle	20
5	The q-shuffle Hopf algebra and its convolution algebra	25
5.1	The q -shuffle Hopf algebra	25
5.2	Primitive elements for c_q	26
5.3	The convolution algebra	28
6	Some generalizations of the shuffle operator	29
6.1	Rosso's quantum shuffles	29
6.2	Twisted derivations and multi-parameter deformations of the shuffle product	31
6.3	Shuffle operators in the braid group algebra	33
6.3.1	A shuffle element in the braid group algebra	33
6.3.2	Factorizations	33
6.3.3	Action of the braid group on words	35
6.4	Diagonal hyperplane arrangements	37
6.4.1	The quantum bilinear form B_n	37
6.4.2	A decomposition of B_n	39
6.5	The t -shuffle operator in the Hecke algebra	42
7	Deformations of the algebra of noncommutative symmetric functions	45
7.1	Deformations and Lie idempotents	45
7.2	Structure of the multihomogeneous modules associated with Lie idempotents	48
7.3	Structure of the modules associated with deformations of some classical Lie idempotents	51
7.3.1	$\Phi_n((1-q)A)$	51
7.3.2	$\Phi_n(A/(1-q))$	53
7.3.3	$\Psi_n((1-q)A)$	53
7.3.4	$\Psi_n(A/(1-q))$	54

This article is devoted to the investigation of certain deformations of free associative (or tensor) algebras and of their convolution algebras. Typically, the deformations we are interested in depend on one or several parameters and are trivial in the sense of the deformation theory of algebras. That is, for generic values of these parameters there exists a conjugating isomorphism

$$u \odot v = f(f^{-1}(u)f^{-1}(v))$$

between the deformed product \odot and the original one. However, for specific values of the parameters, the deformed product degenerates in a non-trivial way, a situation which allows for the representation of complicated algebras as limiting cases of well-understood ones.

The motivation for this investigation was provided by examples of direct sum decompositions of the free associative algebra $K\langle A \rangle$, regarded as the universal enveloping algebra of the free Lie algebra $L(A)$

$$K\langle A \rangle = \bigoplus_{\lambda} U_{\lambda} \tag{1}$$

analogous to the Poincaré-Birkhoff-Witt decomposition, *i.e.* λ runs through the set of all partitions, $U_0 = K$ and $U_1 = L(A)$.

In these examples, each module U_{λ} is the image of the homogeneous component $K\langle A \rangle_n$ of degree n of $K\langle A \rangle$ by a certain idempotent e_{λ} of the group algebra of the symmetric group $K[\mathfrak{S}_n]$, acting on the right by $(x_1 x_2 \cdots x_n) \cdot \sigma = x_{\sigma(1)} x_{\sigma(2)} \cdots x_{\sigma(n)}$ (where $x_i \in A$).

In the case of the Poincaré-Birkhoff-Witt decomposition, coming from the identification of $K\langle A \rangle$ with the symmetric algebra $S(L(A))$, U_{λ} is the subspace spanned by symmetrized products of Lie polynomials

$$(P_1, P_2, \dots, P_r) = \frac{1}{r!} \sum_{\sigma \in \mathfrak{S}_r} P_{\sigma(1)} P_{\sigma(2)} \cdots P_{\sigma(r)}$$

such that each P_i is homogeneous of degree λ_i . The corresponding idempotents, introduced by Garsia and Reutenauer [9], are refinements of the so called Eulerian idempotents (*cf.* [30]), which arise for example in the computation of the Hausdorff series [25], or in the study of the Hochschild cohomology of commutative algebras [13, 22].

The Garsia-Reutenauer idempotents e_{λ} form, taking all partitions of a given n , a complete set of orthogonal idempotents of a remarkable subalgebra Σ_n of $K[\mathfrak{S}_n]$, discovered by L. Solomon [36] and called the *descent algebra*. It has been shown in [20] that such complete sets can be constructed for all descent algebras from any sequence $e_{(n)}$ of *Lie idempotents* of Σ_n , *i.e.* idempotents projecting $K\langle A \rangle_n$ onto $L_n(A)$. In particular, using the deformation theory of noncommutative symmetric functions, one can obtain interesting sequences of Lie idempotents, depending on one or more parameters, and interpolating in a natural way between all known examples [6, 20]. This leads to various deformations of the Garsia-Reutenauer idempotents and of the Eulerian idempotents, and the first question is certainly to explicit the modules U_{λ} on which they project. The deformation technique presented in Section 3 provides the following answer (Section 7, Prop. 7.4):

There exists for each n a vector $p = (p_I)$ indexed by compositions of n , satisfying $\sum_I p_I = 1$, such that U_{λ} is spanned by the weighted symmetrized products

$$(P_1, P_2, \dots, P_r)_p = \sum_{\sigma \in \mathfrak{S}_r} p_{\lambda \cdot \sigma} P_{\sigma(1)} P_{\sigma(2)} \cdots P_{\sigma(r)}$$

The weights p_I are explicit for several interesting examples.

The only recorded example of decomposition (1) which does not come from a sequence of Lie idempotents in descent algebras is the so-called *orthogonal decomposition* (cf. [4]). It has been shown by Ree [28] that if one endows $K\langle A \rangle$ with the scalar product for which words form an orthonormal basis, the orthogonal complement of $L(A)$ is the space spanned by proper shuffles $u\sqcup v$, $u, v \neq 1$. The orthogonal Lie idempotent π_n is the orthogonal projector from $K\langle A \rangle_n$ onto $L_n(A)$. This idempotent is not in the descent algebra, and it would be of interest to understand its structure. The orthogonal decomposition of the $K\langle A \rangle$ can be refined into a decomposition of type (1), where U_λ is now spanned by shuffles of homogeneous Lie elements

$$P_1 \sqcup P_2 \sqcup \cdots \sqcup P_r$$

with each P_i of degree λ_i . The relationship between the projectors $\pi_n = e_{(n)}$ of this decomposition and the other projectors e_λ is somewhat analogous to the one encountered in the case of the descent algebra, but considerably more intricate.

To understand this analogy, we were led to introduce a q -analogue of the shuffle product, which, strictly speaking, is rather a deformation of the concatenation product (obtained for $q = 0$), recursively defined by

$$au \odot_q bv = a(u \odot_q bv) + q^{|au|} b(au \odot_q v) \quad (2)$$

where $a, b \in A$ and $u, v \in A^*$. This product degenerates at roots of unity, and in particular gives the standard (commutative) shuffle product for $q = 1$. We conjecture that its convolution algebra degenerates for $q \rightarrow 1$ into a commutative algebra which is associated with a Ree type decomposition

$$K\langle A \rangle = K \oplus L \oplus L \sqcup L \oplus \cdots$$

where L is a subspace which has the same Hilbert series as the free Lie algebra (this subspace can be explicit). A challenging problem would be to find a good deformation of the shuffle product giving the convolution algebra relevant to the case of the orthogonal idempotent as a degenerate case.

It turns out that the q -shuffle, as well as the elements $U_n(q) = \sum_{\sigma \in \mathfrak{S}_n} q^{\ell(\sigma)} \sigma$, which are naturally associated with it, already occurred in the literature, in several apparently unrelated contexts.

First of all, the q -shuffle algebra is the simplest non-trivial case of a very general construction due to M. Rosso, obtained in the context of the theory of quantum groups. Moreover, the q -shuffle algebra is isomorphic to the free associative algebra iff $U_n(q)$ is invertible for all n . The computation of its determinant (as an operator of the regular representation of \mathfrak{S}_n) already occurred in a problem of physics (the Hilbert space representability of the quon algebra, describing hypothetical particles violating Bose or Fermi statistics [15]), and was solved by D. Zagier who also computed $U_n(q)^{-1}$ by means of certain factorization formulas. Surprisingly enough, Zagier's formula for $\det U_n(q)$ turns out to be a special case of a recent formula of Varchenko [38], giving the determinant of what he calls the quantum bilinear form of a hyperplane arrangement. To complete the picture, we mention that the q -shuffle also has a natural interpretation within the representation theory of the 0-Hecke algebras of type A [7]. These aspects of the q -shuffle are reviewed, and the various connections are exploited in order to give generalizations or

struct a quantum shuffle from any solution of the Yang-Baxter equation (without spectral parameters), and that the Hall-Littlewood symmetric functions or the q -Fock spaces of Kashiwara, Miwa and Stern [18] can be regarded as examples of this construction. Also, we generalize Zagier's factorizations to identities in the algebra of the infinite braid group, and give some applications.

This paper is structured as follows. We first recall the basic definitions concerning noncommutative symmetric functions [10], which provide the convenient formalism for computing in convolution algebras (Section 2). Next, we present a general deformation pattern and give some simple properties (Section 3). In Section 4 we introduce the q -shuffle and derive its fundamental properties. We review the quon algebra, the work of Zagier, and give some details on the interpretation in terms of the 0-Hecke algebra. In Section 5, we study the q -shuffle algebra as a Hopf algebra, and present our conjecture concerning the limit $q \rightarrow 1$ of its convolution algebra. In Section 6, we give a simplified presentation of Rosso's quantum shuffles and exhibit some new examples. Next, we generalize to the braid group some of the formulas which occurred in the study of the q -shuffle, explain the connection with Varchenko's construction, and illustrate the general results on an example constructed from the standard Hecke-type solution of the Yang-Baxter equation. Finally, Section 7 is devoted to the description of the decompositions of the free associative algebra obtained from deformations of the Garsia-Reutenauer idempotents.

ACKNOWLEDGEMENTS — The authors are grateful to R. Stanley for communicating Varchenko's reference [38] and to D. Zagier for interesting conversations concerning his work [40].

2.1 Definitions

The algebra of *noncommutative symmetric functions*, defined in [10], is the free associative algebra $\mathbf{Sym} = \mathbb{Q}\langle S_1, S_2, \dots \rangle$ generated by an infinite sequence of noncommutative indeterminates S_k , called the *complete symmetric functions*. We set for convenience $S_0 = 1$. Let t be another variable commuting with all the S_k . Introducing the generating series

$$\sigma(t) := \sum_{k=0}^{\infty} S_k t^k ,$$

one defines other families of noncommutative symmetric functions by the following relations

$$\lambda(t) = \sigma(-t)^{-1} ,$$

$$\frac{d}{dt} \sigma(t) = \sigma(t) \psi(t) , \quad \sigma(t) = \exp(\Phi(t)) ,$$

where $\lambda(t)$, $\psi(t)$ and $\phi(t)$ are the generating series

$$\lambda(t) := \sum_{k=0}^{\infty} \Lambda_k t^k$$

$$\psi(t) := \sum_{k=1}^{\infty} \Psi_k t^{k-1} , \quad \Phi(t) := \sum_{k=1}^{\infty} \frac{\Phi_k}{k} t^k .$$

The noncommutative symmetric functions Λ_k are called *elementary functions*, and Ψ_k and Φ_k are respectively called *power sums* of *first* and *second kind*.

The algebra \mathbf{Sym} is graded by the weight function w defined by $w(S_k) = k$. Its homogeneous component of weight n is denoted by \mathbf{Sym}_n . If (F_n) is a sequence of noncommutative symmetric functions with $F_n \in \mathbf{Sym}_n$ for $n \geq 1$, we set for a composition $I = (i_1, \dots, i_r)$

$$F^I = F_{i_1} F_{i_2} \dots F_{i_r} .$$

The families (S^I) , (Λ^I) , (Ψ^I) and (Φ^I) are homogeneous bases of \mathbf{Sym} .

The algebra \mathbf{Sym} can also be endowed with a Hopf algebra structure. Its coproduct Δ is defined by any of the following equivalent formulas:

$$\Delta(S_n) = \sum_{k=0}^n S_k \otimes S_{n-k} , \quad \Delta(\Lambda_n) = \sum_{k=0}^n \Lambda_k \otimes \Lambda_{n-k} ,$$

$$\Delta(\Psi_n) = 1 \otimes \Psi_n + \Psi_n \otimes 1 , \quad \Delta(\Phi_n) = 1 \otimes \Phi_n + \Phi_n \otimes 1 .$$

The free Lie algebra $L(\Phi)$ generated by the family $(\Phi_n)_{n \geq 1}$ is then the Lie algebra of primitive elements for Δ .

The set of all compositions of a given integer n is equipped with the *reverse refinement order*, denoted \preceq . For instance, the compositions J of 4 such that $J \preceq (1, 2, 1)$ are exactly $(1, 2, 1)$, $(3, 1)$, $(1, 3)$ and (4) . The *ribbon Schur functions* (R_I) , originally defined in terms of quasi-determinants (*cf.* [11, 12]), can also be defined by one of the two equivalent relations

$$S^I = \sum_{J \preceq I} R_J , \quad R_I = \sum_{J \preceq I} (-1)^{\ell(I) - \ell(J)} S^J ,$$

(R_I) is a homogenous basis of \mathbf{Sym} .

The commutative image of a noncommutative symmetric function F is the (commutative) symmetric function f obtained by applying to F the algebra morphism which maps S_n onto h_n (using here the notations of Macdonald's book [23]). The commutative image of Λ_n is e_n and the power sums Ψ_n and Φ_n are both mapped to p_n . Finally R_I is sent to an ordinary ribbon Schur function, which will be denoted by r_I .

2.2 Relations with Solomon's descent algebra

There is a noncommutative analog of the well known correspondence between symmetric functions and characters of symmetric groups, where the character ring of a symmetric group is replaced by the descent algebra, in the sense of Solomon [36]. Recall that an integer $i \in [1, n-1]$ is said to be a *descent* of a permutation $\sigma \in \mathfrak{S}_n$ iff $\sigma(i) > \sigma(i+1)$. The *descent set* of a permutation $\sigma \in \mathfrak{S}_n$ is the subset of $[1, n-1]$ consisting of all descents of σ . If $I = (i_1, \dots, i_r)$ is a composition of n , one associates with it the subset $D(I) = \{d_1, \dots, d_{r-1}\}$ of $[1, n-1]$ defined by $d_k = i_1 + \dots + i_k$. Let D_I be the sum in $\mathbb{Z}[\mathfrak{S}_n]$ of all permutations with descent set $D(I)$. Solomon showed that the D_I form a basis of a subalgebra of $\mathbb{Z}[\mathfrak{S}_n]$ which is called the *descent algebra* of \mathfrak{S}_n and denoted by Σ_n [36]. One can define an isomorphism of graded vector spaces

$$\alpha : \mathbf{Sym} = \bigoplus_{n=0}^{\infty} \mathbf{Sym}_n \longrightarrow \Sigma = \bigoplus_{n=0}^{\infty} \Sigma_n$$

by

$$\alpha(R_I) = D_I .$$

The direct sum Σ can be endowed with an algebra structure by extending the natural product of its components Σ_n , setting $xy = 0$ for $x \in \Sigma_p$ and $y \in \Sigma_q$ when $p \neq q$. The *internal product* $*$ on \mathbf{Sym} is then defined by requiring that α be an *anti*-isomorphism, *i.e.* by

$$F * G = \alpha^{-1}(\alpha(G) \circ \alpha(F)) ,$$

for $F, G \in \mathbf{Sym}$. The fundamental property for computing with the internal product is the following formula:

Proposition 2.1 [10] *Let F_1, F_2, \dots, F_r, G be noncommutative symmetric functions. Then,*

$$(F_1 F_2 \dots F_r) * G = \mu_r[(F_1 \otimes F_2 \otimes \dots \otimes F_r) * \Delta^r(G)]$$

where in the right-hand side, μ_r denotes the r -fold ordinary multiplication and $*$ stands for the operation induced on $\mathbf{Sym}^{\otimes n}$ by $*$.

2.3 Quasi-symmetric functions

As shown by Malvenuto and Reutenauer [24], the algebra of noncommutative symmetric functions is in natural duality with the algebra of quasi-symmetric functions, introduced by Gessel [14].

Let $X = \{x_1, x_2, \dots, x_n \dots\}$ be a totally ordered infinite alphabet (indexed by \mathbb{N}). An element $f \in \mathbb{C}[X]$ is said to be a *quasi-symmetric function* iff for any composition

one has

$$(f | y_1^{k_1} y_2^{k_2} \dots y_m^{k_m}) = (f | z_1^{k_1} z_2^{k_2} \dots z_m^{k_m})$$

where $(f, |x^K)$ denotes the coefficient of the monomial x^K in f . The quasi-symmetric functions form a subalgebra of $\mathbb{C}[X]$ denoted by $QSym$.

One associates to a composition $I = (i_1, i_2, \dots, i_m)$ the *quasi-monomial function* M_I defined by

$$M_I = \sum_{y_1 < y_2 < \dots < y_m} y_1^{i_1} y_2^{i_2} \dots y_m^{i_m} .$$

The family of quasi-monomial functions is clearly a basis of $QSym$. Another important basis of $QSym$ is formed by the *quasi-ribbon functions*, defined by

$$F_I = \sum_{J \succeq I} M_J$$

where \succeq is the refinement order (*i.e.* $J \succeq I$ iff $D(J) \supseteq D(I)$). For example, $F_{122} = M_{122} + M_{1112} + M_{1211} + M_{11111}$.

The duality between **Sym** and $QSym$ is realized by the pairing

$$\langle S^I, M_J \rangle = \delta_{I,J} \quad \text{or} \quad \langle R_I, F_J \rangle = \delta_{I,J} .$$

The Hopf algebra $QSym$ can then be identified with the (graded) Hopf algebra dual of **Sym**.

2.4 Differences and products of alphabets

We recall here some basic definitions concerning transformations of alphabets. We refer to [20] for more details. The basic idea is to embed noncommutative symmetric functions in a noncommutative polynomial algebra (for example by defining $\sigma(A; t) = \prod_{i \geq 1} (1 - ta_i)^{-1}$ for some noncommutative alphabet A), and then to regard the images of the generators $S_n(A)$ by an algebra morphism as being the symmetric functions $S_n(A')$ of another alphabet A' , which can sometimes be explicited, but may also be virtual. For example, the formal difference of two genuine alphabets A and B is generally only a virtual alphabet, having nevertheless well-defined symmetric functions, expressible in terms of those of A and B .

We first recall the definition of the product of a totally ordered alphabet by a noncommutative alphabet.

Definition 2.2 *Let X be a totally ordered commutative alphabet and let A be a noncommutative alphabet. The complete symmetric functions $S_n(XA)$ of the alphabet XA are defined by the generating series*

$$\sigma(XA; t) = \sum_{n \geq 0} S_n(XA) t^n := \prod_{x \in X} \sigma(A; xt) ,$$

the product being taken relatively to the total ordering of X .

Example 2.3 Let $X_q = 1/(1 - q)$ denote the totally ordered alphabet $X_q = \{ \dots < q^n < \dots < q < 1 \}$. The complete symmetric functions of the alphabet $A/(1 - q)$ are

$$\sigma\left(\frac{A}{1 - q}; t\right) = \sum_{n \geq 0} S_n\left(\frac{A}{1 - q}\right) t^n := \overleftarrow{\prod}_{n \geq 0} \sigma(A; q^n t) .$$

Proposition 2.4 *Let X, Y be two totally ordered commutative alphabets and let A be a noncommutative alphabet. Then, for any F_n of \mathbf{Sym}_n ,*

$$F_n((X \times Y)A) = F_n(XA) * S_n(YA) ,$$

where $X \times Y$ denotes the direct product of the two alphabets X and Y endowed with the lexicographic ordering.

This property suggests the notation $S_n(A/X)$ for the $*$ -inverse of $S_n(XA)$ in \mathbf{Sym}_n . Finally, here is the definition of the difference of two noncommutative alphabets.

Definition 2.5 *Let A, B be two noncommutative alphabets. The complete symmetric functions $S_n(A - B)$ of the alphabet $A - B$ are defined by the generating series*

$$\sigma(A - B; t) = \sum_{n \geq 0} S_n(A - B) t^n := \sigma(B; t)^{-1} \sigma(A; t) = \lambda(B; -t) \sigma(A; t) .$$

The notation $(1 - q)A = A - qA$ denotes therefore the alphabet whose complete symmetric functions are

$$\sigma((1 - q)A; t) = \sum_{n \geq 0} S_n((1 - q)A) t^n := \lambda(A; -qt) \sigma(A; t) .$$

These notations are coherent since it can be checked that $S_n((1 - q)A)$ is actually the inverse of $S_n(A/(1 - q))$ in \mathbf{Sym}_n for the internal product.

In the sequel, K will denote a field of characteristic 0, and A will always be an infinite alphabet whose letters are indexed by \mathbb{N} , *i.e.* $A = \{a_1, a_2, \dots, a_n, \dots\}$.

3.1 The general case

Consider, for all $n \geq 1$, an invertible element

$$\beta_n = \sum_{\sigma \in \mathfrak{S}_n} b_\sigma^{(n)} \sigma \in K[\mathfrak{S}_n].$$

We require that $\beta_1 = Id_{\mathfrak{S}_1}$. This data defines a linear operator β on $K\langle A \rangle$ by

$$\beta(a_{i_1} \dots a_{i_n}) = a_{i_1} \dots a_{i_n} \cdot \beta_n = \sum_{\sigma \in \mathfrak{S}_n} b_\sigma^{(n)} a_{i_{\sigma(1)}} \dots a_{i_{\sigma(n)}}$$

where $a_{i_1}, \dots, a_{i_n} \in A$.

This allows us to equip $K\langle A \rangle$ with a new product \odot_β , defined by

$$u \odot_\beta v = \beta(\beta^{-1}(u) \cdot \beta^{-1}(v)) \quad (3)$$

for u, v of A^* . In other terms, this product is defined in such a way that β becomes an isomorphism of algebras between $K\langle A \rangle$ equipped with its usual concatenation (or Cauchy) product and $K\langle A \rangle$ equipped with the new product \odot_β .

Thus, $(K\langle A \rangle, \odot_\beta)$ is a free associative algebra on $\beta(A) = \beta_1(A) = A$. It is therefore endowed with a canonical comultiplication c_β , defined by

$$c_\beta(a) = 1 \otimes a + a \otimes 1$$

for $a \in A$, and by the requirement that c_β is an algebra morphism for \odot_β .

Let $\mathcal{C}_\beta(A)$ be the convolution algebra of the Hopf algebra $(K\langle A \rangle, \odot_\beta, c_\beta)$, that is, $\mathcal{C}_\beta(A) = \text{End}^{\text{gr}} K\langle A \rangle$ endowed with the convolution product

$$f \otimes_\beta g = \mu_\beta \circ (f \otimes g) \circ c_\beta \quad (4)$$

where $\mu_\beta : u \otimes v \mapsto u \odot_\beta v$ is the multiplication. When $\beta = I$, it is well known that the direct sum of the group algebras of all symmetric groups

$$K[\mathfrak{S}] = \bigoplus_{n \geq 0} K[\mathfrak{S}_n] \quad (5)$$

is a subalgebra of the convolution algebra (*cf.* [30]). This is also true for the β -deformed products.

Proposition 3.1 *The β -convolution algebra $(K[\mathfrak{S}], \otimes_\beta)$ is isomorphic to the usual convolution algebra $(K[\mathfrak{S}], \otimes)$ (which corresponds to the case where β is the identity).*

Proof — Let c be the comultiplication of $K\langle A \rangle$ (for its usual Cauchy structure) making letters primitive. By definition of \odot_β ,

$$\beta(a_1 \dots a_n) = a_1 \odot_\beta \dots \odot_\beta a_n$$

$$\begin{array}{ccc}
K\langle A \rangle & \xrightarrow{\beta} & K\langle A \rangle \\
\downarrow c & & \downarrow c_\beta \\
K\langle A \rangle \otimes K\langle A \rangle & \xrightarrow{\beta \otimes \beta} & K\langle A \rangle \otimes K\langle A \rangle
\end{array}$$

In other words, $c_\beta = (\beta \otimes \beta) \circ c \circ \beta^{-1}$, so that

$$\begin{aligned}
\sigma \otimes_\beta \tau &= \odot_\beta \circ (\sigma \otimes \tau) \circ c_\beta \\
&= \beta \circ \odot \circ (\beta^{-1} \otimes \beta^{-1}) \circ (\sigma \otimes \tau) \circ (\beta \otimes \beta) \circ c \circ \beta^{-1} \\
&= \beta \circ \odot \circ \left((\beta^{-1} \circ \sigma \circ \beta) \otimes (\beta^{-1} \circ \tau \circ \beta) \right) \circ c \circ \beta^{-1}
\end{aligned}$$

where we identify an element x of $K[\mathfrak{S}]$ with the endomorphism corresponding to its left action $y \longrightarrow x \circ y$ on $K[\mathfrak{S}]$ (\odot denotes here the usual concatenation product of $K\langle A \rangle$). Consider now the bijection f_β from $K[\mathfrak{S}]$ into itself defined by

$$f_\beta(\sigma) = \beta_n \circ \sigma \circ \beta_n^{-1}$$

for $\sigma \in \mathfrak{S}_n$. We have just proved that

$$f_\beta(\sigma \otimes_\beta \tau) = f_\beta(\sigma) \otimes f_\beta(\tau), \quad (6)$$

and f_β is the required isomorphism. \square

Note 3.2 The definition of β shows that

$$\sigma \circ \beta(\tau) = \beta(\sigma \circ \tau)$$

for any two permutations σ and τ . This just means that the left and right actions of the symmetric group commute. One can then easily check that

$$\sigma \otimes_\beta \tau = \beta(\sigma \otimes \tau) \quad (7)$$

for permutations σ and τ of arbitrary orders.

Consider now the subalgebra Σ_β of $(K[\mathfrak{S}], \otimes_\beta)$ which is generated by all the elements $Id_n = 12 \dots n$ for every $n \geq 0$. When β is the identity of $K\langle A \rangle$, Σ_β is isomorphic to the direct sum Σ of all descent algebras equipped with the convolution product (*cf.* [30]), hence to the algebra of noncommutative symmetric functions (*cf.* Section 2). An explicit isomorphism between these algebras is given by

$$S_{i_1} S_{i_2} \dots S_{i_n} \longrightarrow Id_{i_1} \otimes Id_{i_2} \otimes \dots \otimes Id_{i_n}.$$

One can deform this isomorphism by constructing a new isomorphism denoted α_β from **Sym** into Σ_β which maps the complete function S^I (where $I = (i_1, \dots, i_n)$ is a composition) to the convolution product

$$Id_{i_1} \otimes_\beta Id_{i_2} \otimes_\beta \dots \otimes_\beta Id_{i_n}.$$

It is interesting to observe that the isomorphism α_β can be seen as a deformation of the classical interpretation α of noncommutative symmetric functions into Solomon's descent algebra. One can therefore obtain by this method different interpretations of noncommutative symmetric functions. The following result gives an explicit expression for the deformed interpretation map α_β .

$$\alpha_\beta(F_n) = \beta_n^{-1} \circ \alpha(F_n) \circ \beta_n . \quad (8)$$

Proof — With the same notations as in the proof of Proposition 3.1, one has

$$f_\beta(\alpha_\beta(S^I)) = f_\beta(\text{Id}_{i_1} \otimes_\beta \dots \otimes_\beta \text{Id}_{i_n}) = f_\beta(\text{Id}_{i_1}) \otimes \dots \otimes f_\beta(\text{Id}_{i_n}) = \alpha(S^I)$$

according to (6) and to the fact that $f_\beta(\text{Id}_k) = \text{Id}_k$ for every $k \geq 0$. Hence, $f_\beta(\alpha_\beta(S^I)) = \alpha(S^I)$. That is, $\alpha_\beta(S^I) = \beta_n^{-1} \circ \alpha(S^I) \circ \beta_n$. \square

As an immediate consequence, we can state:

Corollary 3.4 *The convolution algebra Σ_β is a subalgebra of $K[\mathfrak{S}]$ equipped with the usual composition product.*

Proof — Let x and y be two homogenous elements of the same order n of Σ_β . By construction, there exists two elements f and g of \mathbf{Sym}_n such that $x = \alpha_\beta(f)$ and $y = \alpha_\beta(g)$. It follows then from Proposition 3.3 that

$$\begin{aligned} x \circ y &= (\beta_n^{-1} \circ \alpha(f) \circ \beta_n) \circ (\beta_n^{-1} \circ \alpha(g) \circ \beta_n) \\ &= \beta_n^{-1} \circ \alpha(f) \circ \alpha(g) \circ \beta_n \\ &= \beta_n^{-1} \circ \alpha(g * f) \circ \beta_n \\ &= \alpha_\beta(g * f) \in \Sigma_\beta . \end{aligned}$$

\square

Note 3.5 The proof of the corollary shows that

$$\alpha_\beta(F) \circ \alpha_\beta(G) = \alpha_\beta(G * F)$$

for homogenous elements F, G of the same weight of \mathbf{Sym} . It follows in particular that the image by α_β of a homogenous idempotent of \mathbf{Sym} (for the internal product) is still an idempotent in Σ_β .

Example 3.6 Let us explicit the interpretation of the image by α_β of the Eulerian idempotent ϕ_n (which is the image by α of the element Φ_n/n of \mathbf{Sym}_n). Let \mathcal{L} denote the image of the free Lie algebra $L(A)$ by β . Transporting by β the Poincaré-Birkhoff-Witt decomposition of $K\langle A \rangle$, we obtain

$$K\langle A \rangle = K \oplus \mathcal{L} \oplus (\mathcal{L}, \mathcal{L})_\beta \oplus \dots \oplus \underbrace{(\mathcal{L}, \dots, \mathcal{L})_\beta}_{n \text{ terms}} \oplus \dots$$

where

$$(x_1, \dots, x_n)_\beta = \frac{1}{n!} \left(\sum_{\sigma \in \mathfrak{S}_n} x_{\sigma(1)} \odot_\beta \dots \odot_\beta x_{\sigma(n)} \right)$$

for $x_1, \dots, x_n \in K\langle A \rangle$. Then, $\alpha_\beta(\Phi_n/n) = \beta_n \circ \phi_n \circ \beta_n$ is the idempotent corresponding to the projection of the homogenous component of degree n of \mathcal{L} with respect to the above direct sum decomposition of $K\langle A \rangle$.

q and are invertible for generic values of q . In such situations, the convolution algebra $\Sigma_\beta(q)$ degenerates when q takes a value q_0 for which $\beta = \beta(q)$ is not an isomorphism. We will however still use the notation $\Sigma_\beta(q_0)$ to denote the limit of $\Sigma_\beta(q)$ for $q \rightarrow q_0$ whenever it exists. Several interesting problems arise in the investigation of these degenerate convolution algebras.

Note 3.8 The framework presented here can be easily generalized to some other situations. Among them is the case of the so-called *orthogonal Lie idempotent* (see [4, 30]). The orthogonal Lie idempotent π_n is the idempotent of $\mathbb{Q}[\mathfrak{S}_n]$ which corresponds to the orthogonal projection from $K\langle A \rangle$ (endowed with its standard scalar product for which words form an orthonormal basis) onto the homogenous component $L(A)_n$ of order n of the free Lie algebra $L(A)$. π_n is also the projection onto $L(A)_n$ with respect to the decomposition of $K\langle A \rangle$ given by Ree's theorem, *i.e.*

$$K\langle A \rangle = K \oplus L(A) \oplus L(A) \sqcup L(A) \oplus \dots \oplus \underbrace{L(A) \sqcup \dots \sqcup L(A)}_{n \text{ terms}} \oplus \dots$$

where \sqcup denotes the usual shuffle product on $\mathbb{Q}\langle A \rangle$.

Let \mathcal{B} be any linear basis of $L(A)$. The shuffle algebra $(\mathbb{Q}\langle A \rangle, \sqcup)$ is a free commutative algebra with \mathcal{B} as generating family (*cf.* [30]). This property allows us to define a comultiplication c_\sqcup on $\mathbb{Q}\langle A \rangle$ by

1. $c_\sqcup(L) = 1 \otimes L + L \otimes 1$ for every Lie element $L \in L(A)$;
2. $c_\sqcup(P \sqcup Q) = c_\sqcup(P) (\sqcup \otimes \sqcup) c_\sqcup(Q)$ for every polynomials $P, Q \in \mathbb{Q}\langle A \rangle$.

One can then consider the associated convolution product \otimes_\sqcup on $\mathbb{Q}[\mathfrak{S}]$, defined by

$$\sigma \otimes_\sqcup \tau = \sqcup \circ (\sigma \otimes \tau) \circ c_\sqcup(1 \ 2 \ \dots \ n+m)$$

for $\sigma \in \mathfrak{S}_n$ and $\tau \in \mathfrak{S}_m$. The commutativity of the shuffle product implies the cocommutativity of c_\sqcup . Hence the convolution algebra $(\mathbb{Q}[\mathfrak{S}], \otimes_\sqcup)$ is here commutative. It follows that its subalgebra Σ_\sqcup generated by the identity elements of all symmetric groups is also commutative. Consider now the morphism from *Sym* into Σ_\sqcup defined as in the general case by

$$\alpha_\sqcup(S^{(i_1, \dots, i_n)}) = Id_{i_1} \otimes_\sqcup \dots \otimes_\sqcup Id_{i_n} .$$

This is a degenerate situation in which the image by α_\sqcup of the algebra of noncommutative symmetric functions is not isomorphic to Solomon's descent algebra. The generic interpretation of the image by α_\sqcup of the Eulerian idempotent Φ_n given in Example 3.6 is however still valid here. It follows from this interpretation that Ree's decomposition is equivalent to

$$\alpha_\sqcup(\Phi_n) = \pi_n .$$

It follows that π_n belongs to the homogenous component $\Sigma_\sqcup^{(n)}$ of order n of Σ . It is easy to see that this set is a subalgebra of $K[\mathfrak{S}_n]$ of dimension $p(n)$ (the number of partitions of n). An interesting research direction would be to characterize this subalgebra and to give explicit formulas for the images of the standard bases of **Sym** by α_\sqcup . The decomposition of π_n on such bases would then be immediately given by decomposition relations of Φ_n in **Sym**.

descent algebra $\Sigma_2 = \mathbb{Q}[\mathfrak{S}_2]$. In the second case, $\Sigma_{\mathfrak{u}}^{(\mathfrak{u})}$ is the commutative algebra spanned by

$$\alpha_{\mathfrak{u}}(R_3) = 123, \quad \alpha_{\mathfrak{u}}(R_{12}) = \alpha_{\mathfrak{u}}(R_{21}) = \frac{1}{2}(132 + 213 + 231 + 312), \quad \alpha_{\mathfrak{u}}(R_{111}) = 321,$$

and the orthogonal projector is

$$\pi_3 = \alpha_{\mathfrak{u}}(\Phi_3) = \alpha_{\mathfrak{u}}\left(R_3 - \frac{1}{2}R_{21} - \frac{1}{2}R_{12} + R_{111}\right) = 123 - \frac{1}{2}(132 + 213 + 231 + 312) + 321.$$

It is also interesting to see that the image by $\alpha_{\mathfrak{u}}$ of the homogenous component $L_n(\Psi)$ of order n of the free Lie algebra $L(\Psi) \subset \mathbf{Sym}$ generated by the family $(\Psi_n)_{n \geq 1}$ (or equivalently by the family $(\Phi_n)_{n \geq 1}$) collapses here onto a line, which is necessarily equal to $\mathbb{Q}\pi_n$.

3.2 Deformations using noncommutative symmetric functions

Here is an interesting special case of the previous constructions. Let $F = (F_n)_{n \geq 1}$ be a family of elements of \mathbf{Sym}_n , with $F_1 = S_1$. We assume that every F_n is invertible for the internal product of \mathbf{Sym}_n . We can then consider the bijection β_n defined by

$$\beta_n = \alpha(F_n),$$

where we identify an element of $K[\mathfrak{S}_n]$ with the linear morphism defined by its right action. In other words, β_n is given by

$$\beta_n : x \in K[\mathfrak{S}_n] \longrightarrow x \circ \alpha(F_n).$$

Denote by \odot_F the product of $K\langle A \rangle$ associated with the family $(\beta_n)_{n \geq 1}$ by the above construction. We also denote by \otimes_F and α_F the corresponding convolution product and interpretation morphism (of \mathbf{Sym} into the convolution algebra $\Sigma_F = \Sigma_\beta$).

Note first that Proposition 3.3 shows that the image of α_F is here exactly Solomon's descent algebra. Using α^{-1} , we can therefore reinterpret the convolution product \otimes_F . Formula (7) shows in particular that the algebra (Σ, \otimes_F) is isomorphic to the algebra of noncommutative symmetric functions endowed with the F -product defined by

$$U *_F V = F_{n+m} * (UV)$$

for homogenous elements U and V of weight n and m respectively. Identifying again $\alpha(U)$ with U and applying Proposition 3.3, one has

$$\alpha_F(U) = F_n * U * F_n^{*(-1)}$$

for $U \in \mathbf{Sym}_n$, where $F_n^{*(-1)}$ denotes the inverse of F_n for the internal product of \mathbf{Sym}_n .

We will study in the final Section of this paper the situations corresponding to the families given by the q -bracketing and its inverse, *i.e.* the cases $F_n = S_n((1-q)A)$ and $F_n = S_n(A/(1-q))$.

We present in this section the q -shuffle product which is an interesting deformation of the usual Cauchy product in $K\langle A \rangle$. We first give the formal definition of this product and then show that this deformation is a special case of the general framework introduced in Section 3.

4.1 Definition

The shuffle product can be recursively defined by the formula

$$au \sqcup bv = a(u \sqcup bv) + b(au \sqcup v) \quad (9)$$

where $a, b \in A$ and $u, v \in A^*$. Inserting a power of an indeterminate q in this definition, one obtains an interesting deformation, which turns out to be a particular case of a construction of Rosso [31].

Definition 4.1 *The q -shuffle product is the bilinear operation \odot_q on $\mathbb{N}[q]\langle A \rangle$ recursively defined by*

$$1 \odot_q u = u \odot_q 1 = u, \quad (10)$$

$$(au) \odot_q (bv) = a(u \odot_q bv) + q^{|au|} b(au \odot_q v), \quad (11)$$

where u, v (resp. a, b) are words (resp. letters) of A^* (resp. A).

This operation interpolates between the concatenation product (for $q = 0$) and the usual shuffle product (for $q = 1$) on $\mathbb{N}[q]\langle A \rangle$. The following property is a particular case of a result proved in Section 6.

Proposition 4.2 *The q -shuffle product is associative.*

□

As an exercise, let us check it directly. It is clearly sufficient to prove that

$$(au \odot_q bv) \odot_q cw = au \odot_q (bv \odot_q cw) \quad (12)$$

for $u, v, w \in A^*$ and $a, b, c \in A$. Applying (11), one finds

$$\begin{aligned} (au \odot_q bv) \odot_q cw &= a(u \odot_q bv) \odot_q cw + q^{|au|} b(au \odot_q v) \odot_q cw \\ &= a((u \odot_q bv) \odot_q cw) + q^{|au|+|bv|} c(a(u \odot_q bv) \odot_q w) \\ &\quad + q^{|au|} b((au \odot_q v) \odot_q cw) + q^{2|au|+|bv|} c(b(au \odot_q v) \odot_q w) \\ &= a((u \odot_q bv) \odot_q cw) + q^{|au|} b((au \odot_q v) \odot_q cw) \\ &\quad + q^{|au|+|bv|} c((a(u \odot_q bv) + q^{|au|} b(au \odot_q v)) \odot_q w). \end{aligned}$$

so that

$$\begin{aligned} (au \odot_q bv) \odot_q cw &= a((u \odot_q bv) \odot_q cw) \\ &\quad + q^{|au|} b((au \odot_q v) \odot_q cw) + q^{|au|+|bv|} c((au \odot_q bv) \odot_q w). \end{aligned} \quad (13)$$

On the other hand,

$$\begin{aligned} au \odot_q (bv \odot_q cw) &= au \odot_q (b(v \odot_q cw) + q^{|bv|} c(bv \odot_q w)) \\ &= a(u \odot_q b(v \odot_q cw)) + q^{|au|} b(au \odot_q (v \odot_q cw)) \\ &\quad + q^{|bv|} a(u \odot_q c(bv \odot_q w)) + q^{|au|+|bv|} c(au \odot_q (bv \odot_q w)) \\ &= a(u \odot_q (b(v \odot_q cw) + q^{|bv|} c(bv \odot_q w))) \\ &\quad + q^{|au|} b(au \odot_q (v \odot_q cw)) + q^{|au|+|bv|} c(au \odot_q (bv \odot_q w)). \end{aligned}$$

$$\begin{aligned}
au \odot_q (bv \odot_q cw) &= a(u \odot_q (bv \odot_q cw)) \\
&+ q^{|au|} b(au \odot_q (v \odot_q cw)) + q^{|au|+|bv|} c(au \odot_q (bv \odot_q w)) ,
\end{aligned} \tag{14}$$

which implies the result by induction.

4.2 The operator $U(q)$

As already observed, the q -shuffle can also be interpreted as a deformation (in the sense of the deformation theory of algebras) of the concatenation product of a free associative algebra. It is known that these algebras are rigid, which implies that for generic q the q -shuffle product is necessarily a deformation of the concatenation product in the sense of Section 3. It is easy to exhibit the conjugation isomorphism. Let $U(q)$ be the endomorphism of $\mathbb{Z}(q)\langle A \rangle$ defined by

$$U(q)(a_1 a_2 \dots a_n) = a_1 \odot_q a_2 \odot_q \dots \odot_q a_n$$

for $w = a_1 a_2 \dots a_n$ of A^* . The product \odot_q being multihomogeneous, the restriction of $U(q)$ to $\mathbb{Z}(q)\langle A \rangle_\lambda$ defines an endomorphism $U(q)_\lambda$ of $\mathbb{Z}(q)\langle A \rangle_\lambda$ for each multidegree λ , and one can write

$$U(q) = \bigoplus_{\lambda} U(q)_\lambda .$$

Moreover $U(q)$ clearly commutes with letter to letter substitutions. This shows that one can recover $U(q)$ from its restriction to standard words $U(q)_{1^n}$. This endomorphism corresponds to the right action of an element $U_n(q)$ of $\mathbb{Z}[q][\mathfrak{S}_n]$, which is given by the following formula.

Proposition 4.3

$$U_n(q)(12 \dots n) = 1 \odot_q 2 \odot_q \dots \odot_q n = \sum_{\sigma \in \mathfrak{S}_n} q^{\ell(\sigma)} \sigma . \tag{15}$$

This formula follows by induction from the following one, itself established by induction:

Lemma 4.4

$$12 \dots n-1 \odot_q n = \sum_{i=0}^{n-1} q^{n-1-i} (1 \dots i \ n \ i+1 \dots n-1) . \tag{16}$$

□

It follows that for a word of length n ,

$$U(q)(a_1 a_2 \dots a_n) = a_1 a_2 \dots a_n \cdot U_n(q)$$

and one sees that the q -shuffle is a deformation of the Cauchy product in the sense of Section 3 whenever $U_n(q)$ is a bijection.

Indeed, $\det U_n(q)$ is an analytic function of q , and $U_n(0)$ being the identity of $\mathbb{Z}[\mathfrak{S}_n]$, $U_n(q)$ is invertible for small complex values of q , and thus also for generic q (that is, for q an indeterminate, or for q a complex number avoiding a discrete set of values). It follows that $U(q)$ itself is also generically invertible and hence that the q -shuffle is generically a deformation of the Cauchy product in the sense of Section 3. One can restate this result as follows.

Equivalently, when $U(q)$ is invertible,

$$x \odot_q y = U(q) (U(q)^{-1}(x) \cdot U(q)^{-1}(y)) . \quad (17)$$

4.3 $U(q)$ in physics: the quon algebra

The problem arises now of finding the values of q for which $U_n(q)$ is actually invertible. It turns out that this problem has already been solved by D. Zagier [40] in a totally different context. The starting point was a problem in physics, related to a model of quantum field theory allowing the existence of particles (“*quons*”) displaying small violations of Bose or Fermi statistics [15]. Classically, bosons and fermions are described by creation and annihilation operators a_i, a_j^* satisfying canonical commutation or anticommutation relations. Here, the problem was to determine whether it was possible to realize the q -commutator (“ q -mutator”) relations

$$a_i a_j^* - q a_j^* a_i = \delta_{i,j} \quad (i, j \geq 1) \quad (18)$$

by operators a_i, a_j^* of a Hilbert space H , such that a_i^* be the adjoint of a_i , and such that there exists a distinguished vector $|0\rangle \in H$ (the vacuum state) annihilated by all the a_i

$$a_i |0\rangle = 0 \quad \text{for all } i . \quad (19)$$

D. Zagier proved the realizability of this model for $-1 < q < 1$ (another proof appears in [8]). It is easy to see that the realizability problem can be reduced to the case where H is equal to the vector space $H(q)$ generated by the images of $|0\rangle$ under all products of a_k and a_k^* . This space has a basis consisting of all states

$$|K\rangle = a_{k_1}^* \dots a_{k_n}^* |0\rangle$$

for $K = (k_1, \dots, k_n) \in (\mathbb{N}^*)^n$. Consider now the infinite matrix $A(q)$ defined by

$$A(q) = (\langle K|L \rangle)_{K,L \in (\mathbb{N}^*)^n, n \geq 0} ,$$

where the scalar product is defined by the condition $\langle 0|0\rangle = 1$. The Hilbert space realizability of relations (18) is equivalent to the positive definiteness of the matrix $A(q)$. Moreover, one can prove that this condition is equivalent to the positive definiteness of all submatrices of $A(q)$ indexed by permutations of \mathfrak{S}_n . An easy computation gives

$$\langle \sigma|\tau \rangle = q^{\ell(\tau^{-1}\sigma)}$$

which is the matrix of $U_n(q)$ in the regular representation.

Hence, one has to prove that all operators $U_n(q)$ are positive definite for $-1 < q < 1$. By continuity, since $U_n(0)$ is the identity, it is sufficient to show that $U_n(q)$ is non singular in this range. This reduces the realizability problem to the invertibility of the q -shuffle operator for $-1 < q < 1$. This will follow from the computations of the forthcoming section, as well as the complete determination of the values for which $U_n(q)$ is invertible.

Define

$$T_n(q) = 12 \dots n-1 \odot n = \sum_{i=0}^{n-1} q^{n-1-i} (1 \dots i \ n \ i+1 \dots n-1) \quad (20)$$

(by Lemma 4.4). Embedding \mathfrak{S}_{n-1} in \mathfrak{S}_n , one can write

$$U_n(q) = (1 \odot_q \dots \odot_q n-1) \odot_q n = U_{n-1}(q)T_n(q)$$

so that $U_n(q) = T_2(q)T_3(q) \dots T_n(q)$. Taking reduced decompositions of the factors, we obtain:

Proposition 4.6 *For $n \geq 2$, one has the factorization*

$$U_n(q) = (1 \odot_q 2) (12 \odot_q 3) \dots (12 \dots n-1 \odot_q n) \quad (21)$$

$$\begin{aligned} &= (1 + q \sigma_1) (1 + q \sigma_2 + q^2 \sigma_2 \sigma_1) \dots \\ &\quad (1 + q \sigma_{n-1} + q^2 \sigma_{n-1} \sigma_{n-2} + \dots + q^{n-1} \sigma_{n-1} \dots \sigma_1) . \end{aligned} \quad (22)$$

□

Thus, $U_n(q)$ will be invertible if and only if all the $T_i(q)$ are invertible for $i \leq n$. These elements can themselves be factorized. To this purpose, we need to introduce two elements $G_n(q)$ and $D_n(q)$ of $\mathbb{Z}(q)[\mathfrak{S}_n]$, which are defined by induction. One first sets

$$G_1(q) = D_1(q) = 1 .$$

Let now $n \geq 2$ and suppose that $G_{n-1}(q)$ and $D_{n-1}(q)$ are defined. Denote by $g_{n-1}(q)$ and $d_{n-1}(q)$ the images of these elements in $\mathbb{Z}(q)[\mathfrak{S}_n]$ where we identify \mathfrak{S}_{n-1} with the stabilizer of 1 in \mathfrak{S}_n . That is,

$$g_{n-1}(q) = \eta_{n-1}^n(G_{n-1}(q)) \quad \text{and} \quad d_{n-1}(q) = \eta_{n-1}^n(D_{n-1}(q))$$

where η_{n-1}^n is the group morphism of \mathfrak{S}_{n-1} into \mathfrak{S}_n defined by

$$\eta_{n-1}^n(\sigma) = (1 \ \sigma(1)+1 \ \dots \ \sigma(n-1)+1)$$

for $\sigma \in \mathfrak{S}_{n-1}$. Then one defines

$$\begin{cases} G_n(q) &= (1 - q^n \gamma_n) g_{n-1}(q) \\ D_n(q) &= d_{n-1}(q) (1 - q^{n-1} \delta_n)^{-1} \end{cases} ,$$

where

$$\gamma_n = (n-1 \ 1 \ 2 \ \dots \ n-2 \ n) \quad \text{and} \quad \delta_n = (n \ 1 \ 2 \ \dots \ n-1) .$$

The complete factorization of $T_n(q)$ is then given by

Proposition 4.7 [40] *For all $n \geq 1$,*

$$T_n(q) = G_n(q) D_n(q) . \quad (23)$$

Then,

$$\begin{aligned} G_n(q) D_n(q) &= (1 - q^n \gamma_n) g_{n-1}(q) d_{n-1}(q) (1 - q^{n-1} \delta_n)^{-1} \\ &= (1 - q^n \gamma_n) t_{n-1}(q) (1 - q^{n-1} \delta_n)^{-1} \end{aligned}$$

where $t_{n-1}(q) = \eta_{n-1}^n(T_{n-1}(q))$. It suffices therefore to check that

$$T_n(q) (1 - q^{n-1} \delta_n) = (1 - q^n \gamma_n) t_{n-1}(q)$$

which follows from a straightforward computation. \square

Example 4.8 For $n \leq 4$, this gives

$$\begin{aligned} T_2(q) &= (1 - q^2) (1 - q(21))^{-1}, \\ T_3(q) &= (1 - q^3(213)) (1 - q^2) (1 - q(132))^{-1} (1 - q^2(312))^{-1}, \\ T_4(q) &= (1 - q^4(3124)) (1 - q^3(1324)) (1 - q^2) \\ &\quad (1 - q(1243))^{-1} (1 - q^2(1423))^{-1} (1 - q^3(4123))^{-1}. \end{aligned}$$

It is now easy to obtain an explicit formula for $T_n(q)^{-1}$ (which is a factorization of this element into $2n - 3$ terms). To state it, we need to introduce the elements $G'_n(q)$ and $D'_n(q)$ defined by $G'_1(q) = D'_1(q) = 1$ and by the recursive formulas

$$\begin{cases} G'_n(q) = (1 - q^{n-1} \gamma_n) g'_{n-1}(q) \\ D'_n(q) = d'_{n-1}(q) (1 + q^n \delta_n + q^{2n} (\delta_n)^2 + \dots + q^{(n-2)n} (\delta_n)^{n-2}) \end{cases},$$

where $g'_{n-1}(q) = \eta_{n-1}^n(G'_{n-1})$ and $d'_{n-1}(q) = \eta_{n-1}^n(D'_{n-1})$.

Proposition 4.9 [40] *If q is an indeterminate, $T_n(q)$ is invertible, and its inverse is*

$$T_n(q)^{-1} = \frac{1}{(1 - q^2) (1 - q^6) \dots (1 - q^{n(n-1)})} D'_n(q) G'_n(q). \quad (24)$$

Proof — It suffices to find the inverses of the linear factors, which are given by

$$(1 - q^n \delta_n)^{-1} = \frac{1}{1 - q^{n(n-1)}} (1 + q^n \delta_n + q^{2n} (\delta_n)^2 + \dots + q^{(n-2)n} (\delta_n)^{n-2}).$$

\square

Example 4.10 For $n = 2, 3, 4$, one has

$$\begin{aligned} T_2(q)^{-1} &= \frac{1}{1 - q^2} (1 - q(21)), \\ T_3(q)^{-1} &= \frac{1}{(1 - q^2)(1 - q^6)} (1 - q^2(312)) (1 - q(132)) (1 + q^3(213)), \\ T_4(q)^{-1} &= \frac{1}{(1 - q^2)(1 - q^6)(1 - q^{12})} (1 - q^3(4123)) (1 - q^2(1423)) \\ &\quad (1 - q(1243)) (1 + q^3(1324)) (1 + q^4(3124) + q^8(2314)). \end{aligned}$$

Corollary 4.11 [40] *For every $n \geq 1$, the operators $U_n(q)$ and $T_n(q)$ are invertible iff q is not a $k(k-1)$ -root of unity with some $k \in [1, n]$.*

Corollary 4.12 [40] *The operator $U(q)$ is invertible iff q is not a root of unity.*

We have also the following result of Zagier, which is also a special case of a general formula due to Varchenko (cf. [38], Theorem 1.1 or Section 6.4).

Corollary 4.13 [40, 38] *The determinant of $U_n(q)$ considered as an operator for the regular representation of \mathfrak{S}_n is*

$$\det U_n(q) = \prod_{k=2}^n (1 - q^{k(k-1)})^{(n-k+1)n!/(k(k-1))} .$$

Proof — Using the factorization of $T_n(q)$ and the fact that $\det(1 - q\gamma) = (1 - q^l)^{n!/l}$ if γ is a cycle of order l in \mathfrak{S}_n , we obtain

$$\det T_i(q) = \prod_{k=2}^i (1 - q^{k(k-1)})^{n!/(k(k-1))} .$$

□

4.5 A representation theoretical interpretation of the q -shuffle

The 0-Hecke algebra $H_n(0)$ is the \mathbb{C} -algebra obtained by specialization of the generic Hecke algebra $H_n(q)$ at $q = 0$. It is generated by elements T_1, T_2, \dots, T_{n-1} and has the following presentation :

$$\begin{aligned} T_i^2 &= -T_i && \text{for } i \in [1, n-1] , \\ T_i T_j &= T_j T_i && \text{for } |i - j| > 1 , \\ T_i T_{i+1} T_i &= T_{i+1} T_i T_{i+1} && \text{for } i \in [1, n-2] . \end{aligned}$$

For generic values of q , the Hecke algebra is semi-simple, and isomorphic to $\mathbb{C}\mathfrak{S}_n$. This is not the case when $q = 0$. In particular, the families of irreducible and indecomposable $H_n(0)$ -modules are not equal.

The irreducible $H_n(0)$ -modules are 1-dimensional, and parametrized by subsets of $1, \dots, n-1$ [27]. To see this, it is sufficient to observe that $(T_i T_{i+1} - T_{i+1} T_i)^2 = 0$. Thus, all the commutators $[T_i, T_j]$ are in the radical. But the quotient of $H_n(0)$ by the ideal generated by these elements is the commutative algebra generated by $n-1$ elements t_1, \dots, t_{n-1} subject to $t_i^2 = -t_i$. It is easy to check that this algebra has no nilpotent elements, so that it is $H_n(0)/(\text{rad } H_n(0))$. The irreducible representations are thus obtained by sending a set of generators to (-1) and its complement to 0. For reasons which will become transparent later, it is better to label these representations by compositions rather than by subsets. Let $I = (i_1, \dots, i_r)$ be a composition of n and let $D(I)$ the associated subset of $[1, n-1]$. The irreducible (1-dimensional) representation φ_I of $H_n(0)$ is defined by

$$\varphi_I(T_i) = \begin{cases} -1 & \text{if } i \in D(I) , \\ 0 & \text{if } i \notin D(I) , \end{cases}$$

finite dimensional $H_n(0)$ -module and consider a composition series of M , *i.e.* a decreasing sequence

$$M_1 = M \supset M_2 \supset \dots \supset M_k \supset M_{k+1} = \{0\}$$

of $H_n(0)$ -modules where every M_i/M_{i+1} is irreducible. There exists therefore for each $i \in [1, k]$ a composition I_i of n such that $M_i/M_{i+1} \simeq \mathbf{C}_{I_i}$. The Jordan-Hölder theorem ensures that the quasi-symmetric function

$$\mathcal{F}(M) = \sum_{i=1}^k F_{I_i}$$

is independent of the choice of the composition series. The quasi-symmetric function associated with M is called the *characteristic* of M . One can show that it has several properties in common with the usual Frobenius characteristic of a \mathfrak{S}_n -module [7]. In particular, the characteristic of an induced module

$$M = \mathbf{C}_{I_1} \otimes \mathbf{C}_{I_2} \otimes \dots \otimes \mathbf{C}_{I_r} \uparrow_{H_{n_1} \otimes H_{n_2} \otimes \dots \otimes H_{n_r}}^{H_{n_1+\dots+n_r}}$$

is the product of the characteristics of the factors [7]

$$\mathcal{F}(M) = F_{I_1} F_{I_2} \dots F_{I_r} . \quad (25)$$

These induced modules are cyclic, with generator the basis vector $e = 1 \otimes 1 \otimes \dots \otimes 1$ of the one-dimensional space $\mathbf{C}_{I_1} \otimes \mathbf{C}_{I_2} \otimes \dots \otimes \mathbf{C}_{I_r}$. The length filtration

$$H_n(0)^{(k)} = \bigoplus_{\ell(w) \geq k} \mathbf{C}T_w \quad (26)$$

of the 0-Hecke algebra induces a filtration of M

$$M^{(k)} = H_n(0)^{(k)} e \quad (27)$$

and this suggest the definition of a graded characteristic (for these particular modules) by

$$\mathcal{F}_q(M) = \sum_{k \geq 0} q^k \mathcal{F}(M^{(k)}/M^{(k+1)}) \quad (28)$$

Example 4.14 Take $I = (2)$, $J = (1, 1)$ and let $M_{((2),(1,1))}$ be the $H_4(0)$ -module obtained by inducing the $H_2(0) \otimes H_2(0)$ -module $\mathbf{C}_{(2)} \otimes \mathbf{C}_{(1,1)}$, identifying $H_2(0) \otimes H_2(0)$ to the subalgebra of $H_4(0)$ generated by T_1 and T_3 . Let $e = 1 \otimes 1$ be its standard generator, so that $T_1 e = 0$, $T_3 e = -e$, and $T_2 e$ is independent of e . The following automaton gives a complete description of the induced module. Its states, which correspond to images of e under the action of some basis element T_w of $H_4(0)$, form a basis of $M_{((2),(1,1))}$. An arrow indexed by T_i going from the state f to g means that $T_i \cdot f = g$, and a loop issued from a state f and labelled by $T_i|\epsilon$ (with $\epsilon = 0$ or $\epsilon = -1$) means that $T_i \cdot f = \epsilon f$.

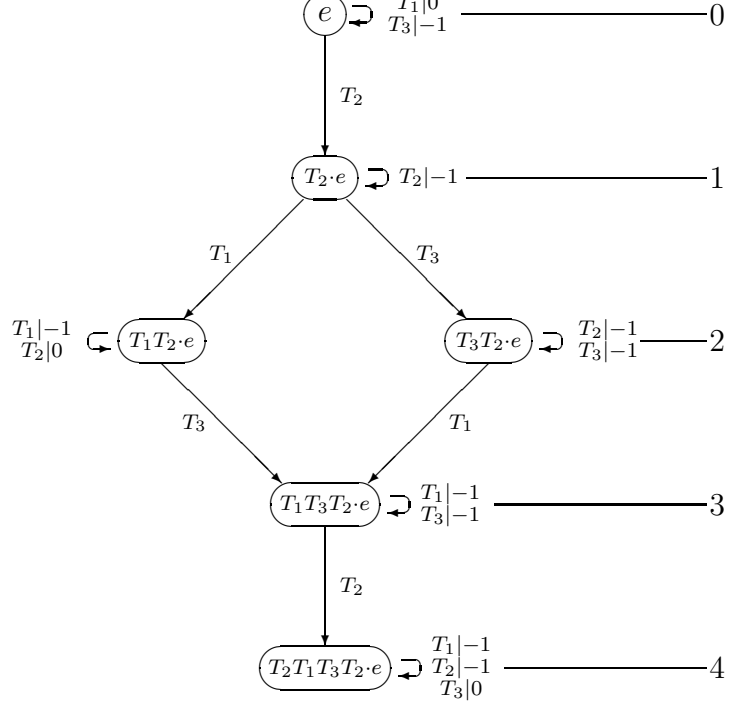

This automaton is naturally graded by the distance $d(f)$ of a state f to the initial state e as indicated on the picture, and it is clear that this grading corresponds precisely to the filtration used in the definition of \mathcal{F}_q . To be more explicit, if one associates with each state f of the automaton the composition $I(f)$ of 4 whose associated subset is

$$D(f) = \{ i \in [1, 3] \mid T_i \cdot f = -f \} ,$$

one has

$$\mathcal{F}_q(M_{((2),(1,1))}) = \sum_f q^{d(f)} F_{I(f)} .$$

The graded characteristic of $M_{((2),(1,1))}$ is equal to

$$\mathcal{F}_q(M_{((2),(1,1))}) = F_{31} + q F_{22} + q^2 (F_{13} + F_{211}) + q^3 F_{121} + q^4 F_{112} .$$

For $q = 1$, this characteristic is the product $F_2 F_{11}$, which can be obtained from the shuffle of 12 and 43 [30]. On the other hand, the q -shuffle of 12 and 43 is

$$12 \odot_q 43 = 1243 + q1423 + q^2 1432 + q^3 4123 + q^4 4132 + q^4 4312$$

and taking the descent compositions of the permutations in the right hand side, one recovers the graded characteristic of $M_{((2),(1,1))}$.

This example illustrates a general fact. The following proposition shows that the graded characteristic of an induced module as above is always given by the q -shuffle. As it is an associative operation, one obtains in this way a q -deformation of the ring of quasi-symmetric functions.

We denote here by $C(\sigma)$ the composition of n associated with the descent set of a permutation σ of \mathfrak{S}_n .

two permutations of $\mathfrak{S}_{[1,m]}$ and $\mathfrak{S}_{[m+1,m+n]}$ such that $C(\sigma) = I$ and $C(\tau) = J$. Then, the graded characteristic of the $H_{n+m}(0)$ -module obtained by inducing the $H_n(0) \otimes H_m(0)$ -module $\mathbf{C}_I \otimes \mathbf{C}_J$ (identifying $H_n(0) \otimes H_m(0)$ to the subalgebra of $H_{n+m}(0)$ generated by $T_1, \dots, T_{n-1}, T_{n+1}, \dots, T_{n+m-1}$) is given by

$$\mathcal{F}_q(\mathbf{C}_I \otimes \mathbf{C}_J \uparrow_{H_n(0) \otimes H_m(0)}^{H_{n+m}(0)}) = \sum_{\nu \in \mathfrak{S}_{n+m}} q^{d(\nu)} F_{C(\nu)}$$

where one has

$$\sigma \odot_q \tau = \sum_{\nu \in \mathfrak{S}_{n+m}} q^{d(\nu)} \nu .$$

Proof — Let $M_{I,J}$ be the induced $H_{n+m}(0)$ -module considered in the proposition. This module is generated by a $e = 1 \otimes 1$ on which $T_1, \dots, T_{n-1}, T_{n+1}, \dots, T_{n+m-1}$ act by

$$T_i \cdot e = \begin{cases} -1 & \text{if } i \in D(I) \text{ or } i \in n + D(J) , \\ 0 & \text{if } i \notin D(I) \text{ or } i \notin n + D(J) . \end{cases}$$

A basis of $M_{I,J}$ is given by elements of the standard basis T_σ of $H_n(0)$ indexed by permutations $\sigma \in \mathfrak{S}_n$ whose descent set $D(\sigma)$ is contained in $\{n\}$, *i.e.*

$$\mathcal{B}_n = \{ T_\sigma \cdot e \mid \sigma \in \mathfrak{S}_{n+m} \text{ and } D(\sigma) \subseteq \{n\} \} .$$

Let $R_{n,m}$ be the permutation

$$R_{n,m} = m+1 \ m+2 \ \dots \ m+n \ 1 \ 2 \ \dots \ m$$

of \mathfrak{S}_{n+m} . The following lemma gives a simple characterization of the permutations indexing the elements of the basis \mathcal{B}_n .

Lemma 4.16 *The set $\mathcal{D}_n = \{ \sigma \in \mathfrak{S}_{n+m} \mid D(\sigma) \subseteq \{n\} \}$ is equal to the interval $[id, R_{n,m}]$ in the permutohedron of \mathfrak{S}_{n+m} . \square*

We are now in position to prove proposition 4.15. We first suppose that $I = (n)$ and $J = (m)$. In this case, $T_i \cdot e = 0$ when $i \neq n$. It follows that the action of the generators of $H_n(0)$ on the basis \mathcal{B}_n of $M_{((n),(m))}$ is

$$T_i \cdot (T_\sigma \cdot e) = \begin{cases} 0 & \text{if } D(\sigma_i \sigma) \not\subseteq \{n\} , \\ -T_\sigma \cdot e & \text{if } i \in D(\sigma^{-1}) \\ T_{\sigma_i \sigma} \cdot e & \text{if } i \notin D(\sigma^{-1}) \text{ and } D(\sigma_i \sigma) = \{n\} , \end{cases}$$

for $i \in [1, n+m-1]$ and $\sigma \in \mathcal{D}_n$. Let $\mathcal{J}_{n,m}$ be the linear subspace of $\mathbb{C}[\mathfrak{S}_{n+m}]$ spanned by all permutations σ such that $D(\sigma) \not\subseteq \{n\}$, and consider the left action of $H_{n+m}(0)$ on $\mathbb{C}[\mathfrak{S}_{n+m}]/\mathcal{J}_{n,m}$ defined by

$$T_i \cdot \sigma = \begin{cases} -\sigma & \text{if } \sigma(i) < \sigma(i+1) , \\ \sigma \sigma_i & \text{if } \sigma(i) > \sigma(i+1) \end{cases} \quad (29)$$

and let $\varphi_{n,m}$ be the map from $M_{((n),(m))}$ into $\mathbb{C}[\mathfrak{S}_{n+m}]/\mathcal{J}_{n,m}$ sending $T_\sigma \cdot e$ to the permutation σ^{-1} . Thus, $\varphi_{n,m}$ is an isomorphism between $M_{((n),(m))}$ and the $H_{n+m}(0)$ -module generated by the identity permutation for the action (29). On the other hand,

$$\sum_{\sigma \in \mathcal{D}_n} \sigma^{-1} = (1 \ 2 \ \dots \ n) \sqcup (n+1 \ n+2 \ \dots \ n+m) .$$

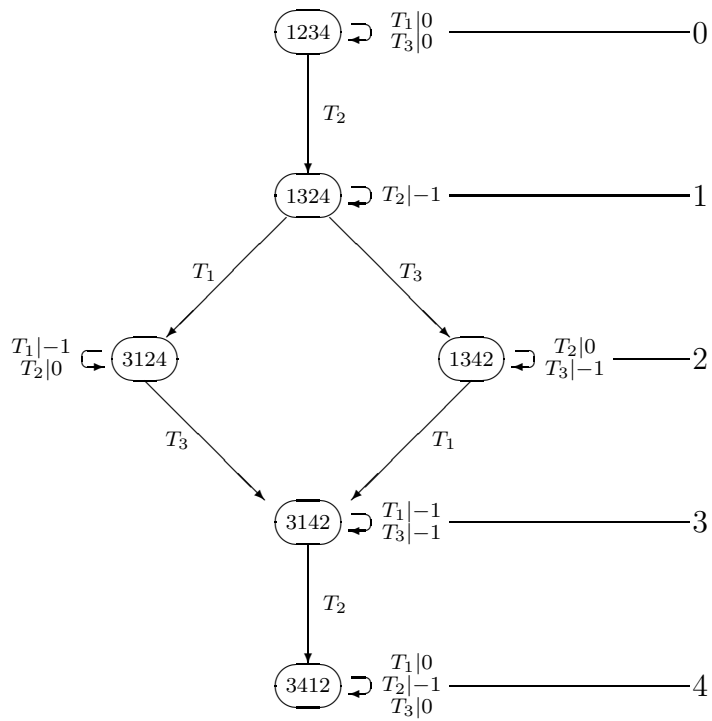

As in Example 4.14, the graded characteristic of $M_{((n),(m))}$ can be read on the permutations indexing the states of the automaton, which are given by the formula

$$\mathcal{F}_q(M_{((n),(m))}) = \mathcal{F}_q(\varphi_{n,m}(M_{((n),(m))})) = \sum_{\sigma \in \mathcal{D}_n} q^{\ell(\sigma)} F_{C(\sigma^{-1})}.$$

To get the proposition, it suffices therefore to prove that

$$(1 \ 2 \ \dots \ n) \odot_q (n+1 \ n+2 \ \dots \ n+m) = \sum_{\sigma \in \mathcal{D}_n} q^{\ell(\sigma)} \sigma^{-1}$$

or equivalently that

$$(1 \ 2 \ \dots \ n) \odot_q (n+1 \ n+2 \ \dots \ n+m) = \sum_{\sigma \in (1 \ 2 \ \dots \ m) \mathfrak{W}(n+1 \ n+2 \ \dots \ n+m)} q^{\ell(\sigma)} \sigma$$

which is clearly true. This proves therefore the proposition in special case $I = (n)$ and $J = (m)$. The general case follows from a similar argument. \square

Using the formula expressing the product of two quasi-ribbon functions in terms of shuffle product [14, 30] and taking $q = 1$, we recover (25).

This section is devoted to the study of the q -shuffle algebra as a Hopf algebra. We describe the primitive elements, and discuss the degeneration of the convolution algebra for $q \rightarrow 1$.

5.1 The q -shuffle Hopf algebra

Let A be an alphabet and let $(K\langle A \rangle, \odot_q)$ be the corresponding q -shuffle algebra. As shown in Section 3, one can associate with it the coproduct c_q defined by the following properties :

- $\forall a \in A, c_q(a) = 1 \otimes a + a \otimes 1,$
- $\forall P, Q \in K\langle A \rangle, c_q(P \odot_q Q) = c_q(P) \odot_q c_q(Q).$

Recall (from the proof of Proposition 3.1) that

$$c_q = (U(q) \otimes U(q)) \circ c \circ U(q)^{-1} \quad (30)$$

where $c = c_0$ is the usual coproduct of $K\langle A \rangle$. That is,

$$c_q(12 \dots n) = c(U_n(q)^{-1}) \cdot (U_n(q) \otimes U_n(q)) ,$$

and it suffices to apply the substitution $i \rightarrow a_i$ to this formula to get $c_q(a_1 a_2 \dots a_n)$.

Let ω be the involution sending a word w to $(-1)^{|w|} \tilde{w}$ and let ϵ be the constant term homomorphism.

Proposition 5.1 $(K\langle A \rangle, \odot_q, c_q)$ is a Hopf algebra with antipode ω and counit ϵ .

Proof — It suffices to check that ω is the antipode, with ϵ as counit. Note first that $U(q)$ and ω commute since

$$U_n(q) \circ \omega_n = \omega_n \circ U_n(q)$$

(where ω_n denotes the maximal permutation of \mathfrak{S}_n). The property follows then from (30), since ω is also the antipode for the usual coproduct c . \square

The combinatorial structure of the coproduct c_q is however not clear at all. We have tabulated $c_q(12 \dots n)$ up to $n = 6$ and no simple formula seems to emerge. We list below the results for $n \leq 3$.

Example 5.2 For $n = 2$ and $n = 3$, one has

$$\begin{aligned} c_q(12) &= 12 \otimes \emptyset + \frac{1}{1+q} (1 \otimes 2 + 2 \otimes 1) + \emptyset \otimes 12 , \\ c_q(123) &= 123 \otimes \emptyset - \frac{q^2}{(1+q)(1+q+q^2+q^3+q^4+q^5)} (1 \otimes 32 + 32 \otimes 1 + 3 \otimes 21 + 21 \otimes 3) \\ &\quad + \frac{1+q^4}{(1+q)(1+q+q^2+q^3+q^4+q^5)} (2 \otimes 13 + 13 \otimes 2) \\ &\quad + \frac{q+q^3}{(1+q)(1+q+q^2+q^3+q^4+q^5)} (2 \otimes 31 + 31 \otimes 2) \\ &\quad + \frac{1+q+q^2+q^3+q^4}{(1+q)(1+q+q^2+q^3+q^4+q^5)} (1 \otimes 23 + 23 \otimes 1 + 12 \otimes 3 + 3 \otimes 12) + \emptyset \otimes 123 . \end{aligned}$$

in particular that the convolution algebra associated with the q -shuffle algebra degenerates into a commutative algebra when $q \rightarrow 1$ (see Section 5.3 below).

Conjecture 5.1 *There exists a family $(f_{\sigma,\tau}(q))$ of rational functions in $\mathbb{Z}(q)$ which do not have 1 as zero nor as pole, such that for all $n \geq 1$,*

$$c_q(12 \dots n) = \sum_{\substack{\sigma, \tau \\ 12 \dots n \in \sigma \mathbf{u} \tau}} f_{\sigma, \tau}(q) \sigma \otimes \tau .$$

Note 5.3 The dual Hopf algebra of the q -shuffle algebra is the algebra $(K\langle A \rangle, \square_q, \Delta_q)$ with product \square_q and coproduct Δ_q defined by

$$(u \square_q v | w) = (u \otimes v | c_q(w)) \quad \text{and} \quad (\Delta(w) | u \otimes v) = (w | u \odot_q v)$$

for $u, v, w \in A^*$. The product \square_q dual to the coproduct c_q is not easily described. On the other hand, one can completely describe the coproduct Δ_q by the following formula

$$\Delta_q(12 \dots n) = \sum_{12 \dots n \in \sigma \mathbf{u} \tau} q^{l(\sigma \cdot \tau)} \sigma \otimes \tau$$

where $\sigma \cdot \tau$ denotes here the permutation obtained by concatenating σ and τ considered as words.

5.2 Primitive elements for c_q

We shall now have a look at the set $Prim_q$ of primitive elements for c_q . These elements occur in several decompositions of the free associative algebra and in the description of the associated convolution algebra. According to the general theory, $Prim_q$ is just the image under $U(q)$ of the set of primitive elements for the shuffle coproduct c , *i.e.* of the free Lie algebra $L(A)$. That is,

$$Prim_q = U(q)(L(A)) = \bigoplus_{n \geq 1} L_n(A) \cdot U_n(q) .$$

This shows that a basis of the standard component of $Prim_q$ is for instance given by $(\sigma \circ \theta_n \circ U_n(q))_{\sigma \in \mathfrak{S}_n, n \geq 1}$ where θ_n is the Dynkin idempotent of order n . Hence any explicit formula for $\theta_n \circ U_n(q)$ gives us an explicit description of $Prim_q$.

In order to obtain a description of $\theta_n \circ U_n(q)$, let us introduce the left t -bracketing operator $\Theta_n(t)$ which is the element of $\mathbb{Z}[t][\mathfrak{S}_n]$ defined by

$$\Theta_n(t) = [[\dots [[[1, 2]_t, 3]_t, \dots]_t, n]_t$$

where $[P, Q]_t = PQ - tQP$.

Proposition 5.4

$$\Theta_n(t) \circ U_n(q) = \sum_{\sigma \in \mathfrak{S}_n} P_\sigma(t, q) \sigma , \tag{31}$$

where $P_\sigma(t, q)$ is the polynomial of $\mathbb{Z}[t, q]$ recursively defined by

$$P_1 = 1 \quad \text{and} \quad P_\sigma(t, q) = \begin{cases} q^{i-1} (q^{n-2i+1} - t) P_\tau(t, q) & \text{if } 1 \leq i \leq \lfloor \frac{n+1}{2} \rfloor , \\ q^{n-i} (1 - t q^{2i-n-1}) P_\tau(t, q) & \text{if } \lfloor \frac{n+1}{2} \rfloor \leq i \leq n , \end{cases} \tag{32}$$

where $i = \sigma^{-1}(n)$ and where τ is the permutation of \mathfrak{S}_{n-1} obtained from σ by deleting n .

of $\Theta_n(t)$ given by

$$\Theta_n(t) = (1 - t g_2) (1 - t g_3) \dots (1 - t g_n) ,$$

where g_i denotes here the cycle $(i \ 1 \dots i - 1)$ of \mathfrak{S}_i . □

Example 5.5 Let $\sigma = 23541 \in \mathfrak{S}_5$. Then,

$$\begin{aligned} P_{23541}(t, q) &= q^2 (1 - t) P_{2341}(t, q) \\ &= (q^2 (1 - t)) q (1 - t q) P_{231}(t, q) \\ &= (q^3 (1 - t) (1 - t q)) q (1 - t) P_{21}(t, q) \\ &= (q^4 (1 - t)^2 (1 - t q)) (q - t) P_1(t, q) \\ &= q^4 (q - t) (1 - t)^2 (1 - t q) . \end{aligned}$$

Specializing $t = 1$ in the proposition leads to an explicit formula for $\theta_n \circ U_n(q)$. To state precisely this result, we need to introduce the elements $\tau_n(q)$ of $\mathbb{Z}(q)[\mathfrak{S}_n]$ defined according to the parity of n by

$$\left\{ \begin{array}{l} \tau_{2n}(q) = \sum_{i=1}^n q^{i-1} \frac{[2n - 2i + 1]_q}{[2n - 1]_q} (12 \dots 2n - i \ 2n \ 2n - i + 1 \dots 2n - 1) \\ \quad - \sum_{i=1}^n q^{n-i} \frac{[2i - 1]_q}{[2n - 1]_q} (12 \dots n - i \ 2n \ n - i + 1 \dots 2n - 1) , \\ \tau_{2n+1}(q) = \sum_{i=1}^n q^{i-1} \frac{[2n - 2i + 2]_q}{[2n]_q} (12 \dots 2n - i + 1 \ 2n + 1 \ 2n - i + 2 \dots 2n) \\ \quad - \sum_{i=1}^n q^{n-i} \frac{[2i]_q}{[2n]_q} (12 \dots n - i \ 2n + 1 \ n - i + 1 \dots 2n) . \end{array} \right.$$

As a consequence of Proposition 5.4, we can give a factorization formula for $\theta_n \circ U_n(q)$.

Corollary 5.6 For all $n \geq 2$,

$$\theta_n \circ U_n(q) = (1 - q) (1 - q^2) \dots (1 - q^{n-1}) \tau_2(q) \tau_3(q) \dots \tau_n(q) . \quad (33)$$

Example 5.7 For $n = 4, 5$, we have

$$\begin{aligned} \theta_4 \circ U_4(q) &= (1 - q)(1 - q^2)(1 - q^3) (1234 - 2134) (1234 - 3124) \\ &\quad (1234 + \frac{q}{1 + q + q^2} 1243 - \frac{q}{1 + q + q^2} 1423 - 4123) , \\ \theta_5 \circ U_5(q) &= (1 - q)(1 - q^2)(1 - q^3)(1 - q^4) (12345 - 21345) (12345 - 31245) \\ &\quad (12345 + \frac{q}{1 + q + q^2} 12435 - \frac{q}{1 + q + q^2} 14235 - 41235) \\ &\quad (12345 + \frac{q}{1 + q^2} 12354 - \frac{q}{1 + q^2} 15234 - 51234) . \end{aligned}$$

Let us now introduce the element $\lambda_n(q)$ of $\mathbb{Z}(q)[\mathfrak{S}_n]$ defined by

$$\lambda_n(q) = [(n - 1)]_q! \tau_2(q) \tau_3(q) \dots \tau_n(q) ,$$

so that

$$\theta_n \circ U_n(q) = (1 - q)^{n-1} \lambda_n(q) . \quad (34)$$

The image of the operator $w \rightarrow w \cdot \lambda_n(q)$ (where w runs through words of length n) is exactly the set of homogeneous primitive elements of order n for c_q . In other words, one has the following description:

$$Prim_q = \bigoplus_{n \geq 1} K(q) \langle A \rangle_n \cdot \lambda_n(q) .$$

According to the general theory, the convolution algebra $\Sigma_n(q)$ associated with the q -shuffle Hopf algebra is equal to

$$\Sigma_n(q) = \bigoplus_{|I|=n} K U_n(q)^{-1} \circ D_I \circ U_n(q)$$

where D_I is the sum of all permutations with descent set $D(I)$. Unfortunately, due to the intricate structure of $U_n(q)$, it does not seem possible to give a simple description of $\Sigma_n(q)$ for $n \geq 4$ (for $n = 2$ and $n = 3$, one can check that $\Sigma_n(q)$ is in fact equal to the usual descent algebra Σ_n).

The following conjecture, basically due to Zagier [40], would give some indications on the structure of $U_n(q)^{-1}$.

Conjecture 5.2 *Let ω_n denote the maximal permutation of \mathfrak{S}_n . For all $n \geq 1$, the inverse of $U_n(q)$ has the form*

$$U_n(q)^{-1} = \frac{1}{(1-q^2) \dots (1-q^{n(n-1)})} \left(\sum_{\sigma \in \mathcal{D}_n} (-1)^{|D(\sigma)|} p_\sigma(q) \sigma \right) (1 + (-1)^{n-1} q^{n(n-1)/2} \omega_n),$$

where $p_\sigma(q)$ is a polynomial in $\mathbb{N}[q]$ and where \mathcal{D}_n is a subset of \mathfrak{S}_n whose cardinality is equal to the number of planar trees with n leaves.

Zagier's conjecture would give a description of the limit of the convolution algebra $\Sigma_n(q)$ when $q \rightarrow 1$ whenever this degenerate limit exists¹. Indeed, a basis of $\Sigma_n(q)$ is given by

$$\alpha_q(\Psi^I) = (U_{i_1}(q)^{-1} \circ \theta_{i_1} \circ U_{i_1}(q)) \otimes_q \dots \otimes_q (U_{i_r}(q)^{-1} \circ \theta_{i_r} \circ U_{i_r}(q))$$

for $|I| = n$. The conjecture would imply, taking into account (34), that

$$\lim_{q \rightarrow 1} U_n(q)^{-1} \circ \theta_n \circ U_n(q) = \frac{1}{n!} \left(\sum_{\sigma \in \mathcal{D}_n} (-1)^{|D(\sigma)|} p_\sigma(1) \sigma \right) (1 + (-1)^{n-1} \omega_n) \lambda_n(1).$$

These elements would therefore generate the limit convolution algebra $\Sigma_n(1)$, if it exists.

The expression of $U_n(q)^{-1}$ given by Zagier's Conjecture can be interpreted as the decomposition on the family $(\sigma \lambda_n(1))$ of the idempotent corresponding to the projection on the homogeneous component of order n of

$$\mathcal{L} = \bigoplus_{n \geq 1} K \langle A \rangle_n \cdot \lambda_n(1)$$

with respect to the decomposition

$$K \langle A \rangle = K \oplus \mathcal{L} \oplus \mathcal{L} \sqcup \mathcal{L} \oplus \dots \oplus \underbrace{\mathcal{L} \sqcup \dots \sqcup \mathcal{L}}_{n \text{ times}} \oplus \dots$$

of the free associative algebra $K \langle A \rangle$.

¹ The existence of a limit convolution algebra $\Sigma_n(1)$ would be a consequence of Conjecture 5.1.

The aim of this section is to present interesting generalizations of the shuffle operator of which the q -shuffle product is the simplest case.

6.1 Rosso's quantum shuffles

Rosso showed, by expliciting their multiplication, that certain Hopf algebras obtained by very general constructions can be interpreted as generalizations of the shuffle algebra [31]. These algebras are constructed as follows.

Let H be a Hopf algebra over a field K . A *Hopf bimodule* M over H is a K -vector space endowed with compatible structures of H -bimodule and H -bicomodule [26]. In other words, a Hopf bimodule over H is a H -bimodule M equipped with left and right coactions $\delta_L : M \rightarrow H \otimes M$ and $\delta_R : M \rightarrow M \otimes H$ commuting with each other (i.e. such that $(id \otimes \delta_R) \delta_L = (\delta_L \otimes id) \delta_R$) and which are morphisms of H -bimodules.

The following proposition is a particular case of a result of Woronowicz.

Proposition 6.1 [39] *Let M be a Hopf H -bimodule. There exists a unique H -bimodule endomorphism σ_M of $M \otimes_H M$ such that*

$$\forall m, n \in M, \delta_L(m) = 1 \otimes m, \delta_R(n) = n \otimes 1 \implies \sigma_M(m \otimes n) = n \otimes m .$$

Moreover σ_M is invertible and satisfies to the braid equation

$$(Id_M \otimes \sigma_M) (\sigma_M \otimes Id_M) (Id_M \otimes \sigma_M) = (\sigma_M \otimes Id_M) (Id_M \otimes \sigma_M) (\sigma_M \otimes Id_M) .$$

Recall that the braid group \mathcal{B}_n is the (infinite) group generated by $n - 1$ elements $(s_i)_{i=1, n-1}$ subject to the relations

$$\begin{aligned} s_i s_j &= s_j s_i && \text{for } |i - j| > 1 , \\ s_i s_{i+1} s_i &= s_{i+1} s_i s_{i+1} && \text{for } i \in [1, n - 2] . \end{aligned}$$

For each permutation $\sigma \in \mathfrak{S}_n$, one can define an element T_σ of \mathcal{B}_n by $T_\sigma = s_{i_1} \dots s_{i_r}$ where $\sigma_{i_1} \dots \sigma_{i_r}$ is an arbitrary reduced decomposition of σ .

Let M be a Hopf H -bimodule and let $M^L = \{m \in M, \delta_L(m) = 1 \otimes m\}$ be the submodule of left coinvariants. The proposition allows to define a right action of the braid group \mathcal{B}_n on $(M^L)^{\otimes n}$ by

$$x_1 \otimes \dots \otimes x_n \cdot s_i = (Id_{M^L}^{\otimes(i-1)} \otimes \sigma_M \otimes Id_{M^L}^{\otimes(n-i-1)}) (x_1 \otimes \dots \otimes x_n) \quad (35)$$

for every $x_1, \dots, x_n \in M^L$.

On the other hand, it can be shown that $T(M^L)$ is isomorphic to the space of left coinvariants of the cotensor coalgebra $T_H^c(M)$, which is known by a result of Nichols [26] to be a Hopf algebra. This isomorphism endows therefore $T(M^L)$ with a new product \odot , and Rosso shows that it can be explicited as follows, in terms of the braid group action on $T(M^L)$.

Proposition 6.2

$$(x_1 \otimes \dots \otimes x_p) \odot (x_{p+1} \otimes \dots \otimes x_n) = \sum_{\sigma \in 12\dots p \mathbb{1} p+1 p+2 \dots n} (x_1 \otimes \dots \otimes x_n) \cdot T_\sigma$$

where \cdot denotes the right action of \mathcal{B}_n on $(M^L)^{\otimes n}$ defined by (35).

vector space, and $R \in \text{End}(V \otimes V)$ be a solution of the Yang-Baxter equation

$$R_{12}R_{13}R_{23} = R_{23}R_{13}R_{12} \quad (36)$$

where as usual $R_{i,j}$ is the endomorphism of $V \otimes V \otimes V$ acting as R on the i -th and j -th factors. Also, let $\check{R} = PR$, where $P(u \otimes v) = v \otimes u$, so that \check{R} satisfies the braid relation

$$\check{R}_{12}\check{R}_{23}\check{R}_{12} = \check{R}_{23}\check{R}_{12}\check{R}_{23} . \quad (37)$$

One defines then as usual a right action of \mathcal{B}_n on $V^{\otimes n}$ by

$$v_1 \otimes v_2 \otimes \cdots \otimes v_n \cdot s_i = \check{R}_{i,i+1}(v_1 \otimes v_2 \otimes \cdots \otimes v_n) . \quad (38)$$

The fundamental observation is the following

Lemma 6.3 *Define a multiplication \odot on $T(V)$ by*

$$(x_1 \otimes \cdots \otimes x_p) \odot (x_{p+1} \otimes \cdots \otimes x_n) = \sum_{\sigma \in 12\dots p \mathbf{u} p+1 p+2 \dots n} (x_1 \otimes \cdots \otimes x_n) \cdot T_\sigma$$

for $x_1, \dots, x_n \in V$. Then, \odot is associative.

Proof — Consider first the case where R is the identity of $V \otimes V$. Then \odot is the ordinary shuffle product, which is indeed associative. Let ρ be the representation of \mathcal{B}_∞ defined by R , and let

$$\text{sh}(p, q) = \sum_{\sigma \in 12\dots p \mathbf{u} p+1 \dots p+q} T_\sigma$$

The associativity of \odot is equivalent to the validity of the identities

$$\rho(\text{sh}(p, q)\text{sh}(p+q, r)) = \rho(\text{sh}(q, r)\text{sh}(p, q+r)) \quad (39)$$

in the given representation. But taking reduced decompositions of both sides and expanding the products, one obtains only reduced words. The identity being true for the symmetric group, it is valid in the algebra of the braid group, and therefore in any representation. \square

Example 6.4 1) The q -shuffle \odot_q is the particular case obtained by taking $R = q \cdot I$, where I is the identity of $V \otimes V$ (and V is $\bigoplus_{a \in A} K a$).

2) Let (e_i) be a basis of V . Diagonal matrices $R(e_i \otimes e_j) = q_{ij}e_i \otimes e_j$ satisfy the Yang-Baxter equation. If $A = (a_{ij})$ is a symmetrizable Cartan matrix and if (d_i) are relatively prime positive integers such that $(d_i a_{ij})$ is symmetric, Rosso shows that the triangular part of the quantized enveloping algebra associated to A is a subalgebra of the corresponding quantum shuffle algebra.

3) Take $V = K[x]$, where $K = \mathbb{C}(q)$, and identify $V^{\otimes n}$ with $K[x_1, x_2, \dots, x_n]$. The standard action of the Hecke algebra $H_n(q)$ on $K[x_1, \dots, x_n]$ by symmetrizing operators [5]

$$T_i = (q-1)\pi_i + \sigma_i \quad (40)$$

$$\pi_i(P) = \frac{x_i P - x_{i+1} \sigma_i(P)}{x_i - x_{i+1}}$$

gives a solution of the Yang-Baxter equation and induces as above an action of the braid group on $V^{\otimes n}$. The subspace of $V^{\otimes n}$ spanned by \odot products of elements of V can be identified with the space of symmetric polynomials in x_1, \dots, x_n , and the factorization formula for the total symmetrizer $S^{(n)} = \sum_{\sigma \in \mathfrak{S}_n} T_\sigma$ given in [5], Theorem 3.1, implies that for a partition $\lambda = (\lambda_1 \geq \lambda_2 \geq \dots \geq \lambda_n > 0)$, the product

$$x^{\lambda_1} \odot x^{\lambda_2} \odot \dots \odot x^{\lambda_n}$$

is equal, up to a scalar factor, to the Hall-Littlewood polynomial $Q_\lambda(x_1, \dots, x_n; 1/q)$.

4) Other families of symmetric functions can be obtained by considering degenerate actions, for example the Schur functions or the augmented monomial functions

5) The q -wedge product introduced by Stern [37] and Kashiwara-Miwa-Stern [18] can also be regarded as a special case of this construction, obtained from an action of the affine Hecke algebra commuting with $U_q(\widehat{sl}_n)$.

6.2 Twisted derivations and multi-parameter deformations of the shuffle product

This section explains how the consideration of twisted derivations allows one to recover in a natural way the multi-parameter deformations of the shuffle product associated to diagonal solutions of the Yang-Baxter equation.

Definition 6.5 *A twisted derivation for a K -algebra structure $(K\langle A \rangle, +, \odot)$ constructed over $K\langle A \rangle$ is a linear map ∂ from $K\langle A \rangle$ into $K\langle A \rangle$ which satisfies for words $u, v \in A^*$ to the Leibnitz rule*

$$\partial(u \odot v) = \partial(u) \odot v + \chi(u) u \odot \partial(v) ,$$

where χ is a monoid morphism from A^* into K .

Example 6.6 Let $(q_a)_{a \in A}$ (resp. $(\partial(a))_{a \in A}$) be an arbitrary family of elements of K (resp. of $K\langle A \rangle$). One can define a derivation ∂ on the free associative algebra $(K\langle A \rangle, +, \cdot)$ by

$$\partial(w) = \sum_{uav=w} q_u u \partial(a) v ,$$

where for $u = a_1 \cdots a_n \in A^*$, q_u denotes the element $q_{a_1} \cdots q_{a_n}$.

Consider now the classical twisted derivations $(\partial_a)_{a \in A}$ on $K\langle A \rangle$, defined for each letter $a \in A$ by

$$\partial_a(w) = \begin{cases} u & \text{if } w = a u \\ 0 & \text{if } w \notin aA^* \end{cases}$$

for $w \in A^*$. These operators are widely used in automata theory, *e.g.* for defining the algebra of rational series (*cf.* [2]). They are also twisted derivations for the q -shuffle algebra, since by definition

$$\partial_a(u \odot_q v) = \partial_a(u) \odot_q v + q^{|u|} u \odot_q \partial_a(v)$$

for $u, v \in A^*$. One can then ask whether there are other products for which all operators ∂_a are still twisted derivations. The following proposition answers this question in the case where the twisting morphism χ is given by means of a matrix of commutation factors.

$$q(u, v) = \prod_{i,j} q_{a_i, b_j}$$

for all words $u = a_1 \dots a_n$ and $v = b_1 \dots b_m$. There exists then a unique graded product \odot_M on $K\langle A \rangle$ such that

$$\begin{aligned} \forall u \in A^*, \quad u \odot_M 1 &= 1 \odot_M u = u, \\ \forall u, v \in A^*, \quad \partial_a(u \odot_M v) &= \partial_a(u) \odot_M v + q(a, u) u \odot_M \partial_a(v), \end{aligned}$$

for every $a \in A$. This product can be computed by the following recursive formulas

$$\begin{aligned} u \odot_M 1 &= 1 \odot_M u = u, \\ (au) \odot_M (bv) &= a(u \odot_M bv) + q(b, au) b(au \odot_M v), \end{aligned}$$

where $u, v \in A^*$ and $a, b \in A$.

Proof — A straightforward calculation, which is left to the reader. \square

The product \odot_M defined in the proposition is associative. One can therefore consider the algebra $(K\langle A \rangle, +, \odot_M)$. Observe that this algebra reduces to the q -shuffle algebra when all indeterminates $q_{a,b}$ are equal to q . In the general case, the product \odot_M is still a special case of the construction of Section 3. Indeed,

$$a_1 \odot_M a_2 \odot_M \dots \odot_M a_n = a_1 a_2 \dots a_n \cdot U_n(M)$$

for $a_i \in A$, and where

$$U_n(M) = \sum_{\sigma \in \mathfrak{S}_n} \left(\prod_{\substack{1 \leq i < j \leq n \\ \sigma(i) > \sigma(j)}} q_{a_{\sigma(i)}, a_{\sigma(j)}} \right) \sigma.$$

Thus, $(K\langle A \rangle, +, \odot_M)$ is shuffle Hopf algebra associated to the diagonal solution $R(x \otimes y) = q_{x,y}(x \otimes y)$ of the Yang-Baxter equation.

Note 6.8 If one forgets about the first condition in the proposition, there are other interesting solutions, such as the T -operation of Schützenberger [32], also called “chronological product” [19].

Note 6.9 When the matrix M is skew-symmetric in the multiplicative sense, *i.e.* when $q_{a,b} = q_{b,a}^{-1}$ for every $a, b \in A$, one recovers the bicharacters introduced by Ree in [28]. Let us recall that a bicharacter χ is a bilinear mapping from $\mathbb{N}^{(A)} \times \mathbb{N}^{(A)}$ into (K, \times) , *i.e.* a mapping such that

$$\chi(x, y + z) = \chi(x, y) \chi(x, z) \quad \text{and} \quad \chi(x + y, z) = \chi(x, z) \chi(y, z)$$

hold for every $x, y, z \in \mathbb{N}^{(A)}$. Let now $(\varepsilon_a)_{a \in A}$ be the basis of $\mathbb{N}^{(A)}$ defined by $\varepsilon_a(b) = \delta_{a,b}$ for $a, b \in A$. The mapping which associates to a skew-symmetric matrix $M = (q_{a,b})_{a,b \in A}$ the bicharacter $\chi(\varepsilon_a, \varepsilon_b) = q_{a,b}$ is then clearly a one-to-one correspondence between bicharacters and skew-symmetric $A \times A$ -matrices.

It is also interesting to observe that $End^{gr}(K\langle A \rangle)$ can be equipped in this case with a structure of Lie superalgebra defined by

$$[f, g] = fg - \chi(deg(f), deg(g)) gf.$$

The space of graded twisted derivations over $(K\langle A \rangle, +, \odot_M)$ becomes then a super Lie subalgebra of this superalgebra. Moreover it can be shown that the derivations $(\partial_a)_{a \in A}$ generates the free Lie superalgebra $L_\chi(A)$.

Rosso's construction suggests that the combinatorics of generalized shuffles has to be understood at the level of the braid group algebra. This point of view leads to a uniform presentation of several factorization results, and reveals a connection between quantum shuffles and Varchenko's construction of a quantum bilinear form associated to a hyperplane arrangement.

6.3.1 A shuffle element in the braid group algebra

Let \mathcal{B}_∞ denote the infinite braid group, generated by elements $(s_i)_{i \geq 1}$ satisfying to the relations $s_i s_j = s_j s_i$ for $|i - j| > 1$ and $s_i s_{i+1} s_i = s_{i+1} s_i s_{i+1}$. Since every braid group \mathcal{B}_n can be embedded in \mathcal{B}_∞ , the notation T_σ will be still used in this context.

One can define a shuffle element \mathcal{U}_n in $K[\mathcal{B}_\infty]$ by

$$\mathcal{U}_n = \sum_{\sigma \in \mathfrak{S}_n} T_\sigma .$$

The q -shuffle operator is the image of \mathcal{U}_n under the representation $s_i \rightarrow q \sigma_i$. Thus any factorization of \mathcal{U}_n will also hold in particular for the q -shuffle operator $U_n(q)$.

6.3.2 Factorizations

More generally any factorization of \mathcal{U}_n will provide similar decompositions in any homomorphic image of the braid group. We will first give a decomposition formula for \mathcal{U}_n which can be viewed as the generalization of Zagier's factorization of the q -shuffle operator.

Consider the element \mathcal{T}_n of the algebra of \mathcal{B}_∞ defined by

$$\mathcal{T}_n = 1 + s_{n-1} + s_{n-1} s_{n-2} + \dots + (s_{n-1} s_{n-2} \dots s_1) .$$

One can then give the following factorization of \mathcal{U}_n in $\mathbb{N}[\mathcal{B}_\infty]$.

Proposition 6.10 *For every $n \geq 2$, one has*

$$\mathcal{U}_n = \mathcal{T}_2 \mathcal{T}_3 \dots \mathcal{T}_n .$$

Proof — The formula is true in the representation $s_i \mapsto \sigma_i$, and expanding the product yields only reduced words. \square

The elements \mathcal{T}_n can themselves be factorized, and we obtain in this way a factorization of \mathcal{U}_n in $\mathbb{Z}[[\mathcal{B}_\infty]]$, which projects onto Zagier's factorization under $s_i \rightarrow q \sigma_i$.

Proposition 6.11 *For $n \geq 2$, one has in $\mathbb{Z}[[\mathcal{B}_\infty]]$:*

$$\begin{aligned} \mathcal{T}_n &= (1 - s_{n-1}^2 s_{n-2} \dots s_1) (1 - s_{n-1}^2 s_{n-2} \dots s_2) \dots (1 - s_{n-1}^2) \\ &\quad (1 - s_{n-1})^{-1} (1 - s_{n-1} s_{n-2})^{-1} \dots (1 - s_{n-1} s_{n-2} \dots s_1)^{-1} . \end{aligned}$$

Proof — The proposition follows from the following lemma, whose proof is left to the reader.

$$\mathcal{T}_n (1 - s_{n-1} s_{n-2} \dots s_1) = (1 - s_{n-1}^2 s_{n-2} \dots s_1) t_{n-1}$$

where t_{n-1} denotes the image of \mathcal{T}_{n-1} under the algebra morphism η of $\mathbb{N}[\mathcal{B}_\infty]$ defined by $\eta(s_i) = s_{i+1}$ for all $i \geq 1$.

Example 6.13 For $n = 2, 3, 4$,

$$\mathcal{T}_2 = (1 - s_1^2) (1 - s_1) ,$$

$$\mathcal{T}_3 = (1 - s_2^2 s_1) (1 - s_2^2) (1 - s_2)^{-1} (1 - s_2 s_1)^{-1} ,$$

$$\mathcal{T}_4 = (1 - s_3^2 s_2 s_1) (1 - s_3^2 s_2) (1 - s_3^2) (1 - s_3)^{-1} (1 - s_3 s_2)^{-1} (1 - s_3 s_2 s_1)^{-1} .$$

Specializing these results in a homomorphic image of the braid group, we get the following useful corollary:

Corollary 6.14 For any representation ρ of \mathcal{B}_n , one has

$$\rho(\mathcal{U}_n) = \rho(\mathcal{T}_2) \rho(\mathcal{T}_3) \dots \rho(\mathcal{T}_n) ,$$

and if the inverses are defined,

$$\rho(\mathcal{T}_n) = \prod_{1 \leq i \leq n-1}^{\rightarrow} (1 - \rho(s_{n-1}^2 s_{n-2} \dots s_i)) \prod_{1 \leq i \leq n-1}^{\leftarrow} (1 - \rho(s_{n-1} s_{n-2} \dots s_i))^{-1} .$$

Note 6.15 Typical examples where the inverses are well defined are the representations $s_i \rightarrow qs_i$ in $\mathbb{C}[\mathfrak{S}_n]$ or the Hecke algebra $H_n(t)$ where the factors of the elements $\rho(\mathcal{T}_i)$ satisfy polynomial equations with non-zero constant terms and hence are invertible. For example for the symmetric group, with $X = \rho(s_{n-1} s_{n-2} \dots s_i)$ (resp. $Y = \rho(s_{n-1}^2 s_{n-2} \dots s_i)$) one has

$$X^{n-i+1} = q^{(n-i+1)(n-i)}; \quad (1 - X) \left(\sum_{j=0}^{n-i} X^j \right) = 1 - q^{(n-i+1)(n-i)}$$

Hence

$$(1 - X)^{-1} = (1 - q^{(n-i+1)(n-i)})^{-1} \left(\sum_{j=0}^{n-i} X^j \right)$$

similarly

$$Y^{n-i-1} = q^{(n-i+1)(n-i)}; \quad (1 - Y) \left(\sum_{j=0}^{n-i-2} Y^j \right) = 1 - q^{(n-i+1)(n-i)}$$

and then

$$(1 - Y)^{-1} = (1 - q^{(n-i+1)(n-i)})^{-1} \left(\sum_{j=0}^{n-i-2} Y^j \right)$$

so that the denominator of Zagier's formula can be lowered to

$$\prod_{m=2}^n \prod_{i=1}^{m-1} (1 - q^{(m-i+1)(m-i)}) = \prod_{k=1}^{n-1} (1 - q^{k(k+1)})^{n-k}$$

Let $M = (q_{a,b})_{a,b \in A}$ be a matrix of indeterminates. The action of \mathcal{B}_n defined in Example 6.4 can be described as the right action \cdot of \mathcal{B}_n on words defined by

$$(a_1 a_2 \dots a_n) \cdot s_i = q_{a_i, a_{i+1}} (a_1 \dots a_{i-1} a_{i+1} a_i a_{i+2} \dots a_n)$$

for $a_i \in A$.

Example 6.16 The matrices of \mathcal{T}_2 and \mathcal{T}_3 considered as operators on the space $K a_1 a_1 a_2 \oplus K a_1 a_2 a_1 \oplus K a_2 a_1 a_1$ with respect to this action are given by

$$\mathcal{T}_2 = \begin{pmatrix} 1 + q_{a_1, a_1} & 0 & 0 \\ 0 & 1 & q_{a_1, a_2} \\ 0 & q_{a_2, a_1} & 1 \end{pmatrix}, \quad \mathcal{T}_3 = \begin{pmatrix} 1 & q_{a_1, a_2} & q_{a_1, a_2}^2 \\ q_{a_2, a_1} + q_{a_1, a_1} q_{a_2, a_1} & 1 & 0 \\ 0 & q_{a_2, a_1} q_{a_1, a_1} & 1 + q_{a_1, a_1} \end{pmatrix}.$$

This subsection will be devoted to the study of the determinant of \mathcal{U}_n considered as an operator acting on words of fixed multihomogeneity. According to the results of Section 6.3.2, one can compute this determinant if one knows the values of

$$\det(1 - s_n^2 s_{n-1} \dots s_m) \quad \text{and} \quad \det(1 - s_n s_{n-1} \dots s_m)$$

for all $m < n$. But for the representation under consideration,

$$\det(1 - s_n^2 s_{n-1} \dots s_m) = \det(1 - s_{n-m+1}^2 s_{n-m} \dots s_1),$$

$$\det(1 - s_n s_{n-1} \dots s_m) = \det(1 - s_{n-m+1} s_{n-m} \dots s_1),$$

for $1 \leq m \leq n-1$. Hence it is sufficient to compute the determinants of $1 - s_{n-1} s_{n-2} \dots s_1$ and $1 - s_{n-1}^2 s_{n-2} \dots s_1$. The following proposition gives an answer to this question by providing explicit formulas for the characteristic polynomials $\det(1 - x s)$ of the elements $s = s_n s_{n-1} \dots s_1$ and $s = s_n^2 s_{n-1} \dots s_1$.

For $I \in \mathbb{N}^{(A)}$, let $K\langle A \rangle_I$ be the multihomogenous component of multidegree I of $K\langle A \rangle$. Every braid $s \in \mathcal{B}_{|I|-1}$ stabilizes $K\langle A \rangle_I$. We can therefore consider s as an operator of $K\langle A \rangle_I$. The characteristic polynomial of this operator will be denoted by $P_I(s; x)$. Finally, let us set

$$q(I, J) = \prod_{a,b \in A} q_{a,b}^{I_a \times J_b} \quad \text{and} \quad q(I) = \prod_{a \in A} q_{a,a}^{I_a}$$

for $I = (I_a)_{a \in A}$ and $J = (J_a)_{a \in A}$ of $\mathbb{N}^{(A)}$.

Proposition 6.17 For $n \geq 1$ and $I \in \mathbb{N}^{(A)}$ of weight $|I| = n$, one has

$$P_I(s_{n-1} s_{n-2} \dots s_1; x) = \prod_{\substack{I=kJ \\ k \in \mathbb{N}}} (x^{|J|} - \frac{q(J, J)^k}{q(J)})^{l_J},$$

$$P_I(s_{n-1}^2 s_{n-2} \dots s_1; x) = \prod_{\substack{I=kJ+\varepsilon_a \\ k \in \mathbb{N}, a \in A}} (x^{|J|} - \frac{q(J, J)^k q(J, \varepsilon_a) q(\varepsilon_a, J)}{q(J)})^{l_J},$$

where $(\varepsilon_a) = \delta_{a,b}$ and where l_J denotes the dimension of the multihomogeneous component of multihomogeneity J of the free Lie algebra $L(A)$.

Example 6.18 Consider the multidegree $I = (2, 2, 0, 0, \dots)$. In this case, the matrix of the operator $s_3 s_2 s_1$ in the basis $\{a_1 a_1 a_2 a_2, a_1 a_2 a_1 a_2, a_1 a_2 a_2 a_1, a_2 a_1 a_1 a_2, a_2 a_1 a_2 a_1, a_2 a_2 a_1 a_1\}$ of $K\langle A \rangle_I$ is

$$M_{s_3 s_2 s_1} = \begin{pmatrix} 0 & 0 & q_{11} q_{21}^2 & 0 & 0 & 0 \\ 0 & 0 & 0 & 0 & q_{11} q_{21}^2 & 0 \\ 0 & 0 & 0 & 0 & 0 & q_{11} q_{21}^2 \\ q_{12}^2 q_{22} & 0 & 0 & 0 & 0 & 0 \\ 0 & q_{12}^2 q_{22} & 0 & 0 & 0 & 0 \\ 0 & 0 & 0 & q_{12}^2 q_{22} & 0 & 0 \end{pmatrix}$$

where we write for convenience $q_{i,j}$ in place of q_{a_i, a_j} . Then,

$$P_I(s_3 s_2 s_1; x) = (x^4 - q_{21}^4 q_{12}^4 q_{11}^2 q_{22}^2) (x^2 - q_{21}^2 q_{12}^2 q_{11} q_{22})$$

according to the first formula of the proposition.

As an illustration, we can give an expression of the characteristic polynomial of the permutation $\sigma_{n-1} \dots \sigma_1$ in an irreducible representation V_λ of \mathfrak{S}_n .

Corollary 6.19 *Let λ be a partition of n . The characteristic polynomial of the permutation $\sigma_{n-1} \dots \sigma_1$ in the irreducible representation V_λ of \mathfrak{S}_n is*

$$P_{V_\lambda}(\sigma_{n-1} \dots \sigma_1; x) = \prod_{\mu} \left(\prod_{\lambda=kI, k \in \mathbb{N}} (x^{|\lambda|} - 1)^{l_I} \right)^{\langle s_\lambda, m_\mu \rangle}$$

where $s_\lambda = \sum_{\mu} \langle s_\lambda, m_\mu \rangle h_\mu$ denotes the decomposition of the Schur function s_λ on the basis of complete symmetric functions.

Proof — For a $K[\mathfrak{S}_n]$ -module V and for $s \in \mathfrak{S}_n$, denote by $P_V(s; x)$ the characteristic polynomial of s in the representation V . The corollary follows from the property

$$P_{V+W}(s; x) = P_V(s; x) P_W(s; x)$$

and from the fact that the characteristic polynomial of $\sigma_{n-1} \dots \sigma_1$ in the permutation representation S^λ of \mathfrak{S}_n whose Frobenius characteristic is h_λ is given by

$$P_{S^\lambda}(\sigma_{n-1} \dots \sigma_1; x) = \prod_{\lambda=kI, k \in \mathbb{N}} (x^{|\lambda|} - 1)^{l_I}$$

according to Proposition 6.17. □

This gives the characteristic polynomial of any permutation $\sigma_{i-1} \sigma_{i-2} \dots \sigma_1$ in the regular representation of \mathfrak{S}_n ,

$$P_{\mathfrak{S}_n}(\sigma_{i-1} \dots \sigma_1; x) = P_{\mathfrak{S}_i}(\sigma_{i-1} \dots \sigma_1; x)^{n!/i!}.$$

tation of \mathfrak{S}_n is a product of cyclotomic polynomials. Here is a table of these polynomials for $n \leq 6$.

representation	characteristic polynomial
2	$x - 1$
11	$x + 1$
3	$x - 1$
21	$1 + x + x^2$
111	$x - 1$
4	$x - 1$
31	$(x - 1)(x^2 + 1)$
22	$x^2 - 1$
211	$x^3 + x^2 + x + 1$
1111	$x + 1$
5	$x - 1$
41	$x^4 + x^3 + x^2 + x + 1$
32	$x^5 - 1$
311	$(x^5 - 1)(x - 1)$
221	$x^5 - 1$
2111	$x^4 + x^3 + x^2 + x + 1$
11111	$x - 1$
6	$x - 1$
51	$x^5 - x^4 + x^3 - x^2 + x - 1$
42	$(x^6 - 1)(x^3 + 1)$
411	$(x + 1)(x^6 - 1)(x^3 - 1)$
33	$(x^3 - 1)(x^2 - 1)$
321	$(x^4 + x^2 + 1)^3(x^2 - 1)^2$
3111	$(x - 1)(x^6 - 1)(x^3 + 1)$
222	$(x^3 + 1)(x^2 - 1)$
2211	$(x^6 - 1)(x^3 - 1)$
21111	$x^5 + x^4 + x^3 + x^2 + x + 1$
111111	$x + 1$

6.4 Diagonal hyperplane arrangements

6.4.1 The quantum bilinear form B_n

Varchenko associated to every real configuration \mathcal{C} of hyperplanes² a bilinear form $B_{\mathcal{C}}$, called the *quantum bilinear form* of \mathcal{C} , which is defined as follows. One first associates to each hyperplane H of \mathcal{C} a *weight* a_H in some fixed commutative ring. An *edge* of \mathcal{C} is any nonempty intersection of some subset of the hyperplanes of \mathcal{C} . The weight a_E of an edge E is defined as the product of the weights of all the hyperplanes containing E . The set of all edges of \mathcal{C} is denoted by $\mathcal{E}_{\mathcal{C}}$.

The connected components of the complement of the hyperplanes of \mathcal{C} are called *domains*. Denote by $\mathcal{D}_{\mathcal{C}}$ the set of all domains of \mathcal{C} . Let also $A_{\mathcal{C}}$ be the ring of polynomials in the commutative variables $(a_H)_{H \in \mathcal{C}}$. The quantum bilinear form $B_{\mathcal{C}}$ associated with \mathcal{C} is the bilinear form on the space $M_{\mathcal{C}}$ of the $A_{\mathcal{C}}$ -linear combinations of the domains of $\mathcal{D}_{\mathcal{C}}$ which is defined by

$$B_{\mathcal{C}}(P, Q) = \prod a_H ,$$

² A configuration of hyperplanes is any *finite* set of hyperplanes in some affine or projective space.

Varchenko showed that the determinant of the form $B_{\mathcal{C}}$ is given by the following formula

$$\det B_{\mathcal{C}} = \prod_{E \in \mathcal{E}_{\mathcal{C}}} (1 - a_E^2)^{m(E)} \quad (41)$$

where $m(E)$ is an integer, called the multiplicity of the edge E (see Section 2 of [38] for more details).

Consider now the configuration \mathcal{D}_n of diagonal hyperplanes: it consists of the hyperplanes H_{ij} of \mathbb{R}^n defined by $x_i = x_j$ for $1 \leq i < j \leq n$. Let a_{ji} be the weight of the hyperplane H_{ij} . Here, the domains are the cones P_{σ} defined by

$$P_{\sigma} = \{ (x_1, \dots, x_n) \in \mathbb{R}^n, x_{\sigma(1)} < x_{\sigma(2)} < \dots < x_{\sigma(n)} \}$$

for all permutations σ of \mathfrak{S}_n . The quantum bilinear form $B_{\mathcal{D}_n} = B_n$ associated with \mathcal{D}_n can therefore be considered as a bilinear form on $\mathbb{Z}[a_{ji}][\mathfrak{S}_n]$. The matrix of B_n is given by

$$B_n(\sigma, \tau) = \prod_{\substack{(\sigma^{-1}(i) - \sigma^{-1}(j))(\tau^{-1}(i) - \tau^{-1}(j)) < 0 \\ 1 \leq i < j \leq n}} a_{ji} \quad (42)$$

for $\sigma, \tau \in \mathfrak{S}_n$. In other words, the entry of order (σ, τ) of B_n is obtained by taking the products of all a_{ji} for which the pair ji does not appear in the same order in τ and σ , *i.e.* for which $\sigma = \dots i \dots j \dots$ and $\tau = \dots j \dots i \dots$ (or the converse). The bilinear form B_n can also be interpreted as the contravariant form of a suitable quantum group (*cf.* [34]).

Varchenko's formula (41) reduces here to

$$\det B_n = \prod_{I_k} (1 - \prod_{(j,i) \in I_k} a_{ji}^2)^{n_k} \quad (43)$$

where I_k runs through all subsets of $k(k-1)/2$ elements of $\{(j, i), 1 \leq i < j \leq n\}$ for $k \in [2, n]$ and where n_k denotes the integer

$$n_k = \frac{(n-k+1)n!}{k(k-1) \binom{n(n-1)/2}{k(k-1)/2}}.$$

Finally, relation (42) shows that B_n is the matrix of an element of $\mathbb{Z}[a_{ji}][\mathfrak{S}_n]$ (considered as an operator in the regular representation of \mathfrak{S}_n) iff $a_{ji} = a_{kl}$ for all $j > i$ and $k > l$. If we call q this common value, we see that $B_n = U_n(q)$. Thus, $U_n(q)$ has the same matrix as the quantum bilinear form associated with the diagonal hyperplane arrangement when every hyperplane has the same weight q and one sees that Corollary 4.13 can be also obtained by specializing formula (43).

Example 6.21 The matrix of the quantum bilinear form B_3 is

$$\begin{array}{c} \begin{array}{cccccc} & 123 & 132 & 213 & 231 & 312 & 321 \\ \begin{array}{c} 123 \\ 132 \\ 213 \\ 231 \\ 312 \\ 321 \end{array} & \left(\begin{array}{cccccc} 1 & a_{32} & a_{21} & a_{21}a_{31} & a_{31}a_{32} & a_{21}a_{31}a_{32} \\ a_{32} & 1 & a_{21}a_{32} & a_{21}a_{31}a_{32} & a_{31} & a_{21}a_{31} \\ a_{21} & a_{21}a_{32} & 1 & a_{31} & a_{21}a_{31}a_{32} & a_{31}a_{32} \\ a_{21}a_{31} & a_{21}a_{31}a_{32} & a_{31} & 1 & a_{21}a_{32} & a_{32} \\ a_{31}a_{32} & a_{31} & a_{21}a_{31}a_{32} & a_{21}a_{32} & 1 & a_{21} \\ a_{21}a_{31}a_{32} & a_{21}a_{31} & a_{31}a_{32} & a_{32} & a_{21} & 1 \end{array} \right) \end{array} \end{array}.$$

$$\det B_3 = (1 - a_{21}^2)^2 (1 - a_{31}^2)^2 (1 - a_{32}^2)^2 (1 - (a_{21}a_{31}a_{32})^2) .$$

B_3 is the matrix of an element of $\mathbb{Z}[a_{21}, a_{31}, a_{32}][\mathfrak{S}_3]$ iff $a_{21} = a_{31} = a_{32}$.

6.4.2 A decomposition of B_n

We shall now see that one can recover formula (43) from a factorization of B_n which is in fact a specialization of Corollary 6.14. We shall therefore define first a representation μ_n of the braid group \mathcal{B}_n . For $n \geq 2$ and $i \in [1, n-1]$, consider the $\mathfrak{S}_n \times \mathfrak{S}_n$ matrix $S_i^{(n)}$ defined by

$$S_i^{(n)}(\sigma, \tau) = \begin{cases} \tilde{a}_{\sigma(i)\sigma(i+1)} & \text{if } \tau = \sigma\sigma_i , \\ 0 & \text{in all other cases ,} \end{cases} \quad (44)$$

where \tilde{a}_{ij} denotes a_{ji} if $j > i$ and a_{ij} if $j < i$. These matrices are obtained from the diagonal solutions $R(e_i \otimes e_j) = \tilde{a}_{ij}e_i \otimes e_j$ of the Yang-Baxter equation by restriction of \check{R} to the $n!$ -dimensional subspace of $V^{\otimes n}$ spanned by multilinear elements $e_{\sigma(1)} \otimes \cdots \otimes e_{\sigma(n)}$, $\sigma \in \mathfrak{S}_n$. Thus,

$$\begin{cases} S_i^{(n)} S_j^{(n)} = S_j^{(n)} S_i^{(n)} & \text{if } |i - j| > 1 , \\ S_i^{(n)} S_{i+1}^{(n)} S_i^{(n)} = S_{i+1}^{(n)} S_i^{(n)} S_{i+1}^{(n)} & \text{if } i \in [1, n-2] \end{cases}$$

so that

$$\mu_n(s_i) = S_i^{(n)}$$

defines a representation of \mathcal{B}_n . The matrix of Varchenko's quantum bilinear form is then

$$B_n = \mu_n(\mathcal{U}_n) = \sum_{\sigma \in \mathfrak{S}_n} \mu_n(T_\sigma) , \quad (45)$$

the results of Section 6.3 can be applied. The images $T_k^{(n)} = \mu_n(\mathcal{T}_k)$ are the $\mathfrak{S}_n \times \mathfrak{S}_n$ matrices

$$T_k^{(n)} = I + S_{k-1}^{(n)} + S_{k-1}^{(n)} S_{k-2}^{(n)} + \cdots + S_{k-1}^{(n)} S_{k-2}^{(n)} \cdots S_1^{(n)} \quad (46)$$

whose elements are

$$T_k^{(n)}(\sigma, \tau) = \begin{cases} 1 & \text{if } \sigma = \tau , \\ \prod_{i=l}^{k-1} \tilde{a}_{\sigma(k)\sigma(i)} & \text{if } \tau = \sigma\sigma_{k-1} \cdots \sigma_l \quad \text{with } l = 1, k-1 , \\ 0 & \text{in all other cases .} \end{cases}$$

In other words, $T_k^{(n)}$ is the matrix obtained from B_n by taking all entries indexed by a pair of the form $(\sigma, \sigma\sigma_{k-1} \cdots \sigma_l)$ with some $l \in [1, n]$ and by replacing all other entries by 0. The first formula of Corollary 6.14 reduces then to the following one:

Proposition 6.22

$$B_n = T_2^{(n)} \cdots T_n^{(n)} . \quad (47)$$

$$T_2^{(3)} = \begin{array}{c} 123 \\ 132 \\ 213 \\ 231 \\ 312 \\ 321 \end{array} \begin{pmatrix} 1 & 0 & a_{21} & 0 & 0 & 0 \\ 0 & 1 & 0 & 0 & a_{31} & 0 \\ a_{21} & 0 & 1 & 0 & 0 & 0 \\ 0 & 0 & 0 & 1 & 0 & a_{32} \\ 0 & a_{31} & 0 & 0 & 1 & 0 \\ 0 & 0 & 0 & a_{32} & 0 & 1 \end{pmatrix},$$

$$T_3^{(3)} = \begin{array}{c} 123 \\ 132 \\ 213 \\ 231 \\ 312 \\ 321 \end{array} \begin{pmatrix} 1 & a_{32} & 0 & 0 & a_{31}a_{32} & 0 \\ a_{32} & 1 & a_{21}a_{32} & 0 & 0 & 0 \\ 0 & 0 & 1 & a_{31} & 0 & a_{31}a_{32} \\ a_{21}a_{31} & 0 & a_{31} & 1 & 0 & 0 \\ 0 & 0 & 0 & a_{21}a_{32} & 1 & a_{21} \\ 0 & a_{21}a_{31} & 0 & 0 & a_{21} & 1 \end{pmatrix}.$$

The second formula of Corollary 6.14 applied to Varchenko's quantum bilinear form will give us a factorization of the matrix $T_k^{(n)}$ which reduces to the decomposition (23) when all the a_{ji} are specialized to q . As in the $T_n(q)$ case, it will give us a closed formula for the inverse of $T_k^{(n)}$ (and hence of B_n) and for its determinant.

For $n \geq 2$, $k \in [2, n]$, $i \in [2, k]$ and $j \in [1, k-1]$, we define $\mathfrak{S}_n \times \mathfrak{S}_n$ -matrices $\Gamma_{\gamma_{i,k}}^{(n,k)}$ and $\bar{\Gamma}_{\gamma'_{j,k}}^{(n,k)}$ by

$$\Gamma_{\gamma_{i,k}}^{(n,k)}(\sigma, \tau) = \begin{cases} \tilde{a}_{\sigma(k-1)\sigma(k)}^2 \prod_{l=k-i+1}^{k-2} \tilde{a}_{\sigma(k-1)\sigma(l)} & \text{if } \tau = \sigma\gamma_{i,k}, \\ 0 & \text{in all other cases,} \end{cases}$$

$$\bar{\Gamma}_{\gamma'_{j,k}}^{(n,k)}(\sigma, \tau) = \begin{cases} \prod_{l=k-j}^{k-1} \tilde{a}_{\sigma(k)\sigma(l)} & \text{if } \tau = \sigma\gamma'_{j,k}, \\ 0 & \text{in all other cases,} \end{cases}$$

where

$$\gamma_{i,k} = (1 \dots k-i \ k-i-1 \ k-i+1 \dots k-2 \ k \dots n),$$

$$\gamma'_{j,k} = (1 \dots k-j-1 \ k \ k-j \dots k-1 \ k+1 \dots n).$$

The specialization of the second identity of Corollary 6.14 gives here the following factorization.

Proposition 6.24 *For $n \geq 2$ and $k \in [2, n]$,*

$$T_k^{(n)} = (I - \Gamma_{\gamma_{k,k}}^{(n,k)}) \dots (I - \Gamma_{\gamma_{2,k}}^{(n,k)}) (I - \bar{\Gamma}_{\gamma'_{1,k}}^{(n,k)})^{-1} \dots (I - \bar{\Gamma}_{\gamma'_{k-1,k}}^{(n,k)})^{-1}. \quad (48)$$

below

$$I - \Gamma_{(213)}^{(3,3)} = \begin{pmatrix} 123 & 132 & 213 & 231 & 312 & 321 \\ 1 & 0 & -a_{32}^2 a_{21} & 0 & 0 & 0 \\ 0 & 1 & 0 & 0 & -a_{32}^2 a_{31} & 0 \\ -a_{31}^2 a_{21} & 0 & 1 & 0 & 0 & 0 \\ 0 & 0 & 0 & 1 & 0 & -a_{31}^2 a_{32} \\ 0 & -a_{21}^2 a_{31} & 0 & 0 & 1 & 0 \\ 0 & 0 & 0 & -a_{21}^2 a_{32} & 0 & 1 \end{pmatrix},$$

$$I - \Gamma_{(123)}^{(3,3)} = \begin{pmatrix} 123 & 132 & 213 & 231 & 312 & 321 \\ 1 - a_{32}^2 & 0 & 0 & 0 & 0 & 0 \\ 0 & 1 - a_{32}^2 & 0 & 0 & 0 & 0 \\ 0 & 0 & 1 - a_{31}^2 & 0 & 0 & 0 \\ 0 & 0 & 0 & 1 - a_{31}^2 & 0 & 0 \\ 0 & 0 & 0 & 0 & 1 - a_{21}^2 & 0 \\ 0 & 0 & 0 & 0 & 0 & 1 - a_{21}^2 \end{pmatrix},$$

$$I - \bar{\Gamma}_{(132)}^{(3,3)} = \begin{pmatrix} 123 & 132 & 213 & 231 & 312 & 321 \\ 1 & -a_{32} & 0 & 0 & 0 & 0 \\ -a_{32} & 1 & 0 & 0 & 0 & 0 \\ 0 & 0 & 1 & -a_{31} & 0 & 0 \\ 0 & 0 & -a_{31} & 1 & 0 & 0 \\ 0 & 0 & 0 & 0 & 1 & -a_{21} \\ 0 & 0 & 0 & 0 & -a_{21} & 1 \end{pmatrix},$$

$$I - \bar{\Gamma}_{(312)}^{(3,3)} = \begin{pmatrix} 123 & 132 & 213 & 231 & 312 & 321 \\ 1 & 0 & 0 & 0 & -a_{31} a_{32} & 0 \\ 0 & 1 & -a_{21} a_{32} & 0 & 0 & 0 \\ 0 & 0 & 1 & 0 & 0 & -a_{31} a_{32} \\ -a_{21} a_{31} & 0 & 0 & 1 & 0 & 0 \\ 0 & 0 & 0 & -a_{21} a_{32} & 1 & 0 \\ 0 & -a_{21} a_{31} & 0 & 0 & 0 & 1 \end{pmatrix}.$$

In this case, (48) reduces to

$$T_3^{(3)} = (I - \Gamma_{(213)}^{(3,3)}) (I - \Gamma_{(123)}^{(3,3)}) (I - \bar{\Gamma}_{(132)}^{(3,3)})^{-1} (I - \bar{\Gamma}_{(312)}^{(3,3)})^{-1},$$

and

$$T_2^{(3)} = (I - \Gamma_{(123)}^{(3,2)}) (I - \bar{\Gamma}_{(213)}^{(3,2)})^{-1}.$$

Note 6.26 One can check that

$$(I - \Gamma_{\gamma_{i,k}}^{(n,k)}) \left(\sum_{l=0}^{i-2} (\Gamma_{\gamma_{i,k}}^{(n,k)})^l \right) = \Delta_i^{(n,k)} \quad (49)$$

$$\Delta_i^{(n,k)}(\sigma, \tau) = \begin{cases} 1 - \prod_{k-i+1 \leq r < s \leq k} \tilde{a}_{\sigma(r)\sigma(s)}^2 & \text{if } \sigma = \tau, \\ 0 & \text{if } \sigma \neq \tau. \end{cases}$$

One has $\Delta_n^{(n,n)} = (1 - \prod_{1 \leq i < j \leq n} a_{ji}^2) I$, and

$$(I - \bar{\Gamma}_{\gamma'_{j,k}}^{(n,k)}) \left(\sum_{l=0}^j (\bar{\Gamma}_{\gamma'_{j,k}}^{(n,k)})^l \right) = \Delta_{j+1}^{(n,k)}. \quad (50)$$

Formulas (49) and (50) both give a more explicit version of decomposition (48) and a closed form for the inverse of $T_k^{(n)}$ (and hence also for the inverse of B_n).

Note 6.27 It can also be checked that

$$\det (I - \Gamma_{\gamma_{i,k}}^{(n,k)}) = \left(\prod_{\substack{I \subset [1,n] \\ |I|=i}} \left(1 - \prod_{\substack{r,s \in I \\ r < s}} a_{sr}^2 \right) \right)^{m_{n,i}} \quad (51)$$

where

$$m_{n,i} = \frac{i n!}{2 \binom{i}{2} \binom{n}{i}} = \frac{(n-i)! i!}{i-1}.$$

On the other hand,

$$\det (I - \bar{\Gamma}_{\gamma'_{j,k}}^{(n,k)}) = \left(\prod_{\substack{I \subset [1,n] \\ |I|=j+1}} \left(1 - \prod_{\substack{r,s \in I \\ r < s}} a_{rs}^2 \right) \right)^{m'_{n,j}} \quad (52)$$

with

$$m'_{n,j} = \frac{j n!}{2 \binom{j+1}{2} \binom{n}{j+1}} = (n-j-1)! j!.$$

It is interesting to observe that (51) and (52) show that the determinants of $I - \Gamma_{\gamma_{i,k}}^{(n,k)}$ and $I - \bar{\Gamma}_{\gamma'_{j,k}}^{(n,k)}$ are independent of k .

6.5 The t -shuffle operator in the Hecke algebra

The representations of the braid group considered in the foregoing sections were all obtained from trivial (diagonal) solutions of the Yang-Baxter equation. The simplest non-trivial solutions are those which factorize through the Hecke algebra $H_n(q)$. It is therefore of interest to consider the element

$$V_n(t) = \sum_{\sigma \in \mathfrak{S}_n} t^{\ell(\sigma)} T_\sigma$$

of $H_n(q) \otimes \mathbb{C}[t]$, *i.e.* the image of \mathcal{U}_n under the morphism from the braid group \mathcal{B}_n into $H_n(q)$ defined by $s_i \rightarrow t T_i$. All the factorizations of Section 6.3.2 are valid for $V_n(t)$, and we shall also obtain an explicit formula for the determinant of this operator, which can be regarded as a q -analogue of the determinant formula for $U_n(t)$.

of the elements

$$1 - T_{n-1} \dots T_1 \quad \text{and} \quad 1 - T_{n-1}^2 \dots T_1$$

considered as operators of the (left or right) regular representation of $H_n(q)$. But one has

$$\det(1 - T_{n-1} \dots T_1) = \left(\prod_{\lambda \vdash n} P_{V_\lambda}(T_{n-1} \dots T_1; x)^{f_\lambda} \right) \Big|_{x=1},$$

$$\det(1 - T_{n-1}^2 \dots T_1) = \left(\prod_{\lambda \vdash n} P_{V_\lambda}(T_{n-1}^2 \dots T_1; x)^{f_\lambda} \right) \Big|_{x=1},$$

where f_λ is the number of standard Young tableaux of shape λ and where $P_{V_\lambda}(s; x)$ is the characteristic polynomial $\det(1 - xs)$ of $s \in H_n(q)$ in the irreducible representation of $H_n(q)$ indexed by λ (see *e.g.* [5]).

Let $K_{\lambda, \mu} = \langle s_\lambda, h_\mu \rangle$ be the Kostka numbers. The following proposition expresses the characteristic polynomial of $T_{n-1} \dots T_1$ in the q -Specht module $V_\lambda(q)$ in terms of the corresponding polynomial for the symmetric group, as computed in Section 6.3.3.

Proposition 6.28 *Let λ be a partition of n and $V_\lambda(q)$ be the corresponding irreducible representation of $H_n(q)$. Then, the characteristic polynomial of $T_{n-1} T_{n-2} \dots T_1$ in $V_\lambda(q)$ is*

$$P_{V_\lambda(q)}(T_{n-1} T_{n-2} \dots T_1; x) = P_{V_\lambda(1)}(\sigma_{n-1} \sigma_{n-2} \dots \sigma_1; q^{(n-1)\alpha_\lambda} x)$$

where $V_\lambda(1)$ is the Specht module for the symmetric group, and $\alpha_\lambda = K_{\lambda, 21^{n-2}} / K_{\lambda, 1^n}$.

Proof — The existence of a homogeneity factor between the characteristic polynomials of $T_{n-1} \dots T_1$ and $\sigma_{n-1} \dots \sigma_1$ can be seen on the Kazhdan-Lusztig model of the irreducible $H_n(q)$ -module V_λ , and this factor is determined by the equality

$$\det_{V_\lambda}(T_{n-1} \dots T_1) = (\det_{V_\lambda} T_1)^{n-1} = q^{(n-1)K_{\lambda, 21^{n-2}}}$$

which is easily checked. □

Corollary 6.29 *The characteristic polynomial of $T_{n-1}^2 T_{n-2} \dots T_1$ in the irreducible $H_n(q)$ -module $V_\lambda(q)$ is equal up to a homogeneity factor to the characteristic polynomial of the corresponding permutation in the irreducible \mathfrak{S}_n -module $V_\lambda(1)$, i.e.*

$$P_{V_\lambda}(T_{n-1}^2 T_{n-2} \dots T_1; x) = P_{W_\lambda}(\sigma_{n-2} \dots \sigma_1; q^{n\alpha_\lambda} x)$$

where $\alpha_\lambda = K_{\lambda, 21^{n-2}} / K_{\lambda, 1^n}$.

Example 6.30 For $|\lambda| \leq 4$, these polynomials are

λ	$P_{V_\lambda}(T_{n-1} \dots T_1; x)$	$P_{V_\lambda}(T_{n-1}^2 T_{n-2} \dots T_1; x)$
2	$1 - xq$	$1 - xq^2$
11	$1 + x$	$1 - x$
3	$1 - xq^2$	$1 - xq^3$
21	$1 + xq + x^2q^2$	$1 - q^3x^2$
111	$1 - x$	$1 + x$
4	$1 - xq^3$	$1 - q^4x$
31	$1 - xq + x^2q^2 - x^3q^3$	$1 - x^3q^4$
22	$1 - x^2q^3$	$1 + xq^2 + x^2q^4$
2111	$1 + xq^2 + x^2q^4 + x^3q^6$	$1 - q^8x^3$
1111	$1 + x$	$1 - x$

$$\diamond_i(t) = 1 + tT_i$$

for $i \in [1, n-1]$. These elements interpolate between two interesting elements of $H_n(q)$

$$\diamond_i(1) = \square_i = 1 + T_i, \quad \diamond_i(-1/q) = \frac{-1}{q} \nabla_i = \frac{-1}{q} (T_i - q)$$

(see [5] for more details). The operators $\diamond_i(t)$ satisfy Yang-baxter type relations

$$\diamond_i(t) \left(\diamond_{i+1}(t) - \frac{1+t(q-1)}{2+t(q-1)} \right) \diamond_i(t) = \diamond_{i+1}(t) \left(\diamond_i(t) - \frac{1+t(q-1)}{2+t(q-1)} \right) \diamond_{i+1}(t),$$

and as a special case of a construction of Cherednik, one can associate with the maximal permutation ω_n of \mathfrak{S}_n the element

$$\diamond_{\omega_n} = \diamond_1 \left((\diamond_2 - f_{13}) \diamond_1 \right) \dots \left((\diamond_{n-1} - f_{1n}) \dots (\diamond_2 - f_{13}) \diamond_1 \right)$$

of $H_n(q) \otimes \mathbb{C}(t)$, where

$$f_{1k} = [1]_{t,q} \frac{[1]_{t,q}^{n-1} - 1}{[1]_{t,q}^n - 1}$$

with $[1]_{t,q} = 1 + t(q-1)$. It would be interesting to clarify the relation between \diamond_{ω_n} and $V_n(t)$. These elements are clearly related in the two extreme cases $t = 1$ and $t = -1/q$ but we do not know if such relations still exist in the general case.

7.1 Deformations and Lie idempotents

This section is devoted to a special case of the deformations of the usual Cauchy and convolution products of $K\langle A \rangle$ obtained by means of noncommutative symmetric functions (*cf.* Section 3.2). We are here interested in the case where the set of primitive elements of the deformed algebra is still the free Lie algebra $L(A)$. This case is of some importance, since it leads to a complete understanding of a class of interesting decompositions of the free associative algebra.

We use the notations of Section 3.2. We will restrict the families $F = (F_n)_{n \geq 1}$ used to construct the deformations to those satisfying for all n

$$F_n * \Psi_n = k_{F_n} \Psi_n$$

where k_{F_n} is a constant. These equations have of course many solutions. An interesting class is given by $F_n = S_n(XA)$, where X is a totally ordered alphabet (which can be virtual, *i.e.* defined by the specialization of a transcendence basis of $QSym$). Indeed, the following result shows that such a family satisfies to the desired property.

Proposition 7.1 *Let X be a totally ordered commutative alphabet, let A be a noncommutative alphabet and let π_n be a homogenous element of weight n in $L(\Psi)$. Then,*

$$S_n(XA) * \pi_n(A) = \psi_n(X) \pi_n(A)$$

for all $n \geq 1$, where $\psi_n(X)$ is the usual power sum symmetric function.

Proof — Using Proposition 2.1, we can write

$$\begin{aligned} \sigma(XA; t) * \pi_n(A) &= \mu_\infty \left(\left(\bigotimes_{x \in X} \sigma(A; xt) \right) * \Delta^\infty(\pi_n) \right) \\ &= \mu_\infty \left(\left(\bigotimes_{x \in X} \sigma(A; xt) \right) * \sum 1 \otimes \dots \otimes 1 \otimes \pi_n \otimes 1 \dots \right) \end{aligned}$$

from which it follows that

$$\sigma(XA; t) * \pi_n(A) = \sum_{x \in X} (S_n * \pi_n) x^n t^n = \left(\sum_{x \in X} x^n \right) \pi_n t^n = \psi_n(X) \pi_n t^n .$$

□

Let now X denote a fixed totally ordered commutative alphabet. According to Section 3, one can deform the ordinary Cauchy product of $K\langle A \rangle$ by means of the family $(\alpha(S_n(XA)))_{n \geq 1}$. The product \odot_X obtained by this method is here given by

$$u \odot_X v = \left((u \cdot \alpha(S_n(XA))^{*-1})(v \cdot \alpha(S_m(XA))^{*-1}) \right) \cdot \alpha(S_{n+m}(XA))$$

for words u and v of respective lengths n and m . The associated convolution algebra is still equal here to Solomon's descent algebra. It can be interpreted as the K -vector space

by

$$U \cdot_X V = S_{n+m}(XA) * (UV)$$

for $U \in \mathbf{Sym}_n$ and $V \in \mathbf{Sym}_m$ (cf. Section 3.2). The deformed interpretation morphism α_X is here

$$\alpha_X(U) = S_n(XA) * U * S_n\left(\frac{1}{X}A\right) = S_n(XA) * U\left(\frac{1}{X}A\right),$$

and in particular the interpretation of the Eulerian Lie idempotent Φ_n is

$$\alpha_X(\Phi_n) = S_n(XA) * \Phi_n\left(\frac{1}{X}A\right) = \psi_n(X) \Phi_n\left(\frac{1}{X}A\right) = \frac{\Phi_n\left(\frac{1}{X}A\right)}{\psi_n\left(\frac{1}{X}\right)},$$

according to Proposition 7.1. This situation is interesting since the forthcoming proposition shows that every Lie idempotent of Solomon's descent algebra can be described in this way.

Proposition 7.2 *Let A be a noncommutative alphabet and let π_n be an arbitrary homogeneous Lie idempotent of order n in $L(\Psi)$. The following properties are equivalent:*

1. Π_n is a homogenous Lie idempotent of order n in $L(\Psi)$.
2. There exists a virtual totally ordered commutative alphabet X such that

$$\Pi_n = \frac{\pi_n(XA)}{\psi_n(X)},$$

where ψ_n is the usual power sum symmetric function.

Proof — (2 \implies 1) follows essentially from Proposition 7.1. Indeed this allows to write

$$\Pi_n * \pi_n = \frac{1}{\psi_n(X)} \pi_n(XA) * \pi_n = \frac{1}{\psi_n(X)} \pi_n * S_n(XA) * \pi_n = \pi_n * \pi_n = \pi_n.$$

On the other hand,

$$\pi_n * \Pi_n = \frac{1}{\psi_n(X)} \pi_n * \pi_n(XA) = \frac{1}{\psi_n(X)} \pi_n * \pi_n * S_n(XA) = \frac{1}{\psi_n(X)} \pi_n * S_n(XA) = \Pi_n,$$

so that $\pi_n * \Pi_n = \Pi_n$ and $\Pi_n * \pi_n = \pi_n$ for all $n \geq 1$, which implies that Π_n is a Lie idempotent of $L(\Psi)$.

(1 \implies 2) Consider a totally ordered commutative alphabet X . Let $([\pi^L])_{L \in Ly}$ be the Lyndon basis of the free Lie algebra $L(\Psi)$ associated with the generating family $(\pi_n)_{n \geq 1}$ (where Ly denotes the set of Lyndon words over the alphabet \mathbb{N}). From the case $\pi_n = \Psi_n$, one can see that there exists a family $(p_L(X)^{(n)})_{L \in Ly_n}$ of quasi-symmetric functions such that

$$\pi_n(XA) = \sum_{L \in Ly_n} p_L(X) [\pi^L] \tag{53}$$

where Ly_n denotes the set of Lyndon words over \mathbb{N} of weight n . The coefficient $p_{(n)}(X)$ of π_n in this expansion is equal to $\psi_n(X)$, since

$$p_{(n)}(X) \pi_n = \pi_n(XA) * \pi_n = \pi_n * S_n(XA) * \pi_n = \psi_n(X) \pi_n * \pi_n = \psi_n(X) \pi_n,$$

We shall now prove that the family $(p_L(X))_{L \in Ly_n, n \geq 1}$ is a transcendence basis for the algebra $QSym$ of quasi-symmetric functions over X (which is a free commutative algebra according to a result of Malvenuto and Reutenauer [24]). Let (π_I^*) be the dual basis of (π^I) . As shown in [24], the family $(\pi_L^*)_{L \in Ly_n, n \geq 1}$ is a transcendence basis of $QSym$. On the other hand, using the Cauchy formula, one can write

$$S_n(XA) = \sum_{I \vdash n} \pi_I^*(X) \pi^I .$$

Expanding $S_n(A)$ on the basis (π^I) and applying (53), one obtains another expression of $S_n(XA)$ on the (π^I) basis. Identifying the coefficients, one finds

$$\pi_L^* = k_L p_L + \sum_{\substack{L_1, \dots, L_k \\ k \geq 2}} p_{L_1} \cdots p_{L_k}$$

for any Lyndon word L of weight n , the sum being taken over Lyndon words L_1, \dots, L_k of length strictly less than $|L|$ (and whose total length is equal to $|L|$). Also, the constant k_L must be non-zero, as follows from using a simple argument on the cardinality of finite transcendence bases. This shows that $(p_L)_{L \in Ly_n, n \geq 1}$ is a transcendence basis of $QSym$, as required.

Let now Π_n be an arbitrary Lie idempotent in $L(\Psi)$. One can expand it on the Lyndon basis associated with the family (π_n) , *i.e.*

$$\Pi_n = \sum_{L \in Ly_n} q_L [\pi^L] ,$$

where the q_L are scalars. According to the previous discussion, one can now define a totally ordered commutative (virtual) alphabet X by setting $p_L(X) = q_L$ for every $L \in Ly$. Since $q_{(n)}$ is here necessarily equal to 1, it follows that

$$\frac{\pi_n(XA)}{\psi_n(X)} = \frac{\pi_n(XA)}{p_{(n)}(X)} = \frac{\pi_n(XA)}{q_{(n)}} = \pi_n(XA) = \Pi_n ,$$

as required. □

Recall now that the Lie (quasi) idempotent

$$\alpha_X(\Phi_n) = \frac{\Phi_n(\frac{1}{X}A)}{\psi_n(\frac{1}{X})}$$

is the element of \mathbf{Sym}_n corresponding to projection onto the free Lie algebra with respect to the decomposition

$$K\langle A \rangle = K \oplus L(A) \oplus (L(A), L(A))_{\odot_X} \oplus \dots \oplus \underbrace{(L(A), \dots, L(A))_{\odot_X}}_{n \text{ terms}} \oplus \dots , \quad (54)$$

where $(L(A), \dots, L(A))_{\odot_X}$ is the submodule of $K\langle A \rangle$ spanned by the \odot_X -symmetrized products

$$(P_1, \dots, P_n)_{\odot_X} = \frac{1}{n!} \sum_{\sigma \in SG_n} P_{\sigma(1)} \odot_X \dots \odot_X P_{\sigma(n)}$$

of Lie polynomials. Hence it follows from Proposition 7.2 that all Lie idempotents of the descent algebra are the Lie projectors associated to some deformation of the canonical decomposition of $K\langle A \rangle$ given by (54).

In the latter case, the associated interpretation α_q is

$$\alpha_q(F) = S_n\left(\frac{1}{1-q}A\right) * F((1-q)A) .$$

In particular,

$$\alpha_q(\pi^I) = S_n\left(\frac{1}{1-q}A\right) * \pi_n((1-q)A)$$

for every family $(\pi_n)_{n \geq 1}$ of homogeneous Lie idempotents. On the other hand [21]

$$S_n\left(\frac{1}{1-q}A\right) * \pi^I = \sum_{\sigma \in \mathfrak{S}_r} \frac{q^{\text{maj}_I(\sigma)}}{(1-q^{i_{\sigma(1)}})(1-q^{i_{\sigma(1)}+i_{\sigma(2)}}) \dots (1-q^{i_{\sigma(1)}+\dots+i_{\sigma(r)}})} \pi^{\sigma \cdot I} . \quad (55)$$

Hence,

$$\alpha_q(\pi^I) = \sum_{\sigma \in \mathfrak{S}_r} \frac{q^{\text{maj}_I(\sigma)}}{(1-q^{i_{\sigma(1)}})(1-q^{i_{\sigma(1)}+i_{\sigma(2)}}) \dots (1-q^{i_{\sigma(1)}+\dots+i_{\sigma(r)}})} \pi((1-q)A)^{\sigma \cdot I} .$$

But it has been shown in [20] that the limit for $q \rightarrow 1$ of $\pi_n((1-q)A)/(1-q^n)$ is always equal to Ψ_n/n . Thus,

$$\lim_{q \rightarrow 1} \alpha_q(\pi^I) = \sum_{\sigma \in \mathfrak{S}_r} \frac{1}{i_{\sigma(1)}(i_{\sigma(1)} + i_{\sigma(2)}) \dots (i_{\sigma(1)} + \dots + i_{\sigma(r)})} \Psi^{\sigma \cdot I} = E_{\lambda(I)}(\Psi) ,$$

where $\lambda(I)$ denotes the partition obtained by sorting I . Hence the convolution algebra associated with the deformed Cauchy product corresponding to $S_n(A/(1-q))$ degenerates when $q \rightarrow 1$ into the commutative algebra generated by the elements $(E_\lambda(\Psi))_{\lambda \vdash n}$. One should observe that these elements form a family of orthogonal idempotents, similar to those of Garsia and Reutenauer ([9], see also [20]).

7.2 Structure of the multihomogeneous modules associated with Lie idempotents

We first recall some results of [20]. Let $\pi = (\pi_n)_{n \geq 1}$ a family of homogeneous Lie idempotents. One can decompose S_n on the basis (π^I) , say

$$S_n = \sum_I p_I \pi^I$$

where p_I are constants. One associates then with each partition $\lambda = (l_1, \dots, l_r)$ of n the noncommutative symmetric function $E_\lambda(\pi)$ defined by

$$E_\lambda(\pi) = \sum_{\lambda(I)=\lambda} p_I \pi^I ,$$

where $\lambda(I)$ denotes the partition obtained by reordering the components of I . As shown in [20], these elements form a complete system of orthogonal idempotents. When π is the family (Φ_n) of Eulerian idempotents, these idempotents reduce to the family described by Garsia and Reutenauer [9]. In this case, $E_\lambda(\Phi)$ is the projector on the module $(L(A)_{l_1}, \dots, L(A)_{l_r})$ in the decomposition

$$K\langle A \rangle = K \oplus L(A) \oplus (L(A), L(A)) \oplus \dots \oplus \underbrace{(L(A), \dots, L(A))}_{n \text{ terms}} \oplus \dots$$

is not immediately clear. According to previous discussion, one can just say that $E_\lambda(\pi)$ is the projector on $(L(A)_{l_1}, \dots, L(A)_{l_r})_{\odot_X}$ with respect to the decomposition (54) if one interprets the Lie idempotents π_n as $\Phi_n(XA)/\psi_n(X)$ for some totally ordered alphabet X (which is always possible according to Proposition 7.2). It remains however to give a more explicit description of the images of the $E_\lambda(\pi)$, *i.e.* of

$$\text{Im } E_\lambda(\pi) = K\langle A \rangle_{|\lambda|} \cdot \alpha(E_\lambda(\pi)) .$$

This will be done in the next proposition. Before stating it, we introduce some notations. If $\lambda = (\lambda_1, \dots, \lambda_r)$ is a partition of n , we denote by $\lambda \cdot \sigma$ the *composition* of n defined by

$$\lambda \cdot \sigma = (\lambda_{\sigma(1)}, \dots, \lambda_{\sigma(r)}) .$$

We can now give the main result of this subsection.

Proposition 7.4 *Let $\pi = (\pi_n)_{n \geq 1}$ be a family of homogeneous Lie idempotents, with $\pi_n \in \mathbf{Sym}_n$, let $\lambda = (l_1, l_2, \dots, l_r)$ be a partition of n and let*

$$E_\lambda(\pi) = \sum_{\lambda(I)=\lambda} p_I \pi^I$$

be the idempotent associated with λ as above. The image $\text{Im } E_\lambda(\pi)$ of this idempotent is then the module spanned by the polynomials

$$\sum_{\sigma \in \mathfrak{S}_r} p_{\lambda \cdot \sigma} P_{l_{\sigma(1)}} P_{l_{\sigma(2)}} \cdots P_{l_{\sigma(r)}}$$

where P_{l_k} is a homogeneous Lie polynomial of degree l_k .

Proof — The proposition is a special case of the following lemma:

Lemma 7.5 *With the same hypotheses, let*

$$E = \sum_{\lambda(I)=\lambda} p_I \pi^I$$

be an arbitrary linear combination of all π^I indexed by a permutation of λ . The image $\text{Im } E = K\langle A \rangle_{|\lambda|} \cdot \alpha(E)$ of this element is then spanned by the polynomials

$$\sum_{\sigma \in \mathfrak{S}_r} p_{\lambda \cdot \sigma} P_{l_{\sigma(1)}} P_{l_{\sigma(2)}} \cdots P_{l_{\sigma(r)}}$$

where as above, P_{l_k} is a homogeneous Lie polynomial of degree l_k .

Proof of the lemma — Let M be the module defined by

$$M = \left\{ \sum_{\sigma \in \mathfrak{S}_r} p_{\lambda \cdot \sigma} P_{l_{\sigma(1)}} P_{l_{\sigma(2)}} \cdots P_{l_{\sigma(r)}} \mid \forall k \in [1, r], P_{l_k} \in L(A)_{l_k} \right\} .$$

We first prove that $\text{Im } E \subset M$. To get this inclusion, it suffices to show that $\alpha(E) \in M$. This follows from the fact that

$$\alpha(E) = \sum_{\substack{I=(i_1, \dots, i_r) \\ \lambda(I)=\lambda}} p_I \theta_{i_1} \otimes \cdots \otimes \theta_{i_r} .$$

$$\begin{aligned}
\alpha(E) &= \mu \left(\sum_{\substack{I=(i_1, \dots, i_r) \\ \lambda(I)=\lambda}} p_I \vartheta_{i_1} \otimes \dots \otimes \vartheta_{i_r} \right) \circ c(12 \dots n) \\
&= \mu \left(\sum_{\substack{I=(i_1, \dots, i_r) \\ \lambda(I)=\lambda}} p_I \vartheta_{i_1} \otimes \dots \otimes \vartheta_{i_r} \right) \circ \left(\sum_{12 \dots n \in u_1 \mathbf{1} \dots \mathbf{1} u_r} u_1 \otimes \dots \otimes u_r \right) \\
&= \sum_{\substack{I=(i_1, \dots, i_r), \lambda(I)=\lambda \\ 12 \dots n \in u_1 \mathbf{1} \dots \mathbf{1} u_r, |u_k|=i_k}} p_I (\vartheta_{i_1} \cdot u_1) \dots (\vartheta_{i_r} \cdot u_r)
\end{aligned}$$

where $\vartheta_i = \alpha(\Psi_i)$ is Dynkin's element and where c is for the usual coproduct on $K\langle A \rangle$. Observe that if $u_1 \otimes \dots \otimes u_r$ is in the support of $c(12 \dots n)$, then $u_{\sigma(1)} \otimes \dots \otimes u_{\sigma(r)}$ also belongs to the support of this coproduct. Taking now a set S of representatives of the orbits of r -uples (u_1, \dots, u_r) of words under the action of \mathfrak{S}_r , we obtain

$$\alpha(E) = \sum_{\substack{\sigma \in \mathfrak{S}_r \\ (u_1, \dots, u_r) \in S}} p_{\lambda \cdot \sigma} (\vartheta_{l_{\sigma(1)}} \cdot u_{\sigma(1)}) \dots (\vartheta_{l_{\sigma(r)}} \cdot u_{\sigma(r)}) .$$

This shows that $\alpha(E) \in M$ from which it follows that $Im E \subset M$, as desired.

On the other hand, a simple manipulation of the definition of the convolution product shows that

$$\alpha(E) \cdot (\vartheta_{l_1} \dots \vartheta_{l_r}) = \frac{1}{m_1! \dots m_n!} \left(\sum_{\sigma \in \mathfrak{S}_r} p_{\lambda \cdot \sigma} \vartheta_{l_{\sigma(1)}} \dots \vartheta_{l_{\sigma(r)}} \right)$$

if $\lambda = (1^{m_1}, \dots, n^{m_n})$, which implies that $M \subset Im E$. \square

The following corollary is essentially a reformulation of Proposition 7.4.

Corollary 7.6 *Let, for all $n \geq 1$, π_n be a Lie idempotent of degree n and set $\pi = (\pi_n)_{n \geq 1}$. For every partition $\lambda = (\lambda_1, \dots, \lambda_r)$, there exists then a probability distribution p_λ on \mathfrak{S}_r with the following properties :*

- $p_\lambda(\sigma) = p_\lambda(\tau)$ whenever the compositions $\lambda \cdot \sigma$ and $\lambda \cdot \tau$ are equal. This common value will be denoted by $p_\lambda(\sigma \cdot \lambda)$ in the sequel.
- The image of the projector $E_\lambda(\pi)$ is the module generated by all p_λ -symmetrized products

$$(P_1, \dots, P_r)_{p_\lambda} = \sum_{\sigma \in \mathfrak{S}_r} p_\lambda(\sigma \cdot \lambda) P_{\sigma(1)} \dots P_{\sigma(r)}$$

where each P_i is a homogeneous Lie polynomial of degree λ_i .

Example 7.7 The family $\Phi = (\Phi_n)_{n \geq 1}$ of Solomon idempotents is characterized by the fact that the associated probability distributions are uniform.

As another simple consequence of Proposition 7.4, we can also give the structure of the multihomogeneous modules associated with Dynkin idempotents.

Corollary 7.8 *Let $\lambda = (\lambda_1, \dots, \lambda_r)$ be a partition of n . The image of the projector $E_\lambda(\Psi_n)$ is the module spanned by the elements*

$$(P_{\lambda_1}, \dots, P_{\lambda_r})_\Psi = \sum_{\sigma \in \mathfrak{S}_r} \frac{\lambda_1 \dots \lambda_r}{\lambda_{\sigma(1)} (\lambda_{\sigma(1)} + \lambda_{\sigma(2)}) \dots (\lambda_{\sigma(1)} + \dots + \lambda_{\sigma(r)})} P_{\lambda_{\sigma(1)}} \dots P_{\lambda_{\sigma(r)}} .$$

where P_{λ_i} is a homogeneous Lie polynomial of degree λ_i .

Corollary 7.9 Let $(\pi_n)_{n \geq 1}$ be a family of Lie idempotents and let $I = (i_1^{n_1}, \dots, i_r^{n_r})$ be any composition of n (with $i_k \neq i_{k+1}$ for all k). The element π^I is then, up to a constant factor, an idempotent whose image under α is a projector onto the module

$$\underbrace{(L(A)_{i_1}, \dots, L(A)_{i_1})}_{n_1 \text{ terms}} \underbrace{(L(A)_{i_2}, \dots, L(A)_{i_2})}_{n_2 \text{ terms}} \dots \underbrace{(L(A)_{i_r}, \dots, L(A)_{i_r})}_{n_r \text{ terms}},$$

generated by the products $(P_1^{(1)}, \dots, P_1^{(n_1)}) \dots (P_r^{(1)}, \dots, P_r^{(n_r)})$ where $P_k^{(l)}$ is a homogeneous Lie polynomial of degree i_k for $k \in [1, r]$ and where $(\bullet, \dots, \bullet)$ denote the usual symmetrized product in $K\langle A \rangle$.

Proof — The only thing to check is the fact that π^I is actually quasi-idempotent. This follows from Proposition 2.1 and a simple computation. \square

7.3 Structure of the modules associated with deformations of some classical Lie idempotents

We describe here without proof the structure of the multihomogeneous modules associated with the deformations of Φ_n and Ψ_n defined by the transformations of alphabets $A \rightarrow (1-q)A$ and $A \rightarrow A/(1-q)$. All these results can be proved by variants of the arguments of the preceding subsection.

7.3.1 $\Phi_n((1-q)A)$

We need first to introduce a q -analogue of the factorial, connected with the combinatorics of descents and compositions.

Let $r \geq 1$ be an integer and let S be a subset of $[1, r]$. We associate with S the vector $v(S) = (v(S)_1, \dots, v(S)_r) \in \{0, 1\}^r$ where $v(S)_i = 1$ iff $i \in S$. We can then consider a new vector $s(S) = (s(S)_1, \dots, s(S)_r) \in \mathbb{N}^r$ defined by

$$s(S)_i = v(S)_i + \dots + v(S)_r$$

for $i \in [1, r]$.

Example 7.10 The following table gives the values of the above vectors and numbers for all subsets of $[1, 1]$, $[1, 2]$ and $[1, 3]$.

2	\emptyset	(0)	(0)	1
11	\emptyset	(1)	(1)	1
3	\emptyset	(0, 0)	(0, 0)	1
21	{2}	(0, 1)	(1, 1)	2
12	{1}	(1, 0)	(1, 0)	2
111	{1, 2}	(1, 1)	(2, 1)	1
4	\emptyset	(0, 0, 0)	(0, 0, 0)	1
31	{3}	(0, 0, 1)	(1, 0, 0)	3
22	{2}	(0, 1, 0)	(1, 1, 0)	5
211	{2, 3}	(0, 1, 1)	(2, 2, 1)	3
13	{1}	(1, 0, 0)	(1, 0, 0)	3
121	{1, 3}	(1, 0, 1)	(2, 1, 1)	5
112	{1, 2}	(1, 1, 0)	(2, 1, 0)	3
1111	{1, 2, 3}	(1, 1, 1)	(3, 2, 1)	1

□

Let now $I = (i_1, \dots, i_r)$ be a composition of length r . We associate with I the q -analogue of $(r + 1)!$ defined by

$$[(r + 1)!]_{I,q} = \sum_{S \subset [1,r]} d_S q^{s(S) i_1 + \dots + s(S) i_r}, \quad (56)$$

where $d_S = |\{\sigma \in \mathfrak{S}_{r+1}, D(\sigma) = S\}|$ denotes the number of permutations of \mathfrak{S}_{r+1} whose descent set is equal to S .

Example 7.11 For $r = 1$, $r = 2$ and $r = 3$, one can read on the table the following formulas:

$$[2!]_{(i_1),q} = 1 + q^{i_1},$$

$$[3!]_{(i_1, i_2),q} = 1 + 2q^{i_1+i_2} + 2q^{i_1} + q^{2i_1+i_2},$$

$$[4!]_{(i_1, i_2, i_3),q} = 1 + 3q^{i_1+i_2+i_3} + 5q^{i_1+i_2} + 3q^{2i_1+2i_2+i_3} + 3q^{i_1} + 5q^{2i_1+i_2+i_3} + 3q^{2i_1+i_2} + q^{3i_1+2i_2+i_3}.$$

□

For a composition $I = (i_1, \dots, i_r)$ of length r , set

$$a_I(q) = \frac{[r!]_{(i_1, \dots, i_{r-1}),q}}{r!} \frac{[i_1]_q [i_2]_q \dots [i_r]_q}{[i_1]_q [i_1 + i_2]_q \dots [i_1 + \dots + i_r]_q}. \quad (57)$$

Let now $\lambda = (\lambda_1, \dots, \lambda_r)$ be a partition of n . We can now define a q -deformation of the usual symmetrized product by

$$(x_{\lambda_1}, \dots, x_{\lambda_r})_{\Phi((1-q)A)} = \sum_{\sigma \in \mathfrak{S}_r} a_{\sigma, \lambda}(q) x_{\lambda_{\sigma(1)}} \dots x_{\lambda_{\sigma(r)}}. \quad (58)$$

This product clearly reduces to the ordinary symmetrized product for $q = 0$. Also, the family $a = (a_{\sigma, \lambda}(q))_{\sigma \in \mathfrak{S}_r}$ is a probability distribution over \mathfrak{S}_r , as we will see in the sequel. The following result provides therefore a complete description, of the multihomogeneous modules associated with the Lie idempotents $\Phi_n((1 - q)A)/(n(1 - q^n))$.

jector $E_\lambda(\Phi_n((1-q)A)/(1-q^n))$ is the module generated by all products of the form

$$(P_{\lambda_1}, \dots, P_{\lambda_r})_{\Phi((1-q)A)}$$

where P_{λ_i} is an arbitrary homogeneous Lie polynomial of order λ_i .

Note that the case $q = 1$ gives again Corollary 7.8.

7.3.2 $\Phi_n(A/(1-q))$

For a composition $I = (i_1, \dots, i_r)$, define now

$$B_I(q) = \sum_{k=1}^r \binom{r-1}{k-1} (-1)^{k-1} q^{i_1+\dots+i_{k-1}} [i_k]_q,$$

and set

$$b_I(q) = \frac{B_I(q)}{(1-q)^{r-1} r! [i_1]_q \dots [i_r]_q}.$$

The relevant q -deformation of the symmetrized product is defined by

$$(x_{\lambda_1}, \dots, x_{\lambda_r})_{\Phi(A/(1-q))} = \sum_{\sigma \in \mathfrak{S}_r} b_{\sigma \cdot \lambda} x_{\lambda_{\sigma(1)}} \dots x_{\lambda_{\sigma(r)}}.$$

Indeed, we have:

Proposition 7.13 *Let $\lambda = (\lambda_1, \dots, \lambda_r)$ be a partition of n . Then the image of the projector $E_\lambda(\Phi_n(A/(1-q))/(1-q^n))$ is the module generated by the products*

$$(P_{\lambda_1}, \dots, P_{\lambda_r})_{\Phi(A/(1-q))}$$

where P_{λ_i} is an arbitrary homogeneous Lie polynomial of degree λ_i .

7.3.3 $\Psi_n((1-q)A)$

Let $I = (i_1, \dots, i_r, i_{r+1})$ be a composition of length $r+1$. We associate with it the family $(\gamma_{S,I})_{S \subset [1,r]}$ of \mathbb{N}^{2^r} defined by $\gamma_{\emptyset, (i_1)} = 1$ for every $i_1 \geq 1$ (when $r = 0$) and by the inductive rules

$$\forall S \subset [1, r-1], \begin{cases} \gamma_{S \cup \{r\}, I} = \binom{i_{r-1} + i_r - 1}{i_r} \gamma_{S, (i_1, \dots, i_{r-2}, i_{r-1} + i_r)}, \\ \gamma_{S, I} = \binom{i_1 + \dots + i_r}{i_r} \gamma_{S, (i_1, \dots, i_{r-1})} - \binom{i_{r-1} + i_r - 1}{i_r} \gamma_{S, (i_1, \dots, i_{r-2}, i_{r-1} + i_r)} \end{cases}$$

(when $r \geq 1$). Next, we introduce the polynomial $C_I(q) \in \mathbb{N}[q]$ defined by

$$C_I(q) = \sum_{S \subset [1,r]} \gamma_{S,I} q^{s(S)_1 i_1 + \dots + s(S)_r i_r}.$$

Example 7.14 Let us show how to compute $C_{(2,3,1)}(q)$. We need first to compute

$$\gamma_{\{1\}, (2,3)} = \binom{4}{3} = 4, \quad \gamma_{\emptyset, (2,3)} = \binom{5}{3} - \binom{4}{3} = 10 - 4 = 6,$$

It follows that

$$\gamma_{\{1,2\},(2,3,1)} = \binom{3}{1} \gamma_{\{1\},(2,4)} = 3 \times 5 = 15, \quad \gamma_{\{2\},(2,3,1)} = \binom{3}{1} \gamma_{\emptyset,(2,4)} = 3 \times 10 = 30,$$

$$\gamma_{\{1\},(2,3,1)} = \binom{6}{1} \gamma_{\{1\},(2,3)} - \gamma_{\{1,2\},(2,3,1)} = 6 \times 4 - 15 = 9,$$

$$\gamma_{\emptyset,(2,3,1)} = \binom{6}{1} \gamma_{\emptyset,(2,3)} - \gamma_{\{2\},(2,3,1)} = 6 \times 6 - 30 = 6.$$

Hence we finally get

$$\begin{aligned} C_{(2,3,1)}(q) &= 15 q^{2 \times 2 + 1 \times 3} + 30 q^{1 \times 2 + 1 \times 3} + 9 q^{1 \times 2 + 0 \times 3} + 6 q^{0 \times 2 + 0 \times 3} \\ &= 15 q^7 + 30 q^5 + 9 q^2 + 6. \end{aligned}$$

For a composition $I = (i_1, \dots, i_r)$ of length r , let us set

$$c_I(q) = \frac{[i_1]_q \cdots [i_r]_q}{[i_1]_q [i_1 + i_2]_q \cdots [i_1 + \dots + i_r]_q} \frac{C_I(q)}{\binom{i_1 + \dots + i_r}{i_1, \dots, i_r}}.$$

Let $\lambda = (\lambda_1, \dots, \lambda_r)$ be a partition of n . The q -symmetrized product will be in this case

$$(x_1, \dots, x_n)_{\Psi((1-q)A)} = \sum_{\sigma \in \mathfrak{S}_r} c_{\sigma \cdot \lambda}(q) x_{\lambda_{\sigma(1)}} \cdots x_{\lambda_{\sigma(r)}},$$

and we have:

Proposition 7.15 *Let $\lambda = (\lambda_1, \dots, \lambda_r)$ be a partition of n . Then the image of the projector $E_\lambda(\Psi_n(A/(1-q))/(1-q^n))$ is the module generated by all products of the form*

$$(P_{\lambda_1}, \dots, P_{\lambda_r})_{\Psi((1-q)A)}$$

where P_{λ_i} is an arbitrary homogeneous Lie polynomial of degree λ_i .

7.3.4 $\Psi_n(A/(1-q))$

For $I = (i_1, \dots, i_r)$, define the polynomial $D_I(q)$ by the recurrence relations

$$\begin{cases} D_{i_1} &= [i_1]_q \\ D_I(q) &= \sum_{k=1}^r D_{i_1, \dots, i_{k-1}, i_k-1, i_{k+1}, \dots, i_r}(q) + \binom{|I|-1}{i_1-1} q^{i_1-1} D_{i_2, \dots, i_r}(q) \quad \text{for } l(I) \geq 2 \end{cases}$$

with the convention that $D_{\dots, 0, \dots}(q) = 0$. We set

$$d_I(q) = \frac{D_I(q)}{\binom{|I|}{i_1, \dots, i_r} [i_1]_q \cdots [i_r]_q}.$$

The q -analogue of the symmetrized product will be defined by

$$(x_{\lambda_1}, \dots, x_{\lambda_r})_{\Psi(A/(1-q))} = \sum_{\sigma \in \mathfrak{S}_r} d_{\sigma \cdot \lambda} x_{\lambda_{\sigma(1)}} \cdots x_{\lambda_{\sigma(r)}}.$$

Proposition 7.16 *Let $\lambda = (\lambda_1, \dots, \lambda_r)$ be a partition of n . Then the image of the projector $E_\lambda(\Psi_n(A/(1-q))/(1-q^n))$ is the module generated by all products of the form*

$$(P_{\lambda_1}, \dots, P_{\lambda_r})_{\Psi(A/(1-q))}$$

where P_{λ_i} is an arbitrary homogeneous Lie polynomial of degree λ_i .

- [1] E. ABE , *Hopf algebras*, Cambridge University Press, 1977.
- [2] J. BERSTEL and C. REUTENAUER, *Rational series and their languages*, EATCS Monographs on Theoretical Computer Science, Springer, Berlin, 1988.
- [3] R.W. CARTER, *Representation theory of the 0-Hecke algebra*, J. Algebra, **15** (1985), 89–103.
- [4] G. DUCHAMP, *Orthogonal projection onto the free Lie algebra*, Theor. Comput. Sci., **79** (1991), 227–239.
- [5] G. DUCHAMP, D. KROB, A. LASCoux, B. LECLERC, T. SCHARF and J.-Y. THIBON, *Euler-Poincaré characteristic and polynomial representations of Iwahori-Hecke algebras*, Publications of the R.I.M.S., Kyoto University, **31** (1995), 179–201.
- [6] G. DUCHAMP, D. KROB, B. LECLERC and J.-Y. THIBON, *Déformations de projecteurs de Lie*, C.R. Acad. Sci. Paris **319** (1994), 909-914.
- [7] G. DUCHAMP, D. KROB, B. LECLERC and J.-Y. THIBON, *Fonctions quasi-symétriques, fonctions symétriques non-commutatives, et algèbres de Hecke à $q = 0$* , C.R. Acad. Sci. Paris (to appear).
- [8] D.I FIVEL, *Interpolation between Bose and Fermi statistics using generalized commutators*, Physical Review Letters, **65** (1990), 3361-3364.
- [9] A. GARSIA and C. REUTENAUER, *A decomposition of Solomon's descent algebra*, Adv. in Math. **77** (1989), 189–262.
- [10] I.M. GELFAND, D. KROB, A. LASCoux, B. LECLERC B, V.S. RETAKH and J.-Y. THIBON, *Noncommutative symmetric functions*, Adv. in Math. **112** (1995), 218–348.
- [11] I.M. GELFAND and V.S. RETAKH, *Determinants of matrices over noncommutative rings*, Funct. Anal. Appl. **25** (1991), 91-102.
- [12] I.M. GELFAND and V.S. RETAKH, *A theory of noncommutative determinants and characteristic functions of graphs*, Funct. Anal. Appl. **26** (1992), 1-20.
- [13] M. GERSTENHABER and D. SCHACK, *A Hodge-type decomposition for commutative algebra cohomology*, J. Pure Appl. Alg. **48** (1987), 229-247.
- [14] I. GESSEL , *Multipartite P-partitions and inner product of skew Schur functions*, Contemp. Math. **34** (1984), 289–301.
- [15] O.W. GREENBERG, *Particles with small violations of Fermi or Bose statistics*, Physical Rev. D **43** (1991), 4111-4120.
- [16] V.G. KAC and D.A. KAZHDAN, *Structure of representations with highest weight of infinite dimensional Lie algebras*, Adv. in Math. **34** (1979), 97–108.
- [17] V.G. KAC, *Infinite dimensional Lie algebras*, Cambridge, 1990.
- [18] M. KASHIWARA, T. MIWA and E. STERN, *Decomposition of q-deformed Fock spaces*, preprint, 1995.
- [19] M. KAWSKI, *Chronological algebras and non-linear control*, Asian Control Conference, Tokyo, 1994.
- [20] D. KROB, B. LECLERC and J.-Y. THIBON, *Noncommutative symmetric functions II : Transformations of alphabets*, LITP preprint 95/07, Paris, 1995.
- [21] B. LECLERC, T. SCHARF and J.-Y. THIBON, *Noncommutative cyclic characters of symmetric groups*, J. Comb. Theory A, to appear.
- [22] J. L. LODAY, *Opérations sur l'homologie cyclique des algèbres commutatives*, Invent. Math. **96** (1989), 205-230.
- [23] I.G. MACDONALD, *Symmetric functions and Hall polynomials*, Oxford, 1979; 2nd ed. 1995.
- [24] C. MALVENUTO and C. REUTENAUER, *Duality between quasi-symmetric functions and the Solomon descent algebra*, Preprint UQAM, Montréal, 1993.

- [26] W. NICHOLS, *Bialgebras of type I*, Commun. Alg. **19** (1991), 3061–3073.
- [27] P.N. NORTON, *0-Hecke algebras*, J. Austral. Math. Soc. (Series A) **27** (1979), 337-357.
- [28] R. REE, *Generalized Lie elements*, Canad. J. Math. **12** (1960), 493–502.
- [29] G. RENAULT, *Algèbre non commutative*, Gauthiers-Villars, 1975.
- [30] C. REUTENAUER, *Free Lie algebras*, Oxford, 1994.
- [31] M. ROSSO, *Groupes quantiques et algèbres de battage quantiques*, C.R. Acad. Sci. Paris Ser. I **320** (1995), 145–148.
- [32] M.P. SCHÜTZENBERGER, *Sur une propriété combinatoire des algèbres de Lie libres pouvant être utilisée dans un problème de mathématiques appliquées*, Sémin. P. Dubreil, Faculté des Sciences, Paris, 1958.
- [33] N.N. SHAPOVALOV, *On a bilinear form on the universal enveloping algebra of a complex semisimple Lie algebra*, Funct. Anal. Appl. **6** (1972), 65–70.
- [34] V. SCHECHTMAN and A. VARCHENKO, *Quantum groups and homology of local systems*, in “Algebraic geometry and anal. geometry”, ICM-90 Satellite Conference, 182–191, Springer, 1991.
- [35] V. SCHECHTMAN and A. VARCHENKO, *Arrangements of hyperplanes and Lie algebra homology*, Invent. Math. **106** (1991), 139–194.
- [36] L. SOLOMON, *A Mackey formula in the group ring of a Coxeter group*, J. Algebra **41** (1976), 255–268.
- [37] E. STERN, *Semi-infinite wedges and vertex operators*, Internat. Math. Res. Notices **4** (1995), 210-220.
- [38] A. VARCHENKO, *Bilinear form of real configuration of hyperplanes*, Adv. in Maths. **97** (1993), 110–144.
- [39] S.L. WORONOWICZ, *Differential calculus on compact matrix pseudogroups (Quantum groups)*, Commun. Math. Phys. **122** (1989), 125–170.
- [40] D. ZAGIER, *Realizability of a model in infinite statistics*, Commun. Math. Phys. **147** (1992), 199–210.