



HAL
open science

symmetry discrimination and measurements of parity violating and magnetoelectric dichroisms in a Cs vapor

Jocelyne Guéna, Michel Lintz, Marie-Anne Bouchiat

► To cite this version:

Jocelyne Guéna, Michel Lintz, Marie-Anne Bouchiat. symmetry discrimination and measurements of parity violating and magnetoelectric dichroisms in a Cs vapor. 8th EPS conference on atomic and molecular physics, 2004, Rennes, France. pp.1-3. hal-00002628

HAL Id: hal-00002628

<https://hal.science/hal-00002628v1>

Submitted on 20 Aug 2004

HAL is a multi-disciplinary open access archive for the deposit and dissemination of scientific research documents, whether they are published or not. The documents may come from teaching and research institutions in France or abroad, or from public or private research centers.

L'archive ouverte pluridisciplinaire **HAL**, est destinée au dépôt et à la diffusion de documents scientifiques de niveau recherche, publiés ou non, émanant des établissements d'enseignement et de recherche français ou étrangers, des laboratoires publics ou privés.

SYMMETRY DISCRIMINATION AND MEASUREMENTS OF PARITY VIOLATING AND MAGNETOELECTRIC DICHROISMS IN A Cs VAPOUR

J. Guéna, M. Lintz and M.-A. Bouchiat,

Département de Physique de l'ENS 24 rue Lhomond, 75 231 Paris cedex 05, FRANCE

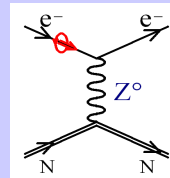

Particle physics...
...at low energies!

PRINCIPLE OF THE EXPERIMENT

EXCITATION AND DETECTION

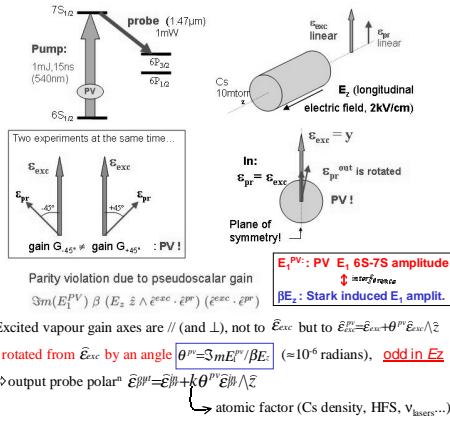

POLARIMETRIC METHOD OF MEASUREMENT ...and CALIBRATION

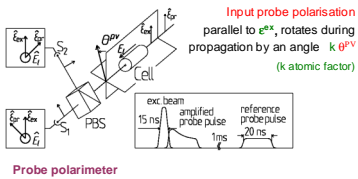

Selection criteria of the PV rotational invariant

Criteria	Selection of	against	Period
$D = \frac{S_x - S_y}{S_x + S_y}$	Imbalance between R-L configurations	intensity, population	each pulse
$\Delta D = D^{amp} - D^{ref}$	Atomic imbalance	non atomic	1 ms
$\pm \theta^{cal}$	imbalance D^{cal}	CALIBRATION	0.4s
E_z -odd	PV effect (main signature)	most PC E_z effects (Stark-Stark)	0.8s
Tilt (θ^{out} -odd)	True polarization effect	instrumental defects (EMI, geometrical)	6s
θ^{PV} [$\begin{matrix} \parallel E^{exc} \\ \perp E^{exc} \end{matrix} $ -even]	Linear dichroism (Atomic alignment)	optical rotation (e.g. Faraday)	12s
θ^{exc} -isotropic	Rotational invariant (cf "cylindrical symmetry")	stray transverse B_z, E_z field effects	2 mn

1 PV data

IMPLEMENTATION of the EXPERIMENT

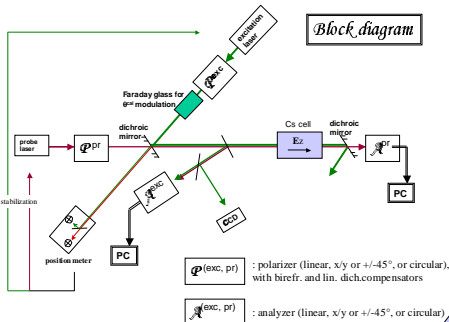

PRESENT RESULTS

EVOLUTION OF THE RESULTS (6 different cells)

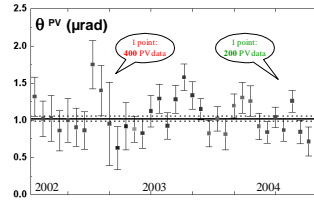

Since first results (PRL, 2003), S/N improved by 3.3
=> acquisition time for S/N=1 reduced by 10

Current average result (at 1.74kV/cm): $\theta^{PV} = 1.019 \pm 0.034$ (μrad)
agrees with Boulder's more precise result

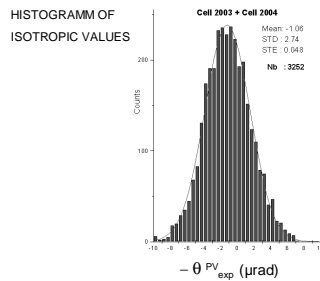

CYLINDRICAL SYMMETRY DISCRIMINATION AND THE MAGNETO-ELECTRIC EFFECTS

The experiment is invariant under rotations of ($\hat{E}_{exc}, \hat{E}_{pr}$) around $\hat{k} // \hat{E}$

4 Polarization config^{ns}: 0°, 45°, 90°, 135°



But is the isotropic part free from systematics arising from E_z , B_z fields or misalignments?

The case of transverse E and B fields:

Ideal situation: pure longitudinal E field (and probe polarization $\hat{E}_{pr} // \hat{E}_{exc}$)
-> (Stark) Parity-conserving alignment with axes \hat{E}_{exc} and $\hat{E}_{exc} // \hat{E}_{exc}$

-> no imbalance in output probe polarimeter

+ transverse E field

- > adds new Stark alignment, with revolution symmetry around \hat{z}
- > yet, no imbalance

+ transverse B field

- > Larmor precession of the E_z -induced alignment
- > this new rotated alignment is detectable by the probe
- > non-zero polarimeter imbalance:

θ^{PV} measured and reduced in dedicated sequences -> $\theta_{sys} \leq \theta^{PV} / 10$, corrected

This is a P-conserving "Jones Dichroism" (i.e. with axes at 45° from \hat{z}) due to the transverse E_z and B_z fields

Magneto-electric optical effects have also been observed in liquids, yet with a $B_z = 15T$ and $E_z = 1.7kV/cm$

Here it is easily observed with $B_z = 1G$, $E_z = 10V/cm$ in a dilute vapor, and fully understood

The case of a transverse E field and a pump-probe misalignment

a probe misalignment α is equivalent to a rotation of angle/direction of the probe with respect to the exc beam
-> is given by the above formula except for the replacement

$$E_z \rightarrow E_z \cos \alpha$$

HOW TO AMPLIFY THE PV EFFECTS?

PASSIVE AMPLIFICATION

Polarization Magnifier at cell output :

Passive Amplification of the Polarization Tilt

dichroic component with axes x (transmission = 1) and y (transmission $T_y < 1$)

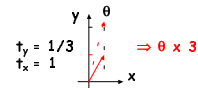

But... 9 x less photons detected :

photon shot noise also increased X 3 !

To gain in S/N we increase the probe intensity

How to make a polarisation magnifier ?

6 brewster plates... with no two surfaces parallel ! (interference + linear birefringence -> birefringence)

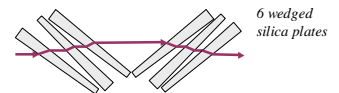

ACTIVE AMPLIFICATION

...by the atomic medium itself!

Excited vapour = anisotropic amplifier (η : gain anisotropy)

-> exponential growth of both

probe intensity and left-right asymmetry vs. optical density

$$A_{LR} \equiv 2 \theta^{PV} x [\exp(\eta A) - 1]$$

$$= 2 (E_z^{PV} / \beta E_z) x [\exp(\eta A) - 1]$$

where $A = \ln(I^{out} / I^{in})$: optical density, $\propto E_z^2$

-> Increase E_z at will? ...But cell is long (8cm)

-> high endcap potentials -> discharges at $E_z > 1.8kV/cm$

Exploiting further A_{LR} amplification: a new PV proposal in transverse E field

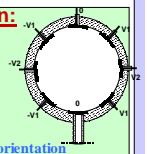

-> observable = PV excited-state orientation

The PV orientation is transverse

- > apply transverse B field -> longitudinal PV orientation
- > probe circ. dichroism, detected using circular analyser

Advantages of the transverse field configuration:

- Larger excitation rate (involves scalar polarisability $\alpha \approx 10\beta$),
- Longer interaction length is possible without discharges.

Cylindrical symmetry restored by rotating E and B fields by 45° steps
-> predicted quantum-noise limit improves by a factor 10, or even more in the triggered superradiant regime!

REFERENCES

- "A new manifestation of atomic parity violation in cesium: a chiral optical gain induced by linearly polarized 6S-7S excitation"
J. Guéna, D. Chauvet, Ph. Jacquier, E. Jabier, M. Lintz, S. Sanguinetti, A. Wasan, A. V. Papoyan, D. Sarkisyan, Phys. Rev. Lett. 98, 143001 (2003)
- "Cylindrical symmetry discrimination of magneto-electric optical systematic effects in a pump-probe atomic parity violation experiment"
M.-A. Bouchiat, J. Guéna, M. Lintz: Eur. Phys. J. D28, 331 (2004)
- "Prospects for forbidden-transition spectroscopy and parity violation measurements using a beam of cold stable or radioactive atoms"
S. Sanguinetti, J. Guéna, M. Lintz, Ph. Jacquier, A. Wasan, M.-A. Bouchiat: Eur. Phys. J. D25, 3 (2003)
- Proposal for high precision parity violation measurements using amplification of the asymmetry by stimulated emission in a transverse E and B fields pump-probe experiment
J. Guéna, M. Lintz, M.-A. Bouchiat, to be published in JOSA B (arXiv:physics/0403141)