



HAL
open science

Continuous variable entanglement using cold atoms

Vincent Josse, Aurelien Dantan, Alberto Bramati, Michel Pinard, Elisabeth Giacobino

► **To cite this version:**

Vincent Josse, Aurelien Dantan, Alberto Bramati, Michel Pinard, Elisabeth Giacobino. Continuous variable entanglement using cold atoms. 2003. hal-00000437v2

HAL Id: hal-00000437

<https://hal.science/hal-00000437v2>

Preprint submitted on 12 Sep 2003 (v2), last revised 1 Dec 2003 (v3)

HAL is a multi-disciplinary open access archive for the deposit and dissemination of scientific research documents, whether they are published or not. The documents may come from teaching and research institutions in France or abroad, or from public or private research centers.

L'archive ouverte pluridisciplinaire **HAL**, est destinée au dépôt et à la diffusion de documents scientifiques de niveau recherche, publiés ou non, émanant des établissements d'enseignement et de recherche français ou étrangers, des laboratoires publics ou privés.

Continuous variable entanglement using cold atoms

V. Josse, A. Dantan, A. Bramati, M. Pinard, and E. Giacobino

Laboratoire Kastler Brossel, Université Pierre et Marie Curie, Ecole Normale Supérieure et CNRS,
Case 74, 4 place Jussieu, 75252 Paris Cedex 05, France

(Dated: September 12, 2003)

We present an experimental demonstration of both *quadrature* and *polarization entanglement* generated via the interaction between a coherent linearly polarized field and cold atoms in a high finesse optical cavity. The non linear atom-field interaction produces two squeezed modes with orthogonal polarizations which are used to generate a pair of non separable beams, the entanglement of which is demonstrated by checking the inseparability criterion for continuous variables recently derived by Duan *et al.* [Phys. Rev. Lett. **84**, 2722 (2000)].

PACS numbers: 42.50.Dv, 42.50.Ct, 03.67.Hk

Entanglement in the continuous variable regime has attracted a lot of attention in the quantum optics and quantum information fields in connection with quantum teleportation, cryptography, quantum computing and dense coding [1]. Since the first realization of quadrature entangled beams by Ou *et al.* [2], various methods, such as $\chi^{(2)}$ process in optical parametric amplifier (OPA) [3], or Kerr effect in optical fibers [4], have been used to generate non separable beams. Recently, the concept of *polarization entanglement*, i.e. entanglement of Stokes operators between two beams, has been investigated by Korolkova *et al.* [5], and first demonstrated experimentally by Bowen *et al.* [6] by mixing two squeezed beams issued from independent OPAs. The Kerr non-linearity of fibers was also exploited by Glöckl *et al.* to generate a pulsed source of polarization entanglement [7].

In this paper we show evidence for continuous variable entanglement generated using the interaction between a linearly polarized coherent field and a cloud of cold cesium atoms placed in a high finesse optical cavity. We quantify the entanglement with the inseparability criterion proposed by Duan *et al.* and Simon [8]. We demonstrate the generation of two kinds of entanglement with the same system, quadrature entanglement and polarization entanglement. For this, we use the recently reported generation of polarization squeezing [9] in the field that has interacted with cold atoms; both the mean field mode and the vacuum mode with orthogonal polarization exiting the cavity can be squeezed. First, we show how a direct measurement of the quadrature entanglement of the beam exiting the cavity can be achieved using two balanced homodyne detections. Then, we produce two non separable beams by mixing two parts of the previous outgoing beam with a strong field and achieve polarization entanglement by locking the relative phases between the strong field and the weak field exiting the cavity.

First, let us consider two orthogonally polarized modes A_a and A_b of the electromagnetic field satisfying the usual bosonic commutation rules $[A_\alpha, A_\beta^\dagger] = \delta_{\alpha\beta}$. If $X_\alpha(\theta) = (A_\alpha^\dagger e^{i\theta} + A_\alpha e^{-i\theta})$ and $Y_\alpha(\theta) = X_\alpha(\theta + \pi/2)$ are the usual quadrature operators (rotated in the Fresnel

diagram by angle θ), $X_a + X_b$ and $Y_a - Y_b$ are the continuous variable analogous of the EPR-type operators first introduced by Einstein, Podolsky and Rosen [10]. The criterion of [8] sets a limit for inseparability on the sum of the operator variances

$$\mathcal{I}_{a,b}(\theta) = \frac{1}{2} [\Delta^2(X_a + X_b)(\theta) + \Delta^2(Y_a - Y_b)(\theta)] < 2 \quad (1)$$

For states with Gaussian statistics, $\mathcal{I}_{a,b} < 2$ is a sufficient condition for entanglement and has already been used to quantify continuous variable entanglement [5, 6, 7].

In our system, an x -polarized beam interacts with a cloud of cold cesium atoms in an optical cavity. The experimental set-up [9] is shown in Fig. 2. The cavity coupling mirror has a transmission coefficient of 10%, the rear mirror is highly reflecting. We probe the atoms with a linearly polarized laser beam detuned by about 50 MHz in the red of the $6S_{1/2}$, $F=4$ to $6P_{3/2}$, $F=5$ transition. The optical power of the probe beam ranges from 5 to 15 μ W. After exiting the cavity, both the mean field mode A_x and the orthogonally polarized vacuum mode A_y are squeezed for frequencies ranging between 3 and 12 MHz. An interpretation of these results can be provided by modelling the complicated $6S_{1/2}$, $F=4$ to $6P_{3/2}$, $F=5$ transition by an X-like four-level atomic structure represented in Fig. 1. When the two transitions are saturated, the atoms behave as a Kerr-like medium for A_\pm [11], both of which may be squeezed [12]. Because of the symmetry of the system, they are squeezed for the same quadrature. From the viewpoint of linear polarizations the x, y modes are also squeezed due to cross-Kerr effect, but for *orthogonal* quadratures [9, 12].

Our goal is to retrieve the two modes with orthogonal polarizations which are maximally entangled in the sense of the inseparability criterion (1). One has to minimize the quantity $\mathcal{I}_{a,b}(\theta)$ with respect to a, b and θ . Expanding (1) yields

$$\mathcal{I}_{a,b}(\theta) = \langle \delta A_a^\dagger \delta A_a + \delta A_a \delta A_a^\dagger + \delta A_b \delta A_b^\dagger + \delta A_b^\dagger \delta A_b \rangle$$

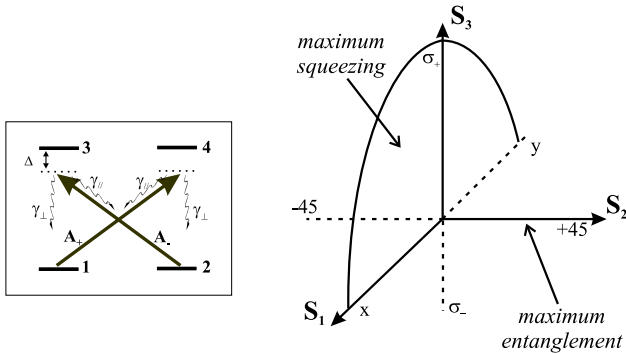

FIG. 1: *Left*: X-like atomic level structure. *Right*: Poincaré sphere for the Stokes parameters. While the sum of squeezing is maximal in the (S_1, S_3) plane, entanglement is optimal along the S_2 -axis.

$$+2[e^{-2i\theta}\langle\delta A_a\delta A_b\rangle + e^{2i\theta}\langle\delta A_a^\dagger\delta A_b^\dagger\rangle] \quad (2)$$

The right hand side of the first line in (2) is independent of the polarization basis, while the second line can be written as $4\cos(2\theta - 2\phi)|\langle\delta A_a\delta A_b\rangle|$, where 2ϕ is the phase angle of $\langle\delta A_a\delta A_b\rangle$. Minimizing $\mathcal{I}_{a,b}(\theta)$ corresponds to maximizing $|\langle\delta A_a\delta A_b\rangle|$ with respect to a, b . In order to find the optimal field components a, b , we introduce another polarization basis u, v , such that $\langle\delta A_u\delta A_v\rangle = 0$. It can be shown that there always exists such a polarization basis and that the u and v modes quadrature variances are minimal for the same value of θ [13]. The optimal entanglement produced in the system is directly related to the quantum noise properties of these modes u, v . Indeed, the maximally entangled modes a^*, b^* are

$$A_{a^*} = (A_u + iA_v)/\sqrt{2}, \quad A_{b^*} = (A_u - iA_v)/\sqrt{2} \quad (3)$$

and the minimum value of $\mathcal{I}_{a,b}$ is then given by the sum of the u, v modes minimal noises

$$\mathcal{I}_{a^*,b^*} = \min_{a,b,\theta} \mathcal{I}_{a,b}(\theta) = \min_{\theta} [\Delta^2 X_u(\theta) + \Delta^2 X_v(\theta)] \quad (4)$$

Consequently, if one or two of the u, v modes are squeezed the value \mathcal{I}_{a^*,b^*} of the optimal entanglement is equal to the sum of the best squeezings that can be obtained in the system. Experimentally, one has to look for the u, v -type modes, a signature of which being that $\mathcal{I}_{u,v}(\theta)$ does not depend on θ [see (2)], and measure their squeezing (if any). The maximally entangled modes are then given by (3) and their entanglement by (4).

Let us note that modes u, v are not *a stricto sensu* uncorrelated, since $\langle\delta A_u\delta A_v^\dagger\rangle$ can be non zero. However, one can think of the correlation properties of modes a^*, b^* as being created by the mixing of the u and v modes, as it is usually produced by mixing two independent squeezed beams [2, 4, 6]. Let us stress that this analysis provides a

general framework for optimizing the entanglement produced in a two-mode system exhibiting quantum properties. This method is of interest for a class of systems such as the optical parametric oscillator in which the correlations are not produced by mixing independent beams [14].

Coming back to our system, it is easy to see that $\langle\delta A_x\delta A_y\rangle = 0$ because they are combinations with equal weights of symmetrical modes A_\pm . Since they are squeezed for orthogonal quadratures, one can set $A_u = A_x$ and $A_v = iA_y$. Then, using (3), the maximally entangled modes are the $\pm 45^\circ$ modes to the x, y basis.

These results may be summarized using the classical Poincaré sphere representation [5]. This representation relies on the Stokes parameters which characterize the polarization state of a light beam

$$\begin{aligned} S_0 &= A_x^*A_x + A_y^*A_y & S_1 &= A_x^*A_x - A_y^*A_y \\ S_2 &= A_x^*A_y + A_y^*A_x & S_3 &= i(A_y^*A_x - A_x^*A_y) \end{aligned}$$

In the Poincaré sphere [see Fig. 1], A_x and iA_y are squeezed for the same quadrature and uncorrelated. The same is true for A_+ and A_- , which are uncorrelated (for frequencies higher than the inverse pumping time, that are the ones we consider, the two transitions represented in Fig.1 are independent) and squeezed for the same quadratures. This tells us that the sum of squeezing is maximal in the meridional plane of the uncorrelated modes, defined by S_1 and S_3 , while the optimal entanglement axis is that of the $\pm 45^\circ$ modes.

This gives us the relevant quantity, $\mathcal{I}_{+45,-45}(\theta)$, which is to be measured. Using $A_{\pm 45} = (A_x \pm A_y)/\sqrt{2}$, the inseparability criterion for the $\pm 45^\circ$ modes can be expressed directly in terms of the x, y modes variances with $X_u(\theta) = X_x(\theta)$ and $X_v(\theta) = Y_y(\theta)$

$$\mathcal{I}_{+45,-45}(\theta) = \Delta^2 X_x(\theta) + \Delta^2 Y_y(\theta) < 2 \quad (5)$$

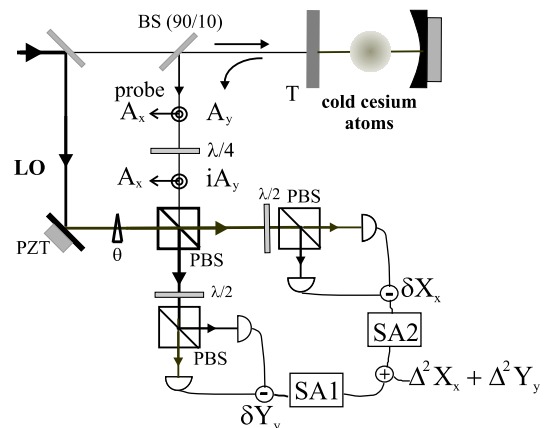

FIG. 2: Experimental set-up: PBS: polarizing beam splitter; $\lambda/2$: half-wave plate; PZT: piezo-electric ceramic.

When θ corresponds to the angle of the squeezed quadrature of A_x , both variances are below unity, and $\mathcal{I}_{+45,-45} < 2$.

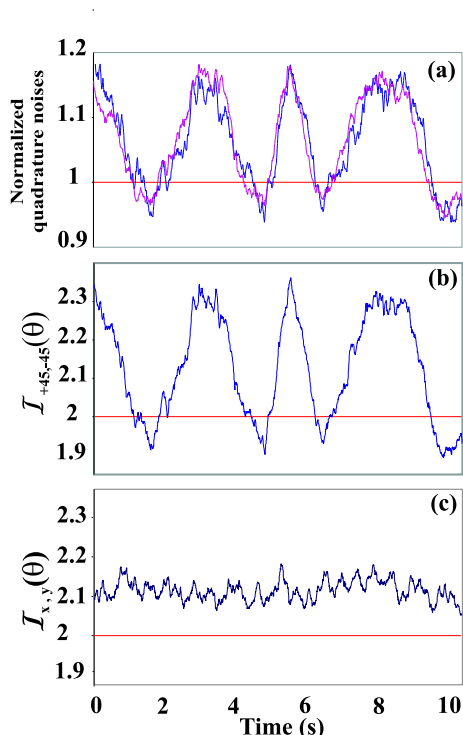

FIG. 3: (a) Quadrature noise spectra of A_x and iA_y , at a frequency of 5 MHz, when the relative phase θ between the LO and the mean field mode is varied in time. (b) Direct measurement of $\mathcal{I}_{+45,-45}(\theta)$. (c) Corresponding measurement of $\mathcal{I}_{x,y}(\theta)$.

In order to experimentally check for the inseparability criterion (5), we need to simultaneously measure the fluctuations of A_x and iA_y . After the output of the cavity, we insert a quarter-wave plate that dephases A_y by $\pi/2$, the beam is mixed on a beamsplitter with a local oscillator (LO), and the two resulting beams are sent into two balanced homodyne detections. Thus, we simultaneously measure the quadrature noise of each beam for the same quadrature. The sum of these two signals directly gives the sought quantity $\mathcal{I}_{+45,-45}(\theta)$. In Fig. 3(b), we plot a typical measurement of the entanglement as a function of θ , for an analysis frequency of 5 MHz. Its minimal value is about 1.9 and corresponds to a case for which A_x and iA_y are both squeezed by about 5% [Fig. 3(a)]. As expected, $\mathcal{I}_{x,y}$ is independent of θ , since these modes are uncorrelated [Fig. 3(c)]. *Quadrature entanglement* is thus achieved in a frequency range given by the cavity bandwidth (3 to 12 MHz). In good agreement with the theory, we find that the best entanglement is found around 5 MHz [9].

Then, we show that this quadrature entangled beam allows to generate *polarization entanglement*. Polarization entanglement for two beams α and β [5] is achieved

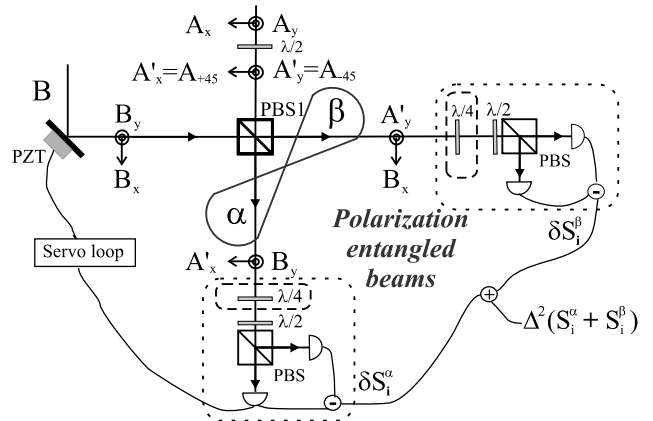

FIG. 4: Set-up for non separable beams generation. Inserting the quarter-wave plates (or not) allows for measuring the fluctuations of $S_3^\alpha + S_3^\beta$ (or $S_2^\alpha + S_2^\beta$). The servo loop is used to lock the B field phase to the squeezed quadrature angle.

when

$$\mathcal{I}_{\alpha,\beta}^S = \frac{1}{2}[\Delta^2(S_2^\alpha + S_2^\beta) + \Delta^2(S_3^\alpha + S_3^\beta)] < |\langle S_1^\alpha \rangle| + |\langle S_1^\beta \rangle|$$

For this, we produce new modes by mixing the $A_{\pm 45}$ modes studied previously with additional strong fields. The $A_{\pm 45}$ modes are obtained from the x, y modes by passing the beam through a half-wave plate with axes at $22,5^\circ$. The fields along the x and y directions are now the A_{+45} and A_{-45} fields, that we will denote by A'_x and A'_y [see Fig. 4]. The A'_x and A'_y are then spatially separated with a polarizing beamsplitter. In the other input of the beamsplitter, we send a strong field B with a polarization at 45° from the beamsplitter axes, yielding the output fields B_y and B_x . The strong field B is similar to the local oscillator in the previous experiment, except that its phase θ_B is locked to that of one of the A fields by a servo-loop, as shown in Fig. 4. At the two outputs of the beamsplitter, we have two beams α, β which are the superposition of, respectively, A'_x and B_y , and A'_y and B_x . The Stokes operators S_i^α for one of the outputs are then

$$\begin{aligned} S_0^\alpha &= A_x^\dagger A'_x + B_y^\dagger B_y & S_1^\alpha &= A_x^\dagger A'_x - B_y^\dagger B_y \\ S_2^\alpha &= A_x^\dagger B_y + B_y^\dagger A'_x & S_3^\alpha &= i(B_y^\dagger A'_x - A_x^\dagger B_y) \end{aligned}$$

The Stokes operators S_i^β for the other output are obtained by exchanging A' and B in the previous expression. Since the B field is much stronger than the A field, one has $|\alpha_B| \gg |\alpha_{A'}|$, with α_B the amplitude of B_x and B_y and $\alpha_{A'}$ the amplitude of A'_x and A'_y . Then $\langle S_1^\alpha \rangle = -\langle S_1^\beta \rangle \simeq -|\alpha_B|^2$ and the inseparability condition reads

$$\mathcal{I}_{\alpha,\beta}^S < 2|\alpha_B|^2 \quad (6)$$

In this case the Stokes parameters fluctuations are related to those of the initial $\pm 45^\circ$ modes (now denoted A'_x, A'_y) [9]

$$\begin{aligned}\delta S_2^\alpha &= \alpha_B \delta X'_x(\theta_B), & \delta S_2^\beta &= \alpha_B \delta X'_y(\theta_B) \\ \delta S_3^\alpha &= -\alpha_B \delta Y'_x(\theta_B), & \delta S_3^\beta &= \alpha_B \delta Y'_y(\theta_B)\end{aligned}$$

which straightforwardly lead to

$$\mathcal{I}_{\alpha,\beta}^S = |\alpha_B|^2 \mathcal{I}_{A'_x, A'_y}(\theta_B) \equiv |\alpha_B|^2 \mathcal{I}_{+45, -45}(\theta_B)$$

The polarization entanglement condition (6) is thus equivalent to the inseparability criterion (5) for the $\pm 45^\circ$ modes. Therefore, quadrature entanglement can be mapped into a polarization basis and lead to polarization entanglement [6]. Experimentally, we use the set-up shown in Fig. 4 and lock the phase of the B field with the squeezed quadrature angle. We then successively measure the S_2 and S_3 Stokes operator noises using the appropriate combination [5] of plates and PBS. In Fig. 5, we present the normalized quadrature noises of $S_2^\alpha + S_2^\beta$ and $S_3^\alpha + S_3^\beta$ for an analysis frequency of 5 MHz. This entanglement between the beams corresponds to a reduction by approximately 5% in the noise of each variable: $\mathcal{I}_{\alpha,\beta}^S/|\alpha_B|^2 = 1.9$. Moreover, when the two variables are simultaneously squeezed, that is, when both A_x and iA_y are squeezed, we achieve *squeezed-state entanglement*, as defined in [5].

To conclude, we have reported the generation of continuous variable entanglement via the interaction with cold atoms in cavity. First, we have developed a method to directly measure the inseparability criterion [8] and demonstrated quadrature entanglement between two orthogonally polarized modes. Secondly, we achieve polarization entanglement after mapping the quadrature entanglement into two spatially separated beams.

This work was supported by the QIPC European Project No. IST-1999-13071 (QUICOV).

-
- [1] C.H. Bennett *et al.*, Phys. Rev. Lett. **70**, 1895 (1993); S.L. Braunstein, H.J. Kimble, Phys. Rev. A **61**, 042321 (2000); D.P. DiVincenzo, Science **270**, 255 (1995), B. Julsgaard, A. Koshekin, E.S. Polzik, Nature **413**, 400 (2001).
[2] Z.Y. Ou, S.F. Pereira, H.J. Kimble, K.C. Peng, Phys. Rev. Lett. **68**, 3663 (1992).
[3] Y. Zhang, H. Wang, X. Li, J. Jing, C. Xie, K. Peng, Phys. Rev. A **62**, 023813 (2000).

- [4] Ch. Silberhorn, P.K. Lam, O. Weiß, F. Köning, N. Korolkova, G. Leuchs, Phys. Rev. Lett. **86**, 4267 (2001).
[5] N. Korolkova, G. Leuchs, R. Loudon, T.C. Ralph, Ch. Silberhorn, Phys. Rev. A, **65**, 052306 (2002); N. Korolkova, Ch. Silberhorn, O. Glöckl, S. Lorenz, Ch. Marquardt, G. Leuchs, Eur. Phys. J. D **18**, 229 (2002).

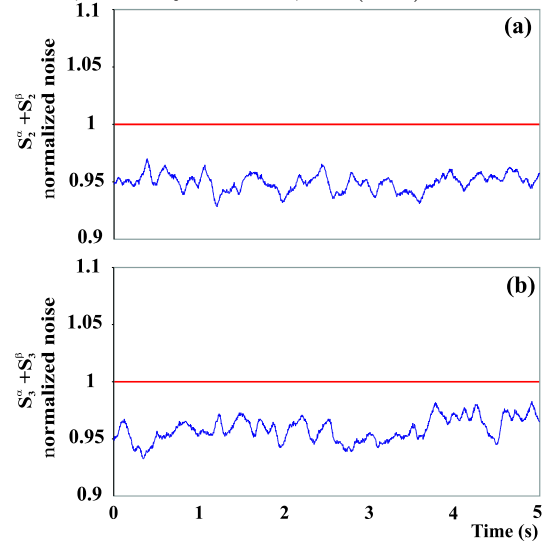

FIG. 5: Normalized noises at 5 MHz of $S_2^\alpha + S_2^\beta$ (a) and $S_3^\alpha + S_3^\beta$ (b), the phase θ_B being locked with the value of the squeezed quadrature angle.

- [6] W.P. Bowen, N. Treps, R. Schnabel, P.K. Lam, Phys. Rev. Lett. **89**, 253601 (2002); W.P. Bowen, R. Schnabel, P.K. Lam, T.C. Ralph, Phys. Rev. Lett. **90**, 043601 (2003).
[7] O. Glöckl, J. Heersink, N. Korolkova, G. Leuchs, S. Lorenz, quant-ph/0302083; O. Glöckl, S. Lorenz, C. Marquardt, J. Heersink, M. Brownnutt, Ch. Silberhorn, Q. Pan, P. van Loock, N. Korolkova, G. Leuchs, quant-ph/0302068.
[8] L.M. Duan, G. Giedke, J.I. Cirac, P. Zoller, Phys. Rev. Lett. **84**, 2722 (2000); R. Simon, Phys. Rev. Lett. **84**, 2726 (2000).
[9] V. Josse, A. Dantan, L. Vernac, A. Bramati, M. Pinard, E. Giacobino, Phys. Rev. Lett. **90**, 103601 (2003).
[10] A. Einstein, B. Podolsky, R. Rosen, Phys. Rev. **47**, 777 (1935).
[11] A. Lambrecht, E. Giacobino, J.M. Courty, Optics Comm. **115**, 199 (1995).
[12] V. Josse, A. Dantan, A. Bramati, M. Pinard, E. Giacobino, J. Opt. B Quantum Semiclassical Opt. **5** S1 (2003).
[13] V. Josse *et al.*, to be published.
[14] L. Longchambon, J. Laurat, T. Coudreau, C. Fabre, in preparation; L. Boivin, H.A. Haus, Optics Lett. **21**, 146 (1996).