



HAL
open science

Lecture notes on mathematical models of interconnected chemostats

Alain Rapaport

► **To cite this version:**

Alain Rapaport. Lecture notes on mathematical models of interconnected chemostats. École thématique. Ecole de recherche du CIMPA, Kenitra, Morocco. 2019, pp.55. cel-02182956

HAL Id: cel-02182956

<https://hal.science/cel-02182956>

Submitted on 14 Jul 2019

HAL is a multi-disciplinary open access archive for the deposit and dissemination of scientific research documents, whether they are published or not. The documents may come from teaching and research institutions in France or abroad, or from public or private research centers.

L'archive ouverte pluridisciplinaire **HAL**, est destinée au dépôt et à la diffusion de documents scientifiques de niveau recherche, publiés ou non, émanant des établissements d'enseignement et de recherche français ou étrangers, des laboratoires publics ou privés.

Lecture notes on mathematical models of interconnected chemostats

Alain Rapaport

CIMPA research school, Kenitra, July 2019

Contents

1	Introduction	4
2	The general model	6
3	Analysis of models with two interconnected vessels	12
3.1	Vessel with a lateral diffusive compartment	13
3.1.1	The limiting cases	14
3.1.2	Study of equilibria	15
3.1.3	Optimal configurations	18
3.1.4	Discussion and interpretation of the results	22
3.2	Which of serial or parallel interconnection is better?	25
3.2.1	The single compartment model	25
3.2.2	The serial configuration	25
3.2.3	The parallel configuration	27
3.2.4	Conclusions	32
3.3	Vessel with a buffer compartment	33
3.3.1	Consideration of growth inhibition	33
3.3.2	Asymptotic behavior	36
3.3.3	Multiplicity of equilibria	39
3.3.4	Discussion	43
A	Appendices	47
A.1	Compartmental and M-matrices	47
A.2	Semi-flows and asymptotically autonomous dynamics	47
A.3	Partial orders and monotone dynamical systems	48
A.4	Stability result for the model with lateral diffusive compartment	49
A.5	Stability result for the model with two vessels in parallel	50
A.6	The buffer tank with non-hyperbolic equilibrium	52
	References	54

Alain Rapaport
MISTEA research unit
2 pl. Vila, 34060 Montpellier, France
email: alain.rapaport@inra.fr

Acknowledgments

The author thanks J.L. Gouzé, J. Harmand, I. Haidar and M. Crespo without whom these notes would not have existed. The author thanks also the support of the French LabEx "NUMEV", incorporated into the I-Site "MUSE".

1 Introduction

The word *gradostat* has been proposed in the eighties by Lovitt and Wimpenny [18, 19] to name an experimental device designed to create artificially a gradient of resources in continuous culture, using several interconnected chemostats. As for the single chemostat, a first vessel is continuously fed with nutrient via an input flow Q , and its volume V is maintained constant by an output flow rate equal to Q . In addition, a series of vessels of same volume V are interconnected with a bidirectional communication rate D (which mimics a diffusion) and creates a gradient of concentrations in the succession of vessels (see Fig. 1). The communication rate D is chosen to be equal to the dilution rate Q/V of the first tank, so that the transfer rate is identical in each tank. This experiment has been the first one to study the impact of a spatial heterogeneity on the growth of micro-organisms in a same common environment (temperature, light, pressure, pH...), and the word "gradostat" echoes the word "chemostat", being dedicated to be studied at steady state with constant "static" gradients. Each vessel is assumed to be perfectly mixed, so that one faces indeed discrete gradients.

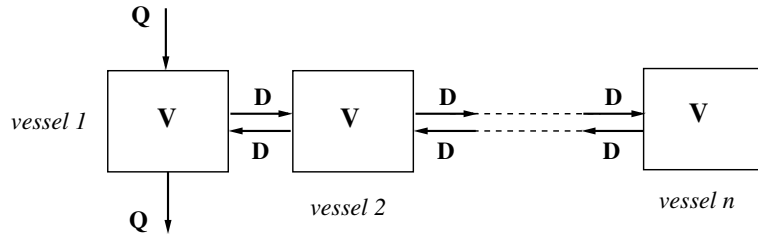

Figure 1: A schematic representation of the gradostat.

This apparatus is described by the gradostat model:

$$\begin{cases} \dot{S}_i = D(S_{i-1} - 2S_i + S_{i+1}) - \frac{1}{Y}R(S_i, X_i) \\ \dot{X}_i = D(X_{i-1} - 2X_i + X_{i+1}) + R(S_i, X_i) \\ S_0 = s_{in}, \quad S_{n+1} = X_0 = X_{n+1} = 0 \end{cases}$$

where S_i and X_i denote the concentrations of substrate and biomass, respectively, in each vessel i . This model has been first analyzed in [34] and further contributions considered extensions with several competing species.

Remark 1.1. *This representation is the spatial discretisation of the well known fractured media model in geo-science (see fig. 2a).*

If x is the direction of the advective flow and y of a fracture of length l , the mass balance give the

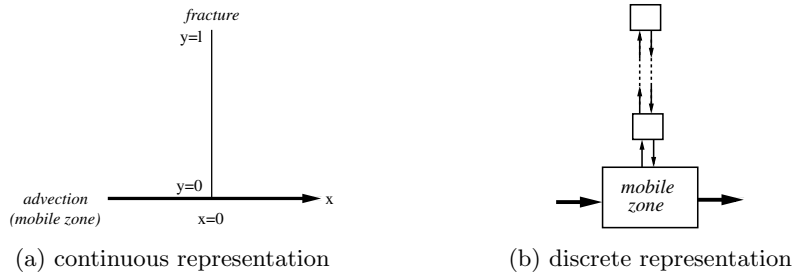

Figure 2: A schematic representation of a fracture.

equations

$$\begin{cases} \partial_t(C_m + \int_0^l C_{im}) = -u\nabla_x C_m + d_m \Delta_x C_m \\ \partial_t C_{im} = d_{im} \Delta_y C_{im} \end{cases}$$

with the boundary conditions

$$\begin{cases} C_m(t, x = 0) = C_{im}(t, y = 0) \\ \nabla_y C_{im}(t, y = l) = 0 \end{cases}$$

where C_m , C_{im} denote the chemical concentrations in the "mobile" and "immobile" zones (see [4, 27]). Here there is no the reaction term. The mobile zone is approximated by a perfectly mixed tank (the first vessel), and the immobile zone by a series of small volumes (see Fig. 2b).

There exist several variants of this model for representing more general situations such as in biotechnological industry (for large bioreactors that exhibit spatial heterogeneity, interconnected bioreactors...) or in natural environments (soils, porous media...), with

- different volumes and communication rates of the vessels,
- output flow located at different vessels than the input one,
- several input and output flows,

...

All those more general models are usually enclosed in the wording *general gradostat*, which describes a more general class of interconnected chemostats. In the original description of Lovitt & Wimpenny, the possibility of having two different essential resources fed independently in the vessels at the extremities of the chain are considered (see Fig. 3). However, in these notes, we

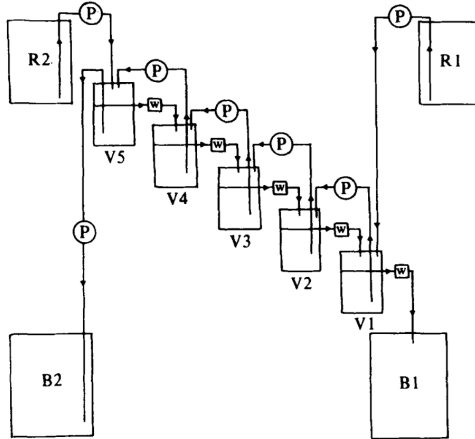

Figure 3: The original description by Lovit and Wimpenny (from [19]).

shall consider only **one limiting resource** S .

In the next section, we study general properties of the solutions of general gradostat model, for an arbitrary number of vessels. The complete analytical analysis of the input-output performances of the general chemostat is today an open problem, although it can be easily determined numerically, for each given structure. In the review paper [30], H. Smith wrote "In the two vessels case, the results are complete and the conditions are testable... In the most general setting, some of the computations cannot be carried out explicitly (although any specific ease could be done numerically)". In the following sections, we study how a spatial structure can impact locally the input-output performances, comparing all the possible connections between two adjacent vessels.

2 The general model

This section has been prepared with J.L. Gouzé.

We consider a network of n interconnected chemostats, and assume that a same single species is present in each vessel at initial time. The network is fed with a single limiting resource that allows the growth of the bacterial species. The nodes of the interconnection graph is composed of the tanks of volume denoted by $V_i > 0$ ($i = 1 \dots n$), and the arcs represent mass transfers between the tanks (see an example on Fig. 4).

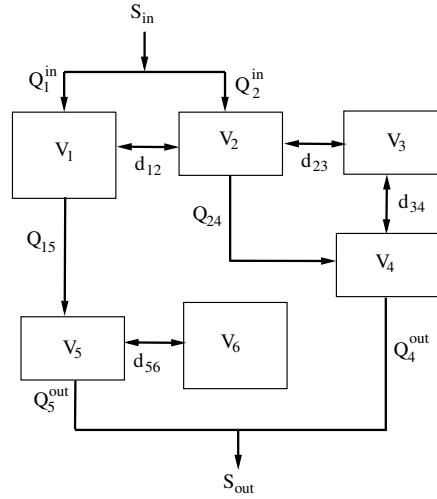

Figure 4: Example of a "general" gradostat

We consider four types of arcs (see Fig. 5):

- flux of flow rate $Q_{ij} \geq 0$ from node i to j with $j \neq i$ ($Q_{ij} = 0$ if there is no flux from vessel i to vessel j),
- Fick diffusion of parameter $d_{ij} = d_{ji} \geq 0$ between nodes i and j with $j \neq i$ (with $d_{ij} = 0$ if there is no diffusion between vessels i and j),
- output flow $Q_i^{out} \geq 0$ from node i (with $Q_i^{out} = 0$ if there is no output flow from vessel i),
- input flow $Q_i^{in} \geq 0$ to node i (with $Q_i^{in} = 0$ if there is no input flow to vessel i),

and assume that the Kirchoff law or mass conservation is satisfied at each node.

Hypothesis H0.

$$\sum_{j \neq i} Q_{ji} + Q_i^{in} = \sum_{k \neq i} Q_{ik} + Q_i^{out}, \quad \forall i = 1 \dots n$$

Notice that summing the above equality on all i imposes the input-output conservation of the total flow rate:

$$\sum_i Q_i^{in} = \sum_i Q_i^{out} := Q.$$

We denote by I and O the sets of input and output nodes:

$$I = \{i \in 1 \dots n \mid Q_i^{in} > 0\}, \quad O = \{i \in 1 \dots n \mid Q_i^{out} > 0\} \quad (1)$$

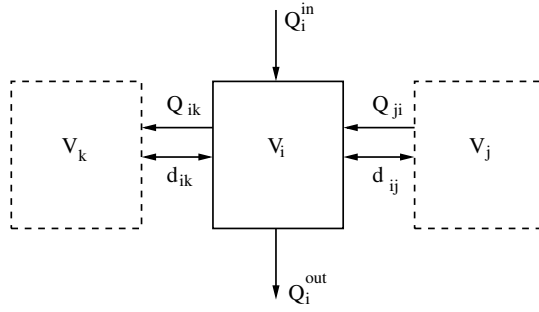

Figure 5: The possible flows about one vessel.

We shall represent by S and X respectively the vectors of concentrations of the limiting resource and biomass in the set of tank. The time evolution of these vectors is modeled by a dynamical system of the form

$$\begin{cases} \dot{S} = -\frac{1}{y}R(S, X) + MS + DS^{in} \\ \dot{X} = R(S, X) + MX + DX^{in} \end{cases} \quad (2)$$

where $y > 0$ and $R(\cdot)$ stand respectively for the conversion yield of the species, and the vector of kinetics that occurs in each vessel. The matrices M and D represent respectively the mass transfers and inputs and are defined as follows:

$$M_{ij} = \begin{cases} -\frac{1}{V_i} \left(\sum_{k \neq i} Q_{ik} + d_{ik} + Q_i^{out} \right), & \text{when } i = j \\ \frac{1}{V_i} (Q_{ji} + d_{ij}), & \text{when } i \neq j \end{cases} \quad (3)$$

$$D = \text{diag} \left(\left\{ \frac{Q_i^{in}}{V_i} \right\}_i \right) \quad (4)$$

Remark 2.1. One can check that the parameter y can be chosen equal to one without any loss of generality, simply replacing X_i/y by X_i in equations (2). Consequently, we shall omit y in the following.

Remark 2.2. It often happens that each entry node receives the same substrate concentration s_{in} (with or without the same input concentration of biomass), which amounts to consider the vector S_{in} such that $S_i^{in} = s_{in}$ for any $i = 1 \dots n$. It also often happens to consider the output substrate concentration s_{out} defined as

$$s_{out} = \frac{\sum_i Q_i^{out} S_i}{\sum_i Q_i^{out}}$$

which allows to consider the system as an "input-output" map $s_{in} \mapsto s_{out}$. Properties of this map will be studied in more details for the two vessels cases in the next section.

Classically, we assume the kinetics to be linear w.r.t. to the biomass concentration and characterized by a specific growth rate $\mu(\cdot)$:

$$R_i(S, X) = \mu(S_i)X_i, \quad \forall i = 1 \dots n \quad (5)$$

We shall assume that the function $\mu(\cdot)$ is smooth (at least C^2) with $\mu(0) = 0$ and $\mu(S) > 0$ for $S > 0$.

This model is an attempt to represent and study spatial inhomogeneity.

An example. The network depicted on Fig. 4 leads to the following dynamical equations.

$$\begin{aligned}
\dot{S}_1 &= -\mu(S_1)X_1 + \frac{1}{V_1}(Q_1^{in}S^{in} - Q_{15}S_1) + \frac{d_{12}}{V_1}(S_2 - S_1) \\
\dot{X}_1 &= \mu(S_1)X_1 - \frac{1}{V_1}Q_{15}X_1 + \frac{d_{12}}{V_1}(X_2 - X_1) \\
\dot{S}_2 &= -\mu(S_2)X_2 + \frac{1}{V_2}(Q_2^{in}S^{in} - Q_{24}S_2) + \frac{d_{12}}{V_2}(S_1 - S_2) + \frac{d_{23}}{V_2}(S_3 - S_2) \\
\dot{X}_2 &= \mu(S_2)X_2 - \frac{1}{V_2}Q_{24}X_2 + \frac{d_{12}}{V_2}(X_1 - X_2) + \frac{d_{23}}{V_2}(X_3 - X_2) \\
\dot{S}_3 &= -\mu(S_3)X_3 + \frac{d_{23}}{V_3}(S_2 - S_3) + \frac{d_{34}}{V_3}(S_4 - S_3) \\
\dot{X}_3 &= \mu(S_3)X_3 + \frac{d_{23}}{V_3}(X_2 - X_3) + \frac{d_{34}}{V_3}(X_4 - X_3) \\
\dot{S}_4 &= -\mu(S_4)X_4 + \frac{1}{V_4}(Q_{24}S_2 - Q_4^{out}S_4) + \frac{d_{34}}{V_4}(S_3 - S_4) \\
\dot{X}_4 &= \mu(S_4)X_4 + \frac{1}{V_4}(Q_{24}X_2 - Q_4^{out}X_4) + \frac{d_{34}}{V_4}(X_3 - X_4) \\
\dot{S}_5 &= -\mu(S_5)X_5 + \frac{1}{V_5}(Q_{15}S_1 - Q_5^{out}S_5) + \frac{d_{56}}{V_5}(S_6 - S_5) \\
\dot{X}_5 &= \mu(S_5)X_5 + \frac{1}{V_5}(Q_{15}X_1 - Q_5^{out}X_5) + \frac{d_{56}}{V_5}(X_6 - X_5) \\
\dot{S}_6 &= -\mu(S_6)X_6 + \frac{d_{56}}{V_6}(S_5 - S_6) \\
\dot{X}_6 &= \mu(S_6)X_6 + \frac{d_{56}}{V_6}(X_5 - X_6)
\end{aligned}$$

with $Q_{15} = Q_1^{in}$, $Q_{24} = Q_2^{in}$, $Q_5^{out} = Q_{15}$, $Q_4^{out} = Q_{24}$ to respect the mass balance. The output concentration is given by

$$S^{out} = \frac{Q_5^{out}S_5 + Q_6^{out}S_6}{Q_5^{out} + Q_6^{out}}$$

For this model, the matrix representation is given by:

$$M = \begin{bmatrix} -\frac{Q_{15}+d_{12}}{V_1} & \frac{d_{12}}{V_1} & 0 & 0 & 0 & 0 \\ \frac{d_{12}}{V_2} & -\frac{Q_{24}+d_{12}+d_{23}}{V_2} & \frac{d_{23}}{V_2} & 0 & 0 & 0 \\ 0 & \frac{d_{23}}{V_3} & -\frac{d_{23}+d_{34}}{V_3} & \frac{d_{34}}{V_3} & 0 & 0 \\ 0 & \frac{Q_{24}}{V_4} & \frac{d_{34}}{V_4} & -\frac{d_{34}}{V_4} & 0 & 0 \\ \frac{Q_{15}}{V_5} & 0 & 0 & 0 & -\frac{d_{56}}{V_5} & \frac{d_{56}}{V_5} \\ 0 & 0 & 0 & 0 & \frac{d_{56}}{V_6} & -\frac{d_{56}}{V_6} \end{bmatrix}$$

$$D = \begin{bmatrix} \frac{Q_1^{in}}{V_1} & & & & & \\ & \frac{Q_2^{in}}{V_2} & & & & \\ & & 0 & & & \\ & & & 0 & & \\ & & & & 0 & \\ & & & & & 0 \end{bmatrix}, \quad C = \begin{bmatrix} 0 & 0 & 0 & \frac{Q_4^{out}}{Q_4^{out}+Q_5^{out}} & \frac{Q_5^{out}}{Q_4^{out}+Q_5^{out}} & 0 \end{bmatrix}$$

We give now general properties of the matrix M .

Lemma 2.1. *Under H_0 , the matrix M is compartmental (the definition is recalled in Appendix A.1).*

Proof. Properties $M_{ii} \leq 0$ and $M_{ij} \geq 0$ for $j \neq i$ are fulfilled from the definition (3). For any i , one has

$$\sum_j M_{ij} = \frac{1}{V_i} \left[\sum_{j \neq i} Q_{ji} + d_{ij} - \sum_{k \neq i} (Q_{ik} + d_{ik}) - Q_i^{out} \right]$$

and under Hypothesis H0, one obtains

$$\sum_j M_{ij} = -\frac{Q_i^{in}}{V_i}$$

Then the property $\sum_j M_{ij} \leq 0$ is fulfilled. \square

In the following, we assume that there is no loop in the network that is not connected to the set O . This property of the graph is often called "outflow-connected".

Hypothesis H1. The sets I and O are non-empty and for any $i \notin O$ there exists $j \in O$ and a sequence i_0, \dots, i_k such that $i_0 = i$, $i_k = j$ with $M_{i_\alpha i_{\alpha+1}} > 0$.

Remark 2.3. Hypothesis H1 does not imply that the matrix M has to be irreducible. For instance the matrix M in the previous example is reducible, but the network is outflow connected.

For convenience, we posit the vector $Z^{in} = S^{in} + X^{in}$.

Proposition 2.1. Assume that Hypotheses H0-H1 are fulfilled. The positive domain $\mathcal{D} = \mathbb{R}^{2n}$ is invariant by the dynamics (2), and any solution in \mathcal{D} is bounded. Furthermore, the matrix M is invertible and any solution of the system (2) verifies

$$\lim_{t \rightarrow +\infty} S(t) + X(t) = -M^{-1}DZ^{in} \quad (6)$$

Proof. From equations (2) and the property that matrix M has non-negative off-diagonal terms, one deduces the following inequalities

$$S_i = 0 \Rightarrow \dot{S}_i \geq 0, \quad X_i = 0 \Rightarrow \dot{X}_i \geq 0$$

and conclude that the domain \mathcal{D} is invariant by the dynamics (2).

Consider the vector $Z = S + X$. One has straightforwardly

$$\dot{Z} = MZ + DZ^{in} \quad (7)$$

We recall that for a compartmental matrix, Hypothesis H1 implies that the matrix M is non-singular and Hurwitz (see Theorem A.1.1 in Appendix A.1). We can then deduce the asymptotic property of solutions of system (7).

$$\lim_{t \rightarrow +\infty} Z(t) = \bar{Z} = -M^{-1}DZ^{in} \quad (8)$$

Furthermore, a non-singular compartmental matrix being diagonal dominant, $-M$ is a M-matrix. The components of the vector DZ^{in} being non-negative, the properties of the M-matrices (see Theorem A.1.2 in Appendix A.1) implies then the vector \bar{Z} has non-negative components. Finally, we deduce the boundedness of the vectors S and X . \square

Let us write dynamics (2) in (Z, X) coordinates with $Z = S + X$.

$$\begin{cases} \dot{Z} = M(\bar{Z} - Z) \\ \dot{X} = R(Z - X, X) + MX + DX^{in} \end{cases} \quad (9)$$

where $\bar{Z} = -M^{-1}DZ^{in}$. One notice that the system presents a cascade structure, and from Proposition 2.1, any solution of the first Z -system converges globally toward \bar{Z} . We can then consider the reduced dynamics

$$\dot{X} = F(X) := \bar{R}(X) + MX + DX^{in} \quad (10)$$

where

$$\bar{R}(X) = R(\bar{Z} - X, X)$$

Indeed, the original dynamics in X can be written as an *asymptotically autonomous* dynamics: $\dot{X} = R(Z(t) - X, X) + MX + DX^{in}$ whose limit is $\dot{X} = F(X)$. The asymptotic properties of its bounded solutions are then given by the ones of the reduced dynamics (see Appendix A.2). Notice that the vector $\bar{R}(\cdot)$ has the particular decoupled form

$$\bar{R}_i(X) = r_i(X_i) = \mu(\bar{Z}_i - X_i)X_i \quad (11)$$

Take $\epsilon > 0$ and define the number

$$v = \left[\max \left(1, \max_i \max_{X_i \in [0, \bar{Z}_i]} -r'_i(X_i) - M_{ii} + \epsilon \right) \right]^{-1} \quad (12)$$

Then, we consider the map $T(X) = vF(X) + X$ and write the dynamics (10) in time $\tau = vt$ as follows

$$\frac{dX}{d\tau} = T(X) - X \quad (13)$$

Equilibrium points of dynamics (10) are then exactly the fixed points of the map T .

Hypothesis H2. Each functions r_i ($i = 1 \dots n$) are strictly concave on the domains $[0, \bar{Z}_i]$.

Remark 2.4. From the equation (11), one can write

$$r''_i(X_i) = \mu''(\bar{Z}_i - X_i)X_i - 2\mu'(\bar{Z}_i - X_i)$$

and check that Hypothesis H2 is fulfilled when the function μ is concave increasing. This is typically the case for the Monod function:

$$\mu(S) = \frac{\mu_{\max}S}{K + S}$$

We shall also assume that input flow brings mass in any tank.

Hypothesis H3. Under Hypotheses H0, H1, we assume $\bar{Z} = -M^{-1}DZ^{in} > 0$.

In the following, we shall denote $[0, \bar{Z}]$ for the cartesian product $[0, \bar{Z}_1] \times \dots \times [0, \bar{Z}_n]$, and $[\text{Jac } f(x)]$ for the Jacobian matrix of a map f from \mathbb{R}^n to \mathbb{R}^n at a point x .

Lemma 2.2. Under Hypotheses H0-H1-H2-H3, the map T is non-decreasing on $[0, \bar{Z}]$ i.e.

$$[\text{Jac } T(X)] \geq 0, \quad \forall X \in [0, \bar{Z}] \quad (14)$$

and one has $T([0, \bar{Z}]) \subset [0, \bar{Z}]$. Furthermore T fulfills the property

$$T(\lambda X) > \lambda T(X), \quad \forall X > 0, \quad \forall \lambda \in (0, 1) \quad (15)$$

Proof. One has

$$[\text{Jac } T(X)] = v(\text{diag}(\{r'_i(X_i)\}_i) + M) + I \quad (16)$$

By definition, one has $M_{ij} \geq 0$ when $i \neq j$, and the choice of the number v implies

$$v(r'_i(X_i) + M_{ii}) + 1 > 0, \quad \forall X \in [0, \bar{Z}]$$

So property (14) is fulfilled. Furthermore, one has

$$T(0) = DX^{in} \geq 0$$

and

$$T(\bar{Z}) = -vDS_{in} + \bar{Z} \leq \bar{Z}$$

from which one deduces $T([0, \bar{Z}]) \subset [0, \bar{Z}]$.

Take $X > 0$ and $\lambda \in (0, 1)$. On has

$$T(\lambda X) = v(\bar{R}(\lambda X) + \lambda MX + DX^{in}) + \lambda X$$

From Hypothesis H2, one can write

$$\bar{R}(\lambda X) > \lambda R(X) + (1 - \lambda)R(0) = \lambda R(X)$$

and consequently

$$T(\lambda X) > \lambda T(X) + vDX^{in}(1 - \lambda) > \lambda T(X)$$

□

Proposition 2.2. *Under Hypothesis H0-H1-H2-H3, there exists at most one positive fixed point of T on $[0, \bar{Z}]$.*

Proof. Assume that X and Y are two distinct positive fixed points of T in $[0, \bar{Z}]$. At the price to exchange X and Y , one can assume that there exists i such that $X_i > Y_i$. Then, consider the number

$$\lambda = \min_i \frac{Y_i}{X_i}$$

Necessarily $\lambda \in (0, 1)$ and one has $\lambda X \leq Y$ with

$$i^* \in \arg \min_i \frac{Y_i}{X_i} \Rightarrow \lambda X_{i^*} = Y_{i^*} \quad (17)$$

Using Lemma 2.2, one can write

$$Y = T(Y) \geq T(\lambda X) > \lambda T(X) = \lambda X$$

this last strict inequality contradicting (17). □

Proposition 2.3. *Assume that Hypotheses H0-H1-H2-H3 are fulfilled. When $\mu(\bar{Z}_i) > -M_{ii}$ for any $i = 1 \dots n$, there exists a positive vector X^* in $[0, \bar{Z}]$ such that any solution of (10) with a positive initial condition in $[0, \bar{Z}]$ converges asymptotically to X^* .*

Proof. Notice that $F(0) = DX_{in} \geq 0$ and $DF(0) = \text{diag}(\{\mu(\bar{Z}_i)\}_i) + M$. By assumption, one has $DF(0)\Delta > 0$ for any $\Delta > 0$, and by continuity of $F(\cdot)$, we deduce that there exists $\underline{X} > 0$ such that

$$0 < X \leq \underline{X} \implies F(X) > 0 \quad (18)$$

Notice also that one has

$$F(\bar{Z}) = -DS_{in} \leq 0 \quad (19)$$

Consider $X_0 > 0$ in $[0, \bar{Z}]$ and denote by $X(\cdot)$ the solution of $\dot{X} = F(X)$ with $X(0) = X_0$. Define $X^-(\cdot)$, $X^+(\cdot)$ the solutions of $\dot{X} = F(X)$ with $X^-(0) = \min(X_0, \underline{X}) > 0$ and $X^+(0) = \bar{Z}$ respectively.

As $[\text{Jac } F(X)]_{ij} = M_{ij} \geq 0$ for any $i \neq j$, the dynamics $\dot{X} = F(X)$ is cooperative (definition and properties of cooperative dynamics are recalled in Appendix A.3) and the following framing is then fulfilled

$$X^-(t) \leq X(t) \leq X^+(t), \quad \forall t > 0 \quad (20)$$

Denote $V^\pm(t) = \dot{X}^\pm(t)$, which are solutions of the non-autonomous dynamics

$$\dot{V}^\pm = [\text{Jac } F(X^\pm(t))] \cdot V^\pm \quad (21)$$

Notice that (18) and (19) imply $V^-(0) = F(X^-(0)) > 0$ and $V^+(0) = F(\bar{Z}) \leq 0$. The dynamics (21) being cooperative, one deduces by Theorem A.3.1 (see Appendix A.3) the vectorial inequalities:

$$V^-(t) > 0, \quad V^+(t) \leq 0, \quad \forall t > 0$$

Consequently, each component of the vectors X^- and X^+ are monotonic bounded functions of time. Then $X_-(\cdot)$ and $X_+(\cdot)$ converge asymptotically towards steady states X^{-*} , X^{+*} in $[0, \bar{Z}]$ such that

$$0 < X^{-*} \leq X^{+*} \leq \bar{Z}$$

By Proposition 2.2, we conclude that $X^{-*} = X^{+*}$ is the unique positive equilibrium X^* of the dynamics F in $[0, \bar{Z}]$. Finally, property (20) allows to conclude and that

$$\lim_{t \rightarrow +\infty} X(t) = X^* .$$

□

Remark 2.5. *Hypotheses of Proposition 2.3 do not prevent the existence of equilibriums $X^* \neq 0$ on the boundaries of the domain $[0, \bar{Z}]$ but they are all repulsive.*

3 Analysis of models with two interconnected vessels

Given an input and an output of a system of two interconnected tanks, we consider in this section its performances either in terms of

- conversion ratio s_{out}/s_{in} (at steady state), given an input flow rate Q and a total volume V ,

or

- residence time $\bar{t} = V/Q$, provided a given conversion ratio s_{out}/s_{in} (at steady state),

to be minimized, which are the usual criteria in water treatments (such as decontamination by bacteria).

Remark 3.1. *The "mean residence time" of a process is commonly defined as*

$$\bar{t} = \frac{\int_0^{+\infty} t s_{out}(t) dt}{\int_0^{+\infty} s_{out}(t) dt}$$

when at time 0 there is a uniform unitary concentration of the resource (in each tank) with no biological activity and input concentration at any future time. One can easily show that $\bar{t} = V/Q$ where V is the total volume, whatever is the spatial configuration. More details about the mean residence time can be found for instance in [24, Chapter 15].

For other applications, in biotechnological or agro-food industry, different criteria, such as productivity (quantity of biomass produced during a given period of time) or output flow-rate of biogas (as a by-product of the bioreaction), to be maximized, are relevant (but that we do not consider here).

With two tanks, interconnections can be made in series or in parallel. However, we shall distinguish four cases, as depicted on Fig. 6. Cases a) and b) are the classical serial and parallel configurations. In case c), the second tank plays the role of a "buffer". This case can be seen as an extension of case a) when the secondary tank receives in addition part of the input flow. Case d) is a particular case of case b) with $\alpha = 1$. However, this particular configuration is widely used to model heterogeneity in single tank, and deserves to be studied independently. This is why we dedicate a thorough analysis in the sub-section. Notice that this configuration is indeed the classical gradostat (see Fig. 1) with only one lateral tank but that could be here of different volume.

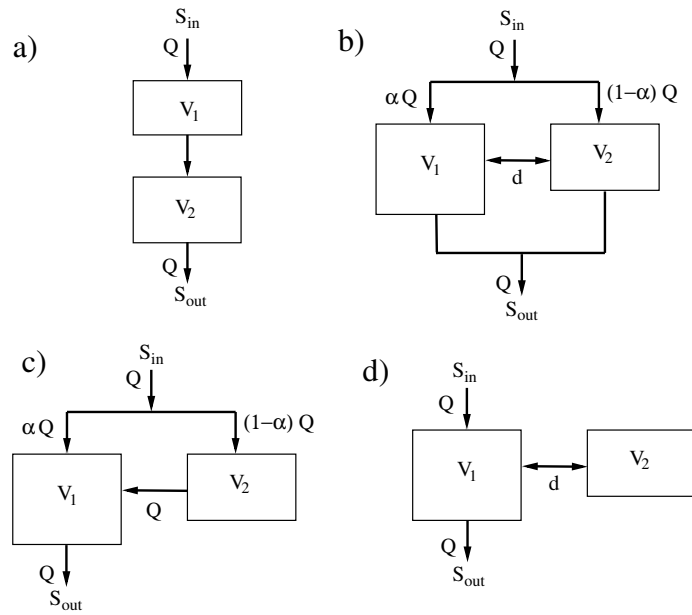

Figure 6: Four kinds of interconnections of two vessels.

3.1 Vessel with a lateral diffusive compartment

This section has been inspired by [3].

In industrial processes, it often happens that reactors with large volumes are not perfectly mixed, even when using agitators. “Dead zones” are then observed, so that the effective volumes have to be corrected in the models to provide accurate predictions [17, 6].

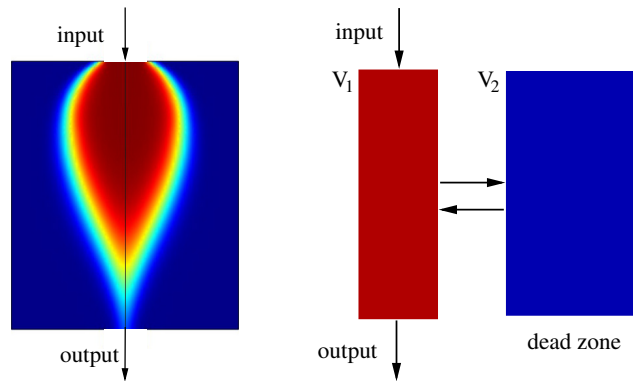

Figure 7: A “dead-zone” representation (right) is a simple way to model two areas in a bioreactor: convection dominated versus diffusion dominated (left).

Segregated habitats are also considered in lakes, where the bottom can be modeled as a dead zone with nutrient mixing between bottom and top achieved by diffusion [23]. In a similar way, stagnant or “immobile” zones are known to occur in porous media such as in soils, at various extents depending on soil structure. The effect of these dead zones on reactive and conservative mass transport, and thus in turn on the bio-geochemical cycles of elements, can be significant [35, 28]. The wording “dead-zone” might be slightly miss-leading as it can make believe that part

of the tank where there is no advection stream from the input flow has no biological activity. But this does not necessarily mean that these "dead-zones" are entirely disconnected from other parts of the reactor. It is simply likely to be influenced by diffusion and not convection. May be, its is preferable to qualify these zones as "lateral-diffusive compartments" (the adjective "lateral" underlying that the connection is not in the direction of the flow).

We then consider configurations of a main tank of volume V_1 , subject to input and output flows, interconnected by Fickian diffusion with a secondary tank of volume V_2 , as depicted on Figure 6d). The equations of the model are

$$\begin{cases} \dot{s}_1 &= -\mu(s_1)x_1 + \frac{Q}{V_1}(s_{\text{in}} - s_1) + \frac{d}{V_1}(s_2 - s_1) \\ \dot{x}_1 &= \mu(s_1)x_1 - \frac{Q}{V_1}x_1 + \frac{d}{V_1}(x_2 - x_1) \\ \dot{s}_2 &= -\mu(s_2)x_2 + \frac{d}{V_2}(s_1 - s_2) \\ \dot{x}_2 &= \mu(s_2)x_2 + \frac{d}{V_2}(x_1 - x_2) \end{cases} \quad (22)$$

where we have assumed, without any loss of generality, that the yield conversion factor of substrate into biomass is equal to 1. The parameters Q and s_{in} denote the flow rate and substrate concentration of the input stream, while the parameter $d > 0$ is the diffusion coefficient between the two tanks (that we assume to be identical for the substrate and the micro-organisms). The specific growth rate function of the micro-organisms, denoted by μ , fulfills the classical assumption, as considered in Section 2.

Hypothesis H2b. The growth function $\mu(\cdot)$ is an increasing concave function with $\mu(0) = 0$.

Let us first discuss the modeling of the two limiting cases that are not covered by system (22).

3.1.1 The limiting cases

1. $V_1 = 0$. Physically, this corresponds to a single tank (of volume V_2) connected by diffusion to the input pipe with flow rate Q (see Figure 8). Water charged with substrate at a concentration s_{in} flows with rate Q along a pipe, which is connected laterally with a vessel through a diffusion rate d . Substrate reacts with biomass at the tank and leaves the pipe with flow rate Q .

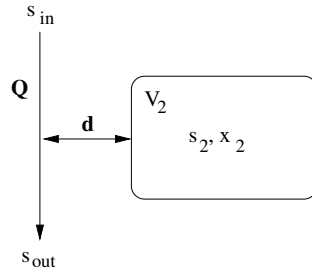

Figure 8: Representation of the chemostat into consideration in the limiting case when $V_1 = 0$.

There is no biological activity in the pipe but simply a dilution given by the mass balance at the connection point:

$$\begin{cases} Q(s_{\text{in}} - s_{\text{out}}) = d(s_{\text{out}} - s_2) \\ -Qx_{\text{out}} = d(x_{\text{out}} - x_2) \end{cases} \Rightarrow s_{\text{out}} = \frac{Qs_{\text{in}} + ds_2}{Q + d}, x_{\text{out}} = \frac{dx_2}{Q + d} \quad (23)$$

Then the dynamics in the tank with (s_{out}, x_{out}) instead of (s_1, x_1) is given by the equations

$$\begin{cases} \dot{s}_2 &= -\mu(s_2)x_2 + \frac{Qd}{(Q+d)V_2}(s_{in} - s_2) \\ \dot{x}_2 &= \mu(s_2)x_2 - \frac{Qd}{(Q+d)V_2}x_2 \end{cases}$$

This is equivalent to have a single tank of volume V_2 with input flow rate $Qd/(Q+d)$ but with an output given by $s_{out} = (Qs_{in} + ds_2)/(Q+d)$.

2. $V_2 = 0$. The dynamics of (s_1, x_1) is the one of the single chemostat model with volume V_1

$$\begin{cases} \dot{s}_1 &= -\mu(s_1)x_1 + \frac{Q}{V_1}(s_{in} - s_1) \\ \dot{x}_1 &= \mu(s_1)x_1 - \frac{Q}{V_1}x_1 \end{cases} \quad (24)$$

This is also equivalent to having no diffusion ($d = 0$) between the tanks.

3.1.2 Study of equilibria

From Proposition 2.2 of Section 2, we know that there exists at most one positive equilibrium of the system, the author equilibrium $E^0 = (0, s_{in}, 0, s_{in})^\top$ being the washout in both tank. Moreover Proposition 2.3 of Section 2 gives $\mu(s_{in}) > Q/V_1$ as a sufficient condition for the existence of the positive equilibrium, which is then necessarily asymptotically stable, globally on the positive orthant. However, Proposition 2.3 gives only a sufficient condition. We give now a necessary and sufficient condition for the existence of the positive equilibrium.

It is convenient to introduce the function

$$\beta(s) = \mu(s)(s_{in} - s) \quad (25)$$

that satisfies the following property.

Lemma 3.1.1. *Under Hypothesis H2b, the function β is strictly concave on $[0, s_{in}]$. Thus, one can define the unique value*

$$\hat{s} = \arg \max_{s \in (0, s_{in})} \beta(s). \quad (26)$$

Proof. One has $\beta'(s) = \mu'(s)(s_{in} - s) - \mu(s)$ and $\beta''(s) = \mu''(s)(s_{in} - s) - 2\mu'(s)$, which is negative for any $s \in [0, s_{in}]$. \square

Given parameters V_1, V_2, Q and d , let us define the following polynomial:

$$P(X) = V_1V_2X^2 - (dV_1 + (Q+d)V_2)X + dQ$$

The next proposition reveals the role played by the polynomial P in the characterization of positive equilibria, given a prescribed value of input concentration s_{in} .

Proposition 3.1.1. *The washout equilibrium E^0 is the unique steady state of (22) exactly when s_{in} satisfies the condition*

$$\mu(s_{in}) \leq \frac{Q}{V_1} \text{ and } P(\mu(s_{in})) \geq 0. \quad (27)$$

When condition (27) is not fulfilled, there exists an unique positive steady state E^ of (22) distinct from E^0 .*

Proof. From the two last equations of (22), one has $s_1 + x_1 = s_2 + x_2$ at steady-state, and from the two first ones $s_1 + x_1 = s_{\text{in}}$. The values s_1, s_2 at steady state are then solutions of the system of two equations

$$0 = \left(\frac{Q}{V_1} - \mu(s_1) \right) (s_{\text{in}} - s_1) + \frac{d}{V_1} (s_2 - s_1) \quad (28)$$

$$0 = -\mu(s_2)(s_{\text{in}} - s_2) + \frac{d}{V_2} (s_1 - s_2) \quad (29)$$

and x_1, x_2 at steady state are uniquely defined from each solution (s_1, s_2) of (28)-(29).

Clearly $(s_{\text{in}}, s_{\text{in}})$ is a solution of (28)-(29). We look for (positive) solutions different to $(s_{\text{in}}, s_{\text{in}})$. Posit

$$\lambda_1(s_{\text{in}}) := \max \left\{ s_1 \in [0, s_{\text{in}}] \mid \mu(s_1) \leq \frac{Q}{V_1} \right\}$$

From equations (28)-(29), a solution different to $(s_{\text{in}}, s_{\text{in}})$ has to satisfy $s_1 > s_2 > 0$ and then from equation (28), one has also $s_1 < \lambda_1(s_{\text{in}})$. Define then the functions:

$$\phi_1(s_1) := s_1 - \frac{Q - V_1\mu(s_1)}{d} (s_{\text{in}} - s_1) = s_1 - \frac{Q}{d} (s_{\text{in}} - s_1) + \frac{V_1}{d} \beta(s_1), \quad (30)$$

$$\phi_2(s_2) := s_2 + \frac{V_2\mu(s_2)}{d} (s_{\text{in}} - s_2) = s_2 + \frac{V_2}{d} \beta(s_2). \quad (31)$$

so that any solution of (28)-(29) fulfills $s_2 = \phi_1(s_1)$ and $s_1 = \phi_2(s_2)$. One has

$$\phi_1'(s_1) = 1 + \frac{V_1}{d} \mu'(s_1)(s_{\text{in}} - s_1) + \frac{Q - V_1\mu(s_1)}{d}.$$

Therefore ϕ_1 is increasing on $[0, \lambda_1(s_{\text{in}})]$, with $\phi_1(0) = -(Q/d)s_{\text{in}} < 0$ and $\phi_1(\lambda_1(s_{\text{in}})) = \lambda_1(s_{\text{in}}) > 0$. Thus, ϕ_1 is invertible on $[-(Q/d)s_{\text{in}}, \lambda_1(s_{\text{in}})]$ with

$$\phi_1^{-1}(0) \in (0, \lambda_1(s_{\text{in}})).$$

From Lemma 3.1.1, it follows that ϕ_1 and ϕ_2 are strictly concave functions on $[0, s_{\text{in}}]$. Consider then the function

$$\gamma(s_2) := \phi_2(s_2) - \phi_1^{-1}(s_2) \quad s_2 \in [0, \lambda_1(s_{\text{in}})], \quad (32)$$

which is also strictly concave on $[0, \lambda_1(s_{\text{in}})]$. Then, a solution (s_1, s_2) can be written as a solution of

$$\gamma(s_2) = 0, \quad s_1 = \phi_2(s_2) \quad \text{with } s_2 \in [0, \lambda_1(s_{\text{in}})].$$

Notice that one has $\gamma(0) = -\phi_1^{-1}(0) < 0$. We distinguish two cases:

– When $\lambda_1(s_{\text{in}}) < s_{\text{in}}$ (or equivalently $\mu(s_{\text{in}}) > Q/V_1$), one has

$$\gamma(\lambda_1(s_{\text{in}})) = \frac{QV_2}{dV_1} (s_{\text{in}} - \lambda_1(s_{\text{in}})) > 0.$$

By using the Mean Value Theorem, one concludes that there exists $s_2 \in (0, \lambda_1(s_{\text{in}}))$ such that $\gamma(s_2) = 0$. As γ is strictly concave, s_2 is unique.

– When $\lambda_1(s_{\text{in}}) = s_{\text{in}}$ (that is when $\mu(s_{\text{in}}) \leq Q/V_1$), one has $\gamma(s_{\text{in}}) = s_{\text{in}}$ and the function γ takes positive values on the interval $[0, s_{\text{in}}]$ if and only if $\gamma'(s_{\text{in}}) < 0$ (γ being strictly concave on $[0, s_{\text{in}}]$), or equivalently when the condition

$$\phi_2'(s_{\text{in}}) < \frac{1}{\phi_1'(s_{\text{in}})}$$

is fulfilled. Then, there exists a unique solution to $\gamma(s_2) = 0$ on $(0, s_{in})$. Notice that one has $\phi_1'(s_{in}) > 0$ because $\lambda_1(s_{in}) = s_{in}$. So the condition can be also written as $\phi_1'(s_{in})\phi_2'(s_{in}) < 1$. From the expressions of ϕ_1 and ϕ_2 , one can write this condition as

$$\frac{(d + Q - V_1\mu(s_{in}))(d - V_2\mu(s_{in}))}{d^2} < 1,$$

and check that this exactly amounts to require s_{in} to satisfy $P(\mu(s_{in})) < 0$. We conclude that there exists a positive steady state if and only if $\mu(s_{in}) > Q/V_1$ or $P(\mu(s_{in})) < 0$ and that this steady state (when it exists) is unique. \square

This result shows that in the case when $\mu(s_{in}) > Q/V_1$, that would conduct the system to the washout in the first vessel without the connection to the second vessel, the lateral diffusive compartment can play the role of a "refuge", avoiding the washout. Proposition 2.3 does not give the global convergence in this case. The proof of the global stability for the lateral diffusive compartment is left in Appendix A.4.

One can guess the existence of a compromise with a "dead-zone" penalizing the conversion ratio, as the volume in the main tank is smaller on one hand, but proving robustness against wash-out on another hand. To formulate it more precisely, we investigate how a lateral diffusive compartment influences the output concentration of the resource, compared to the chemostat model with a single compartment of the same total volume. To this aim, we fix the hydric volumes V_1, V_2 , the input flow Q , and analyze the output map at steady state, as a function of the diffusion parameter d . Proposition 3.1.1 gives implicitly the existence of a map $d \rightarrow s_1^*(d)$ for the unique non-trivial steady-state of system (22), that we study here as a function of d . However, Proposition 3.1.1 does not give explicit ranges of existence of this steady-state, depending on the operating parameters Q and s_{in} .

Proposition 3.1.2. *Let $V = V_1 + V_2$ and define the number*

$$\bar{d} = V_2\mu(s_{in}) \frac{Q - V_1\mu(s_{in})}{Q - V\mu(s_{in})}.$$

It follows that:

- (i) *If $\mu(s_{in}) < Q/V$, then the non-trivial equilibrium $s_1^*(d) < s_{in}$ exists when $d \in (0, \bar{d})$.*
- (ii) *If $Q/V \leq \mu(s_{in}) \leq Q/V_1$, then the non-trivial equilibrium $s_1^*(d) < s_{in}$ exists when $d > 0$.*
- (iii) *If $\mu(s_{in}) > Q/V_1$, then the non-trivial equilibrium $s_1^*(d) < s_{in}$ exists when $d \geq 0$.*

Proof. When $d = 0$ (that is, when the lateral tank detached) the classical equilibrium analysis of the single chemostat model with volume V_1 (see, e.g., [32]) assures that the positive equilibrium s_1^* exists when $\mu(s_{in}) > Q/V_1$, which corresponds to the case (iii) on the proposition statement. When $d > 0$, we prove cases (i)-(iii) by taking into account that they correspond to three different scenarios where condition (27) is not fulfilled. For ease of reasoning, we rewrite $P(\mu(s_{in}))$ as

$$P(\mu(s_{in})) = V_2\mu(s_{in}) \underbrace{(V_1\mu(s_{in}) - Q)}_A + d \underbrace{(Q - (V_1 + V_2)\mu(s_{in}))}_B. \quad (33)$$

- (i). In this case, the non-trivial equilibrium exists when $P(\mu(s_{in})) < 0$. It is straightforward to see that $A < 0, B > 0$ and so $s_1^*(d) < s_{in}$ exists when $0 < d < \bar{d} = -V_2\mu(s_{in})A/B$.
- (ii). In this case, the non-trivial equilibrium exists when $P(\mu(s_{in})) < 0$. It is straightforward to see that one has $A \leq 0, B < 0$ or $A < 0, B = 0$. Then, $s_1^*(d) < s_{in}$ exists for all $d > 0$.
- (iii). In this case, the non-trivial equilibrium exists for all values of $P(\mu(s_{in}))$, and so $s_1^*(d) < s_{in}$ exists for all $d \geq 0$. \square

Let us briefly see how the two extreme situations (no diffusion and infinite diffusion) are recovered.

Lemma 3.1.2. *It follows that*

- (i) *When $\mu(s_{\text{in}}) > Q/V_1$, the non trivial equilibrium of system (22) fulfills $s_1^*(0) = s_1^{*,0}$, where $s_1^{*,0} = \mu^{-1}\left(\frac{Q}{V_1}\right)$ is the non-trivial steady state of a single chemostat model with volume V_1 . In other case $\lim_{d \rightarrow 0^+} s_1^*(d) = s_{\text{in}}$.*
- (ii) *When $\mu(s_{\text{in}}) \geq Q/V$, the non trivial equilibrium of system (22) fulfills $\lim_{d \rightarrow +\infty} s_1^*(d) = s_1^{*,\infty}$, where $s_1^{*,\infty} = \mu^{-1}\left(\frac{Q}{V}\right)$ is the non-trivial steady state of the single chemostat model with volume $V = V_1 + V_2$.*

Proof.

(i). This result is a direct consequence of the classical equilibrium analysis of the single chemostat model with volume V_1 (see, e.g., [32]), which assures that $s_1^{*,0}$ exists when $\mu(s_{\text{in}}) > Q/V_1$.

(ii). For any $d > 0$, Proposition 3.1.1 guarantees the existence of a unique non trivial equilibrium $s^* = (s_1^*, s_2^*) \in (0, s_{\text{in}}) \times (0, s_{\text{in}})$ that is solution of

$$\begin{cases} d(s_2^* - s_1^*) = (V_1\mu(s_1^*) - Q)(s_{\text{in}} - s_1^*), \\ d(s_1^* - s_2^*) = V_2\mu(s_2^*)(s_{\text{in}} - s_2^*). \end{cases} \quad (34)$$

When d is arbitrary large, one obtains

$$\lim_{d \rightarrow +\infty} s_1^* - s_2^* = 0.$$

From equations (34), one can also deduce the following equality (valid for any d)

$$(V_1\mu(s_1^*) - Q)(s_{\text{in}} - s_1^*) = -V_2\mu(s_2^*)(s_{\text{in}} - s_2^*). \quad (35)$$

Consequently, one has

$$\lim_{d \rightarrow +\infty} s_1^*(d) = \lim_{d \rightarrow +\infty} s_2^*(d) = s_{\text{in}} \text{ or } \lim_{d \rightarrow +\infty} s_1^*(d) = \lim_{d \rightarrow +\infty} s_2^*(d) = s_1^{*,\infty}$$

as $V = V_1 + V_2$, where the classical equilibrium analysis of the single chemostat model with volume V assures that $s_1^{*,\infty}$ exists when $\mu(s_{\text{in}}) > Q/V$. But Proposition 3.1.2 shows that, under the assumptions of the lemma, $s_1^*(d)$ cannot converge to s_{in} . \square

3.1.3 Optimal configurations

We first give the main properties of the map $d \rightarrow s_1^*(d)$, defined at the non-trivial steady state, and how this value is minimized.

Proposition 3.1.3. *Let \hat{s} be defined in (26) and $V = V_1 + V_2$. It follows that:*

- (i) *If $\mu(s_{\text{in}}) < Q/V$, then the map $d \rightarrow s_1^*(d)$ admits a minimum in $d^* < \bar{d}$ that is strictly less than s_{in} .*
- (ii) *If $\mu(s_{\text{in}}) \geq Q/V$ and $s_1^{*,\infty} < \hat{s}$, then the map $d \rightarrow s_1^*(d)$ admits a minimum at a certain $d^* < +\infty$, and one has $s_1^*(d) < s_1^{*,\infty}$ for any $d \geq d^*$.*
- (iii) *If $\mu(s_{\text{in}}) \geq Q/V$ and $s_1^{*,\infty} \geq \hat{s}$, then the map $d \rightarrow s_1^*(d)$ is decreasing and $s_1^*(d) > s_1^{*,\infty}$ for any $d > 0$.*

Proof. If one differentiates system (34) with respect to d , it follows that

$$(s_2^* - s_1^*) + d(\partial_d s_2^* - \partial_d s_1^*) = \partial_d s_1^* \underbrace{(Q + V_1\mu'(s_1^*)(s_{\text{in}} - s_1^*) - V_1\mu(s_1^*))}_A,$$

$$(s_1^* - s_2^*) + d(\partial_d s_1^* - \partial_d s_2^*) = \partial_d s_2^* \underbrace{(V_2 \mu'(s_2^*)(s_{in} - s_2^*) - V_2 \mu(s_2^*))}_B,$$

which can be rewritten as

$$\underbrace{\begin{bmatrix} A+d & -d \\ d & -B-d \end{bmatrix}}_{\Gamma} \begin{pmatrix} \partial_d s_1^* \\ \partial_d s_2^* \end{pmatrix} = (s_2^* - s_1^*) \begin{pmatrix} 1 \\ 1 \end{pmatrix}.$$

Remark that

$$A+d = d\phi_1'(s_1^*), \quad B+d = d\phi_2'(s_2^*), \quad \det(\Gamma) = d^2(1 - \phi_1'(s_1^*)\phi_2'(s_2^*)),$$

where ϕ_1, ϕ_2 are defined in (30), (31). Moreover $s_2^* < s_{in}$ is a zero of the concave function γ defined in (32), which verifies $\gamma(0) < 0$ and $\gamma(s_{in}) = 0$. Therefore, one has necessarily $\gamma'(s_2^*) > 0$, which amounts to write $\phi_1'(s_1^*)\phi_2'(s_2^*) > 1$ that is $\det(\Gamma) < 0$. Then, the derivatives $\partial_d s_1^*$ and $\partial_d s_2^*$ can be written as

$$\partial_d s_1^* = (s_2^* - s_1^*) \frac{-B}{\det(\Gamma)}, \quad \partial_d s_2^* = (s_2^* - s_1^*) \frac{A}{\det(\Gamma)}. \quad (36)$$

Firstly, we prove that $A > 0$ by showing that $\phi_1'(s_1^*(d)) > 1$.

From Proposition 3.1.1, one has that the positive steady-state fulfills

$$0 < s_1^*(d) < \lambda_1(s_{in}) = \min(s_{in}, s_1^{*,0}).$$

Since ϕ_1 is concave (equivalently, ϕ_1' is decreasing) on $[0, \lambda_1(s_{in})]$, one has that $\phi_1'(s_1^*(d)) > \phi_1'(\lambda_1(s_{in}))$. Thus, we prove that $A > 0$ by showing $\phi_1'(\lambda_1(s_{in})) > 1$:

- If $\mu(s_{in}) \leq Q/V_1$, then $\lambda_1(s_{in}) = s_{in}$ and $\phi_1'(s_{in}) = 1 + \frac{Q - V_1 \mu(s_{in})}{d} > 1$.

- If $\mu(s_{in}) > Q/V_1$, then $\lambda_1(s_{in}) = s_1^{*,0}$ and $\phi_1'(s_1^{*,0}) = 1 + \frac{V_1}{d} \mu'(s_1^{*,0})(s_{in} - s_1^{*,0}) > 1$.

Therefore one has $\partial_d s_2^* > 0$ i.e. $s_2^*(\cdot)$ is an increasing map.

Now, notice that $B = V_2 \beta'(s_2^*(d))$ and its sign depends on the relative position of $s_2^*(d)$ with respect to parameter \hat{s} . The cases considered on the proposition statement are treated separately.

(i) Since $s_2^*(\cdot)$ is increasing, $\lim_{d \rightarrow 0} s_2^*(d) = 0$, $\lim_{d \rightarrow \bar{d}} s_2^*(d) = s_{in}$ and $\hat{s} \in (0, s_{in})$, by using the Mean Value Theorem it follows that there exists a unique value $d \in (0, \bar{d})$ (denoted by d^*) such that $s_2^*(d^*) = \hat{s}$, with $\beta'(s_2^*(d)) > 0$ for $d < d^*$ and < 0 for $d > d^*$. Consequently, $\partial_d s_1^*$ admits a unique minimum in d^* , as $\text{sgn}(\partial_d s_1^*(d)) = -\text{sgn}(B)$.

(ii) Since $s_2^*(\cdot)$ is increasing, $\lim_{d \rightarrow 0} s_2^*(d) = 0$, $\lim_{d \rightarrow +\infty} s_2^*(d) = s_1^{*,\infty}$ and $\hat{s} \in (0, s_1^{*,\infty})$, by using the Mean Value Theorem it follows that there exists a unique value $d > 0$ (denoted by d^*) such that $s_2^*(d^*) = \hat{s}$. Consequently, $\partial_d s_1^*$ admits a unique minimum in d^* , with $s_1^*(\cdot)$ decreasing on $[0, d^*)$ and increasing on $(d^*, +\infty)$. As $s_1^*(\cdot)$ is increasing on $(d^*, +\infty)$ and $\lim_{d \rightarrow +\infty} s_1^*(d) = s_1^{*,\infty}$ (from Lemma 3.1.2), one necessarily has $s_1^*(d^*) < s_1^{*,\infty}$.

(iii) Since $s_2^*(\cdot)$ is increasing, $\lim_{d \rightarrow +\infty} s_2^*(d) = s_1^{*,\infty}$ and $\hat{s} > s_1^{*,\infty}$, one has that $\beta'(s_2^*(d)) > 0$, i.e., $s_1^*(d)$ is decreasing for any $d > 0$. As $\lim_{d \rightarrow +\infty} s_1^*(d) = s_1^{*,\infty}$, it follows that $s_1^*(d) > s_1^{*,\infty}$. \square

A schematic representation of the three possible situations can be observed in Figures 9-(a), 9-(b) and 9-(c), respectively.

Cases (a) and (b) are situations for which spatial heterogeneity is beneficial for the resource conversion, while case (c) is always less efficient than a perfectly mixed volume. Notice that (a) corresponds to inputs that lead to the wash-out of a perfectly mixed reactor of volume V , which is usually considered as an irrelevant case in the literature. However, we show here that a spatial heterogeneity could explain that, under such inputs conditions, the resource conversion is still possible.

We characterize now the optimal configurations, that are the ones minimizing the residence time or equivalently the total volume $V_1 + V_2$ for a given output concentration at steady state. We first tackle the problem when the diffusion parameter is fixed. Then, we address the full optimization problem in which the diffusion parameter is also considered as an optimization variable.

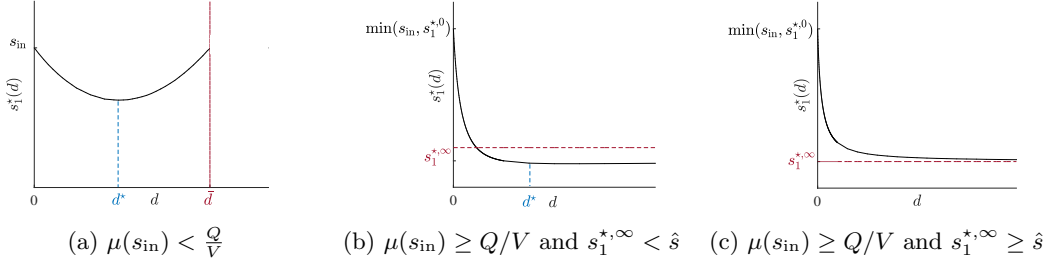

Figure 9: Plot of the function $d \rightarrow s_1^*(d)$ in the three situations depicted in Proposition 3.1.3.

Parameter d is fixed. Given a nominal desired value $s_{\text{ref}} < s_{\text{in}}$ as output of the process, we look for solutions of the optimization problem

$$\min_{(V_1, V_2) \in \mathbb{R}_+^2} \{V_1 + V_2 : \text{such that } s_1 = s_{\text{ref}} \text{ at steady state}\}, \quad (37)$$

that we denote by $(V_1^{\text{opt}}, V_2^{\text{opt}})$.

For the analysis of the solution of problem (37), it is convenient to introduce the functions

$$g(s) = \frac{1}{\beta(s)} \quad \text{and} \quad G(s) = (g(s_{\text{ref}}) - g(s))(s - s_{\text{ref}}), \quad (38)$$

defined on $(0, s_{\text{in}})$, where β is given in (25). Notice that function g admits a unique minimum at \hat{s} (by Lemma 3.1.1) and satisfies $\lim_{s \rightarrow 0} g(s) = \lim_{s \rightarrow +\infty} g(s) = +\infty$.

The solution to the optimization problem (37) is given by the following proposition.

Proposition 3.1.4. *Define*

$$\alpha = \max\left(0, s_{\text{ref}} - \frac{Q}{d}(s_{\text{in}} - s_{\text{ref}})\right).$$

The solution of problem (37) satisfies:

(i) If $\hat{s} \leq \alpha$, then $V_1^{\text{opt}} = 0$ and $V_2^{\text{opt}} = dg(\alpha)(s_{\text{ref}} - \alpha)$.

(ii) If $\hat{s} \in (\alpha, s_{\text{ref}})$, then $V_1^{\text{opt}} = Q/\mu(s_{\text{ref}}) + dg(s_{\text{ref}})(s_2^{\text{opt}} - s_{\text{ref}})$ and $V_2^{\text{opt}} = dg(s_2^{\text{opt}})(s_{\text{ref}} - s_2^{\text{opt}})$, where

$$s_2^{\text{opt}} = \begin{cases} s_G & \text{if } \alpha \in [0, s_G], \\ \alpha & \text{if } \alpha \in (s_G, \hat{s}), \end{cases}$$

s_G being the unique minimum of the function G on the interval $[\alpha, s_{\text{ref}}]$. Moreover, $G'(s_2^{\text{opt}}) > 0$ when $s_2^{\text{opt}} = \alpha$.

(iii) If $\hat{s} \geq s_{\text{ref}}$, then $V_1^{\text{opt}} = Q/\mu(s_{\text{ref}})$ and $V_2^{\text{opt}} = 0$.

Proof. We replace the value of s_1 in system (28)-(29) by s_{ref}

$$\begin{cases} 0 = \frac{Q}{V_1}(s_{\text{in}} - s_{\text{ref}}) + \frac{d}{V_1}(s_2 - s_{\text{ref}}) - \mu(s_{\text{ref}})(s_{\text{in}} - s_{\text{ref}}), \\ 0 = \frac{d}{V_2}(s_{\text{ref}} - s_2) - \mu(s_2)(s_{\text{in}} - s_2). \end{cases} \quad (39)$$

Considering function g , system (39) can be written as

$$\begin{cases} V_1 = Qg(s_{\text{ref}})(s_{\text{in}} - s_{\text{ref}}) + dg(s_{\text{ref}})(s_2 - s_{\text{ref}}) := v_1(s_2), \\ V_2 = dg(s_2)(s_{\text{ref}} - s_2) := v_2(s_2). \end{cases} \quad (40)$$

Thus, given model parameters d , Q , s_{in} and s_{ref} , the volumes are completely characterized by variable s_2 and solving the optimization problem (37) is equivalent to look for solutions of the problem

$$\min_{s_2 \in \mathcal{S}_2} v_1(s_2) + v_2(s_2), \quad (41)$$

where \mathcal{S}_2 is the set of admissible values of s_2 . That is, the solution of problem (37) is given by $(v_1(s_2^{\text{opt}}), v_2(s_2^{\text{opt}}))$, where s_2^{opt} is solution of problem (41). In order to determine the admissible set \mathcal{S}_2 , we take into account that both values V_1, V_2 must be non-negative and proceed as follows:

- a) $v_1(s_2) \geq 0 \Leftrightarrow Qg(s_{\text{ref}})(s_{\text{in}} - s_{\text{ref}}) + dg(s_{\text{ref}})(s_2 - s_{\text{ref}}) \geq 0 \Leftrightarrow s_2 \geq s_{\text{ref}} - \frac{Q}{d}(s_{\text{in}} - s_{\text{ref}})$.
- b) $v_2(s_2) \geq 0 \Leftrightarrow dg(s_2)(s_{\text{ref}} - s_2) \geq 0 \Leftrightarrow s_2 \leq s_{\text{ref}}$.

Moreover, we have to impose variable s_2 to be non-negative, since it describes a (substrate) concentration. One concludes that $\mathcal{S}_2 = [\alpha, s_{\text{ref}}]$.

For analytical purposes, we rewrite problem (41) as

$$\min_{s_2 \in [\alpha, s_{\text{ref}}]} \underbrace{Qg(s_{\text{ref}})(s_{\text{in}} - s_{\text{ref}})}_A + dG(s_2). \quad (42)$$

The term QA corresponds to the optimal volume obtained with a single tank, and with a view to reduce this value, we aim to characterize solutions of problem (42) with values of the function G being negative.

The cases considered in the proposition statement are treated separately.

- (i) $\hat{s} \leq \alpha$: Since function $g(\cdot)$ is increasing on the right of \hat{s} , then $g(s_{\text{ref}}) \geq g(s_2)$ for all $s_2 \in [\alpha, s_{\text{ref}}]$. Consequently, function G is negative on $[\alpha, s_{\text{ref}}]$ and is minimized for $s_2^{\text{opt}} = \alpha$.
- (ii) $\hat{s} \in (\alpha, s_{\text{ref}})$: In order to find s_2^{opt} on $[\alpha, s_{\text{ref}}]$ such that $G(s_2^{\text{opt}})$ is minimum, we look for critical points of G , which satisfy

$$g'(s) = H(s) := \frac{g(s_{\text{ref}}) - g(s)}{s - s_{\text{ref}}}.$$

By construction, function g' is increasing on $(0, s_{\text{in}})$, $g'(\hat{s}) = 0$ (since g is strictly convex, being equal to $1/\beta$ and β strictly concave by Lemma 3.1.1), $g'(\cdot) < 0$ on $(0, \hat{s})$ and $g'(\cdot) > 0$ on (\hat{s}, s_{in}) . Moreover, it is easy to see that the equation $H(s) = 0$ has two solutions (and not more, as g is strictly convex): s_{ref} and $\bar{s}_{\text{ref}} := \{s \in (0, \hat{s}): g(\bar{s}_{\text{ref}}) = g(s_{\text{ref}})\}$. In addition, it follows that $H(\cdot) > 0$ on $[0, \bar{s}_{\text{ref}})$ and $H(\cdot) < 0$ on $(\bar{s}_{\text{ref}}, s_{\text{ref}})$. As a result, we can state that any critical point of function G belongs to the interval $(\bar{s}_{\text{ref}}, \hat{s})$.

We show that there exist a unique critical point $s_G \in (\bar{s}_{\text{ref}}, \hat{s})$ of G by proving that function H is decreasing on this interval

$$H'(s) = \frac{-g'(s)(s - s_{\text{ref}}) - (g(s_{\text{ref}}) - g(s))}{(s - s_{\text{ref}})^2} = -\frac{g'(s) + H(s)}{s - s_{\text{ref}}} < 0.$$

Since we look for the minimum value of function G on the interval $[\alpha, s_{\text{ref}}]$, one has that s_2^{opt} depends on the value of α . A direct conclusion is that $G'(s_2^{\text{opt}}) = 0$ when $s_2^{\text{opt}} = s_G$, while $G'(s_2^{\text{opt}}) > 0$ when $s_2^{\text{opt}} = \alpha$.

- (iii) $s_{\text{ref}} \leq \hat{s}$: One has that $s_2 \leq s_{\text{ref}} \leq \hat{s}$ for all $s_2 \in [\alpha, s_{\text{ref}}]$. Since function $g(\cdot)$ is decreasing on the left of \hat{s} , then $g(s_{\text{ref}}) \leq g(s_2)$. Consequently, function G is non-negative on $[\alpha, s_{\text{ref}}]$ and the optimal value which makes it equal to zero is $s_2^{\text{opt}} = s_{\text{ref}}$.

□

Remark 3.1.1. From Proposition 3.1.4, one concludes that the particular configuration with $V_1 = 0$ (as the one depicted in Figure 8) is optimal if $\hat{s} \leq \alpha$ or if $s_G < \alpha < \hat{s} < s_{\text{ref}}$.

Characterization of the best value of the parameter d . Given a nominal desired value $s_{\text{ref}} < s_{\text{in}}$ as output of the process, we look for solutions of the optimization problem

$$\min_{(V_1, V_2, d) \in \mathbb{R}_+^3} \{V_1 + V_2 : \text{such that } s_1 = s_{\text{ref}} \text{ at steady state } \}, \quad (43)$$

that we denote by (V_1^*, V_2^*, d^*) .

Proposition 3.1.5. *The solution of problem (43) satisfies:*

(i) *If $\hat{s} < s_{\text{ref}}$, then $V_1^* = 0$, $V_2^* = Q(s_{\text{in}} - s_{\text{ref}})g(\hat{s})$ and $d^* = Q \frac{s_{\text{in}} - s_{\text{ref}}}{s_{\text{ref}} - \hat{s}}$.*

(ii) *If $\hat{s} \geq s_{\text{ref}}$, then $V_1^* = Q/\mu(s_{\text{ref}})$, $V_2^* = 0$ and d^* can take any value on the interval $[0, +\infty)$.*

Proof. In order to solve problem (43), we rely on the previous optimization results (i.e. for a given d). Thus, $(V_1^*, V_2^*, d^*) = (V_1^{\text{opt}}(d^*), V_2^{\text{opt}}(d^*), d^*)$, where d^* minimizes $V_1^{\text{opt}}(d) + V_2^{\text{opt}}(d)$ and $V_1^{\text{opt}}, V_2^{\text{opt}}$ are given by Proposition 3.1.4.

(i) From Proposition 3.1.4, one easily deduces that the total volume $V^{\text{opt}}(d) = V_1^{\text{opt}}(d) + V_2^{\text{opt}}(d)$ fulfills

$$V^{\text{opt}}(d) = \begin{cases} \frac{Q}{\mu(s_{\text{ref}})} + dG(s^{\text{opt}}(d)) & \text{if } 0 \leq d < d^* \quad (\text{case (ii) in Prop.3.1.4}), \\ Q(s_{\text{in}} - s_{\text{ref}})g(s_{\text{ref}} - \frac{Q}{d}(s_{\text{in}} - s_{\text{ref}})) & \text{if } d \geq d^* \quad (\text{case (i) in Prop.3.1.4}), \end{cases}$$

where s^{opt} must be now seen as a function of parameter d .

We analyze the monotonicity of function V^{opt} .

a) When $0 \leq d < d^*$, one has that

$$\frac{\partial V^{\text{opt}}}{\partial d} = G(s^{\text{opt}}(d)) - d \frac{\partial G}{\partial s} \Big|_{s=s^{\text{opt}}(d)} \frac{\partial s^{\text{opt}}(d)}{\partial d}.$$

From Proposition 3.1.4, it follows that $G(s^{\text{opt}}(d)) < 0$ and $s^{\text{opt}}(d)$ corresponds either to s^G (with $G'(s^G) = 0$) or to α (with $G'(\alpha) > 0$). In both cases one has $\frac{\partial V^{\text{opt}}}{\partial d} < 0$, that is, V^{opt} is decreasing on $[0, d^*)$.

b) When $d \geq d^*$, one has that

$$\frac{\partial V^{\text{opt}}}{\partial d} = \frac{Q^2}{2d^2}(s_{\text{in}} - s_{\text{ref}})^2 g'(s_{\text{ref}} - \frac{Q}{d}(s_{\text{in}} - s_{\text{ref}})).$$

By definition, \hat{s} is the only value satisfying $g'(\hat{s}) = 0$ and so d^* is the only critical point of function $V^{\text{opt}}(\cdot)$.

It remains to prove that d^* is a minimum of function $V^{\text{opt}}(d)$. But

$$\frac{\partial^2 V^{\text{opt}}}{\partial d^2}(d^*) = \frac{Q^3}{4(d^*)^4}(s_{\text{in}} - s_{\text{ref}})^3 g''(\hat{s}),$$

which is positive as g is strictly convex. Therefore V^{opt} is increasing on $[d^*, \infty)$.

From these two points we conclude that the optimal value of d is d^* .

(ii) This is a direct consequence of the statement (iii) in Proposition 3.1.4, since in this case the optimal volumes, solution of problem (37), do not depend on parameter d . \square

3.1.4 Discussion and interpretation of the results

This section is devoted to the analysis of the impact of the lateral diffusion from both ecological and engineering points of view.

From an ecological view point. In the previous section, we have investigated the yield conversion of the proposed structured chemostat and compared it with the one of a single-tank chemostat. Our main result, presented in Proposition 3.1.3 can be interpreted depending on the global removal rate $D = Q/V$ and a threshold \hat{s} (that is defined as the maximizer of the function β defined in (25)) as follows:

1. If $D > \mu(s_{\text{in}})$, a spatial distribution of the total volume V could avoid the extinction of the micro-organisms while it happens when the volume V is perfectly mixed. Therefore, the lateral-diffusive compartment plays the role of a “refuge” for the micro-organisms under large removal rates.

2. If $D \in [\mu(\hat{s}), \mu(s_{\text{in}})]$, a spatial distribution of the total volume V increases systematically the output substrate concentration with respect to that obtained if the volume V would be perfectly mixed.
3. If $D < \mu(\hat{s})$, a spatial distribution of the total volume V could reduce the output substrate concentration obtained when the volume V is perfectly mixed, but this is not systematic. This means that for small removal rates D (as often met in soil ecosystems) one cannot know if a perfectly mixed model is under- or over-estimating the expected output level of the resource.

We have also analyzed the influence of the diffusion parameter d on the yield conversion in cases 1 and 3 and shown the existence of a most efficient value d^* . The fact that a lateral-diffusive compartment is beneficial for “extreme” cases (i.e. large or small removal rates) does not appear to be an intuitive result.

From an engineering view point. In the previous section, we studied optimal choices of the main design parameters (reactor volume and diffusion rate) that minimize the residence time (or equivalently the required volume) for a given conversion rate. Our main result, presented in Propositions 3.1.4 and 3.1.5 states that, when the desired substrate output concentration is above certain threshold (more precisely, when $s_{\text{ref}} > \hat{s}$), the volume of a single-tank chemostat can be reduced by using the structure with lateral diffusion. This result complements the work in [36, 7, 10, 20, 25], where the authors propose a methodology to diminish the volume of a single-tank chemostat when $s_{\text{ref}} \leq \hat{s}$, by using either n CSTR (perfectly mixed) reactors in series or one (perfectly mixed) reactor connected in series to a “Plug Flow” Reactor”. We distinguish between the following cases:

- a) Diffusion coefficient is fixed. Depending on model parameters s_{in} , s_{ref} , Q , d and $\mu(\cdot)$, the optimal structure may be composed of two tanks (of non null volumes V_1^{opt} and V_2^{opt}) or a single lateral tank (of volume V_2^{opt}) connected by diffusion to the main stream.
- b) Diffusion coefficient can be optimized as well. The optimal structure is necessarily a single lateral tank (of volume V_2^{opt}) connected by diffusion (with optimal diffusion rate $d^* = Q \frac{s_{\text{in}} - s_{\text{ref}}}{s_{\text{ref}} - \hat{s}}$) to the main stream.

So an important message of this study is that the particular structure of a single tank connected by diffusion to a pipe that conducts the input stream, as depicted on Figure 8, can be an efficient configuration, better than a single tank directly under the main stream.

The mathematical analysis has also revealed that the function g , i.e. the inverse of the function β defined in (25), is playing an important role in determining if the best configuration is composed of one or two tanks (more precisely the relative position of the output reference value s_{ref} with respect to the minimizer \hat{s} of g). This is the same function than the one used for the optimal design of tanks in series (with also a discussion on the relative position of s_{ref} with respect to \hat{s} , see, e.g., [7, 12]), but with two main differences:

1. Due to the particular considered structure, there is a trichotomy (one single mixed tank, two tanks, or one single lateral tank) instead of the dichotomy (one or more tanks) found for the problem with tanks in series. This trichotomy is discussed below with the help of the additional parameter $\alpha = \max(0, s_{\text{ref}} - \frac{Q}{V}(s_{\text{in}} - s_{\text{ref}}))$.
2. For small values of s_{ref} (compared to \hat{s}), a lateral-diffusion compartment does not bring any improvement compared to a single perfectly mixed tank, while this is the opposite for tanks in series (i.e. several tanks are better than a single one when $s_{\text{ref}} < \hat{s}$).

These points can be grasped by the following graphical interpretation. Consider the total volume V required to obtain the output concentration s_{ref} at steady state. In our case, it can be written

in terms of the function g as follows

$$V = \underbrace{Q g(s_{\text{ref}})(s_{\text{in}} - s_{\text{ref}})}_A + \underbrace{d(g(s_{\text{ref}}) - g(s_2^*))}_{B}(s_2^* - s_{\text{ref}}) \quad (44)$$

where s_2^* is the steady state in the second compartment. One can notice that the number A is proportional to the volume necessary for a single chemostat to have s_{ref} as resource concentration at steady state. Therefore, a configuration with a lateral-diffusive compartment would require a smaller volume than that of the single chemostat exactly when the number B is negative. Figure 10 illustrates that this is possible only when s_{ref} is above the minimizer \hat{s} of the function g .

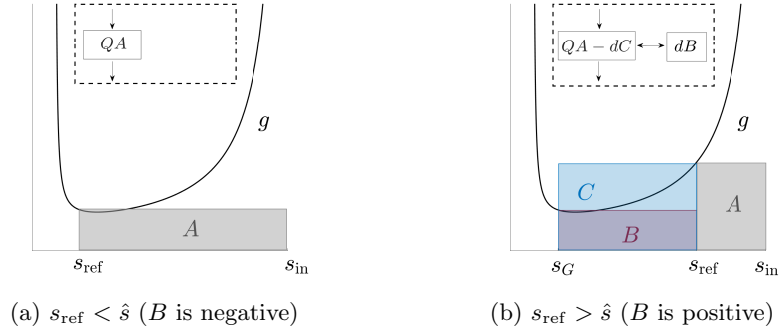

Figure 10: Graphical representation of quantities A and $|B|$ in (44).

Furthermore, the quantity B is equal to $G(s_2^*)$, where the function G defined in (38) admits an unique minimum at $s_G \in [0, s_{\text{ref}}]$. Proposition 3.1.4 states that, when $s_{\text{ref}} > \hat{s}$, the optimal value of s_2^* is s_G when $\alpha \leq s_G$ and α in other case, the later scenario corresponding to the particular configuration with $V_1 = 0$. A graphical interpretation of the optimized structures obtained when parameter d is fixed is given in Figure 11. When the diffusion rate can be chosen, the optimized configuration is as depicted in Figure 11-(c).

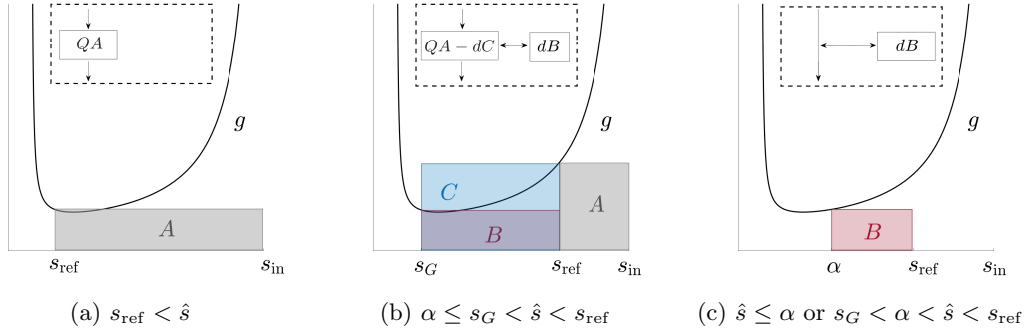

Figure 11: Graphical representation of the optimized configurations when parameter d is fixed.

Finally, let us recall from the theory of optimal design of chemostats in series that the first tank (when it is optimal to have more than one tank) has systematically a resource concentration s_1^* above \hat{s} at steady state (see, e.g., [7, 12]). Thus, for an industrial perspective, we can state that a lateral-diffusive compartment for the first tank of an optimal series of chemostat could systematically improve the performance of the overall process.

3.2 Which of serial or parallel interconnection is better?

This section has been inspired by [9].

The aim of this section is to identify conditions, when a flow rate Q and a total hydric volume V are given, which among the best serial or parallel configurations has the best conversion rate, playing with the distribution parameter between the volumes $r = V_1/V$ (where $V = V_1 + V_2$), the flow distribution α and the diffusion coefficient d for the parallel case.

For sake of simplicity of the analytical analysis, we assume that the growth function $\mu(\cdot)$ is a linear function of the resource concentration:

$$\mu(S) = mS$$

However, all the results hold true for any increasing growth functions, although expressions are more complex. As usual, the yield coefficient y of the bio-conversion can be kept equal to one (we recall that this is always possible by choosing the unit measuring the biomass). In view of comparing configurations, it is convenient to write dimensionless concentrations: for each concentration C_i in the compartment i (C_i can denote S_i or X_i), we posit

$$c_i = m \frac{V}{Q} C_i \quad \text{and} \quad r_i = \frac{V_i}{V}.$$

We shall also consider that the time t is measured in units such that $Q = V$. For this analysis, we assume that the input concentration S_{in} is large enough to avoid the (trivial) wash-out equilibrium to be the only steady-state in each compartment, so that we do not have to deal with "degenerate" case.

3.2.1 The single compartment model

We consider the single tank model as the "reference" model, whose dynamical equations are

$$\begin{cases} \dot{s} &= -sx + s_{in} - s \\ \dot{x} &= sx - x \end{cases}$$

The non-trivial equilibrium is $(1, s_{in} - 1)$ under the condition $s_{in} > 1$. Then, one has $s_{out}^* = 1$ (and its globally asymptotic convergence on the positive domain is guaranteed by Proposition 2.3). Therefore, any other configuration is better than the single tank one when its output concentration at steady state s_{out}^* is below 1.

Remark 3.2.1. *This is a well known property from the theory of the chemostat that the output concentration at steady state is independent of the input concentration, provided this latter to be large enough (i.e. $s_{in} \geq 1$).*

3.2.2 The serial configuration

We consider the serial configuration (see Fig. 6a), whose dynamical equations are

$$\begin{cases} \dot{s}_1 &= -s_1 x_1 + \frac{1}{r}(s_{in} - s_1) \\ \dot{x}_1 &= s_1 x_1 - \frac{1}{r} x_1 \\ \dot{s}_2 &= -s_2 x_2 + \frac{1}{1-r}(s_1 - s_2) \\ \dot{x}_2 &= s_2 x_2 + \frac{1}{1-r}(x_1 - x_2) \end{cases} \quad (45)$$

where r is different to 0 and 1.

Proposition 3.2.1. *When $s_{in} > 1/r$, there exists a unique equilibrium $(s_1^*, x_1^*, s_2^*, x_2^*)$ of (45) on the positive orthant. One has necessarily $s_1^* = 1/r$ and $s_2^* < \min(1/r, 1/(1-r))$. Furthermore, one has*

$$s_{out}^* < 1 \iff s_{in} > 1 + 1/r . \quad (46)$$

Proof. One can readily check that there exists a non-trivial equilibrium $(1/r, s_{in} - 1/r)$ for the first compartment exactly when $s_{in} > 1/r$. Furthermore, this equilibrium is unique. Then, any equilibrium for the overall system (45) has to be $(s_2^*, s_{in} - s_2^*)$ for the second compartment, with s_2^* solution of the equation

$$s_2(s_{in} - s_2) = \frac{1}{1-r}(1/r - s_2) \quad (47)$$

with $s_2^* < 1/r$. One can easily verify that there exists a unique s_2^* solution of (47) on $(0, 1/r)$. Graphically, s_2^* is the abscissa of the intersection of the graphs (see Figure 12) of the polynomial function

$$\phi(s_2) = s_2(s_{in} - s_2)$$

and the affine function

$$l(s_2) = \frac{1}{1-r}(1/r - s_2) .$$

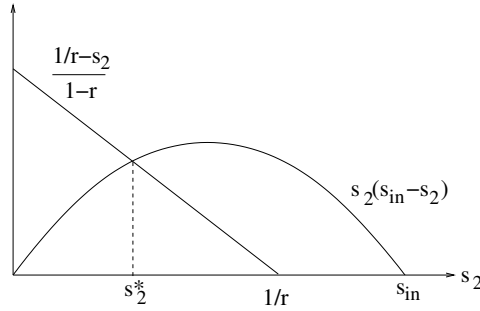

Figure 12: Graphical determination of s_2^* .

Remark that $s_{in} > 1/r$ implies the inequality $\phi(1/(1-r)) > l(1/(1-r))$, from which one deduces $s_2^* < 1/(1-r)$. Finally one can compare $s_{out} = s_2^*$ with the value obtained in the configuration of one compartment:

$$s_{out}^* < 1 \iff \phi(1) > l(1) \iff s_{in} > 1 + 1/r .$$

□

Remark 3.2.2. *The global stability of the non-trivial equilibrium is guaranteed by Proposition 2.3, as one $\mu(s_{in}) > Q/V_1$ and $\mu(s_{in}) > Q/V_2$.*

Equivalence (46) implies the existence a threshold $\bar{s}_{in} = 2$ such that for any $s_{in} \leq \bar{s}_{in}$, and serial distribution of the volumes has a worse conversion rate than the single tank case. On the opposite, for $s_{in} > \bar{s}_{in}$, there exists a distribution of the volumes that produces a better conversion rate. As an illustration, the graph of the function s_{out}^* is plotted as function of $r \in [1/s_{in}, 1]$ on Figure 13 for different values of the input concentration s_{in} .

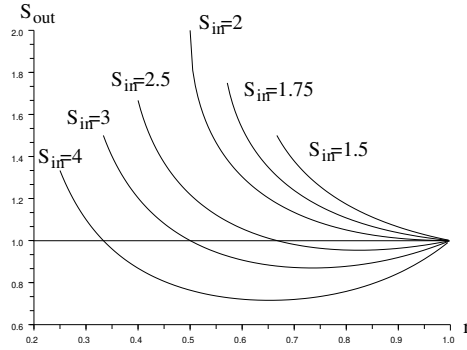

Figure 13: Comparison of s_{out}^* for the serial configuration.

3.2.3 The parallel configuration

The dynamical equations of the model with two compartments in parallel with diffusion, depicted on Figure 6b) are

$$\begin{cases} \dot{s}_1 &= -s_1x_1 + \frac{\alpha}{r}(s_{in} - s_1) + \frac{d}{r}(s_2 - s_1) \\ \dot{x}_1 &= s_1x_1 - \frac{\alpha}{r}x_1 + \frac{d}{r}(x_2 - x_1) \\ \dot{s}_2 &= -s_2x_2 + \frac{1-\alpha}{1-r}(s_{in} - s_2) + \frac{d}{1-r}(s_1 - s_2) \\ \dot{x}_2 &= s_2x_2 - \frac{1-\alpha}{1-r}x_2 + \frac{d}{1-r}(x_1 - x_2) \end{cases} \quad (48)$$

where r is different to 0 and 1, with the output concentration given by

$$s_{out} = \alpha s_1 + (1 - \alpha)s_2 .$$

For convenience, we posit

$$\alpha_1 = \frac{\alpha}{r} , \alpha_2 = \frac{1 - \alpha}{1 - r} ,$$

and assume, without any loss of generality that one has $\alpha_2 \geq \alpha_1$ (if it is not the case one can just exchange indexes 1 and 2). Notice that one has necessarily $\alpha_2 \geq 1$ and $\alpha_1 \leq 1$.

The conditions of Proposition 2.3 to ensure the existence of a positive steady-state are here $\mu(s_{in}) > \alpha_1 + d/r$ and $\mu(s_{in}) > \alpha_2 + d/(1-r)$. However, we show that the existence of a positive steady-state can be obtained even when these conditions are not satisfied.

When $d = 0$ (no diffusion), the equilibrium of the system can be determined independently in the two compartments as simple chemostat models. In this case, there is an unique globally stable equilibrium $(s_1^*, s_{in} - s_1^*, s_2^*, s_{in} - s_2^*)$ in the non-negative orthant, where $s_i^* = \min(\alpha_i, s_{in})$ ($i = 1, 2$).

When $d > 0$, we define the functions

$$\begin{aligned} \phi_2(s_1) &= s_1 + \frac{r}{d}(s_{in} - s_1)(s_1 - \alpha_1) , \\ \phi_1(s_2) &= s_2 + \frac{1-r}{d}(s_{in} - s_2)(s_2 - \alpha_2) , \end{aligned}$$

and

$$g(s_1) = \phi_1(\phi_2(s_1)) - s_1 .$$

Proposition 3.2.2. When $s_{in} > 1$ and $d > 0$, there exists a unique equilibrium $(s_1^*, x_1^*, s_2^*, x_2^*)$ of (48) in the positive orthant, where (s_1^*, s_2^*) is the unique solution of the system

$$s_2^* = \phi_2(s_1^*) \text{ and } s_1^* = \phi_1(s_2^*), \quad (49)$$

on the domain $(0, s_{in}) \times (0, s_{in})$, with $x_i^* = s_{in} - s_i^*$ ($i = 1, 2$). Furthermore, $s_1^* = s_2^* = 1$ when $\alpha_2 = \alpha_1$ and

$$\alpha_1 < s_1^* < s_2^* < \min(\alpha_2, s_{in}) \quad (50)$$

when $\alpha_2 > \alpha_1$.

Proof. At equilibrium, one has

$$\begin{aligned} r(\dot{s}_1 + \dot{x}_1) + (1-r)(\dot{s}_2 + \dot{x}_2) &= 0, \\ r(\dot{s}_1 + \dot{x}_1) &= 0, \end{aligned}$$

which amounts to write, from equations (48)

$$\begin{aligned} \alpha(s_{in} - s_1^* - x_1^*) + (1-\alpha)(s_{in} - s_2^* - x_2^*) &= 0, \\ \alpha(s_{in} - s_1^* - x_1^*) + d(s_2^* + x_2^* - s_1^* - x_1^*) &= 0, \end{aligned}$$

or equivalently

$$\underbrace{\begin{bmatrix} \alpha & 1-\alpha \\ \alpha+d & -d \end{bmatrix}}_M \begin{pmatrix} s_{in} - s_1^* - x_1^* \\ s_{in} - s_2^* - x_2^* \end{pmatrix} = \begin{pmatrix} 0 \\ 0 \end{pmatrix}$$

One has $\det(M) = \alpha^2 - \alpha - d \leq -d < 0$ and deduces the property

$$s_1^* + x_1^* = s_2^* + x_2^* = s_{in}.$$

Consequently, an equilibrium in the positive orthant has to fulfill $s_i^* \in [0, s_{in}]$ for $i = 1, 2$. Replacing x_i^* by $s_{in} - s_i^*$ in equations (48) at equilibrium, one obtains the equations

$$\begin{aligned} d(s_2^* - s_1^*) &= r(s_{in} - s_1^*)(s_1^* - \alpha_1) \\ d(s_1^* - s_2^*) &= (1-r)(s_{in} - s_2^*)(s_2^* - \alpha_2) \end{aligned} \quad (51)$$

which amounts to write that (s_1^*, s_2^*) is solution of the system (49) (see Figure 14) or equivalently s_1^* is a zero of the function $g(\cdot)$.

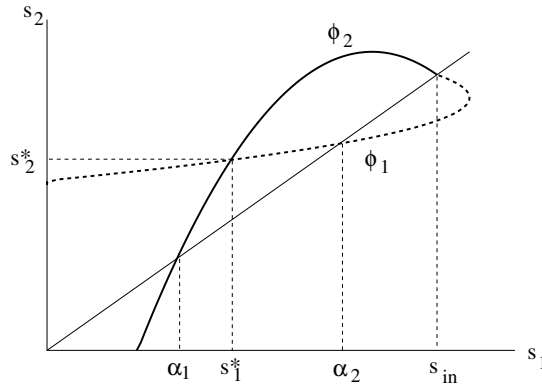

Figure 14: Graphical determination of the steady states (when $\alpha_1 < \alpha_2 < s_{in}$).

When $\alpha_2 = \alpha_1 = 1$, one can check that $s_1^* = s_2^* = 1 < s_{in}$ is solution of (49). When $\alpha_2 > \alpha_1$, one has necessarily $\alpha_1 < 1$ and the condition $s_{in} > 1$ implies $g(\alpha_1) < 0$. We distinguish now two cases:

Case $\alpha_2 < s_{in}$. If $\phi_2(\alpha_2) \leq s_{in}$, notice that one has $\phi_2(\alpha_2) > \alpha_2$ and then $g(\alpha_2) > 0$. If $\phi_2(\alpha_2) > s_{in}$, notice that $\phi_2(\alpha_1) = \alpha_1 < s_{in}$ and by the Mean Value Theorem, there exists $\tilde{s}_2 \in (\alpha_1, \alpha_2)$ such that $\phi_2(\tilde{s}_2) = s_{in}$ which implies $g(\tilde{s}_2) = s_{in} - \tilde{s}_2 > 0$. In both cases, one deduces by the Mean Value Theorem the existence of $s_1^* \in (\alpha_1, \alpha_2)$ such that $g(s_1^*) = 0$.

Case $\alpha_2 \geq s_{in}$. One has $g(s_{in}) = 0$ with

$$g'(s_{in}) = \frac{r(1-r)}{d^2}(\alpha_1 - s_{in})(\alpha_2 - s_{in}) + \frac{1-s_{in}}{d} < 0.$$

Rolle and Mean Value Theorems allow to conclude the existence of $s_1^* \in (\alpha_1, s_{in})$ such that $g(s_1^*) = 0$.

In any case, we obtain the existence of (s_1^*, s_2^*) solution of (49) with s_1^* belonging to the interval $(\alpha_1, \min(\alpha_2, s_{in}))$, that implies $s_2^* = \phi_2(s_1^*) > s_1^*$. But then $s_1^* = \phi_1(s_2^*) < s_2^*$ implies $s_2^* < \min(\alpha_2, s_{in})$. Thus, the inequalities (50) are fulfilled.

Finally, notice that functions $\phi_1(\cdot)$, $\phi_2(\cdot)$ are both strictly concave, and steady states (s_1^*, s_2^*) are intersections of \mathcal{G}_1 , the graph of the function $\phi_1(\cdot)$, and \mathcal{G}_2 the symmetric of the graph of $\phi_2(\cdot)$ with respect to the first diagonal. Consequently, if (s_1^*, s_2^*) is a steady state different from (s_{in}, s_{in}) , \mathcal{G}_1 and \mathcal{G}_2 are respectively above and below the line segment $(s_1^*, s_2^*) - (s_{in}, s_{in})$. We conclude that there exists at most one non-trivial equilibrium. \square

Corollary 3.2.1. *When $s_{in} > 1$ and $d > 0$, the value s_1^* of the non trivial equilibrium is the unique zero of the function $g(\cdot)$ on $(\alpha_1, \min(\alpha_2, s_{in}))$. Furthermore, one has $g'(s_1^*) > 0$.*

Proof. When $\alpha_1 = \alpha_2$, one has $s_1^* = s_2^* = 1$ and one can easily check

$$g'(s_1^*) = \left(1 + \frac{r}{d}(s_{in} - 1)\right) \left(1 + \frac{1-r}{d}(s_{in} - 1)\right) - 1 > 0.$$

When $\alpha_2 > \alpha_1$, one has $g(\alpha_1) < 0$ and we recall from the proof of Proposition 3.2.1 that s_1^* is the unique zero of $g(\cdot)$ on $(\alpha_1, \min(\alpha_2, s_{in}))$. We conclude that g is non decreasing at s_1^* . Notice that ϕ_1 and ϕ_2 are concave functions and that

$$\phi_1'(\phi_2(s_1^*)) = 1 + \frac{1-r}{d}(s_{in} + \alpha_2 - 2s_2^*) > 0$$

implies

$$g''(s_1^*) = \phi_1''(\phi_2(s_1^*)) \cdot [\phi_2'(s_1^*)]^2 + \phi_1'(\phi_2(s_1^*)) \cdot \phi_2''(s_1^*) < 0$$

We deduce that $g'(s_1^*)$ cannot be equal to zero (because g changes its sign at s_1^*), and consequently one has $g'(s_1^*) > 0$. \square

Proposition 3.2.2 defines properly the map $d \mapsto s_{out}^* = \alpha s_1^* + (1-\alpha)s_2^*$ for the unique non-trivial steady-state, that we aim at studying as a function of d . Accordingly to Proposition 3.2.2, s_{out}^* is equal to one for any value of the parameter d in the non-generic case $\alpha_2 = \alpha_1$. We shall focus on the case $\alpha_2 \neq \alpha_1$ (and without loss of generality we shall consider $\alpha_2 > \alpha_1$). We start by the two extreme situations: no diffusion and infinite diffusion.

Lemma 3.2.1. *For the non trivial equilibrium, one has*

$$s_{out}^*(0) \geq 1 \iff s_{in} \geq s_{in}^0 = \frac{r - \alpha^2}{r(1 - \alpha)}$$

with $s_{in}^0 \in (1, 2)$.

Proof. Under the assumptions $s_{in} > 1$ and $\alpha_2 \geq \alpha_1$, we distinguish two cases when $d = 0$. If $s_{in} \geq \alpha_2$, one has $s_1^* = \alpha_1$ and $s_2^* = \alpha_2$. Then, one can write

$$s_{out}^* = \frac{\alpha^2}{r} + \frac{(1-\alpha)^2}{1-r} = 1 + \frac{(\alpha-r)^2}{r(1-r)} \geq 1.$$

If $s_{in} < \alpha_2$, one has $s_1^* = \alpha_1$, $s_2^* = s_{in}$ and

$$s_{out}^* \geq 1 \iff s_{in} \geq \frac{1 - \alpha\alpha_1}{1 - \alpha} = s_{in}^0 .$$

(recall that assuming $\alpha_2 \geq \alpha_1$ imposes to have $\alpha < 1$, and s_{in}^0 is well defined). Notice that the number s_{in}^0 is necessarily larger than one because $\alpha_1 \leq 1$, and one has also

$$\alpha_2 - s_{in}^0 = \frac{(r - \alpha)^2}{r(1 - r)(1 - \alpha)} \geq 0 .$$

Consequently one concludes that $s_{out}^* \geq 1$ exactly when $s_{in} \geq s_{in}^0$. Finally, remark that one has

$$s_{in}^0 = \frac{r - \alpha^2}{r(1 - \alpha)} = 1 - \frac{(\alpha - r)^2}{r(r - \alpha)} + \frac{r - \alpha}{1 - \alpha} < 2 .$$

□

Lemma 3.2.2. *For $s_{in} > 1$, the non trivial equilibrium fulfill*

$$\lim_{d \rightarrow +\infty} s_1^*(d) = \lim_{d \rightarrow +\infty} s_2^*(d) = \lim_{d \rightarrow +\infty} s_{out}^*(d) = 1 .$$

Proof. For any $d > 0$, Proposition 3.2.2 guarantees the existence of a unique non trivial equilibrium $(s_1^*, s_2^*) \in (0, s_{in}) \times (0, s_{in})$ that is solution of (51). When d is arbitrary large, one obtains from (51)

$$\lim_{d \rightarrow +\infty} s_1^*(d) - s_2^*(d) = 0 .$$

From equations (51), one deduces also the following equality valid for any d

$$r(s_{in} - s_1^*)(s_1^* - \alpha_1) + (1 - r)(s_{in} - s_2^*)(s_2^* - \alpha_2) = 0 ,$$

that can be rewritten, taking into account the equality $r\alpha_1 + (1 - r)\alpha_2 = 1$:

$$(s_{in} - s_1^*)(s_1^* - 1) = (1 - r)(s_1^* - s_2^*)(s_{in} + \alpha_2 - s_1^* - s_2^*) .$$

Consequently, one has

$$\lim_{d \rightarrow +\infty} s_1^*(d) = \lim_{d \rightarrow +\infty} s_2^*(d) = 1 \text{ or } \lim_{d \rightarrow +\infty} s_1^*(d) = \lim_{d \rightarrow +\infty} s_2^*(d) = s_{in} .$$

If $\alpha_2 < s_{in}$, the property $s_1^* < \alpha_2$ valid for any $d > 0$ implies that s_1^* cannot converge to s_{in} . If $\alpha_2 \geq s_{in}$ and $\lim s_1^* = \lim s_2^* = s_{in}$, there exists d such that $rs_1^* + (1 - r)s_2^* > (s_{in} + 1)/2$. Then, one has

$$g'(s_1^*) = \frac{r(1 - r)}{d^2}(s_{in} + \alpha_1 - 2s_1^*)(s_{in} + \alpha_2 - 2s_2^*) + \frac{s_{in} + 1 - 2(rs_1^* + (1 - r)s_2^*)}{d} < 0$$

that contradicts Corollary 3.2.1. Finally, one has $\lim s_1^* = \lim s_2^* = 1$ and consequently $\lim s_{out}^* = 1$.

□

We present now the main result concerning properties of the map $d \mapsto s_{out}^*(d)$ defined at the non-trivial steady-state.

Proposition 3.2.3. *Assume $\alpha_2 > \alpha_1$.*

- *When $s_{in} \geq 2$, the map $d \mapsto s_{out}^*(d)$ (for the non trivial equilibrium) is decreasing and $s_{out}^*(d) > 1$ for any $d \geq 0$.*

- When $s_{in} < 2$, the map $d \mapsto s_{out}^*(d)$ (for the non trivial equilibrium) admits a minimum in $d^* < +\infty$, that is strictly less than one. Furthermore, one has

$$s_{in} > \underline{s}_{in} = \frac{2\alpha_1\alpha_2}{\alpha_1 + \alpha_2} \implies d^* > 0$$

with $\underline{s}_{in} < \min(2, \alpha_2)$.

Proof. Let differentiate with respect to d the equations (51) at steady state:

$$\begin{aligned} (s_2^* - s_1^*) + d(\partial_d s_2^* - \partial_d s_1^*) &= \underbrace{r(s_{in} - 2s_1^* + \alpha_1)}_A \partial_d s_1^* \\ (s_1^* - s_2^*) + d(\partial_d s_1^* - \partial_d s_2^*) &= \underbrace{(1-r)(s_{in} - 2s_2^* + \alpha_2)}_B \partial_d s_2^* \end{aligned}$$

that can be rewritten as follows

$$\underbrace{\begin{bmatrix} A+d & -d \\ d & -B-d \end{bmatrix}}_{\Gamma} \begin{pmatrix} \partial_d s_1^* \\ \partial_d s_2^* \end{pmatrix} = (s_2^* - s_1^*) \begin{pmatrix} 1 \\ 1 \end{pmatrix}$$

Remark that one has

$$\begin{aligned} A+d &= d\phi_2'(s_1^*) \\ B+d &= d\phi_1'(s_2^*) \\ \det(\Gamma) &= d^2(1 - \phi_1'(s_2^*)\phi_2'(s_1^*)) = -d^2g'(s_1^*) \end{aligned}$$

From Corollary 3.2.1, one has $\det(\Gamma) < 0$ and one deduces that the derivatives $\partial_d s_1^*$, $\partial_d s_2^*$ are defined as follows

$$\begin{aligned} \partial_d s_1^* &= (s_2^* - s_1^*) \frac{-B}{\det(\Gamma)} \\ \partial_d s_2^* &= (s_2^* - s_1^*) \frac{A}{\det(\Gamma)} \end{aligned} \tag{52}$$

Notice from inequalities (50) that we obtain $B > 0$ and deduce $\partial_d s_1^* > 0$ for any d . With Lemma 3.2.2 we conclude that $s_1^*(d) < 1$ for any d .

From equations (52), we can write

$$\partial_d s_{out}^* = (s_2^* - s_1^*) \frac{\alpha B - (1-\alpha)A}{-\det(\Gamma)} = \underbrace{[\alpha_1(s_{in} - 2s_2^*) - \alpha_2(s_{in} - 2s_1^*)]}_{\sigma} \frac{d(s_2^* - s_1^*)r(1-r)}{-\det(\Gamma)}$$

When $s_{in} \geq 2$, one has $A > 0$ and then $\partial_d s_2^* < 0$. With Lemma 3.2.2 we conclude that $s_2^*(d) > 1$ for any d . Then, one obtains the inequality

$$\sigma < (s_{in} - 2)(\alpha_1 - \alpha_2) \leq 0$$

which proves with Lemma 3.2.2 that s_{out}^* is a decreasing function of d that converges to one.

When $s_{in} < 2$, we write

$$\sigma = (s_{in} - 2)(\alpha_1 - \alpha_2) + 2(\alpha_1(1 - s_2^*) - \alpha_2(1 - s_1^*))$$

As s_1^* and s_2^* tend to one when d takes arbitrary large values, we conclude that there exists $\bar{d} < +\infty$ such that $\sigma > 0$ for any $d > \bar{d}$ and consequently s_{out}^* is smaller than one and increasing for $d > \bar{d}$. We conclude that the map $d \mapsto s_{out}^*(d)$ admits a minimum, say at $d^* < +\infty$, that is strictly less than one.

When $d = 0$, one has $s_1^* = \alpha_1$ and $s_2^* = \alpha_2$ if $s_{in} \geq \alpha_2$. Then, one obtains $\sigma = s_{in}(\alpha_1 - \alpha_2) < 0$. So the map $d \mapsto \partial_d s_{out}^*(d)$ is decreasing at $d = 0$ and consequently $d^* > 0$.

When $d = 0$ with $s_{in} < \alpha_2$, one has $s_2^* = s_{in}$ and then $\sigma = 2\alpha_1\alpha_2 - s_{in}(\alpha_1 + \alpha_2)$, for which we conclude

$$\sigma < 0 \iff s_{in} > \frac{2\alpha_1\alpha_2}{\alpha_1 + \alpha_2} = \underline{s}_{in} .$$

Notice that this case is feasible because of the inequality $2\alpha_1\alpha_2 < \min(2, \alpha_2)(\alpha_1 + \alpha_2)$. We conclude that for s_{in} larger than this last value, d^* is necessarily strictly positive. \square

As mentioned previously, Proposition 2.3 cannot allow to conclude about the global stability of the positive equilibrium in any case. A complete proof is given in Appendix A.5.

Remark 3.2.3. We obtain the same threshold $\bar{s}_{in} = 2$ than the one obtained for the serial configuration (cf Section 3.2.2) on the value of s_{in} which discriminates situations for which it is possible to be better than the single tank configuration or not (bt here the condition is reversed).

For the parallel interconnection, we depict on Figure 15 the two kind of configurations that occur, depending on whether the number \underline{s}_{in} is larger than one or not.

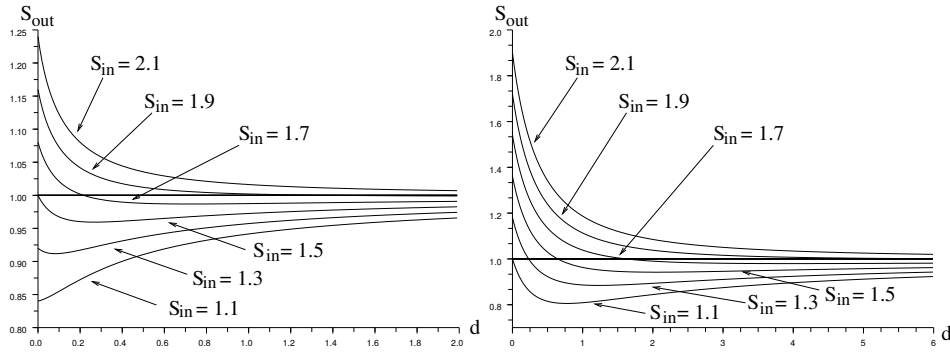

Figure 15: Comparison of s_{out}^* for the parallel configuration ($\underline{s}_{in} > 1$ on the left and $\underline{s}_{in} < 1$ on the right) .

3.2.4 Conclusions

Given a flow rate and the total volume of a chemostat-like system, this study reveals the existence of a threshold \bar{s}_{in} on the value of the input concentration s_{in} such that above and below this threshold, serial and the parallel configurations are respectively the best ones with respect to the criterion of minimizing the output concentration s_{out}^* at steady state. Moreover, for the parallel scheme, the best performances are obtained for a precise value of the diffusion parameter that is proved to be positive when s_{in} is not too small (i.e. above another threshold $\underline{s}_{in} < \bar{s}_{in}$).

These results show that a single perfectly mixed vessel (when it does not lead toward the wash-out of the biomass) can be advantageously replaced by a configuration of two tanks with the same total volume (serial or parallel, depending on the value of the input concentration) that provides a better conversion rate of the substrate at steady state, for the same total volume (or equivalently the same total residence time).

Finally, this study reveals the role of the spatial structure on the performances of simple ecosystems or bio-processes, and can be of interest for reverse engineering for deciding which among serial or parallel configurations is better fit for the modeling of biochemical systems, providing that one has already an estimation of the hydric capacity of the system, as depicted on Fig.16.

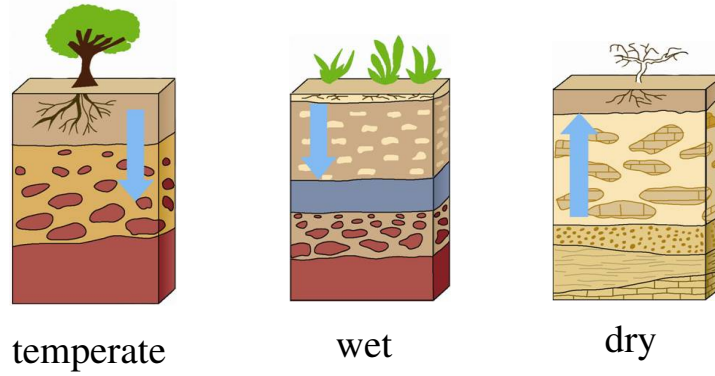

Figure 16: The microbial activity of a soil in temperate or humid climate is expected to better represented by a serial configuration, while parallel scheme may better suits shallow grounds in dry climate.

3.3 Vessel with a buffer compartment

This section has been inspired by [26].

In this section we consider configurations as depicted on Fig. 6c) but with a slightly different objective than from the previous sections: the growth function μ is here non-monotonic (for which the results exposed in Section 2 do not apply).

3.3.1 Consideration of growth inhibition

Let us first recall the properties of the model with a single tank:

$$\begin{cases} \dot{S} &= -\mu(S)X + \frac{Q}{V}(S_{in} - S) , \\ \dot{X} &= \mu(S)X - \frac{Q}{V}X , \end{cases} \quad (53)$$

(where the yield coefficient has been kept equal to 1 without loss of generality), where μ belongs to the following class of uptake functions.

Hypothesis H2c. The function $\mu(\cdot)$ is analytic and such that

- (i) $\mu(0) = 0$, $\mu(S) > 0$ for any $S > 0$,
- (ii) there exists $\hat{S} > 0$ such that $\mu(\cdot)$ is increasing on $(0, \hat{S})$ and decreasing on $(\hat{S}, +\infty)$.

A typical instance of such functions is the Haldane one [1]

$$\mu(S) = \frac{\bar{\mu}S}{K + S + S^2/K_I} , \quad (54)$$

For convenience, we denote the dilution rate

$$D = \frac{Q}{V} .$$

and consider classically the "growth" set (see Fig. 17 for the Haldane function)

$$\Lambda(D) = \{S > 0 \mid \mu(S) > D\} . \quad (55)$$

Under Hypothesis H2c, the set $\Lambda(D)$ is either empty or an open interval that we denote

$$\Lambda(D) = (\lambda_-(D), \lambda_+(D))$$

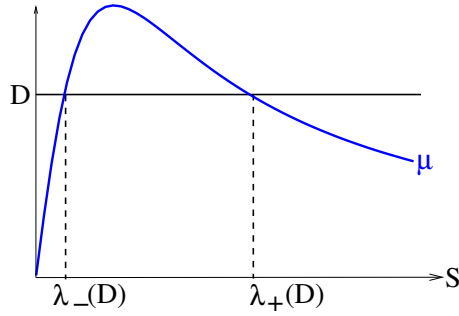

Figure 17: The set $\Lambda(D) = (\lambda_-(D), \lambda_+(D))$ for the Haldane growth function.

(where $\lambda_+(D)$ could be $+\infty$). We recall from the classical theory of the chemostat model (see for instance [32, 11]) that under Hypothesis H2c there are three kinds of asymptotic behaviors of the dynamics (53), depending on the parameter S_{in} .

Proposition 3.3.1. *Under Hypothesis H2c, one of the following cases occur.*

(case 1) $\Lambda(D) = \emptyset$ or $\lambda_-(D) \geq S_{in}$. The washout equilibrium $E_0 = (S_{in}, 0)$ is the unique non negative equilibrium of system (53). Furthermore it is globally attracting.

(case 2) $S_{in} > \lambda_+(D)$. The system (53) has two positive equilibria $E_-(D) = (\lambda_-(D), S_{in} - \lambda_-(D))$, $E_+(D) = (\lambda_+(D), S_{in} - \lambda_+(D))$ in addition to the washout equilibrium $E_0 = (S_{in}, 0)$. Only $E_-(D)$ and E_0 are attracting, and the dynamics is bi-stable.

(case 3) $S_{in} \in \Lambda(D)$. The system (53) has one positive equilibrium $E_-(D) = (\lambda_-(D), S_{in} - \lambda_-(D))$ and the washout equilibrium $E_0 = (S_{in}, 0)$. $E_-(D)$ is globally attracting on the positive quadrant.

In this rest of the section, we consider that the case 2, which exhibits instability, occurs. Then the asymptotic behavior of the system (wash-out or not) depends on which attraction basin the initial condition belongs to. The question we investigate is related to the assumption that the vessel is perfectly mixed, and to the role that a spatial structure could have on the stability of the dynamics. Let us fix the total volume V , the input flow rate Q and the input concentration S_{in} so that one has $S_{in} > \lambda_+(D)$. Consider a serial structure, as depicted on Fig. 6a, with $V_1 + V_2 = V$. The dynamics of the first tank of volume V_1 is given by the same equations (53) where V is replaced by $V_1 \leq V$. Its dilution rate is then equal to Q/V_1 , which is greater than $D = Q/V$ and consequently one has $S_{in} \notin \Lambda(Q/V_1)$. According to Proposition 3.3.1, Case 2 occurs in the first tank i.e. the positive equilibrium $E_-(Q/V_1)$ and the wash-out E_0 are both attractive equilibria. When the first tank is conducted to the wash-out, then the system behaves asymptotically as a single tank of volume V_2 with input concentration S_{in} for the substrate and 0 and no biomass at input. Proposition 3.3.1 applies again and the wash-out in both tanks is necessarily an attractive equilibrium, whatever is the volume distribution. However, we shall show see that it is possible to fix the flow distribution α as depicted on Fig. 6c) so that the whole system admits a unique positive equilibrium that is globally asymptotically stable on the positive orthant.

The model equations of the two tanks models with the second have as a "buffer" (Fig. 6c)

$$\begin{cases} \dot{S}_1 &= -\mu(S_1)X_1 + \frac{Q}{V_1}(\alpha S_{in} + (1-\alpha)S_2 - S_1), \\ \dot{X}_1 &= \mu(S_1)X_1 + \frac{Q}{V_1}((1-\alpha)X_2 - X_1), \\ \dot{S}_2 &= -\mu(S_2)X_2 + \frac{Q(1-\alpha)}{V_2}(S_{in} - S_2), \\ \dot{X}_2 &= \mu(S_2)X_2 - \frac{Q(1-\alpha)}{V_2}X_2. \end{cases} \quad (56)$$

(keeping again the yield coefficient equal to 1 without loss of generality). It is convenient to parameterize the system with

$$r = \frac{V_1}{V} \in (0, 1), \quad \rho = \frac{(1 - \alpha)}{(1 - r)} > 0 .$$

which allows to rewrite the system as follows

$$\begin{cases} \dot{S}_1 &= -\mu(S_1)X_1 + D \frac{\rho(1-r)(S_2 - S_1) + (1 - \rho(1-r))(S_{in} - S_1)}{r} , \\ \dot{X}_1 &= \mu(S_1)X_1 + D \frac{\rho(1-r)(X_2 - X_1) - (1 - \rho(1-r))X_1}{r} , \\ \dot{S}_2 &= -\mu(S_2)X_2 + \rho D(S_{in} - S_2) , \\ \dot{X}_2 &= \mu(S_2)X_2 - \rho D X_2 . \end{cases} \quad (57)$$

Then, the condition $S_{in} > \lambda_+(D)$ amounts to have

$$\mu(S_{in}) < D \quad (58)$$

An equilibrium $(S_1^*, X_1^*, S_2^*, X_2^*)$ of dynamics (57) is solution of the following equations:

$$1 + \frac{1-r}{r} \left(1 - \rho \frac{S_{in} - S_2^*}{S_{in} - S_1^*} \right) = \frac{\mu(S_1^*)}{D} \text{ or } \{S_1^* = S_{in} \text{ when } S_2^* = S_{in}\} \quad (59)$$

$$X_1^* = S_{in} - S_1^* \quad (60)$$

$$\rho = \frac{\mu(S_2^*)}{D} \text{ or } S_2^* = S_{in} \quad (61)$$

$$X_2^* = S_{in} - S_2^* \quad (62)$$

Notice that the dynamics of the second vessel can be studied independently to the first one fixing only the parameter ρ . To obtain a global stability in this tank we have then to choose $\rho < \mu(s_{in})/D$ accordingly to Proposition 3.3.1. Then an equilibrium in the first tank is characterized by a value of S_1^* solution of the equation

$$\phi_{\rho,r}(S_1^*) = \frac{\mu(S_1^*)}{D} \quad (63)$$

where

$$\phi_{\rho,r}(s) = 1 + \frac{1-r}{r} \left(1 - \rho \frac{S_{in} - S_2^*(\rho)}{S_{in} - s} \right) \quad (64)$$

Notice that the graphs of the the family of functions $\phi_{\rho,r}$ are hyperbolas $H_{\rho,r}$ and thus S_1^* is the abscissa of the intersection of $H_{\rho,r}$ with the graph of the function μ/D on $(0, S_{in})$. Therefore we expect possibilities of have multiplicity of equilibriums, or only one intersection (cf Fig. 18). To help grasping the geometric condition (63), one can easily check that, once ρ is fixed, the family $H_{\rho,r}$ with $r \in (0, 1)$ has the following remarkable property

$$\phi_{\rho,r}(\underline{S}(\rho)) = 1, \quad \forall r \in (0, 1) .$$

where

$$\underline{S}(\rho) = \rho S_2^*(\rho) + (1 - \rho) S_{in} . \quad (65)$$

Notice also that the functions $s \mapsto \phi_{\rho,r}(s)$ are decreasing and that one has $\phi_{\rho,r}(\lambda^-(D)) > 1$ because $\rho < 1$ (cf condition 58) and $S_2^* = \lambda_-(\rho D) < \lambda^-(D)$. Therefore the number $\underline{S}(\rho)$ belongs to the interval $(\lambda_-(D), S_{in})$.

Let us explicit the condition (63) on the specific case of the Haldane function (54):

$$D(S_{in} - s - \rho(1-r)(S_{in} - S_2^*(\rho)))(K + s + s^2/K_I) = r\bar{\mu}s(S_{in} - s) . \quad (66)$$

S_1^* is then a root of a polynomial P of degree 3. So there exist at most three solutions of $\phi_{\rho,r}(s) = \mu(s)/D$. For small values of r , we remark that $\phi_{\rho,r}(0)$ is very large and $\phi_{\rho,r}$ has a high slope. On the contrary, for r near to 1, $\phi_{\rho,r}(0)$ is closed to 1 and $\phi_{\rho,r}$ has a light slope. Intuitively, we expect to have only one root for small values of r and three for large values of r . For \bar{r} such that there exists a solution S_1^* of $\phi_{\rho,\bar{r}}(s) = \mu(s)/D$ and $\phi'_{\rho,\bar{r}}(s) = \mu'(s)$, one has $P(S_1^*) = 0$ and $P'(S_1^*) = 0$, that is S_1^* is a double root of P (and there exists at most one such double root because P is of degree 3). At such S_1^* , the hyperbola $H_{\rho,\bar{r}}$ is tangent to the graph of $\mu(\cdot)$. Intuitively, this corresponds to the limiting case for the parameter r in between cases for which there is one or three roots (see Fig. 18 where tangent hyperbola are drawn in thick line).

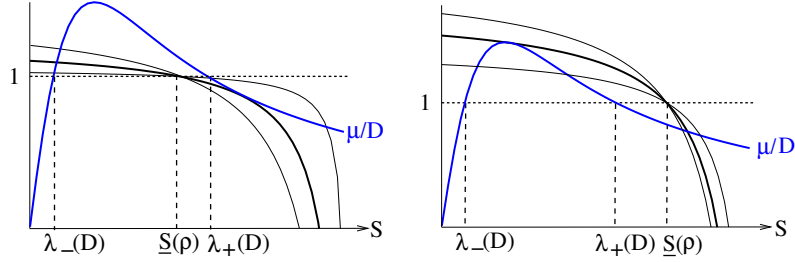

Figure 18: Examples of functions $\phi_{\rho,r}(\cdot)$ when $\underline{S}(\rho) < \lambda_+(D)$ (on the left) and $\underline{S}(\rho) > \lambda_+(D)$ (on the right), illustrated with an Haldane function (when $\lambda_+(D) < S_{in}$).

We formalize now this study in a more general setup.

3.3.2 Asymptotic behavior

Similarly to the single tank model where we have considered the set $\Lambda(D)$ given in (55), we define the set

$$\Gamma_{\rho,r}(D) = \{S \in (0, S_{in}) \mid \mu(S) > D\phi_{\rho,r}(S)\} . \quad (67)$$

and consider the subset of configurations for which system (56) admits a unique positive equilibrium, denoted by

$$\bar{R}_\rho(D) = \{r \in (0, 1) \mid \exists! s \in (0, S_{in}) \text{ s.t. } D\phi_{\rho,r}(s) = \mu(s)\} . \quad (68)$$

We assume that the second tank admits a positive equilibrium, which amounts to require the following hypothesis.

Hypothesis H4 D and ρ are positive numbers such that $\Lambda(\rho D) \neq \emptyset$ and $\lambda_-(\rho D) < S_{in}$.

Proposition 3.3.2. *Let Hypotheses H2c and H4 be fulfilled. The set $\Gamma_{\rho,r}(D)$ is non-empty, and for almost any $r \in (0, 1)$ one has the following properties, except from a subset of initial conditions of zero Lebesgue measure.*

- (i) *When the initial condition of the (S_2, X_2) sub-system belongs to the attraction basin of $(S_{in}, 0)$, the solution (S_1, X_1) of system (56) converges exponentially to the steady-state $(\lambda_-(D/r), S_{in} - \lambda_-(D/r))$ when $\lambda_-(D/r) < S_{in}$, or to the washout equilibrium when $\mu(S_{in}) < D/r$.*
- (ii) *When the initial condition of the (S_2, X_2) sub-system does not belong to the attraction basin of $(S_{in}, 0)$, the trajectory of the system (56) converges exponentially to a positive equilibrium*

$$E^* = (S_1^*, S_{in} - S_1^*, \lambda_-(\rho D), S_{in} - \lambda_-(\rho D))$$

where S_1^* is the left endpoint of a connected component of $\Gamma_{\rho,r}(D)$.

Moreover, the set $\overline{R}_\rho(D)$ is non-empty.

Proof. Let us consider the vector

$$Z = \begin{bmatrix} X_1 + S_1 - S_{in} \\ X_2 + S_2 - S_{in} \end{bmatrix}$$

whose dynamics is linear:

$$\dot{Z} = D \underbrace{\begin{pmatrix} -\frac{1}{r} & \frac{\rho(1-r)}{r} \\ 0 & -\rho \end{pmatrix}}_A Z .$$

The matrix A is clearly Hurwitz and consequently Z converges exponentially towards 0 in forward time. then, from equations (57), the dynamics of the variable S_1 can be written as a non-autonomous scalar equation:

$$\begin{aligned} \dot{S}_1 &= \left(-\mu(S_1) + D \frac{1-\rho(1-r)}{r} \right) (S_{in} - S_1) \\ &\quad + D \frac{\rho(1-r)}{r} (S_2(t) - S_1) - \mu(S_1) Z_1(t) \end{aligned} \quad (69)$$

When the initial condition of sub-system (S_2, X_2) belongs to the attraction basin of the washout, the dynamics (69) is asymptotically autonomous with the limiting equation

$$\dot{S}_1 = (-\mu(S_1) + D/r)(S_{in} - S_1) . \quad (70)$$

From Theorem A.2.1 (see Appendix A.2), we deduce that S_1 converges to S_1^* , one of the zeros of the function

$$f(s) = (-\mu(s) + D/r)(S_{in} - s)$$

on the interval $[0, S_{in}]$, that are S_{in} , $\lambda_-(D/r)$ (if $\lambda_-(D/r) < S_{in}$) and $\lambda_+(D/r)$ (if $\lambda_+(D/r) < S_{in}$). The Jacobian matrix of the whole dynamics (57) at steady state $(S_1^*, S_{in} - S_1^*, S_{in}, 0)$ in (Z, S_1, S_2) coordinates is

$$\left(\begin{array}{cc|cc} & & & \\ & \mathbf{A} & & \mathbf{0} \\ \hline & & & \\ -\mu(S_1^*) & 0 & f'(S_1^*) & D \frac{\rho(1-r)}{r} \\ 0 & -\mu(S_{in}) & 0 & \mu(S_{in}) - \rho D \end{array} \right) .$$

When the attraction basin of the washout of the (S_2, X_2) subsystem is not reduced to a singleton, one has necessarily $\mu(S_{in}) < \rho D$ (see Lemma A.6.1 in Appendix A.6). Furthermore, one has $f'(S_{in}) = \mu(S_{in}) - D/r$ and $f'(S_1^*) = -\mu'(S_1^*)(S_{in} - S_1^*)$ when $S_1^* < S_{in}$. So, apart two possible particular values of r that are such that $r = D/\mu(S_{in})$ or $\lambda_-(D/r) = \lambda_+(D/r) < S_{in}$, $f'(S_1^*)$ is non-zero and the equilibrium is thus hyperbolic. Finally, we conclude about the possible asymptotic behaviors of the whole dynamics as follows.

- The washout equilibrium is attracting when $\mu(S_{in}) < D/r$. When $\mu(S_{in}) > D/r$, this equilibrium is a saddle (with a stable manifold of dimension one). Accordingly to the Theorem of the Stable Manifold, the trajectory solution cannot converges to such an equilibrium, excepted from a measure-zero subset of initial conditions.
- When $\lambda_-(D/r) < S_{in}$, the equilibrium with $S_1^* = \lambda_-(D/r)$ is always attracting.

- When $\lambda_+(D/r) < S_{in}$, the equilibrium with $S_1^* = \lambda_+(D/r)$ is a saddle (with a stable manifold of dimension one). Accordingly to the Theorem of the Stable Manifold, the trajectory solution cannot converges to such an equilibrium, excepted from a measure-zero subset of initial conditions.

This finishes to prove the first point of the Proposition.

When the initial condition of sub-system (S_2, X_2) does not belong to the attraction basin of the washout, Proposition 3.3.1 ensures that $S_2(t)$ converges towards a positive S_2^* that is equal to $\lambda_-(\rho D)$ or $\lambda_+(\rho D)$. Then, equation (69) can be equivalently written as:

$$\dot{S}_1 = (D\phi_{\rho,r}(S_1) - \mu(S_1))(S_{in} - S_1) + D\frac{\rho(1-r)}{r}(S_2(t) - S_2^*) - \mu(S_1)Z_1(t). \quad (71)$$

So the dynamics (71) is asymptotically autonomous with the limiting equation

$$\dot{S}_1 = (D\phi_{\rho,r}(S_1) - \mu(S_1))(S_{in} - S_1). \quad (72)$$

From Theorem A.2.1 (see Appendix A.2), we conclude that forward trajectories of the (S_1, X_1) sub-system converge asymptotically either to a stationary point $(S_1^*, S_{in} - S_1^*)$ where S_1^* is a zero of the function

$$f_r(s) = D\phi_{\rho,r}(s) - \mu(s)$$

on the interval $(0, S_{in})$, either to the washout point $(S_{in}, 0)$. We show that this last case is not possible. From equations (57), one has

$$X_1 = 0 \implies \dot{X}_1 = D\frac{\rho(1-r)}{r}X_2$$

and as $X_2(t)$ converges to a positive value, we deduce that $X_1(t)$ cannot converges towards 0.

The functions f_r being analytic for any r , the roots S_1^* are isolated. Consider the function

$$\gamma(s) = \frac{\underline{S} - s}{\underline{S} - S_{in} + (S_{in} - s)\mu(s)/D}$$

that is analytic on its domain of definition and such that

$$f_r(s) = 0 \iff \gamma(s) = r.$$

This shows that, excepted for some isolated values of r in $(0, 1)$, the zero of f_r are such that $f'_r(S_1^*) \neq 0$.

Let us now write the Jacobian matrix J^* of dynamics (57) at steady state $E^* = (S_1^*, S_{in} - S_1^*, S_2^*, S_{in} - S_2^*)$ in (Z, S_1, S_2) coordinates:

$$J^* = \left(\begin{array}{cc|cc} \mathbf{A} & & & \mathbf{0} \\ \hline -\mu(S_1^*) & 0 & f'_r(S_1^*)(S_{in} - S_1^*) & D\frac{\rho(1-r)}{r} \\ 0 & -\mu(S_2^*) & 0 & -\mu'(S_2^*)(S_{in} - S_2^*) \end{array} \right).$$

Considering the following facts:

1. A is Hurwitz,
2. $\Lambda(\rho D) \neq \emptyset$ implies that S_2^* is not equal to \hat{S} . So one has $\mu'(S_2^*) \neq 0$ (cf Hypothesis H2c),
3. $f'_r(S_1^*) \neq 0$ for almost any r ,

we conclude that any equilibrium E^* is hyperbolic (for almost any r) and is

- a saddle point when $\mu'(S_2^*) > 0$ or $f_r'(S_1^*) > 0$,
- an exponentially stable critical point otherwise.

Furthermore, the left endpoints of the connected components of the set $\Gamma_{\rho,r}(D)$ are exactly the roots of f_r with $f_r(S_1^*) < 0$. Finally, from the Stable Manifold Theorem we conclude that, excepted from the stable manifolds of the saddle equilibriums, the trajectory converges to an equilibrium that is such that $S_2^* = \lambda_-(\rho D)$ and $f_r(S_1^*) < 0$. This ends the proof of the second point. \square

Remark 3.3.1. *The inequality $\underline{S}(\rho) > \lambda_-(D)$ implies $\phi_{\rho,r}(S) > \mu(S)/D$ for $S < \underline{S}(\rho)$. Therefore the value S_1^* (which is the output concentration at steady-state) is necessarily larger than $\lambda_-(D)$, which is the output concentration at steady-state for the single tank model at the positive equilibrium.*

3.3.3 Multiplicity of equilibriums

Under Hypothesis H2c, we consider the set of s at which the hyperbola $H_{\rho,r}$ is tangent to the graph of the function $\mu(\cdot)/D$ and is locally on one side (which amounts to have 0 as a local extremum of the function $\phi_{\rho,r}(\cdot) - \mu(\cdot)/D$ at s):

$$\mathcal{S}_{\rho,r}(D) = \{s \in (0, S_{in}) \text{ s.t. } n^*(s) \text{ is even and larger than } 1\} \quad (73)$$

where $n^*(\cdot)$ is defined as

$$n^*(s) = \min \left\{ n \in \mathbb{N} \text{ s.t. } D \frac{d^n \phi_{\rho,r}}{ds^n}(s) \neq \frac{d^n \mu}{ds^n}(s) \right\} .$$

We consider also the sets

$$R_\rho(D) = \{r \in (0, 1) \text{ s.t. } \mathcal{S}_{\rho,r}(D) \neq \emptyset\} . \quad (74)$$

The next proposition gives properties on these sets and the number of equilibriums.

Proposition 3.3.3. *Assume Hypothesis H2c is fulfilled and $D > 0$ is such that $\lambda_+(D) < S_{in}$. Take a positive number ρ such that Hypothesis H4 is satisfied. Let $S_2^*(\rho) \in (0, S_{in})$ be such that $\mu(S_2^*(\rho)) = \rho D$. Then, for any $r \in (0, 1)$ there exists an equilibrium $(S_1^*, S_{in} - S_1^*, S_2^*(\rho), S_{in} - S_2^*(\rho))$ of (57), with*

$$S_1^* \in \begin{cases} (\underline{S}(\rho), S_{in}) & \text{when } \Lambda(D) = \emptyset \text{ or } \underline{S}(\rho) \notin \Lambda(D) , \\ [\lambda_-(D), \underline{S}(\rho)] & \text{when } \underline{S}(\rho) \in \Lambda(D) . \end{cases} \quad (75)$$

Furthermore, the set $R_\rho(D)$ defined in (74) is not reduced to a singleton when it is non-empty. We consider a partition of the set $R_\rho(D)$ with

$$\begin{aligned} R_\rho^-(D) &= \{r \in (0, 1) \mid \exists s \in \mathcal{S}_{\rho,r}(D) \text{ s.t. } (s - \underline{S}(\rho))(\lambda_+(D) - \underline{S}(\rho)) < 0\} , \\ R_\rho^+(D) &= \{r \in (0, 1) \mid \exists s \in \mathcal{S}_{\rho,r}(D) \text{ s.t. } (s - \lambda_+(D))(\lambda_+(D) - \underline{S}(\rho)) \geq 0\} . \end{aligned}$$

Then, the set $R^+(\rho)$ is non-empty, and the set $R^-(\rho)$ is not reduced to a singleton when it is non-empty. One has

$$\bar{R}_\rho(D) = \begin{cases} (0, \min R^+(\rho)) , & \text{when } R^-(\rho) = \emptyset , \\ (0, \min R^+(\rho)) \cap (0, 1) \setminus [\min R^-(\rho), \max R^-(\rho)] , & \text{when } R^-(\rho) \neq \emptyset . \end{cases}$$

For any $r \in (\min R^+(\rho), 1)$, there exist at least two equilibriums such that $(\underline{S}(\rho) - S_1^*)(\lambda_+(D) - \underline{S}(\rho)) \geq 0$, and at least four for r in a subset of $(\min R^+(\rho), 1)$ when $R^+(\rho)$ is not reduced to a singleton.

When $R^-(\rho)$ is non-empty, for any $r \in (\min R^-(\rho), \max R^-(\rho))$, there exist at least three equilibriums such that $(\underline{S}(\rho) - S_1^*)(\lambda_+(D) - \underline{S}(\rho)) < 0$.

Remark 3.3.2. The tangency of the graphs of $\phi_{\rho,r}$ and μ occurs for a certain r with an abscissa that is located

- either at the right of λ_+ when $\underline{S}(\rho) < \lambda_+(D)$,
- either at the left of λ_+ when $\underline{S}(\rho) > \lambda_+(D)$.

These cases correspond to the subset $R_\rho^+(D)$ while the subset $R_\rho^-(D)$ corresponds to other tangencies that could occur (but that do not necessarily exist) on either side of $\underline{S}(\rho)$.

Proof of Proposition 3.3.3. For simplicity, we denote by S_2^* and \underline{S} the values of $S_2^*(\rho)$ and $\underline{S}(\rho)$, with S_2^* such that $\mu(S_2^*) = \rho D$. For each $r \in (0, 1)$, we define the function

$$f_r(s) = D\phi_{\rho,r}(s) - \mu(s) .$$

A non-negative equilibrium for the first tank has then to satisfy $f_r(S_1^*) = 0$.

One can easily check that $\phi_{\rho,r}(\underline{S}) = 1$ whatever the value of $r \in (0, 1)$. The function $\phi_{\rho,r}(\cdot)$ being decreasing, one has $\phi_{\rho,r}(s) > 1$ for $s < \underline{S}$ and $\phi_{\rho,r}(s) < 1$ for $s > \underline{S}$. For convenience, we shall also consider the function

$$\gamma(s) = \frac{\underline{S} - s}{\underline{S} - S_{in} + (S_{in} - s)\mu(s)/D} \quad (76)$$

that is defined on the set of $s \in (0, S_{in})$ such that $(S_{in} - s)\mu(s) \neq S_{in} - \underline{S}$. On this set, one can easily check that the following equivalence is fulfilled

$$f_r(s) = 0 \iff \gamma(s) = r .$$

From (76), one can also write

$$\gamma(s) = \frac{(\phi_{\rho,r}(s) - 1)\frac{r}{1-r}}{(\phi_{\rho,r}(s) - 1)\frac{r}{1-r} - 1 + \mu(s)/D}$$

and deduce the property

$$\gamma'(s) = 0 \iff \phi'_{\rho,r}(s)(\mu(s)/D - 1) = (\phi_{\rho,r}(s) - 1)\mu'(s)/D . \quad (77)$$

Recursively, one obtains for every integer n

$$\begin{aligned} & \left\{ \frac{d^p \gamma}{ds^p}(s) = 0, p = 1 \dots n \right\} \\ \iff & \left\{ D \frac{d^p \phi_{\rho,r}}{ds^p}(s)(\mu(s) - D) = (D\phi_{\rho,r}(s) - D) \frac{d^p \mu}{ds^p}(s), p = 1 \dots n \right\} . \end{aligned}$$

Consequently, the set $\mathcal{S}_{\rho,r}$ defined in (73) can be characterized as

$$\mathcal{S}_{\rho,r} = \left\{ s \in (\lambda_-, S_{in}) \text{ s.t. } \gamma(s) = r \text{ and } \min \left\{ n \in \mathbb{N}^* \mid \frac{d^n \gamma}{ds^n}(s) \neq 0 \right\} \text{ is even} \right\}$$

or equivalently

$$\mathcal{S}_{\rho,r} = \{ s \in (0, S_{in}) \text{ s.t. } \gamma(s) = r \text{ is a local extremum} \} . \quad (78)$$

In the following, we simply denote Λ , λ_\pm and R_ρ for $\Lambda(D)$, $\lambda_\pm(D)$ and $R_\rho(D)$ respectively, for simplicity.

We consider three sub-cases depending on the relative position of \underline{S} with respect to λ_+ .

Sub-case 1: $\underline{S} < \lambda_+$. As for Case I, we distinguish:

$\underline{S} \leq \lambda_-$: one has $f_r(\underline{S}) \geq 0$ and $f_r(S) < 0$ for any $S \in \Lambda$. $f_r(\cdot)$ being decreasing on $[0, \lambda_-]$, one deduces that there exists exactly one solution S_1^* of $f_r(S) = 0$ on the interval $[0, \lambda_+]$, whatever is r . Furthermore, this solution has to belong to $[\underline{S}, \lambda_-]$. The functions $\phi_r(\cdot)$ and $\mu(\cdot)$ being respectively decreasing and increasing on this interval, one has necessarily $\gamma'(S_1^*) \neq 0$ and then $R_\rho^- = \emptyset$.

$\underline{S} > \lambda_-$: one has $f_r(S) > 0$ for any $S \in [0, \lambda_-]$, and $f_r(S) < 0$ for any $S \in [\underline{S}, \lambda_+]$. On the interval $I = (\lambda_-, \underline{S})$, the function $\gamma(\cdot)$ is well defined and $\gamma(I) = (0, 1)$ with $\gamma(\lambda_-) = 1$ and $\gamma(\underline{S}) = 0$. If R_ρ^- is empty, then $\gamma(\cdot)$ is decreasing on I , and for any $r \in (0, 1)$ there exists a unique $S_1^* \in I$ such that $\gamma(S_1^*) = r$. If R_ρ^- is non-empty, property (78) implies that γ admits local extremums. Similarly to Case I, we obtain by the Mean Value Theorem that there exists exactly one solution S_1^* of $\gamma(s) = r$ on the interval $[0, \lambda_+]$ for any $r \notin [\min R_\rho^-, \min R_\rho^-]$, and there are at least three solutions for $r \in (\min R_\rho^-, \min R_\rho^-)$.

Notice that on interval $K = (\lambda_+, S_{in})$ the function $\gamma(\cdot)$ is well defined and positive with $\gamma(\lambda_+) = 1$ and $\lim_{s \rightarrow S_{in}} \gamma(s) = 1$. We define

$$r^+ = \min\{\gamma(s) \mid s \in K\}$$

that belongs to $(0, 1)$. Then r^+ belongs to R_ρ^+ , and for any $r < r^+$ there is no solution of $\gamma(s) = r$ on K . Thus r^+ is the minimal element of R_ρ^+ . By the Mean Value Theorem there are at least two solutions of $\gamma(s) = r$ on K when $r > r^+$. When R_ρ^+ is not reduced to a singleton, the function γ has at least on local maximum r_M and one local minimum r_m , in addition to r^+ . By the Mean Value Theorem, there are at least four solutions of $\gamma(s) = r$ on K for $r \in (r_m, r_M)$.

Finally, we have shown that the set R_ρ^+ is non-empty, and that the uniqueness of the solution of $\gamma(S_1^*) = r$ occurs exactly for values of r that do not belong to the set $[\min R_\rho^-, \max R_\rho^-] \cup [\min R_\rho^+, 1]$.

Sub-case 2: $\underline{S} = \lambda_+$. One has $f_r(\underline{S}) = 0$ for any r , so there exists a positive equilibrium with $S_1^* = \underline{S}$. $f_r(S) > 0$ for any $S \in [0, \lambda_-]$ and the function $\gamma(\cdot)$ is well defined on $I \cup J = (\lambda_-, \underline{S}) \cup (\underline{S}, S_{in})$ with $\gamma(I \cup J) = (0, 1)$, $\gamma(\lambda_-) = 1$ and $\lim_{s \rightarrow S_{in}} \gamma(s) = 1$. Using the L'Hôpital's rule, we show that the function $\gamma(\cdot)$ can be continuously extended at \underline{S} :

$$\lim_{s \rightarrow \underline{S}} \gamma(s) = \lim_{s \rightarrow \underline{S}} \frac{-1}{-\mu(s)/D + (S_{in} - s)\mu'(s)/D} = \frac{1}{1 - (S_{in} - \underline{S})\mu'(\underline{S})/D}.$$

Note that $\mu'(\underline{S}) < 0$ so that $\gamma(\underline{S})$ belongs to $(0, 1)$, and we pose

$$\bar{r} = \min\{\gamma(s) \mid s \in (\lambda_-, S_{in})\}.$$

Then, for $r < \bar{r}$, there is no solution of $\gamma(s) = r$ on (λ_-, S_{in}) , and \underline{S} is the only solution of $f_r(s) = 0$ on $(0, S_{in})$. On the contrary, for $r > \bar{r}$, there are at least two solutions of $\gamma(s) = r$ on (λ_-, S_{in}) and the dynamics has at least two positive equilibriums.

Similarly, the function $\gamma(\cdot)$ is C^1 on (λ_-, S_{in}) because it is differentiable at \underline{S} :

$$\gamma'(\underline{S}) = D \frac{(S_{in} - \underline{S})\mu''(\underline{S}) - 2\mu'(\underline{S})}{[D - (S_{in} - \underline{S})\mu'(\underline{S})]^2}$$

(and recursively as many time differentiable as the function $\mu(\cdot)$ is, minus one). Then \bar{r} is the minimal element of the set R_ρ^+ , and the set R_ρ^- is empty by definition. As previously, when R_ρ^+ is not reduced to a singleton, $\gamma(s) = r$ has at least four solutions for r in a subset of $(\min R_\rho^+, 1)$.

Sub-case 3: $\underline{S} > \lambda_+$. We proceed similarly as in sub-case 1. Note first that there is no solution of $f_r(s) = 0$ on the intervals $(0, \lambda_-)$ and $(\lambda_+, \underline{S})$ whatever is r .

On the set Λ , $\gamma(\cdot)$ is well defined with $\gamma(\Lambda) \subset (0, 1)$, $\gamma(\lambda_-) = 1$ and $\gamma(\lambda_+) = 1$ and we define

$$r^+ = \min\{\gamma(s) \mid s \in \Lambda\}$$

that belongs to $(0, 1)$. One has necessarily $r^+ = \min R_\rho^+$, and there is no solution of $\gamma(S_1^*) = r$ exactly when $r < r^+$. For $r > r^+$, there exist at least two solutions by the Mean Value Theorem, and four for a subset of $(r^+, 1)$ when R_ρ^+ is not reduced to a singleton.

On the interval $J = (\underline{S}, S_{in})$, the function $\gamma(\cdot)$ is well defined with $\gamma(J) = (0, 1)$, $\gamma(\underline{S}) = 0$ and $\gamma(S_{in}) = 1$. There exists at least one solution of $f_r(s) = 0$ on this interval. If $R_\rho^- = \emptyset$, $\gamma(\cdot)$ is increasing and there exists a unique solution of $\gamma(S_1^*) = r$ on J whatever is r . Otherwise, $\min R_\rho^-$ and $\max R_\rho^-$ are the smallest local minimum and largest local maximum of the function γ on the interval J , respectively. Then, uniqueness of S_1^* on J is achieved exactly for r that does not belong to $[\min R_\rho^-, \max R_\rho^-]$, and for $r \in (\min R_\rho^-, \max R_\rho^-)$, there are at least three solutions by the Mean Value Theorem. \square

Under the conditions of Proposition 3.3.2, consider the number

$$\bar{r}_D(\rho) = \sup \bar{R}_\rho(D) \quad (79)$$

that guarantees that for any (r, ρ) with $r < \bar{r}_D(\rho)$, the buffer configuration admits a unique (globally asymptotically stable) positive equilibrium. We study now the set of “stable” buffered configurations \mathcal{C}_D as the set of pairs (ρ, r) such that the chemostat model with buffer admits a unique positive equilibrium. The upper boundary of \mathcal{C}_D is thus given by the curve

$$\rho \in (0, \mu(S_{in})/D] \mapsto \bar{r}_D(\rho)$$

where $\bar{r}_D(\rho)$ is the single element of the set $R_\rho^+(D)$. Notice that the limiting case $\rho D = \mu(S_{in})$ can have also global stability (see Lemma A.6.1 in Appendix A.6).

Remark 3.3.3. *The map $(\rho, r) \mapsto S_1^*(\rho, r)$, where $S_1^*(\rho, r)$ is the unique solution of (63) on $(0, S_{in})$, is clearly continuous and one can then consider the limiting map:*

$$\bar{S}_1^*(\rho) = \lim_{r < \bar{r}_D(\rho), r \rightarrow \bar{r}_D(\rho)} S_1^*(\rho, r) .$$

When $\lambda_+(D) < S_{in}$, one has $\bar{S}_1^*(\rho) \leq \lambda_+(D)$ (resp. $\bar{S}_1^*(\rho) \geq \lambda_+(D)$) when $\underline{S}(\rho) < \lambda_+(D)$ (resp. $\underline{S}(\rho) > \lambda_+(D)$). Consider, if it exists, a value of ρ , denoted by $\underline{\rho}$, that is such that $\underline{S}(\underline{\rho}) = \lambda_+(D)$. Although one has $\phi_{\underline{\rho}, r}(\lambda_+(D)) = \mu(\lambda_+(D))/D$ for any r , there is no reason to have

$$\lim_{\rho < \underline{\rho}, \rho \rightarrow \underline{\rho}} \bar{S}_1^*(\rho) = \lambda_+(D) \quad \text{or} \quad \lim_{\rho > \underline{\rho}, \rho \rightarrow \underline{\rho}} \bar{S}_1^*(\rho) = \lambda_+(D) .$$

Consequently, the map $\rho \mapsto \bar{r}_D(\rho)$ might be discontinuous at such value $\underline{\rho}$.

The number $\bar{r}_D(\rho)$ can then be determined numerically as the unique minimizer of the function

$$F_\rho(r, s) = (\mu(s)/D - \phi_{\rho, r}(s))^2 + (\mu'(s)/D - \phi'_{\rho, r}(s))^2$$

on $(0, 1) \times \{s \in (\lambda^-(D), S_{in}) \text{ s.t. } (s - \lambda^+(D))(\lambda^+(D) - \underline{S}(\rho)) \geq 0\}$ that is, for the Haldane function:

$$F_\rho(r, s) = \left(\frac{(\bar{\mu}/D)s}{K+s+s^2/K_I} - \frac{1}{r} + \rho \frac{1-r}{r} \frac{S_{in} - \lambda_-(\rho D)}{S_{in} - s} \right)^2 + \left(\frac{\bar{\mu}/D(K-s^2/K_I)}{(K+s+s^2/K_I)^2} + \rho \frac{1-r}{r} \frac{S_{in} - \lambda_-(\rho D)}{(S_{in} - s)^2} \right)^2$$

where $\underline{S}(\rho)$ is defined in (65).

On Fig. 19, different domains $\mathcal{C}(D)$ are represented for the Haldane function, depending on the value of S_{in} (the values of the parameters are $\bar{\mu} = 12$, $D = 1$, $K = 1$, $K_I = 0.8$, which give $\lambda_-(D) \simeq 0.103$, $\lambda_+(D) \simeq 0.777$). One can see that the map $\rho \mapsto \bar{r}_D(\rho)$ is discontinuous at $\rho = \underline{\rho}$, where $\underline{\rho}$ is such that $\underline{S}(\underline{\rho}) = \lambda_+(D)$ (when it exists), as mentioned in Remark 3.3.3. On Fig. 20 one can see that the two limiting hyperbolas $H_{\rho, \bar{r}(\rho)}$ about $\underline{\rho}$ are different in a such a case.

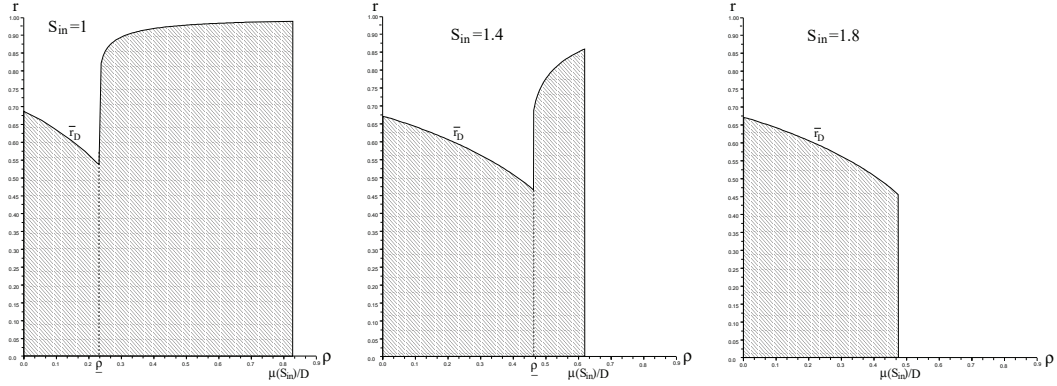

Figure 19: Domain \mathcal{C}_D of stable configurations for different values of S_{in} .

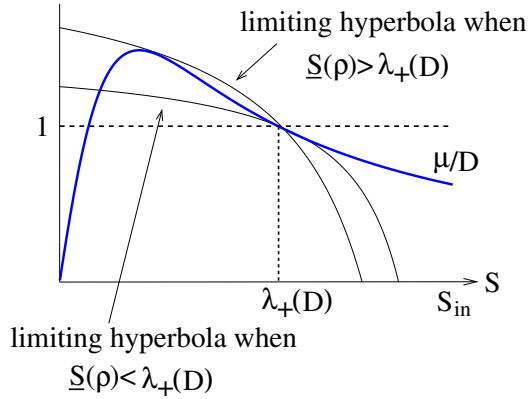

Figure 20: The limiting hyperbolas $H_{\rho, \bar{r}(\rho)}$ about $\rho = \underline{\rho}$ (for $S_{in} = 1.4$).

3.3.4 Discussion

From an ecological point of view. Proposition 3.3.2 shows that there exist buffered configurations (ρ, r) (with $S_{in} \in (\rho D)$ and $r \in \bar{R}_\rho(D)$) such that the overall dynamics has a unique globally stable positive equilibrium. Recall that we considered situations for which any invasive species cannot setup in a one tank or serial configuration. This property demonstrates that a simple (but particular) spatial structure such as the buffered one can explain the persistence of a species in an environment that is unfavorable if it was homogeneous. Furthermore, Proposition 3.3.2 shows that in absence of initial biomass in the main tank, a species seeded in the buffer can invade and persist in the main tank. We conclude that a buffer can play the role of a "refuge".

However, it can be shown (which as not been considered here, see [26]) that a buffer can create a multi-stability or even leads to a complete washout, while the dynamics has a positive globally asymptotically stable equilibrium in perfectly mixed conditions. So the buffered configuration can have positive or negative effects on the stability of an ecosystem, depending on the characteristics of the buffer (size and flow rate).

From a biotechnological point of view. A typical field of biotechnological applications is the waste-water treatment with micro-organisms. For such industries, a usual objective is to reduce the output concentration of substrate that is pumped out from the main tank. Typically, a species that is selected to be efficient for low nutrient concentrations could present a growth inhibition for large concentrations (its growth rate being thus non-monotonic). Usually, the input concentration S_{in} is imposed by the industrial discharge and cannot be changed, but the flow rate Q can be

manipulated. During the initial stage of continuous stirred bioreactors (that are supposed to be perfectly mixed), the biomass concentration is most often low (and the substrate concentration large). This means that there exists a risk that the initial state belongs to the attraction basin of the washout equilibrium if one immediately applies the nominal flow rate Q . Such situation could also occur during nominal functioning, under the temporary presence of a toxic material that could rapidly deplete part of the microbial population, and leave the substrate concentration higher than expected. Those situations are well known from the practitioners: the process needs to be monitored with the help of an automatic control that makes the flow rate Q decreasing in case of deviation toward the washout. But such a solution requires an upstream storage capacity when reducing the nominal flow rate, that could be costly. Keeping a constant input flow rate is thus preferable. An alternative is to oversize the volume of the tank so that there is no longer bi-stability and no need for a controller. Compared to these two solutions, a design with a main tank and a buffer (that guarantees a unique positive and globally asymptotically stable equilibrium) presents several advantages:

- It does not require to oversize the main tank,
- It does not require any upstream storage and the implementation of a controller,
- It allows to seed the initial biomass in the buffer tank only.

Notice that a by-pass of a single chemostat is also a way to reduce the effective flow rate and to avoid a washout. It happens to be a particular case of the buffered configuration with $V_1 = 0$.

Nevertheless, there is a price to pay to obtain the global stability over the single bi-stable tank configuration:

- If the buffered configuration has the same total volume than the single chemostat, then the output concentration at steady state S_1^* would be higher than $\lambda_-(D)$, meaning that the buffered configuration would be less efficient than the single chemostat at its (locally asymptotically) stable positive equilibrium.
- To obtain the same nominal output $\lambda_-(D)$ with a buffered configuration, one needs to have a larger total volume.

However, considering a single chemostat of volume V that presents a bi-stability (that is when $\Lambda(D) \neq \emptyset$ and $\lambda_+(D) < S_{in}$), one can compare the minimal volume increment required to obtain a single positive globally asymptotically stable equilibrium by one of the following scenarios:

- Scenario 1: enlarging the volume of the single chemostat by ΔV .
- Scenario 2: adding a buffer of volume V_2 .

For the first strategy, this amounts to have a new dilution rate equal to $D/(1 + \frac{\Delta V}{V})$. Then, the condition to be in Case 3 of Proposition 3.3.1 is to have

$$S_{in} \in \Lambda \left(\frac{D}{1 + \frac{\Delta V}{V}} \right),$$

or equivalently

$$\frac{\Delta V}{V} > \left(\frac{\Delta V}{V} \right)_m = \frac{D}{\mu(S_{in})} - 1. \quad (80)$$

For the second strategy, one has to choose first the dilution rate $D_2 = Q_2/V_2$ of the buffer (with $Q_2 < Q$). For any positive number $D_2 < \mu(S_{in})$, there exists a unique positive equilibrium $(S_2^*(D_2), S_{in} - S_2^*(D_2))$ in the buffer, where

$$S_2^*(D_2) = \lambda_-(D_2) < \bar{s} = \lambda_-(\mu(S_{in})).$$

Proposition 3.3.4. *Assume that the hypothesis H2c is fulfilled with $\Lambda(D) \neq \emptyset$ and $\lambda_+(D) < S_{in}$. There exist buffered configurations with an additional tank of volume V_2 that possesses a unique globally exponentially stable positive equilibrium from any initial condition with $S_2(0) > 0$, exactly when V_2 fulfills the condition*

$$\frac{V_2}{V} > \left(\frac{V_2}{V}\right)_m = \frac{\max_{s \in (\lambda_+(D), S_{in})} \varphi(s)}{\max_{s \in [0, \bar{s}]} \psi(s)}, \quad (81)$$

where the functions $\varphi(\cdot)$ and $\psi(\cdot)$ are defined as follows:

$$\varphi(s) = (S_{in} - s)(D - \mu(s)), \quad \psi(s) = \mu(s)(S_{in} - s), \quad (82)$$

and \bar{s} is the number

$$\bar{s} = \lim_{\rho \rightarrow \mu(S_{in})} S_2^*(\rho). \quad (83)$$

The dilution rate $D_2 \in (0, \mu(S_{in}))$ has then to satisfy the condition

$$\max_{s \in (\lambda_+(D), S_{in})} \varphi(s) < D_2 \frac{V_2}{V} (S_{in} - S_2^*(D_2)) < S_{in}.$$

Furthermore, one has

$$\left(\frac{V_2}{V}\right)_m < \left(\frac{\Delta V}{V}\right)_m. \quad (84)$$

Proof. One can straightforwardly check on equations (56) that a positive equilibrium in the first tank has to fulfill

$$\varphi(S_1^*) = D_2 \frac{V_2}{V} (S_{in} - S_2^*(D_2)). \quad (85)$$

Let us examine some properties of the function φ on the interval $(0, S_{in})$:

1. φ is negative exactly on the interval $\Lambda(D)$,
2. φ' is negative on $(0, \lambda_-(D))$ with $\varphi(0) = S_{in}$ and $\varphi(\lambda_-(D)) = 0$,
3. $\varphi(\lambda_+(D)) = \varphi(S_{in}) = 0$ and φ reaches its maximum m^+ on the sub-interval $(\lambda_+(D), S_{in})$, that is strictly less than $S_{in} = \varphi(0)$,

from which we deduce that there exists a unique solution of $\varphi(s) = c$ on the whole interval $(0, S_{in})$ exactly when $c \in (m^+, S_{in})$ (see Fig. 21 as an illustration). The configurations for which there

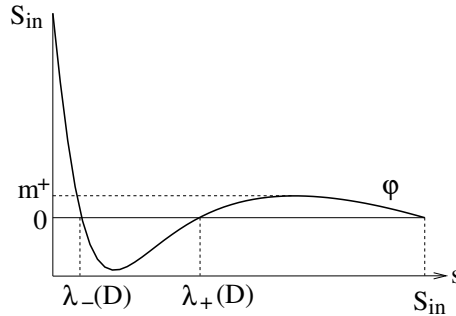

Figure 21: Illustration of the graph of the function φ .

exists a unique $S_1^* \in (0, S_{in})$ solution of the equation (85) are exactly those that fulfill the condition $D_2 \frac{V_2}{V} (S_{in} - S_2^*(D_2)) \in (m^+, S_{in})$, or equivalently

$$\frac{m^+}{D_2(S_{in} - S_2^*(D_2))} < \frac{V_2}{V} < \frac{S_{in}}{D_2(S_{in} - S_2^*(D_2))}$$

with $D_2 \in (0, \mu(S_{in}))$. Then, Proposition 3.3.2 with $\rho = D_2/D$ and $r = 1/(1 + \frac{V_2}{V})$ guarantees that the unique positive equilibrium $(S_1^*, S_{in} - S_1^*, S_2^*(D), S_{in} - S_2^*(D))$ is globally exponentially stable on the domain $\mathbb{R}_+^2 \times \mathbb{R}_+^*$.

Among all such configurations, the infimum of V_2/V can be approached arbitrarily close when D_2 is maximizing the function

$$D_2 \mapsto \rho(S_{in} - S_2^*(D_2))$$

on $[0, \mu(S_{in})]$, that exactly amounts to maximize the function $\psi(\cdot)$ on the interval $[0, \bar{s}]$.

Finally, let s^* be a minimizer of φ on $(\lambda_+(D), S_{in})$. One has $\mu(s^*) > \mu(S_{in}) = \mu(\bar{s})$ and can write

$$\left(\frac{V_2}{V}\right)_m \leq \frac{\varphi(s^*)}{\psi(\bar{s})} < \frac{(S_{in} - s^*)(D - \mu(S_{in}))}{\mu(S_{in})(S_{in} - \bar{s})} = \frac{S_{in} - s^*}{S_{in} - \bar{s}} \left(\frac{\Delta V}{V}\right)_m$$

which leads to the inequality (84). \square

This result provides an explicit lower bound on the volume V_2 to ensure a unique globally exponentially stable positive equilibrium from any initial condition with $S_2(0) > 0$. Furthermore, this bound is necessarily such that

$$\left(\frac{V_2}{V}\right)_m < \left(\frac{\Delta V}{V}\right)_m.$$

The benefit of Scenario 2 over Scenario 1 in terms of volume increment is numerically demonstrated on Fig. 22 (for the same values of the parameters that have been considered previously).

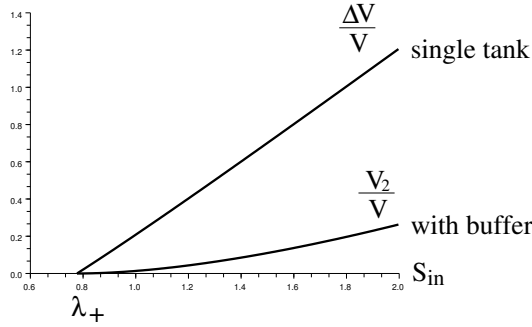

Figure 22: Comparison of the minimal increase of volume required to obtain the global stability.

A Appendices

A.1 Compartmental and M-matrices

A square matrix A is said to be *compartmental* if it fulfills the following properties

- i. $A_{ii} \leq 0$ for any indice i ,
- ii. $A_{ij} \geq 0$ for any indices $i \neq j$,
- iii. for any indice i , one has $\sum_j A_{ij} \leq 0$

A matrix A is *diagonal dominant* when there exists positive numbers $d_1 \cdots d_n$ such that

$$d_i |A_{ii}| > \sum_{j \neq i} d_j |A_{ji}|, \quad \forall i = 1 \cdots n \quad (86)$$

and matrices A such that $-A$ is compartmental and diagonal dominant are called *M-matrices*.

A matrix is *irreducible* if it is not similar via a permutation to a block upper triangular matrix (that has more than one block of positive size). Replacing non-zero entries in the matrix by one, and viewing the matrix as the adjacency matrix of a directed graph, the matrix is irreducible if and only if such directed graph is strongly connected.

A compartmental matrix is said to be *outflow connected* if its adjacency graph as the property that there exists a node j such that from any node $i \neq j$ there exists a path from i to j .

One has the following properties for the compartmental (see [5, 14]) and M-matrices (see [2]).

Theorem A.1.1. *An compartmental matrix that is outflow-connected is Hurwitz (i.e. all the real parts of its eigenvalues are negative).*

Theorem A.1.2. *A M-matrix is non-singular and its inverse is non-negative (i.e. all its elements are non-negative).*

A.2 Semi-flows and asymptotically autonomous dynamics

Consider a non-autonomous dynamics in \mathbb{R}^n :

$$\dot{x} = f(t, x) \quad (87)$$

We say that the dynamics is *asymptotically autonomous* with limiting dynamics

$$\dot{y} = g(y) \quad (88)$$

if $f(t, x) \rightarrow g(x)$ when $t \rightarrow +\infty$, uniformly on each compact of \mathbb{R}^n . Under the assumption that f and g are continuous and the initial value problem for each dynamics has unique solution defined for any future times, we consider the (non-autonomous) semi-flow associated to the dynamics f as the mapping

$$\Phi : \{(t, s) : \infty < s \leq t < \infty\} \times \mathbb{R}^n \rightarrow \mathbb{R}^n$$

where $\Phi(t, s, x_0)$ is the solution $x(\cdot)$ of (87) with $x(s) = x_0$. Similarly, we associate to the dynamics g the autonomous semi-flow

$$\Theta : \mathbb{R}_+ \times \mathbb{R}^n \rightarrow \mathbb{R}^n$$

where $\Theta(t, x_0)$ is the solution $y(\cdot)$ of (88) with $y(0) = x_0$.

The ω -limit set of a bounded solution $x(\cdot)$ of (87) on $t \geq t_0$ with $x(t_0) = x_0$ is defined as

$$\omega(t_0, x_0) := \left\{ y : y = \lim_{n \rightarrow \infty} x(t_n) \text{ for some sequence } t_n \rightarrow +\infty \right\}$$

Let Θ be an autonomous semi-flow. A non-empty positively invariant subset S of \mathbb{R}^n is said to be *chain recurrent* if any point in S is chain recurrent in S . A point x in S is chain recurrent in S if for any $\epsilon > 0$ and $t > 0$ there exists an (ϵ, t) chain from x to x in S . An (ϵ, t) chain from x to y in S is a sequence $\{x_1 = x, \dots, x_n = y; t_1, \dots, t_{n-1}\}$ with x_i in S and $t_i > t$ such that $d(\Theta(t_i, x_i), x_{i+1}) < \epsilon$ for any $i = 1, \dots, n-1$.

We recall a result from [21, Theorem 1.8].

Theorem A.2.1. *Let Φ be an asymptotically autonomous semi-flow with limit semi-flow Θ , and let the orbit $\mathcal{O}_\Phi(\tau, \xi)$ have compact closure. Then the ω -limit set $\omega_\Phi(\tau, \xi)$ is non-empty, compact, connected, invariant and chain-recurrent by the semi-flow Θ and attracts $\Phi(t, \tau, \xi)$ when $t \rightarrow \infty$.*

A.3 Partial orders and monotone dynamical systems

Given a cone K of \mathbb{R}^n , the partial order \leq_K on \mathbb{R}^n is defined by $x \leq_K y$ if $y - x \in K$. The partial order $<_K$ on \mathbb{R}^n is defined by $x <_K y$ if $x \leq_K y$ and $x_i \neq y_i$ for any $i = 1, \dots, n$. When $K = \mathbb{R}_+^n$, we simply write $x \leq y$ and $x < y$.

Consider a non-autonomous dynamics

$$\dot{x} = f(t, x) \tag{89}$$

defined on $\mathcal{D} = \mathbb{R}^n$ (or a positively invariant convex subset of \mathbb{R}^n) for $t \geq 0$, where f is C^1 with respect to x , and π its semi-flow (whose definition is recalled in section A.2). The dynamics (89) is said to be *monotone* with respect to \leq_K on \mathcal{D} if the property

$$x \leq_K y \Rightarrow \pi(t, x) \leq_K \pi(t, y) \text{ for any } t > 0$$

holds for any x, y in \mathcal{D} . The dynamics is said to be *strongly monotone* with respect to \leq_K if the property

$$x \leq_K y \Rightarrow \pi(t, x) >_K \pi(t, y) \text{ for any } t > 0$$

is verified for any x, y in \mathcal{D} . The dynamics (89) is said to be *cooperative* on \mathcal{D} if the property

$$[\text{Jac } f(t, x)]_{ij} = \frac{\partial_i f}{\partial x_j}(t, x) \geq 0,$$

is fulfilled for any $t \geq 0$ and x in \mathcal{D} . Then, one has the following property (see for instance [32, Theorem C.1])

Theorem A.3.1. *If (89) is cooperative on \mathcal{D} then (89) is monotone with respect to \leq on \mathcal{D} . If furthermore the Jacobian matrix of f is irreducible at any $(t, x) \in \mathbb{R}_+ \times \mathcal{D}$, then (89) is strongly monotone with respect to \leq on \mathcal{D} .*

Consider now autonomous dynamics

$$\dot{x} = f(x) \tag{90}$$

on \mathcal{D} . Denote by $\gamma^+(x_0)$ the forward orbit of $x_0 \in \mathcal{D}$:

$$\gamma^+(x_0) := \{\pi(t, x_0), t \geq 0\}.$$

and by E be the set of equilibria of (90) in \mathcal{D} . One has then the following result (see for instance [32, Theorem C.8]).

Theorem A.3.2. *Assume that (90) is strongly monotone on \mathcal{D} and E has no accumulation point in \mathcal{D} . If $\gamma^+(x)$ has a compact closure for any x in \mathcal{D} , then the set of points $x_0 \in \mathcal{D}$ for which $\pi(t, x_0)$ does not converge to an equilibrium has null Lebesgue measure.*

See [31] for a recent review of results about monotone dynamical systems.

A.4 Stability result for the model with lateral diffusive compartment

Proposition A.4.1. *When the washout equilibrium E^0 is the unique steady state, it is globally asymptotically stable on \mathbb{R}_+^4 . When the positive steady state E^* exists, for any initial condition except on a set of null measure, the solution of (22) converges asymptotically to E^* , which is moreover locally exponentially stable.*

Proof. Consider the variables $z_i = s_{\text{in}} - s_i - x_i$ for each tank $i = 1, 2$ and the dynamics (22) in (z, s) coordinates:

$$\begin{cases} \dot{z}_1 &= -\frac{Q}{V_1}z_1 - \frac{d}{V_1}(z_1 - z_2), \\ \dot{s}_1 &= -\mu(s_1)(s_{\text{in}} - s_1 - z_1) + \frac{Q}{V_1}(s_{\text{in}} - s_1) + \frac{d}{V_1}(s_2 - s_1), \\ \dot{z}_2 &= -\frac{Q}{V_2}(z_2 - z_1), \\ \dot{s}_2 &= -\mu(s_2)(s_{\text{in}} - s_2 - z_2) + \frac{d}{V_2}(s_1 - s_2). \end{cases} \quad (91)$$

This system has a cascade structure with a first independent sub-system linear in z

$$\dot{z} = \underbrace{\begin{bmatrix} -\frac{Q+d}{V_1} & \frac{d}{V_1} \\ \frac{d}{V_2} & -\frac{d}{V_2} \end{bmatrix}}_A z, \quad (92)$$

where one has

$$\text{tr}(A) = -\frac{Q+d}{V_1} - \frac{d}{V_2} < 0 \quad \text{and} \quad \det(A) = \frac{Qd}{V_1V_2} > 0.$$

Therefore the matrix A is Hurwitz and any solution z of (92) converges exponentially to 0.

The Jacobian matrix in the (z, s) coordinates depends only on s and is equal to

$$J(s) = \begin{bmatrix} A & 0 \\ B(s) & J_a(s) \end{bmatrix} \quad \text{with} \quad J_a(s) = \begin{bmatrix} -\frac{d}{V_1}\phi_1'(s_1) & \frac{d}{V_1} \\ \frac{d}{V_2} & -\frac{d}{V_2}\phi_2'(s_2) \end{bmatrix}, \quad B(s) = \begin{bmatrix} \mu(s_1) & 0 \\ 0 & \mu(s_2) \end{bmatrix}$$

Accordingly to Proposition 3.1.1, the equilibrium $E^* \neq E^0$ exists when $P(\mu(s_{\text{in}})) > 0$ or $\mu(s_{\text{in}}) > Q/V_1$.

- When $P(\mu(s_{\text{in}})) > 0$, one has $\phi_1'(s_{\text{in}})\phi_2'(s_{\text{in}}) < 1$ or equivalently $\det(JF_a(s^0)) < 0$. Then E^0 is a saddle point (with a stable manifold of dimension one).
- When $\mu(s_{\text{in}}) > Q/V_1$, notice that the equilibrium E^0 is not necessarily hyperbolic (as one can have $P(\mu(s_{\text{in}})) = 0$ which implies then $\det(JF_a(s^0)) = 0$) and we cannot conclude its stability properties directly.

The solution s can be written as the solution of the non autonomous dynamics

$$\dot{s} = F(t, s) = \begin{bmatrix} \left(\frac{Q}{V_1} - \mu(s_1)\right)(s_{\text{in}} - s_1) + \frac{d}{V_1}(s_2 - s_1) + \mu(s_1)z_1(t) \\ -\mu(s_2)(s_{\text{in}} - s_2) + \frac{d}{V_2}(s_1 - s_2) + \mu(s_2)z_2(t) \end{bmatrix}. \quad (93)$$

Notice that, for any (t, s) , one has

$$\frac{\partial F_1(t, s)}{\partial s_2} = \frac{d}{V_1} > 0 \quad \text{and} \quad \frac{\partial F_2(t, s)}{\partial s_1} = \frac{d}{V_2} > 0,$$

and so the dynamics (93) is cooperative (the definition is recalled in Section A.3). Moreover it is irreducible when $\mu(s_1)$ or $\mu(s_2)$ is non null. Then, the dynamics is strongly monotone on the invariant domain $\mathcal{D} := \mathbb{R}^2 \times (\mathbb{R}_+ \setminus \{0\})^2$ (cf Theorem A.3.1). As any forward orbit of (91) in \mathcal{D} is bounded (see Proposition 2.1), we can use Theorem A.3.2 to conclude that for any initial condition of (22) in \mathbb{R}_+^4 , except on a set of null measure, the trajectory solution converges asymptotically to an equilibrium. Finally, when the equilibrium E^* exists, one can see from the proof of Proposition 3.1.1 that one has necessarily $\gamma'(s_2^*) > 0$ (because $\gamma(0) < 0$, $\gamma(\lambda_1(s_{in})) \geq 0$ and γ is strictly concave). This implies $\phi_1'(s_1^*)\phi_2'(s_2^*) > 1$ and so $\phi_2'(s_2^*) > 0$. Then, one has $\text{tr}(J_a(s^*)) < 0$ and $\det(J_a(s^*)) > 0$ i.e. $J(s^*)$ is Hurwitz, which proves that the attractive equilibrium E^* is also locally exponentially stable. \square

A.5 Stability result for the model with two vessels in parallel

Proposition A.5.1. *When $s_{in} > 1$ and $d > 0$, any trajectory of (48) with initial condition in \mathbb{R}_+^4 such that $x_1(0) > 0$ and $x_2(0) > 0$ converges exponentially to the unique non-trivial steady-state $(s_1^*, x_1^*, s_2^*, x_2^*)$ given by Proposition 3.2.2.*

Proof. We consider the 2-dimensional vector z of variables $z_i = s_{in} - x_i - s_i$ ($i = 1, 2$) whose dynamics is

$$\dot{z} = A_p z = \begin{bmatrix} -\alpha_1 - \frac{d}{r} & \frac{d}{r} \\ \frac{d}{1-r} & -\alpha_2 - \frac{d}{1-r} \end{bmatrix} z$$

where A_p is Hurwitz :

$$\text{tr}(A_p) = -\alpha_1 - \alpha_2 - \frac{d}{r} - \frac{d}{1-r} < 0, \quad \det(A_p) = \alpha_1 \alpha_2 + \frac{d}{r(1-r)} > 0$$

So z converges exponentially toward 0, which implies that dynamics (48) is dissipative, in the sense that any solution of (48) in \mathbb{R}_+^4 converge exponentially to the compact set $K = \{(s_1, x_1, s_2, x_2) \in \mathbb{R}_+^4 \text{ s.t. } x_1 + s_1 = s_{in} \text{ and } x_2 + s_2 = s_{in}\}$.

Considering the time vector $z(\cdot)$, the (s_1, s_2) sub-system of dynamics (48) can be written as solution of a non-autonomous planar dynamics

$$\begin{cases} \dot{s}_1 &= s_1(z_1(t) + s_1 - s_{in}) + \alpha_1(s_{in} - s_1) + \frac{d}{r}(s_2 - s_1) \\ \dot{s}_2 &= s_2(z_2(t) + s_2 - s_{in}) + \alpha_2(s_{in} - s_2) + \frac{d}{1-r}(s_1 - s_2) \end{cases} \quad (94)$$

We know that z converges to 0 and consequently the vector S of variables s_1, s_2 converges to the set $\mathcal{S} = [0, s_{in}] \times [0, s_{in}]$. We study now the limiting autonomous dynamics

$$\begin{cases} \dot{s}_1 &= (s_{in} - s_1)(\alpha_1 - s_1) + \frac{d}{r}(s_2 - s_1) \\ \dot{s}_2 &= (s_{in} - s_2)(\alpha_2 - s_2) + \frac{d}{1-r}(s_1 - s_2) \end{cases} \quad (95)$$

on the domain \mathcal{S} . Let \mathcal{B} be the boundary $\{s_1 = s_{in}\} \cup \{s_2 = s_{in}\}$. On the domain $\mathcal{S} \setminus \mathcal{B}$, we consider the vector σ of variables $\sigma_i = \log(s_{in} - s_i)$, whose dynamics can be written as follows

$$\dot{\sigma} = F(\sigma) = \begin{bmatrix} -\alpha_1 + s_{in} - e^{\sigma_1} - \frac{d}{r}(1 - e^{\sigma_2 - \sigma_1}) \\ -\alpha_2 + s_{in} - e^{\sigma_2} - \frac{d}{1-r}(1 - e^{\sigma_1 - \sigma_2}) \end{bmatrix} \quad (96)$$

One can easily compute

$$\text{div}(F) = -e^{\sigma_1} - e^{\sigma_2} - \frac{d}{r}e^{\sigma_2 - \sigma_1} - \frac{d}{1-r}e^{\sigma_1 - \sigma_2} < 0$$

From Poincaré-Bendixon theorem and Dulac criterion, we conclude that bounded trajectories of (96) cannot have limit cycle or closed path and necessarily converge to an equilibrium point.

Consequently, any trajectory of (95) in \mathcal{S} either converges to the rest point $S^* = (s_1^*, s_2^*)$ or approaches the boundary \mathcal{B} . Notice that one has

$$s_i = s_{in}, s_j < s_{in} \Rightarrow \dot{s}_i < 0 \quad (i \neq j)$$

So the only possibility for approaching \mathcal{B} is to converge to the other rest point $S^0 = (s_{in}, s_{in})$. This shows that the only non-empty, closed, connected, invariant and chain recurrent subsets of \mathcal{S} are the singletons $\{S^*\}$ and $\{S^0\}$.

Applying Theorem A.2.1 we conclude that any trajectory of (94), issued from initial condition of dynamics (48) in \mathbb{R}_+^4 , converges asymptotically to S^* or S^0 . Consider now any initial condition with $x_1(0) > 0$ and $x_2(0) > 0$. We show that the solution $(s_1(\cdot), s_2(\cdot))$ of (48) cannot converge to S^0 . If it is the case, there exists $T < +\infty$ such that one has

$$s_1(t) > \alpha_1 \quad \text{and} \quad r s_1(t) + (1-r)s_2(t) > 1 \quad \text{for any } t \geq T$$

under the assumption $s_{in} > 1$. Let us consider the function

$$V(x_1, x_2) = \min(rx_1 + (1-r)x_2, x_1)$$

(see Figure 23) and $v(t) = V(x_1(t), x_2(t))$ that is positive and tends to 0 when t tends to $+\infty$

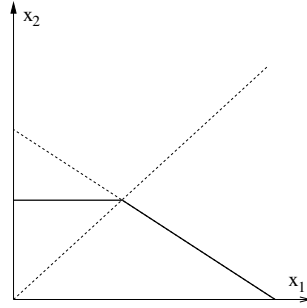

Figure 23: Iso-value of the function V .

If $x_1(t) < x_2(t)$, one has $v(t) = x_1(t)$ and

$$\dot{v} = \dot{x}_1 > (s_1(t) - \alpha_1)x_1 > 0 \quad \text{for } t \geq T$$

If $x_1(t) > x_2(t)$, one has $v(t) = rx_1(t) + (1-r)x_2(t)$ and

$$\begin{aligned} \dot{v} &= r\dot{x}_1 + (1-r)\dot{x}_2 = r(s_1 - \alpha_1)x_1 + (1-r)(s_2 - \alpha_2)x_2 \\ &> (rs_1 + (1-r)s_2 - 1)x_2 > 0 \quad \text{for } t \geq T \end{aligned}$$

We conclude that the function $t \mapsto v(t)$ is non-decreasing for $t \geq T$ and consequently cannot converge to zero, thus a contradiction.

The Jacobian matrix of dynamics (48) at the non-trivial equilibrium $(s_1^*, x_1^*, s_2^*, x_2^*)$ is of the following form in (z_1, z_2, s_1, s_2) coordinates

$$\begin{bmatrix} A_p & 0 \\ \star & J^* \end{bmatrix} \quad \text{with} \quad J^* = \begin{bmatrix} -\frac{d}{r}\phi_2'(s_1^*) & \frac{d}{r} \\ \frac{d}{1-r} & -\frac{d}{1-r}\phi_1'(s_2^*) \end{bmatrix}$$

Recall that A_p is Hurwitz. One has

$$\det(J^*) = \frac{d^2}{r(1-r)}(\phi_1'(s_2^*)\phi_2'(s_1^*) - 1) \quad \text{and} \quad \text{tr}(J^*) = -\frac{d}{r}\phi_2'(s_1^*) - \frac{d}{1-r}\phi_1'(s_2^*) .$$

The function $\phi_1(\cdot)$ being concave, one has $\phi_1(s_{in}) \leq \phi_1(s_2^*) + \phi_1'(s_2^*)(s_{in} - s_2^*)$. Along with the inequalities $s_{in} > s_2^*$ and $\phi_1(s_{in}) = s_{in} > s_1^* = \phi_1(s_2^*)$, one deduces $\phi_1'(s_2^*) > 0$. Recall from Corollary 3.2.1 that one has $g'(s_1^*) = \phi_1'(s_2^*)\phi_2'(s_1^*) - 1 > 0$. Then the inequality $\phi_2'(s_1^*) > 0$ is necessarily satisfied. Finally, we have shown $\det(J^*) > 0$ and $\text{tr}(J^*) < 0$, that guarantee the exponential stability of the non-trivial equilibrium $(s_1^*, x_1^*, s_2^*, x_2^*)$. \square

Remark A.5.1. *The wash-out equilibrium $(s_{in}, 0, s_{in}, 0)$ is not necessarily hyperbolic. This explains why we cannot use the Convergence Theorem for asymptotically autonomous dynamics given in Appendix F of [32].*

A.6 The buffer tank with non-hyperbolic equilibrium

The following lemma allows to deal with the limiting case $\mu(S_{in}) = \rho D$ for the buffer tank with $\mu(\cdot)$ non-monotonic (this is a non generic case that is usually not considered in the classical literature, and that cannot be treated with the usual arguments because the wash-out equilibrium is not hyperbolic in this particular situation).

Lemma A.6.1. *For any $\rho > 0$ such that $\rho D \leq \mu(S_{in})$ and non-negative initial condition with $X_2(0) > 0$, the solution of (57) satisfies*

$$\lim_{t \rightarrow +\infty} (S_2(t), X_2(t)) = (\lambda_-(\rho D), S_{in} - \lambda_-(\rho D)) .$$

Proof. Considering the variable $Z_2 = S_2 + X_2 - S_{in}$, one obtains from equations (57) the dynamics $\dot{Z}_2 = -\rho D Z_2$. We deduce that $S_2(t)$ and $X_2(t)$ satisfy

$$\lim_{t \rightarrow +\infty} S_2(t) + X_2(t) = S_{in} .$$

The dynamics of the variable S_2 can thus be written with an non autonomous scalar equation:

$$\dot{S}_2 = (\rho D - \mu(S_2))(S_{in} - S_2) - \mu(S_2)Z_2(t)$$

that is asymptotically autonomous. The study of this asymptotic dynamics is straightforward: any trajectory that converges forwardly to the domain $[0, S_{in}]$ has to converge to S_{in} or to a zero S_2^* of $S_2 \mapsto \rho D - \mu(S_2)$ on the interval $(0, S_{in})$. Then, the application of Theorem A.2.1 allows to conclude that forward trajectories of the (S_2, X_2) sub-system converge asymptotically either to the positive steady state $(S_2^*, S_{in} - S_2^*)$ or to the “washout” equilibrium $(S_{in}, 0)$.

For ρ such that $\rho D < \mu(S_{in})$, there is only one such zero, that is equal to $\lambda_-(\rho D)$ (and necessarily lower than S_{in}). We are in conditions of Case 3 of Proposition 3.3.1: $S_{in} \in \Lambda(\rho D)$, and the convergence to the positive equilibrium is proved.

For the limiting case $\rho D = \mu(S_{in})$, either $\lambda_-(\rho D) = S_{in}$ when $\mu(\cdot)$ is monotonic on the interval $[0, S_{in}]$ (then the washout is the only equilibrium), or $\lambda_-(\rho D) < S_{in}$ when $\mu(\cdot)$ is non-monotonic. In this last situation, none of the cases of Proposition 3.3.1 are fulfilled. We show that for any initial condition such that $X_2(0) > 0$, the forward trajectory cannot converge to the washout equilibrium. From equations (57) one can write

$$X_2(t) = X_2(0) e^{\int_0^t (\mu(S_2(\tau)) - \rho D) d\tau} .$$

If $X_2(\cdot)$ tends to 0, then one should have

$$\int_T^{+\infty} (\mu(S_2(\tau)) - \rho D) d\tau = -\infty \tag{97}$$

for any finite positive T . Using Taylor-Lagrange Theorem, there exists a continuous function $\theta(\cdot)$ in $(0, 1)$ such that

$$\mu(S_2(\tau)) = \mu(S_{in}) + \mu'(\tilde{S}_2(\tau))(S_2(\tau) - S_{in})$$

with

$$\tilde{S}_2(\tau) = S_{in} + \theta(\tau)(S_{in} - S_2(\tau)) .$$

One can then write

$$\begin{aligned} \int_T^{+\infty} (\mu(S_2(\tau)) - \rho D) d\tau &= \int_T^{+\infty} (\mu(S_{in}) - \rho D) d\tau - \int_T^{+\infty} \mu'(\tilde{S}_2(\tau)) X_2(\tau) d\tau \\ &\quad + \int_T^{+\infty} \mu'(\tilde{S}_2(\tau)) Z_2(\tau) d\tau \\ &= - \int_T^{+\infty} \mu'(\tilde{S}_2(\tau)) X_2(\tau) d\tau - \frac{1}{\rho D} \int_T^{+\infty} \mu'(\tilde{S}_2(\tau)) \dot{Z}_2(\tau) d\tau \end{aligned}$$

Note that $S_2(\cdot)$ tends to S_{in} when $X_2(\cdot)$ tends to 0. So there exists $T > 0$ such that $\tilde{S}_2(\tau) > \hat{S}$ for any $\tau > T$, and accordingly to Hypothesis H2c, there exist positive numbers a, b such that $-\mu'(\tilde{S}_2(\tau)) \in [a, b]$ for any $\tau > T$. The following inequality is obtained

$$\int_T^{+\infty} (\mu(S_2(\tau)) - \rho D) d\tau \geq a \int_T^{+\infty} X_2(\tau) d\tau - \frac{b}{\rho D} |Z_2(T)|$$

leading to a contradiction with (97). \square

References

- [1] J.F. ANDREWS, A mathematical model for the continuous culture of microorganisms utilizing inhibitory substrates, *Biotech. Bioeng.*, 10, 707–723, 1968.
- [2] A. BERMAN AND J. PLEMMONS, *Nonnegative Matrices in the Mathematical Sciences*. Academic Press, New-York, 1979.
- [3] M. CRESPO AND A. RAPAPORT, About the chemostat model with a lateral diffusive compartment *preprint arXiv* 1711.09634, 2018.
- [4] J.R. DE DREUZY, A. RAPAPORT, T. BABEY AND J. HARMAND, Influence of porosity structures on mixing-induced reactivity at chemical equilibrium in mobile/immobile Multi-Rate Mass Transfer (MRMT) and Multiple INTERacting Continua (MINC) models, *Water Resources Research*, 49, 1–19, 2013.
- [5] D. FIFE, Which linear compartmental systems contain trap? *Math. Biosci.* 14, pp.311-315, 1972.
- [6] S. FOGER, *Elements of Chemical Reaction Engineering*, 4th edition. Prentice Hall, New-York, 2008.
- [7] C. DE GOOIJER, W. BAKKER, H. BEEFTINK AND J. TRAMPER, Bioreactors in series: an overview of design procedures and practical applications. *Enzyme Microb. Technol.* 18, pp. 202–219, 1996.
- [8] J.L. GOUZÉ, Positive and negative circuits in dynamical systems. *J. Biol. Systems.* 6(1), pp.11–15, 1998.
- [9] I. HAIDAR, A. RAPAPORT, A. AND F. GÉRARD, Effects of spatial structure and diffusion on the performances of the chemostat. *Mathematical Bioscience and Engineering.* 8(4), pp. 953–971, 2011.
- [10] J. HARMAND AND D. DOCHAIN, The optimal design of two interconnected (bio)chemical reactors revisited. *Comput. Chem. Eng.* 30, pp. 70–82, 2005.
- [11] J. HARMAND, C. LOBRY, A. RAPAPORT AND T. SARI, *The Chemostat: Mathematical Theory of Micro-organisms Cultures*, Chemical Engineering Series, Wiley, 2017.
- [12] J. HARMAND, A. RAPAPORT AND A. TROFINO, Optimal design of two interconnected bioreactors—some new results. *AIChE J.* 49(6), pp. 1433–1450, 1999.
- [13] M. HIRSCH AND H. SMITH, Competitive and Cooperative Systems: a mini-review, *POSTA 2003: Positive systems, Lecture notes in control and information sciences*, 294, Springer, pp. 183-190, 2003.
- [14] J. JACQUEZ AND C. SIMON, Qualitative theory of compartmental systems. *SIAM Review*, 35(1), pp. 43–79, 1993.
- [15] Z. KONKOLI, Interplay between chemical reactions and transport in structured spaces, *Physical Review E.* 72 (1), pp. 011917.1-9, 2005.
- [16] Z. KONKOLI, Diffusion-controlled reactions in small and structured spaces as a tool for describing living cell biochemistry, *J. Phys.: Condens. Matter* 19, 065149, 2007.
- [17] O. LEVENSPIEL, *Chemical reaction engineering*, 3rd edition. Wiley, New York, 1999.
- [18] R. W. LOVITT AND J.W.T. WIMPENNY, The gradostat: a tool for investigating microbial growth and interactions in solute gradients. *Soc. Gen. Microbial Quart.* 6, 80, 1979.

- [19] R. W. LOVITT AND J.W.T. WIMPENNY, The gradostat: a bidirectional compound chemostat and its applications in microbiological research, *J. Gen. Microbiol.* 127, 261–268, 1981.
- [20] K. LUYBEN AND J. TRAMPER, Optimal design for continuously stirred tank reactors in series using Michaelis-Menten kinetics. *Biotechnol. Bioeng.* 24, pp. 1217–1220, 1982.
- [21] M. MISCHAIKOW, H. SMITH AND H. THIEME, Asymptotically autonomous semiflows: chain recurrence and Lyapunov functions, *Transactions of the American Mathematical Society*, 347(5), 1669–1685, 1995.
- [22] H. NAKAO AND A. MIKHAILOV, Turing patterns in network-organized activator-inhibitor systems *Nature Physics* 6, pp. 544–550, 2010.
- [23] S. NAKAOKA AND Y. TAKEUCHI, Competition in chemostat-type equations with two habitats. *Math. Biosci.* 201, 157–171 (2006).
- [24] E. NAUMAN, *Chemical Reactor Design, Optimization, and Scale up*, McGraw-Hill Handbooks Series, 2002.
- [25] M. NELSON AND H. SIDHU, Evaluating the performance of a cascade of two bioreactors. *Chem. Eng. Sci.* 61, pp. 3159–3166, 2006.
- [26] A. RAPAPORT, I. HAIDAR AND J. HARMAND, Global dynamics of the buffered chemostat for a general class of growth functions, *J. Mathematical Biology*, 71(1), pp. 69–98, 2015.
- [27] A. RAPAPORT, A. ROJAS-PALMA, J.R.. DE DREUZY AND H. RAMIREZ, Equivalence of finite dimensional input-output models of solute transport and diffusion in geoscience, *IEEE Transactions on Automatic Control*, 62 (10), pp. 5470–5477, 2017.
- [28] R. SCHWARTZ, A. JUO AND K. MCINNES, Estimating parameters for a dual-porosity model to describe non-equilibrium, reactive transport in a fine-textured soil. *J. Hydrol.* 229(3–4), pp. 149–167, 2000.
- [29] H. SMITH, Cooperative systems of differential equations with concave nonlinearities. *Non-linear Analysis, Theory and Applications: methods and Applications* 10 (10), pp. 1037–1052, 1986.
- [30] H. SMITH, The gradostat: A model of competition along a nutrient gradient. *Microbial Ecology*, 22(1), pp. 207–26, 1991.
- [31] H. SMITH, Monotone dynamical systems: Reflections on new advances & applications. *Discrete & Continuous Dynamical Systems - A*, 37 (1), 485–504, 2017.
- [32] H. SMITH AND P. WALTMAN, *The Theory of the Chemostat, Dynamics of Microbial Competition*. Cambridge University Press, 1995.
- [33] G. STEPHANOPOULOS AND A. G. FREDRICKSON, Effect of inhomogeneities on the coexistence of competing microbial populations, *Biotechnology and Bioengineering* 21, pp. 1491–1498, 1979.
- [34] B. TANG, Mathematical investigations of growth of microorganisms in the gradostat, *J. Math. Biol.*, 23, pp. 319–339, 1986.
- [35] C. TSAKIROGLOU AND M. IOANNIDIS, Dual-porosity modelling of the pore structure and transport properties of a contaminated soil. *Eur. J. Soil Sci.* 59(4), pp. 744–761, 2008.
- [36] J. ZAMBRANO, B. CARLSSON AND S. DIEHL, Optimal steady-state design of zone volumes of bioreactors with Monod growth kinetics. *Biochem. Eng. J.* 100, pp. 59–66, 2015.