



**HAL**  
open science

# Robust optimization : formulation, kriging and evolutionary approaches

Rodolphe Le Riche

► **To cite this version:**

Rodolphe Le Riche. Robust optimization : formulation, kriging and evolutionary approaches. Doctoral. France. 2014. cel-01081293

**HAL Id: cel-01081293**

**<https://hal.science/cel-01081293v1>**

Submitted on 7 Nov 2014

**HAL** is a multi-disciplinary open access archive for the deposit and dissemination of scientific research documents, whether they are published or not. The documents may come from teaching and research institutions in France or abroad, or from public or private research centers.

L'archive ouverte pluridisciplinaire **HAL**, est destinée au dépôt et à la diffusion de documents scientifiques de niveau recherche, publiés ou non, émanant des établissements d'enseignement et de recherche français ou étrangers, des laboratoires publics ou privés.

---

# **Robust optimization : formulation, kriging and evolutionary approaches**

Rodolphe Le Riche  
CNRS and Ecole des Mines de Saint-Etienne

class given as part of the “Modeling and Numerical Methods for  
Uncertainty Quantification” French-German summer school, Porquerolles,  
Sept. 2014

---

# Outline of the talk

---

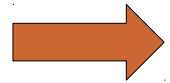

1. Motivations for robust optimization
2. Formulations of optimization problems with uncertainties
3. Kriging-based approaches (costly functions)
4. Evolutionary approaches (non costly functions)

# Why do we optimize ?

---

Optimization as a mathematical formulation for decision

$$\begin{aligned} \min_{x \in S} f(x) \\ g(x) \leq 0 \end{aligned}$$

followed by a numerical, approximate, resolution,

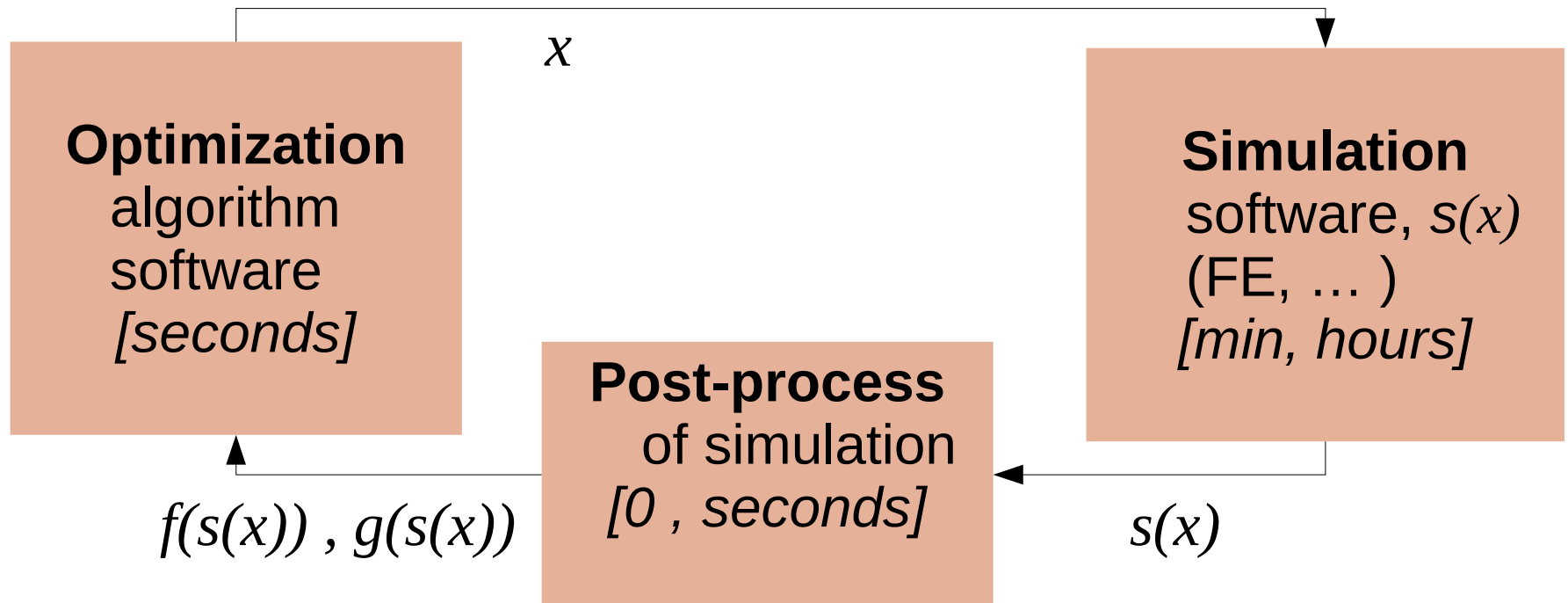

Communication between programs by file, pipe, messages, ...

---

# Motivations for robust optimization

---

What is the point – in practice – for deterministically solving an optimization problem when there are

- unstable optima
- aleatory model (  $s$  ) parameters
- model uncertainties
- dynamically changing model conditions (complex systems)

???

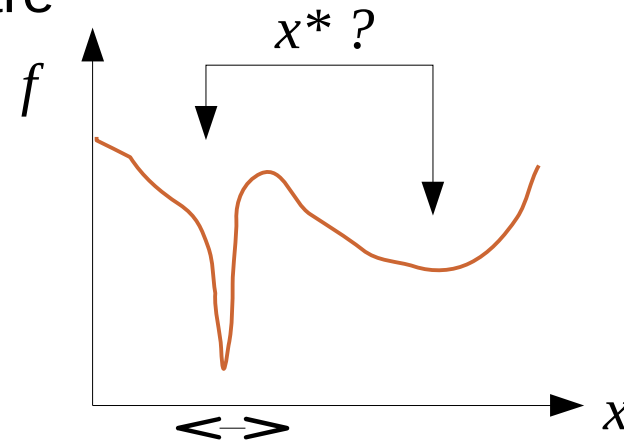

# Unstable deterministic optimum. Expl of an air duct.

Minimize pressure loss by changing the (parameterized) shape.

## deterministic design

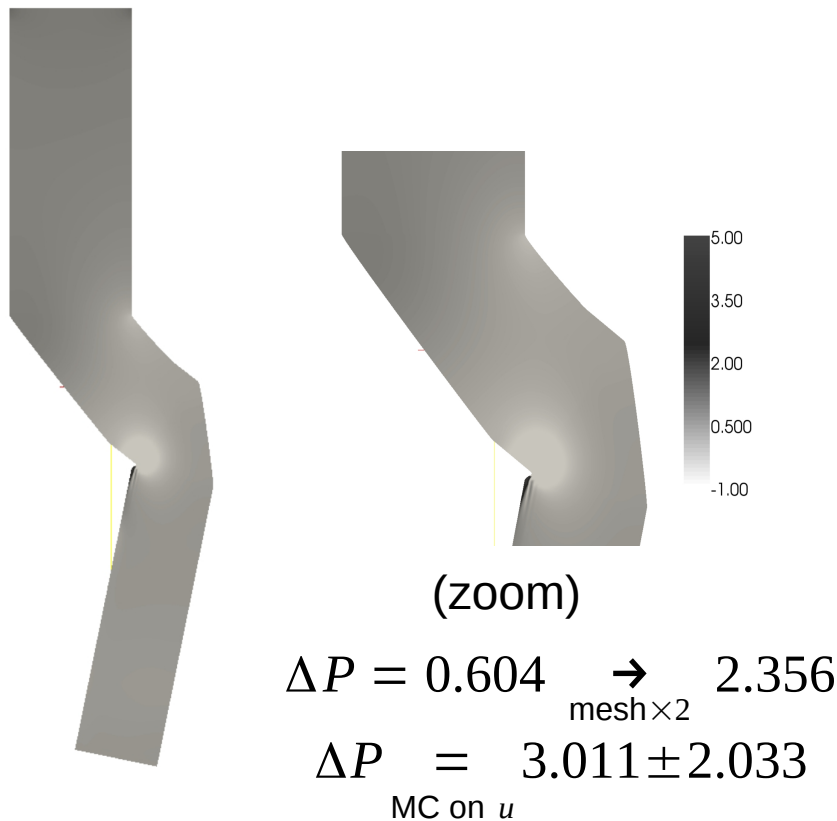

## robust design

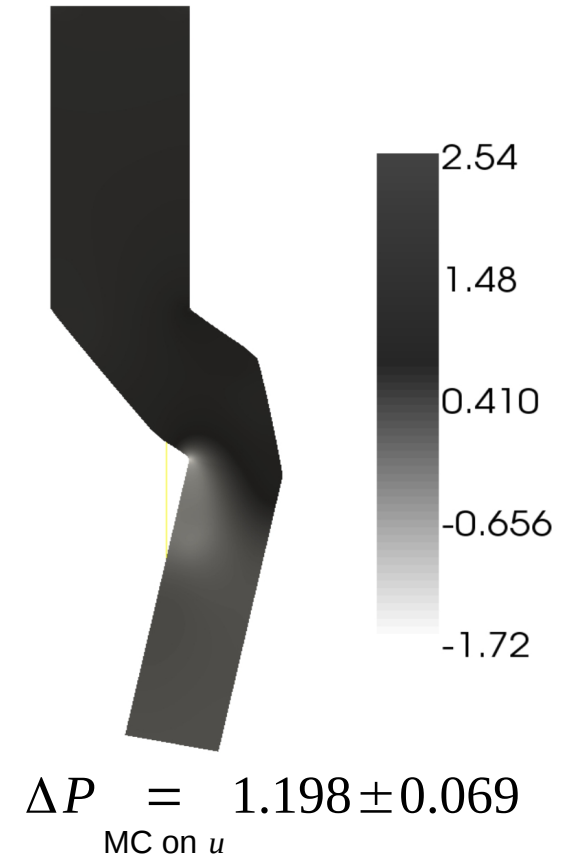

The optimization exploits meshing flaws.  
The result is not stable w.r.t. mesh or boundary conditions changes.

Cf. J. Janusevskis and R. Le Riche, *Robust optimization of a 2D air conditioning duct using kriging*, technical report hal-00566285, feb. 2011.

# Unstable deterministic optimum. Expl of a combustion engine.

---

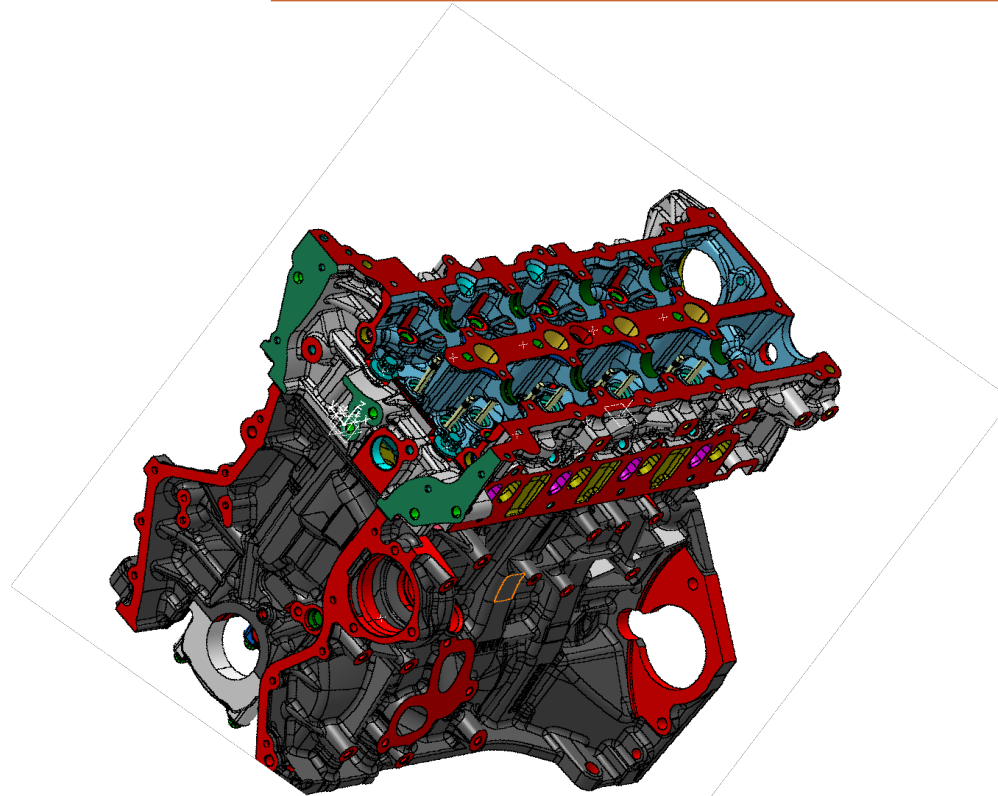

a +/- 1mm dispersion in the manufacturing of a car cylinder head can degrade its performance (g CO<sub>2</sub>/km) by -20% (worst case)

# Motivations for robust optimization

---

What is the point – in practice – for deterministically solving an optimization problem when there are

- unstable optima
- aleatory model ( s ) parameters
- model uncertainties
- dynamically changing model conditions (complex systems)

???

→ **modify the problem statement, therefore also the optimization algorithms** → **robust optimization**



# Outline of the talk

---

1. Motivations for robust optimization



2. Formulations of optimization problems with uncertainties

3. Kriging-based approaches (costly functions)

4. Evolutionary approaches (non costly functions)

---

# Formulations of optimization problems under uncertainties

H.G. Beyer, B. Sendhoff, Robust Optimization – A comprehensive survey, Comput. Methods Appl. Mech. Engrg, 196, pp. 3190-3218, 2007.

G. Pujol, R. Le Riche, O. Roustant and X. Bay, *L'incertitude en conception: formalisation, estimation*, Chapter 3 of the book *Optimisation Multidisciplinaire en Mécaniques : réduction de modèles, robustesse, fiabilité, réalisations logicielles*, Hermes, 2009 (in French ;-( )

---

## Formulation of optimization under uncertainty

# The double (x,U) parameterization

We introduce  $U$ , a vector of uncertain (random) parameters that affect the simulator  $s$ .

$x$  is a vector of deterministic optimization (controlled) variables.  $x$  in  $S$ , the search space.

(cf. Taguchi, 80's)

$s(x) \rightarrow s(x,U)$  , therefore  $f(x) \rightarrow f(s(x,U)) = f(x,U)$   
and  $g(x) \rightarrow g(s(x,U)) = g(x)$

$U$  used to describe

- noise (as in identification with measurement noise)
- model error (epistemic uncertainty)
- uncertainties on the values of some parameters of  $s$ .

# Formulation of optimization under uncertainty

## The $(x,U)$ parameterization is general

Three cases (which can be combined)

Expl :  $f(.) \equiv s(.) \equiv \sigma(R,L)$  (radial stress)

### 1. Noisy controlled variables

Expl : manufacturing tolerance,

$$R \equiv x+U \quad , \quad f(x,U) \equiv \sigma(x+U,L)$$

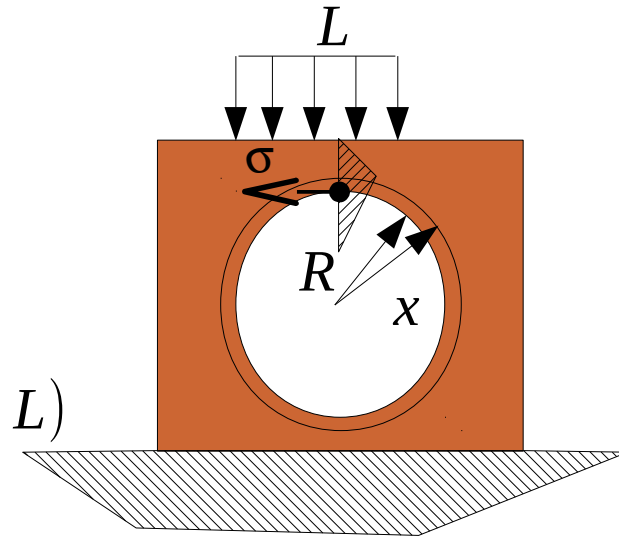

### 2. Noise exogenous to the optimization variables

Expl : random load  $L+U$ ,  $x$  is a dimension.

$$f(x,U) \equiv \sigma(x,L+U)$$

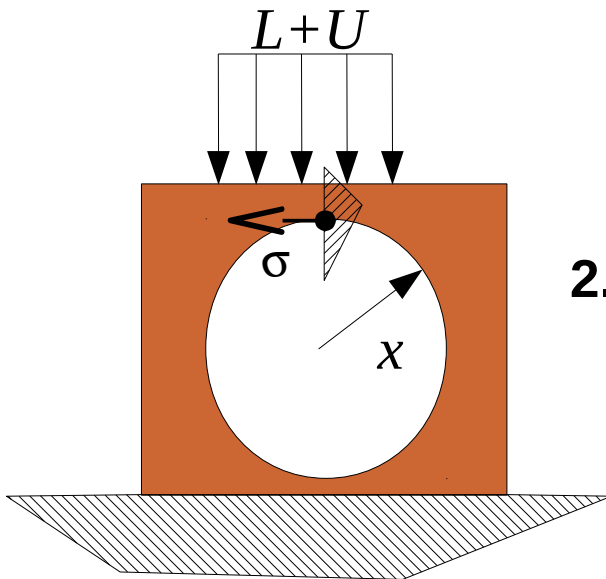

### 3. Noise as an error model for the simulation

$$\text{Expl. : } f(x,U) \equiv \sigma(x,L)+U$$

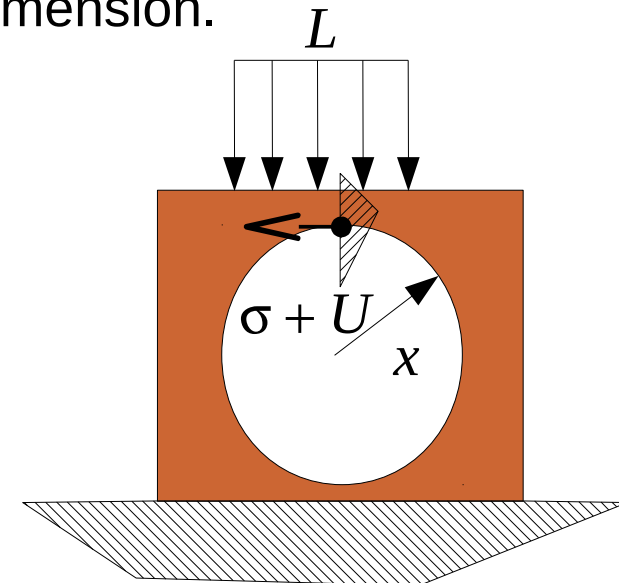

# Formulation of optimization under uncertainties (1) the noisy case

---

Let's not do anything about the uncertainties, i.e., try to solve

$$\begin{aligned} \min_{x \in S \subset \mathbb{R}^d} \quad & f(x, U) \\ & g(x, U) \leq 0 \end{aligned}$$

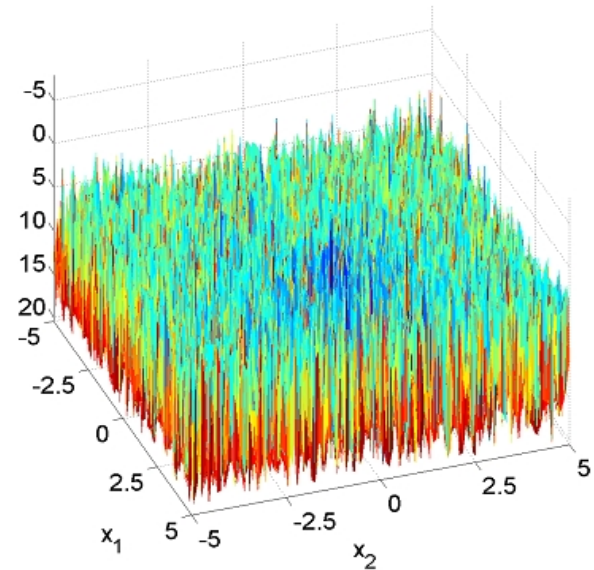

It does not look good : gradients are not defined, what is the result of the optimization ?

But sometimes there is no other choice. Ex :  $y$  expensive with uncontrolled random numbers inside (like a Monte Carlo statistical estimation, numerical errors, measured input).

## Formulation of optimization under uncertainties (2) an ideal series formulation

---

Replace the noisy optimization criteria by statistical measures

$G(x)$  is the random event "all constraints are satisfied" ,

$$G(x) = \bigcap_i \{g_i(x, U) \leq 0\}$$

$$\begin{aligned} \min_{x \in S} q_\alpha^c(x) \quad & \text{(conditional quantile)} \\ \text{such that } P(G(x)) & \geq 1 - \varepsilon \end{aligned}$$

where the conditional quantile is defined by

$$P(f(x, U) \leq q_\alpha^c(x) \mid G(x)) = \alpha$$

## Formulation of optimization under uncertainties

### (3) simplified formulations often seen in practice

---

For bad reasons (joint probabilities ignored) or good ones (simpler numerical methods – Gaussian pdf – , lack of data, organization issues), quantiles are often replaced by averages and variances, conditioning is neglected, constraints are handled independently :

$$\min_{x \in S} q_\alpha(x) \quad \text{or} \quad \min_{x \in S} E(f(x, U)) \quad \text{and / or} \quad \min_{x \in S} V(f(x, U))$$

$$\text{or} \quad \min_{x \in S} E(f(x, U)) + r \sqrt{V(f(x, U))}$$

$$\text{where} \quad P(f(x, U) \leq q_\alpha(x)) = \alpha \quad \text{and} \quad r > 0$$

$$\text{such that} \quad P(G(x)) \geq 1 - \varepsilon \quad \text{or} \quad P(g_i(x) \leq 0) \geq 1 - \varepsilon_i$$

where  $\varepsilon$  is the series system risk  
and  $\varepsilon_i$  is the  $i$ th failure mode risk

---

# Formulation of optimization under uncertainties

## Direct approaches (1/4)

---

In practice, statistical performance measures are estimated

$$\hat{f}(x) = \left\{ \widehat{E}_U(f(x, U)) \text{ or } \widehat{E}_U(f(x, U)) + r \sqrt{\widehat{V}_U(f(x, U))} \text{ or } \widehat{E}_U q_\alpha(x) \right\}$$

Crude Monte Carlo expl :

$$\hat{f}(x) = \widehat{E}_U(f(x, U)) = \frac{1}{MC} \sum_{i=1}^{MC} f(x, u^i), \quad u^i \text{ i.i.d. } \sim U$$

$$\hat{f}(x) = \widehat{E}_U q_\alpha(x) = [MC \times \alpha]\text{-th lowest among } f(x, u^1), \dots, f(x, u^{MC})$$

$\hat{g}(x) = \dots$  (cf. reliability estimation classes)



## Formulation of optimization under uncertainties

# Direct approaches (2/4)

---

Direct (naive) approaches to optimization with uncertainties have a **double loop** : propagate uncertainties on  $U$ , optimize on  $x$ .

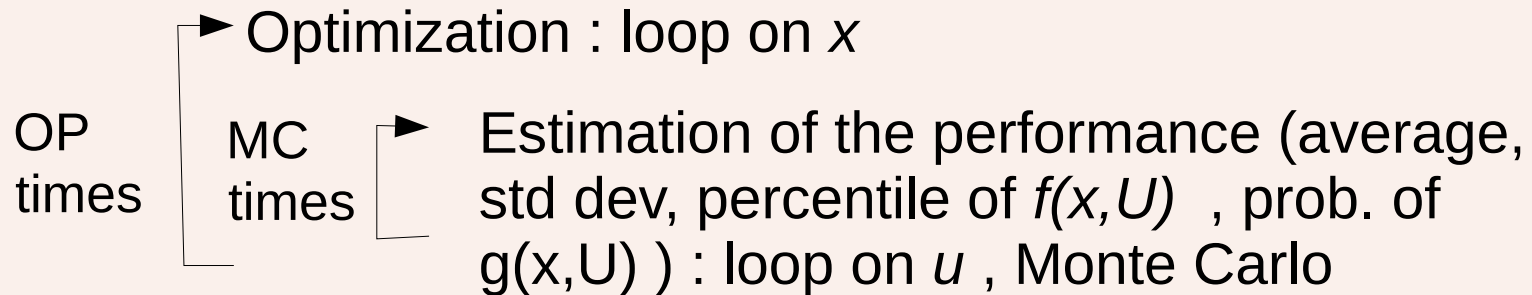

Such a double loop is **very costly** : Total cost =  $OP \times MC$   
( calls to  $s$  )

# Formulation of optimization under uncertainties

## Direct approaches (3/4)

---

Most local (e.g., gradient based) optimizers will show poor convergence with noisy statistical estimators (e.g., crude Monte Carlo).

Ex : quasi-Newton method with finite differences

little noise

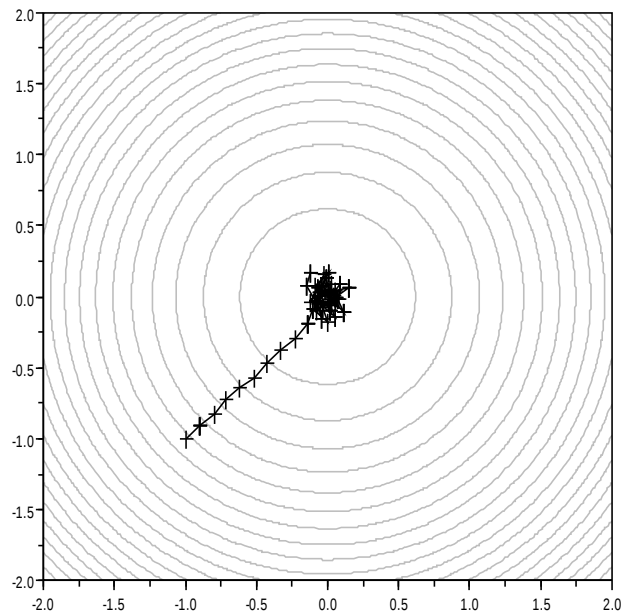

more noise

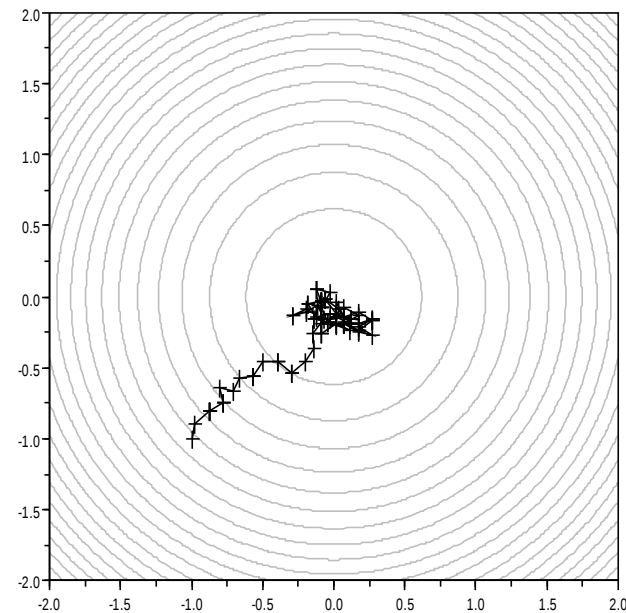

$$\hat{f}(x) = \frac{1}{100} \sum_{i=1}^{100} \|x + u_i\|^2$$

$$u_i \sim N(0, I_2)$$

$$\hat{f}(x) = \|x + u_i\|^2$$

# Formulation of optimization under uncertainties

## Direct approaches (4/4)

---

Avoid noisy statistical estimators with **common random numbers**

Expl :  $\hat{f}(x) = \frac{1}{MC} \sum_{i=1}^{MC} f(x, u^i)$  has same regularity as  $f$  for given  $u^i$ 's

see Bruno  
Tuffin's class on  
sampling (quasi  
Monte Carlo)

Sample  $\{u^1, \dots, u^{MC}\}$  according to  $U$

once for  
all before  
the loops

```
for i=1:OP
  optimizer(past x,  $\hat{f}(x)$ ) → new x
  for j=1:MC
     $\hat{f}(x) \leftarrow \hat{f}(x) + f(x, u^i)$ 
  end
   $\hat{f}(x) \leftarrow \hat{f}(x) / MC$ 
end
```

But,

- does not solve the cost issue
- (less critically) the estimates  $\hat{f}(x^1), \dots, \hat{f}(x^{OP})$  depend on the choice of  $u^1, \dots, u^{MC}$

# Outline of the talk

---

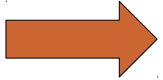
1. Motivations for robust optimization
2. Formulations of optimization problems with uncertainties
-  3. Kriging-based approaches (costly functions)
4. Evolutionary approaches (non costly functions)

## Unconstrained continuous optimization

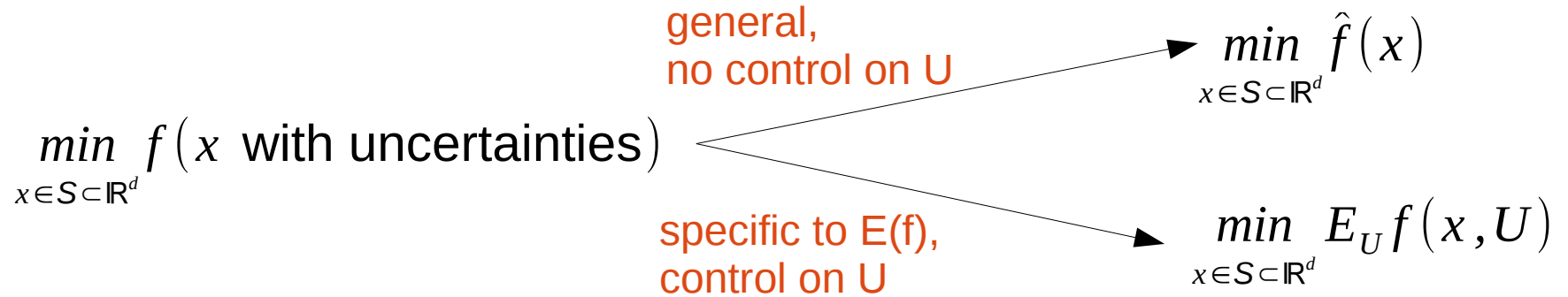

[ Constraints,  $g(x) \leq 0$ , are not explicitly discussed in this talk. As a patch, you may assume that

$$\begin{array}{l}
 \min_{x \in S \subset \mathbb{R}^d} f(x) \\
 g(x) \leq 0
 \end{array}
 \rightarrow
 \min_{x \in S \subset \mathbb{R}^d} f(x) + p \times \max^2(0, g(x))$$

Constraints satisfaction problem : A. Chaudhuri, R. Le Riche and M. Meunier, *Estimating feasibility using multiple surrogates and ROC curves*, 54th AIAA SDM Conference, Boston, USA, 8-11 April 2013. ]

## Unconstrained continuous optimization **of costly functions**

~ 20 to 1000 calls possible,  $d = 1$  to 20

---

# Kriging with noisy observations (1/5)

$$Y(x) = \mu(x) + Z(x) + E(x)$$

$\hat{f}(x)$   
here

where  $Z(x) \sim N(0, C(x, x))$  and  $E(x) \sim N(0, \tau_x^2)$   
 $Z(x) \perp E(x')$

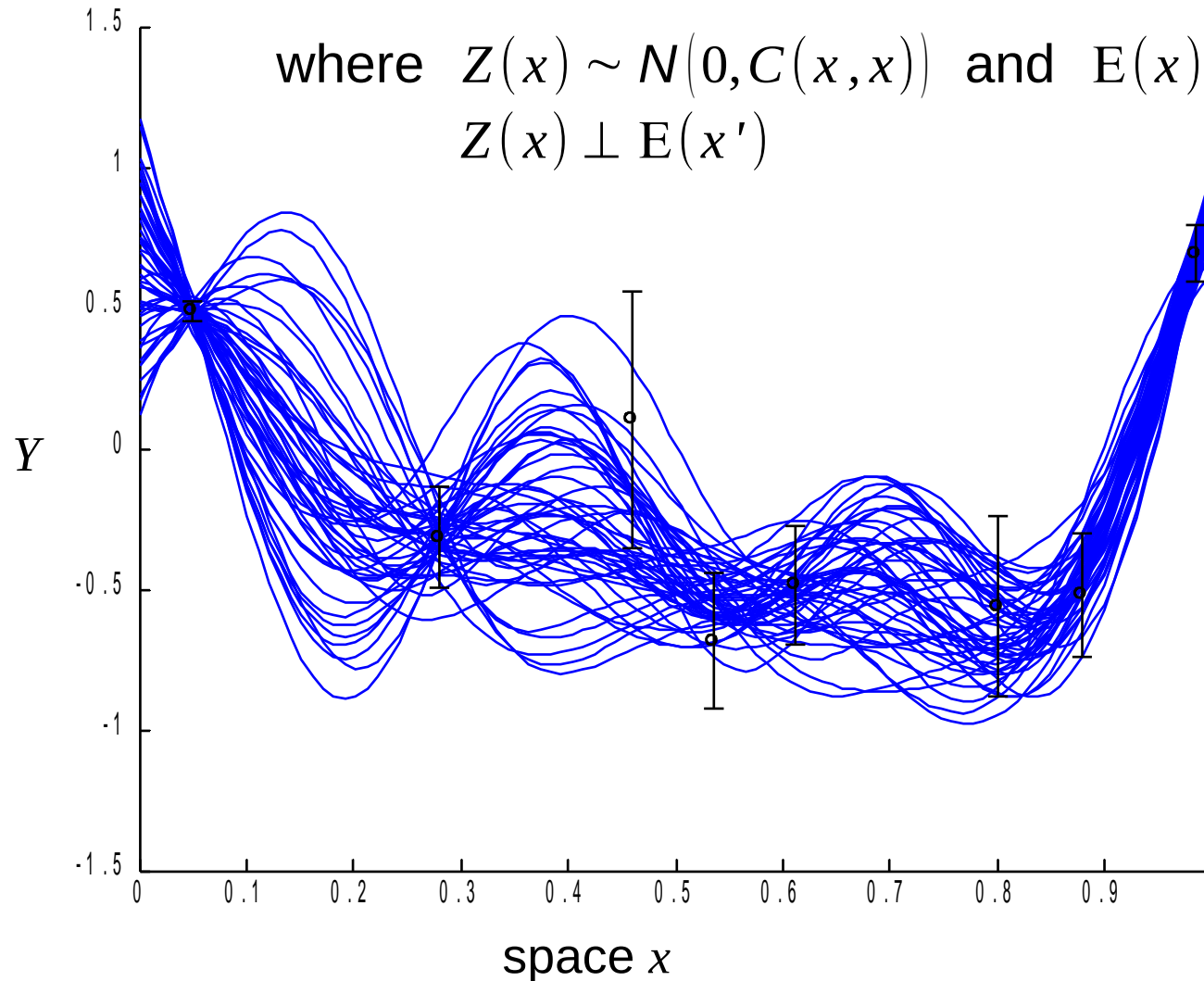

kriging-based approaches

# Kriging with noisy observations (2/5)

---

Apply the conditioning result to the vector

$$\begin{bmatrix} Z(x^*) + \mu(x^*) \\ Y(x^1) \\ \vdots \\ Y(x^n) \end{bmatrix} = \begin{bmatrix} Z(x^*) + \mu(x^*) \\ \boldsymbol{\mu} + \mathbf{Z} + \mathbf{E} \end{bmatrix} \sim N \left( \begin{bmatrix} \mu(x^*) \\ \boldsymbol{\mu} \end{bmatrix}, \begin{bmatrix} \sigma^2 & C(x^*, \mathbf{X}) \\ C(x^*, \mathbf{X})^T & \mathbf{C} + \text{diag}(\boldsymbol{\tau}^2) \end{bmatrix} \right)$$

because  $\text{Cov}(Y(x^i), Y(x^j)) = E((\mu^i + Z^i + E^i - \mu^i)(\mu^j + Z^j + E^j - \mu^j)) = C_{ij} + \delta_{ij} \tau_i^2$

The only change w.r.t. the usual kriging formula is the addition of the observation variances on the covariance diagonal

$$(Z(x^*) + \mu(x^*)) | \mathbf{Y} = \mathbf{y} \sim N(m_{SK}(x^*), v_{SK}(x^*))$$

$$m_{SK}(x^*) = \mu(x^*) + C(x^*, \mathbf{X})(\mathbf{C} + \text{diag}(\boldsymbol{\tau}^2))^{-1}(\mathbf{y} - \boldsymbol{\mu})$$

$$v_{SK}(x^*) = \sigma^2 - C(x^*, \mathbf{X})(\mathbf{C} + \text{diag}(\boldsymbol{\tau}^2))^{-1}C(x^*, \mathbf{X})^T$$

# kriging-based approaches

## Kriging with noisy observations (3/5)

---

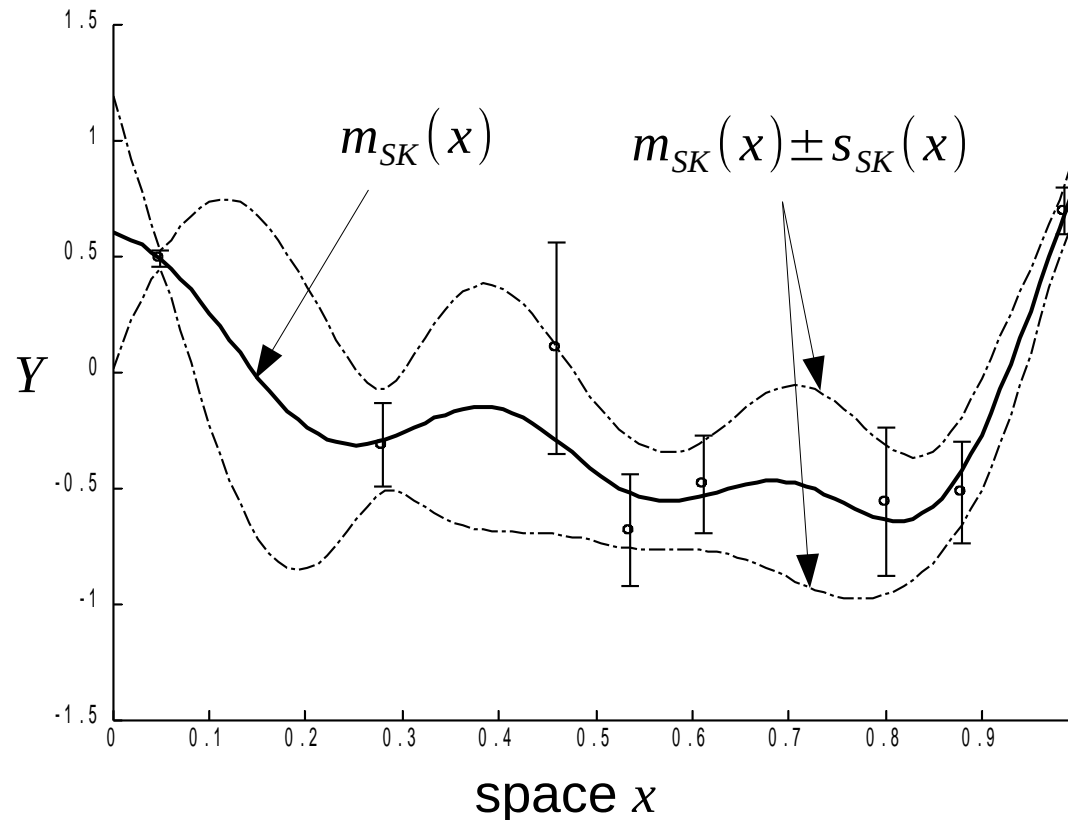

- **kriging no longer interpolating**
- **the kriging mean filters the noise**
- additive covariance diagonal terms called « nugget effect »
- often used as a regularization technique in non noisy situations
  
- kriging = our approach to link  $x$  and  $U$  spaces in optimization



# kriging-based approaches

## Kriging with noisy observations (4/5)

---

In the context of robust optimization with MC estimators, the observation noise can be set as

$$\tau_i^2 = \text{variance of performance estimate, } \hat{f}(\cdot), \text{ at } x^i$$

Expl.: mean estimate has variance

$$\tau_i^2 = V(\hat{f}(x^i)) = \frac{1}{MC(MC-1)} \sum_{j=1}^{MC} (f(x, u^j) - \hat{f}(x))^2$$

( Expl. with quantile estimate, cf. Le Riche et al., *Gears design with shape uncertainties using Monte Carlo simulations and kriging*, SDM, AIAA-2009-2257 )

# Kriging with noisy observations (5/5)

---

The hyperparameters can be tuned through max likelihood, 2 cases

## Known (from context) heterogeneous noise

$$\mathbf{C}_\tau \equiv \mathbf{C} + \text{diag}(\tau_1^2, \dots, \tau_n^2) \quad , \quad \mathbf{C}_\tau \equiv \sigma^2 \mathbf{R}_\tau$$

and do the usual MLE estimation (cf. ``intro. to kriging class")

replacing  $\mathbf{R}$  by  $\mathbf{R}_\tau \rightarrow \hat{\sigma} , \hat{\theta}_1 , \dots , \hat{\theta}_n$

## Unknown homogeneous noise

$$\mathbf{C}_\tau \equiv \mathbf{C} + \tau^2 \mathbf{I} \quad , \quad \mathbf{C}_\tau \equiv \sigma^2 \mathbf{R}_\tau$$

and do the usual MLE estimation replacing  $\mathbf{R}$  by  $\mathbf{R}_\tau$

(1 additional parameter in the concentrated likelihood,  $\tau$ )

$\rightarrow \hat{\tau} , \hat{\sigma} , \hat{\theta}_1 , \dots , \hat{\theta}_n$

# kriging-based approaches

---

We have seen

- how to formulate a robust optimization problem
- how to model noisy observations with kriging
- but how to optimize when a kriging metamodel is built ?

# Kriging-based approaches

## Kriging prediction minimization

The simplest (naive) approach.

For  $t=1, t^{max}$  do,

Learn  $Y^t(x)$  ( $m_K$  and  $s_K^2$ ) from  $f(x^1), \dots, f(x^t)$

$x^{t+1} = \min_x m_K(x)$

Calculate  $f(x^{t+1})$

$t = t+1$

End For

e.g., using CMA-ES\*  
if multimodal  
\* Hansen et al., 2003

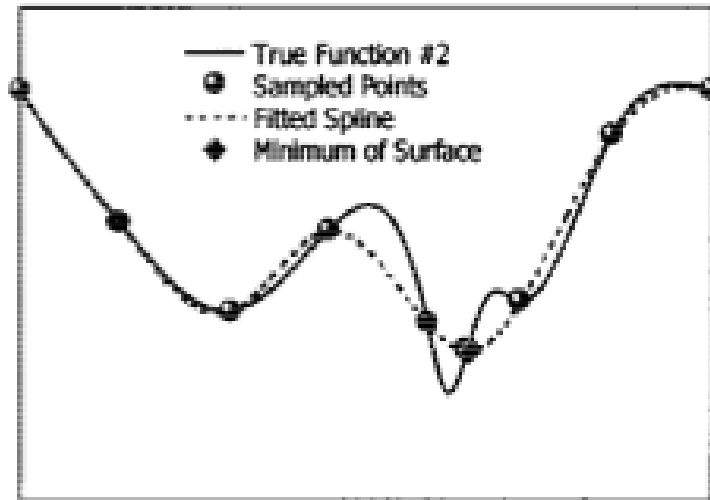

But it may fail if  $m_K(x^{t+1}) = f(x^{t+1})$  :  
the minimizer of  $m_K$  is at a data point  
which may not even be a local optimum.

D. Jones, A taxonomy of global optimization methods  
based on response surfaces, JOGO, 2001.

Notation : this slide + the ones coming about EGO are general to any optimization,  
therefore  $\hat{f} \rightarrow f$

# kriging-based approaches

## Kriging and optimization

---

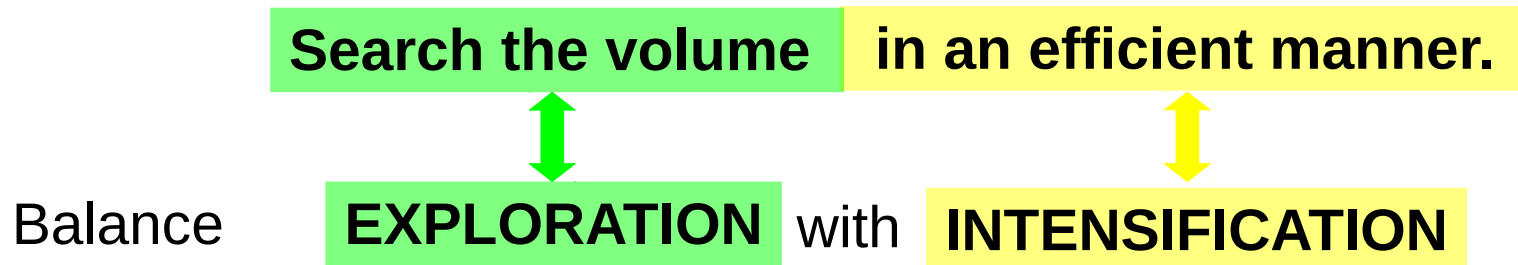

- We will deterministically fill the design space in an efficient order.
  - Other global search principles
    - **Stochastic searches** : (pseudo)-randomly sample the design space  $S$ , use probabilities to intensify search in known high performance regions and sometimes explore unknown regions.
    - (pseudo-)Randomly restart local searches.
    - (and mix the above principles)
-

kriging-based approaches

# A state-of-the-art global optimization algorithm using metamodels : EGO

---

(D.R. Jones et al., JOGO, 1998)

EGO = Efficient Global Optimization = use a « kriging » metamodel to define the Expected Improvement (EI) criterion. Maximize EI to create new  $x$ 's to simulate.

EGO deterministically creates a series of design points that ultimately would fill  $S$ .

Some opensource implementations :

- DiceOptim in R (EMSE & Bern Univ.)
  - Krisp in Scilab (Riga Techn. Univ & EMSE)
  - STK: a Small (Matlab/GNU Octave) Toolbox for Kriging, (Supelec)
-

# kriging-based approaches (one point-) Expected improvement

A natural measure of progress : the improvement,

$$I(x) = [f_{\min} - F(x)]^+ \mid F(x) = f(x) \quad , \quad \text{where } [.]^+ \equiv \max(0, .)$$

- The expected improvement is known analytically.
- It is a parameter free measure of the exploration-intensification compromise.
- Its maximization defines the EGO deterministic global optimization algorithm.

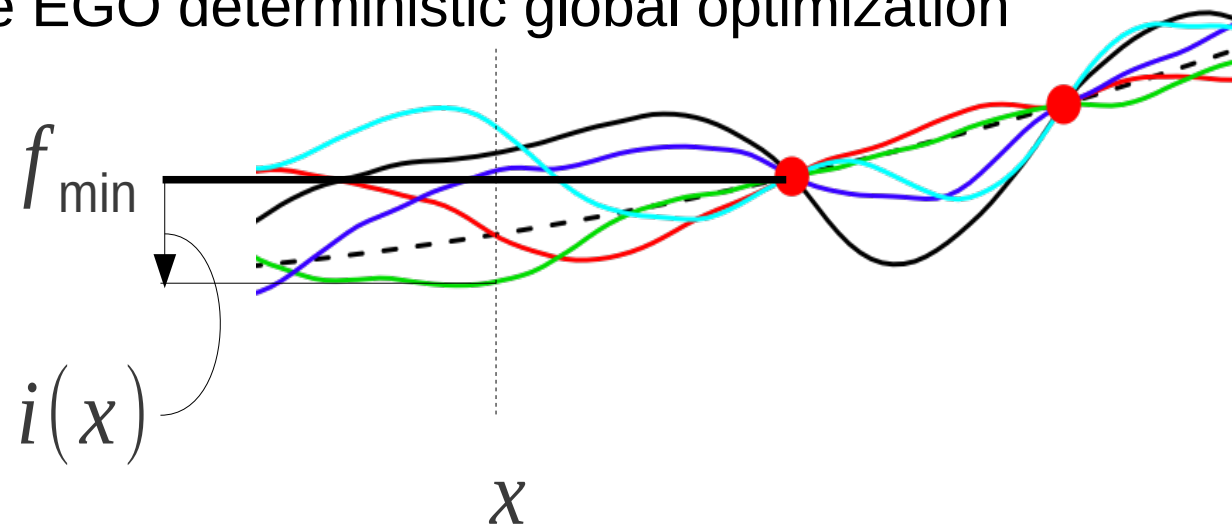

$$EI(x) = \sqrt{v_K(x)} \times (u(x)\Phi(u(x)) + \varphi(u(x))) \quad , \quad \text{where } u(x) = \frac{f_{\min} - m_K(x)}{\sqrt{v_K(x)}}$$

# kriging-based approaches

## One EGO iteration

---

At each iteration, EGO adds to the  $t$  known points the one that maximizes EI,

$$x^{t+1} = \arg \max_x EI(x)$$

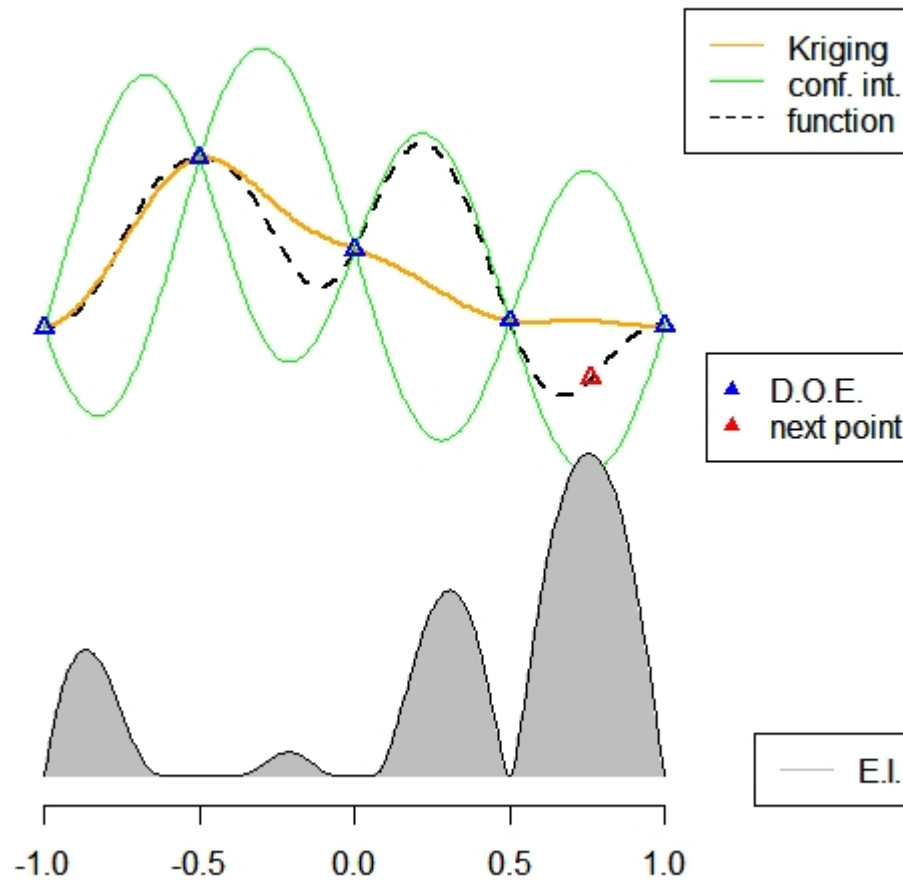

then, the kriging model is updated ...

---



# kriging-based approaches

## EGO : example

---

iteration  
1

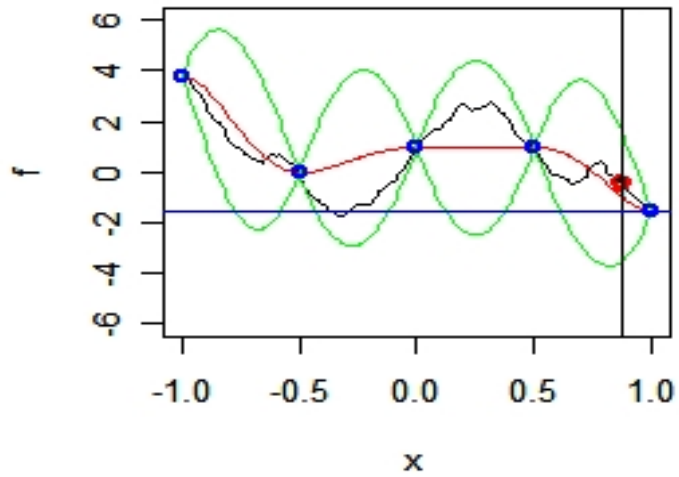

iteration  
2

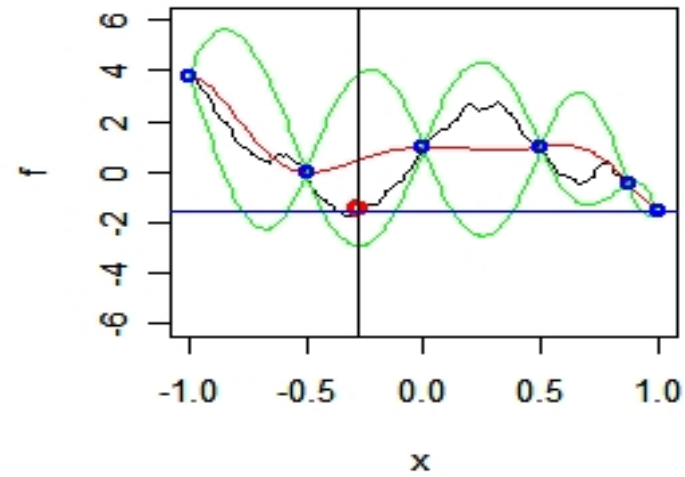

iteration  
3

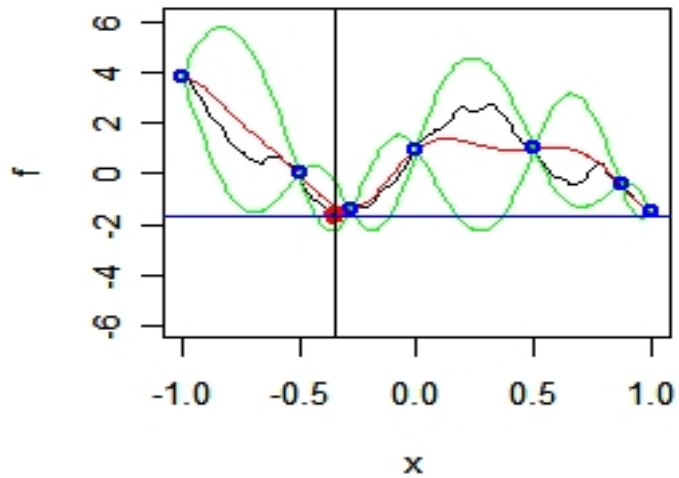

iteration  
4

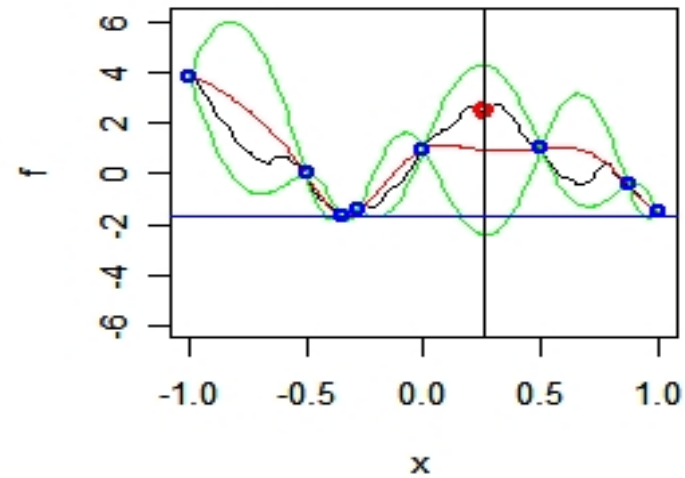

# kriging-based approaches

## EGO : 6D example

Hartman function,  $f(x^*) = -3.32$ , 10 points in initial DoE

Séquence des valeurs observées durant EGO

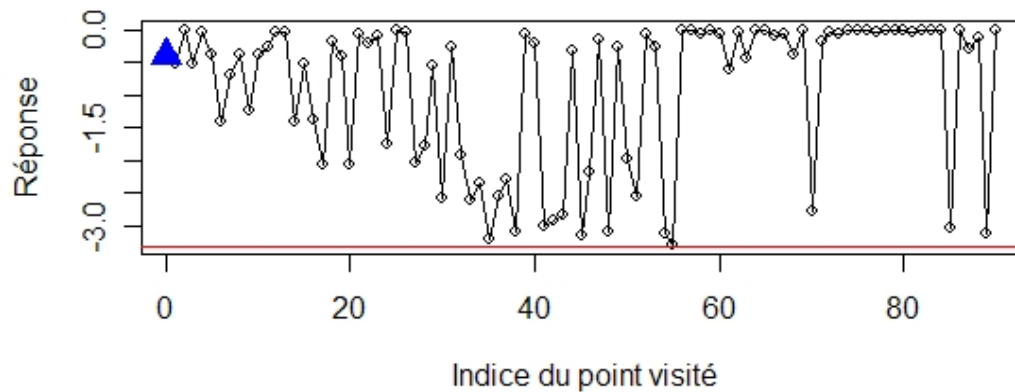

Séquence du minimum courant durant EGO

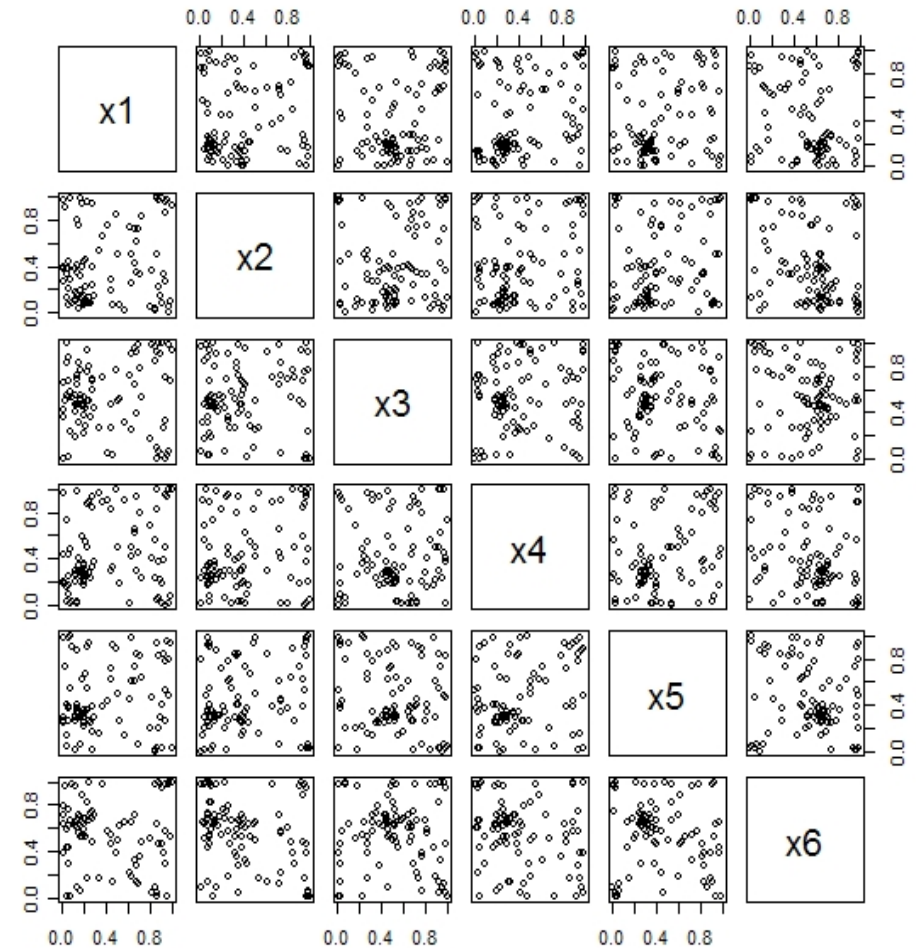
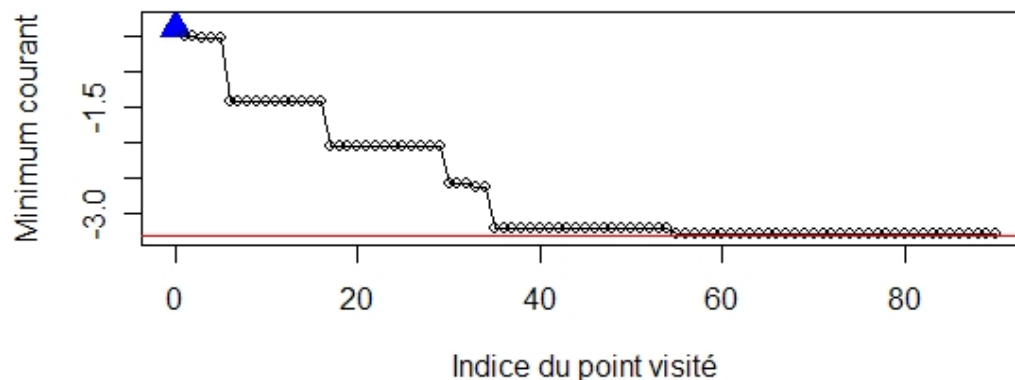

(DiceOptim, D. Ginsbourger, 2009)

# Outline of the talk

---

1. Motivations for robust optimization
2. Formulations of optimization problems with uncertainties
3. Kriging-based approaches to robust optimization (costly functions)
  - Kriging noisy observations
  - Optimization and kriging
  -  Robust optimization, no control on U
  - Robust optimization, control on U
4. Evolutionary approaches (non costly functions)

# Kriging-based robust optimization, no control on U

## EI for noisy functions

**EI should not be used for noisy observations** because  $\hat{f}_{min} \equiv y_{min}$  is noisy ! (a low  $y_{min}$  would mislead EGO for a long time)

**Solution 1** : Add nugget effect and replace  $y_{min}$  by the best observed mean (filters out noise in already sampled regions) :

$$EI^{noisy}(x) = E \left[ \max \left( \min_{i=1,t} m_K(x^i) - (Z(x) + \mu(x)), 0 \right) \right]$$

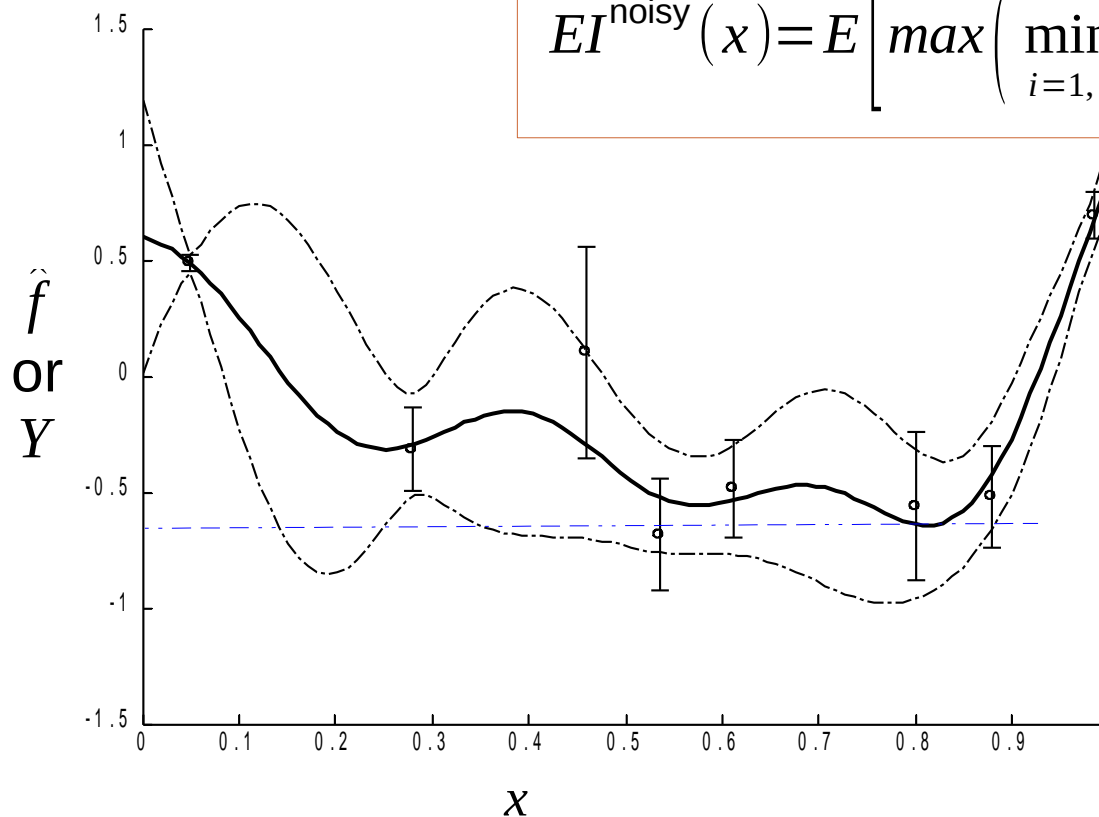

known analytically  
replace  $f_{min}$  by  
 $\min_{i=1,t} m_K(x^i)$   
in *EI* formula

# Kriging-based robust optimization, no control on U

## Expected Quantile Improvement

V. Picheny, D. Ginsbourger, Y. Richet, *Optimization of noisy computer experiments with tunable precision*, Technometrics, 2011.

Solution 2 : Add nugget effect and use the expected quantile improvement.

$$EQI(x) = E \left[ \max \left( q_{min} - Q^{t+1}(x), 0 \right) \right]$$

$$q_{min} = \min_{i=1,t} m_K(x^i) + \alpha s_K(x^i)$$

$$Q^{t+1}(x) = M_K^{t+1}(x) + \alpha s_K^{t+1}(x)$$

$M_K^{t+1}(x)$  is a linear function of  $Y(x)$

$\Rightarrow EQI(x)$  is known analytically

A conservative criterion (noise and spatial uncertainties are seen as risk rather than opportunities).

Better for assigning resources to reduce noise on a given DoE  $X^t$  obtained by Solution 1.

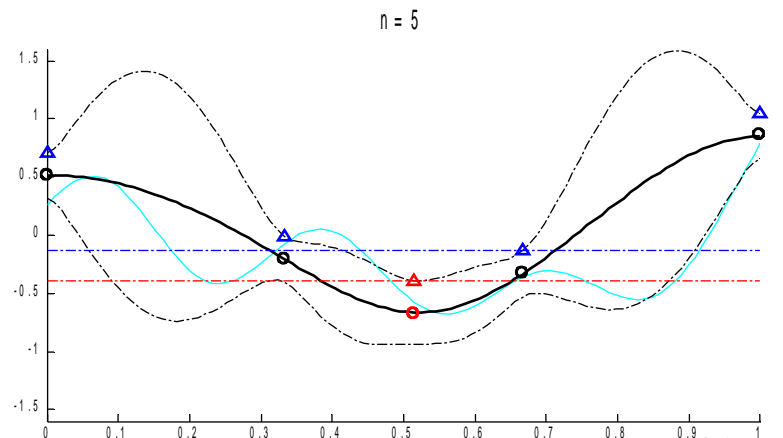
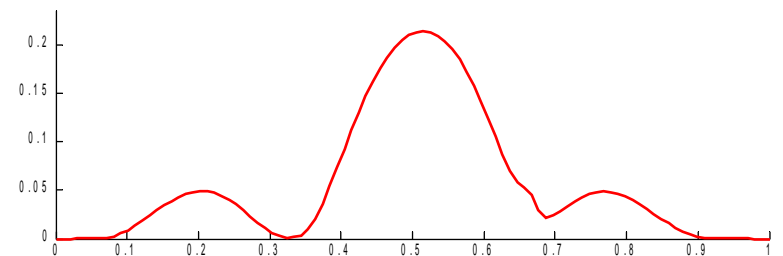
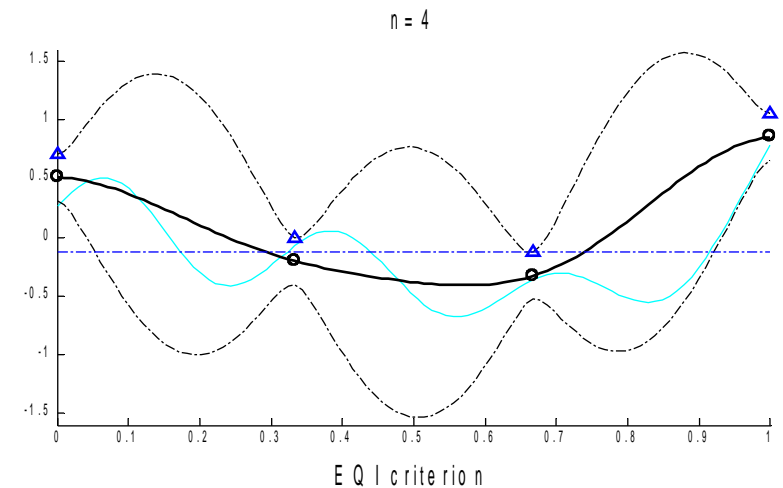

# Outline of the talk

---

1. Motivations for robust optimization
2. Formulations of optimization problems with uncertainties
3. Kriging-based approaches to robust optimization (costly functions)
  - Kriging noisy observations
  - Optimization and kriging
  - Robust optimization, no control on  $U$
  -  Robust optimization, control on  $U$
4. Evolutionary approaches (non costly functions)

# Kriging based optimization with uncertainties, $U$ controlled $(x,u)$ surrogate based approach

---

Assumptions :  $x$  and  $U$  controlled

$Y$  : surrogate model

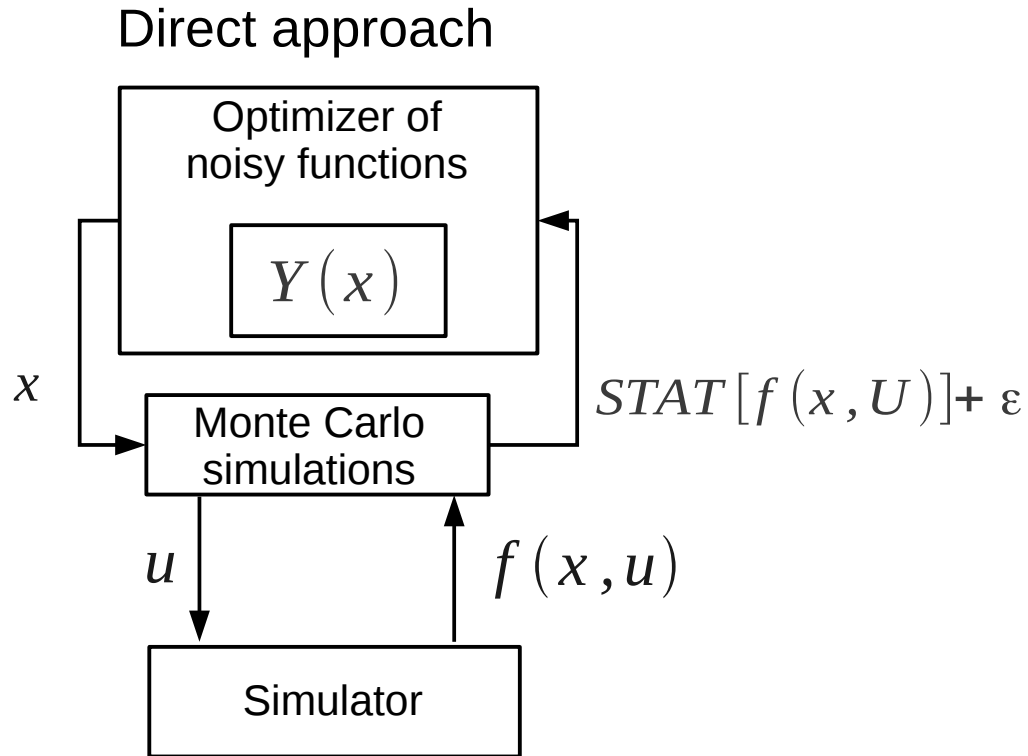

Multiplicative cost of two loops involving  $f$

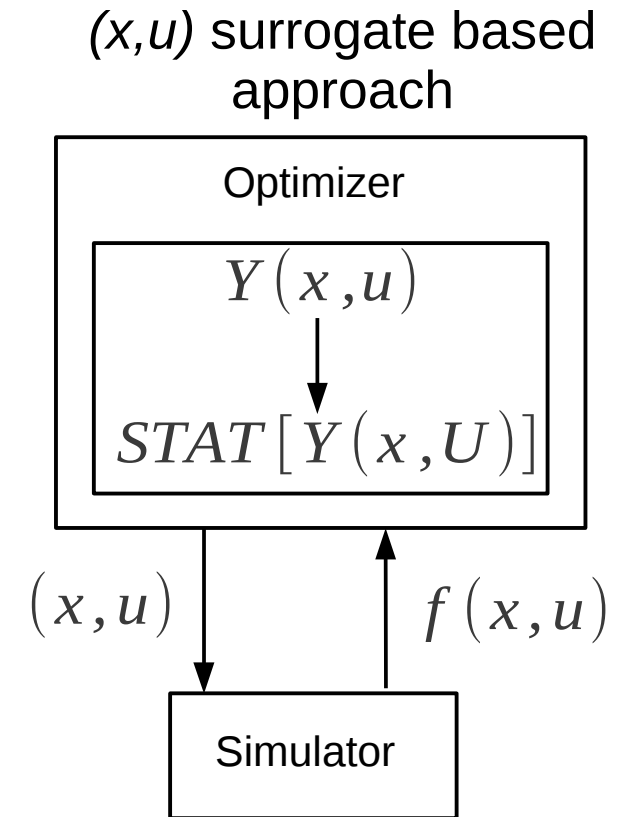

Only one loop of  $f$

# Kriging based optimization with uncertainties, U controlled

## A general Monte Carlo - kriging algorithm

Hereafter is an example of a typical surrogate-based (here kriging) algorithm for optimizing any statistical measure of  $f(x,u)$  (here the average).

Create initial DOE  $(X^t, U^t)$  and evaluate  $f$  there ;  
While stopping criterion is not met:

MC – kriging algorithm

- Create kriging approximation  $Y^t$  in the joint  $(x,u)$  space from  $f(X^t, U^t)$
- Estimate the value of the statistical objective function from Monte Carlo simulations on the kriging average  $m_Y^t$ .

$$\text{Expl : } \hat{f}(x^i) = \frac{1}{S} \sum_{k=1}^S m_K^t(x^i, u^k) \quad , \quad \text{where } u^k \text{ i.i.d. from pdf of } U$$

- Create kriging approximation  $Z^t$  in  $x$  space from  $(x^i, \hat{f}(x^i))_{i=1,t}$
- Maximize  $EI_Z^{\text{noisy}}(x)$  to obtain the next simulation point  $\rightarrow x^{t+1}$   
 $u^{t+1}$  sampled from pdf of  $U$
- Calculate simulator response at the next point,  $f(x^{t+1}, u^{t+1})$ .  
Update DOE and  $t$

only call to f !



# Kriging based optimization with uncertainties, U controlled Simultaneous optimization and sampling

---

**Objective :**  $\min_x \mathbb{E}_U [f(x, U)]$

Principle : work in the joint (x,u) space.

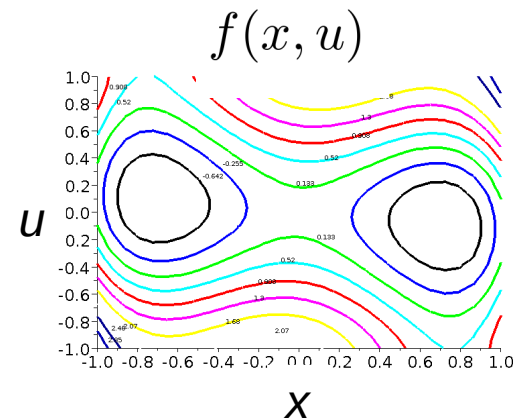

Cf. J. Janusevskis and R. Le Riche, *Simultaneous kriging-based estimation and optimization of mean response*, Journal of Global Optimization, Springer, 2012

# Kriging based optimization with uncertainties, U controlled Integrated kriging (1)

$$\min_x \mathbb{E}_U [f(x, U)] : \text{objective}$$

$$Y_{(x,u)}^t(\omega) : \text{kriging approximation to deterministic } f(x, u)$$

$$Z_{(x)}^t(\omega) = \mathbb{E}_U [Y_{(x,U)}^t(\omega)] : \text{integrated process approximation to } \mathbb{E}_U [f(x, U)]$$

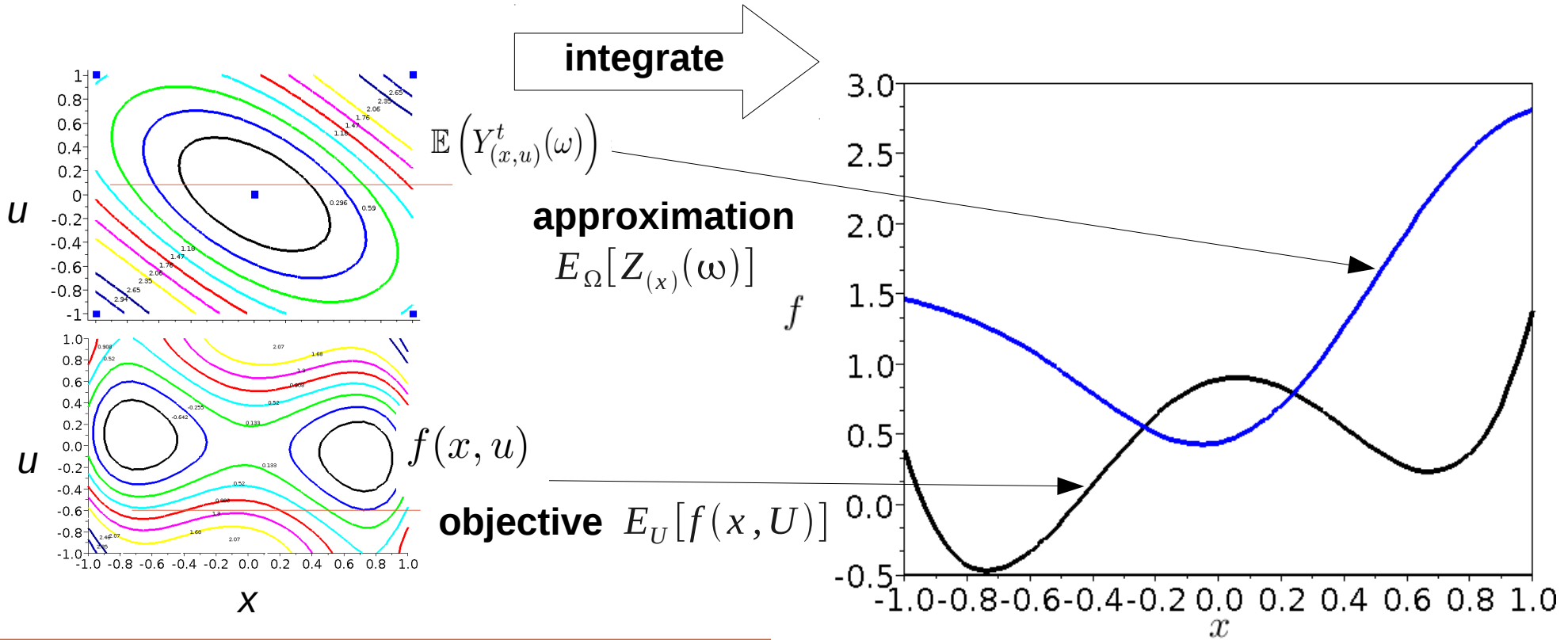

# Kriging based optimization with uncertainties, U controlled Integrated kriging (2)

---

The integrated process over  $U$  is defined as

$$Z_{(x)}(\omega) = \mathbb{E}_U [Y_{(x,U)}^t(\omega)] = \int_{\mathbb{R}^m} Y_{(x,u)}^t(\omega) d\mu(u)$$

$d\mu(u)$ -probability measure on  $U$

Because it is a linear transformation of a Gaussian process, it is Gaussian, and fully described by its mean and covariance

$$m_Z(x) = \int_{\mathbb{R}^m} m_Y(x, u) d\mu(u)$$

$$\text{cov}_Z(x; x') = \int_{\mathbb{R}^m} \int_{\mathbb{R}^m} \text{cov}_Y(x, u; x' u') d\mu(u) d\mu(u')$$

Analytical expressions of  $m_Z$  and  $\text{cov}_Z$  for Gaussian  $U$ 's are given in

J. Janusevskis and R. Le Riche, *Simultaneous kriging-based estimation and optimization of mean response*, Journal of Global Optimization, Springer, 2012

# Kriging based optimization with uncertainties, U controlled EI on the integrated process (1)

---

$Z$  is a process approximating the objective function  $\mathbb{E}_U[f(x, U)]$

Optimize with an Expected Improvement criterion,

$$x^{next} = \arg \max_x EI_Z(x)$$

Optimize with an Expected Improvement criterion,

$I_Z(x) = \max(z_{min} - Z(x), 0)$  , but  $z_{min}$  not observed (in integrated space).  
 $\Rightarrow$  Define  $z_{min} = \min_{x^1, \dots, x^t} E(Z(x))$

# Kriging based optimization with uncertainties, U controlled EI on the integrated process (2)

---

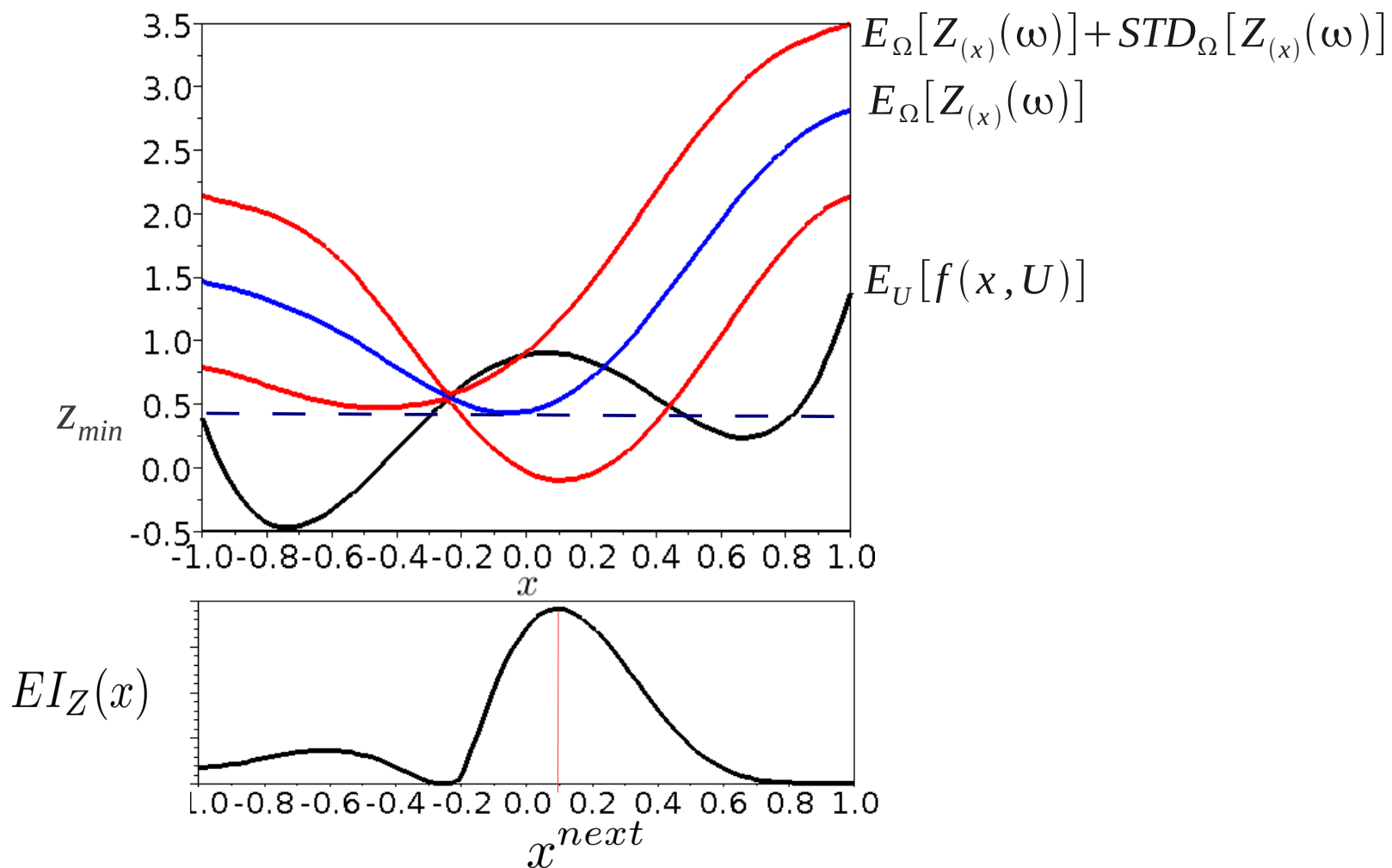

# Kriging based optimization with uncertainties, U controlled EI on the integrated process (3)

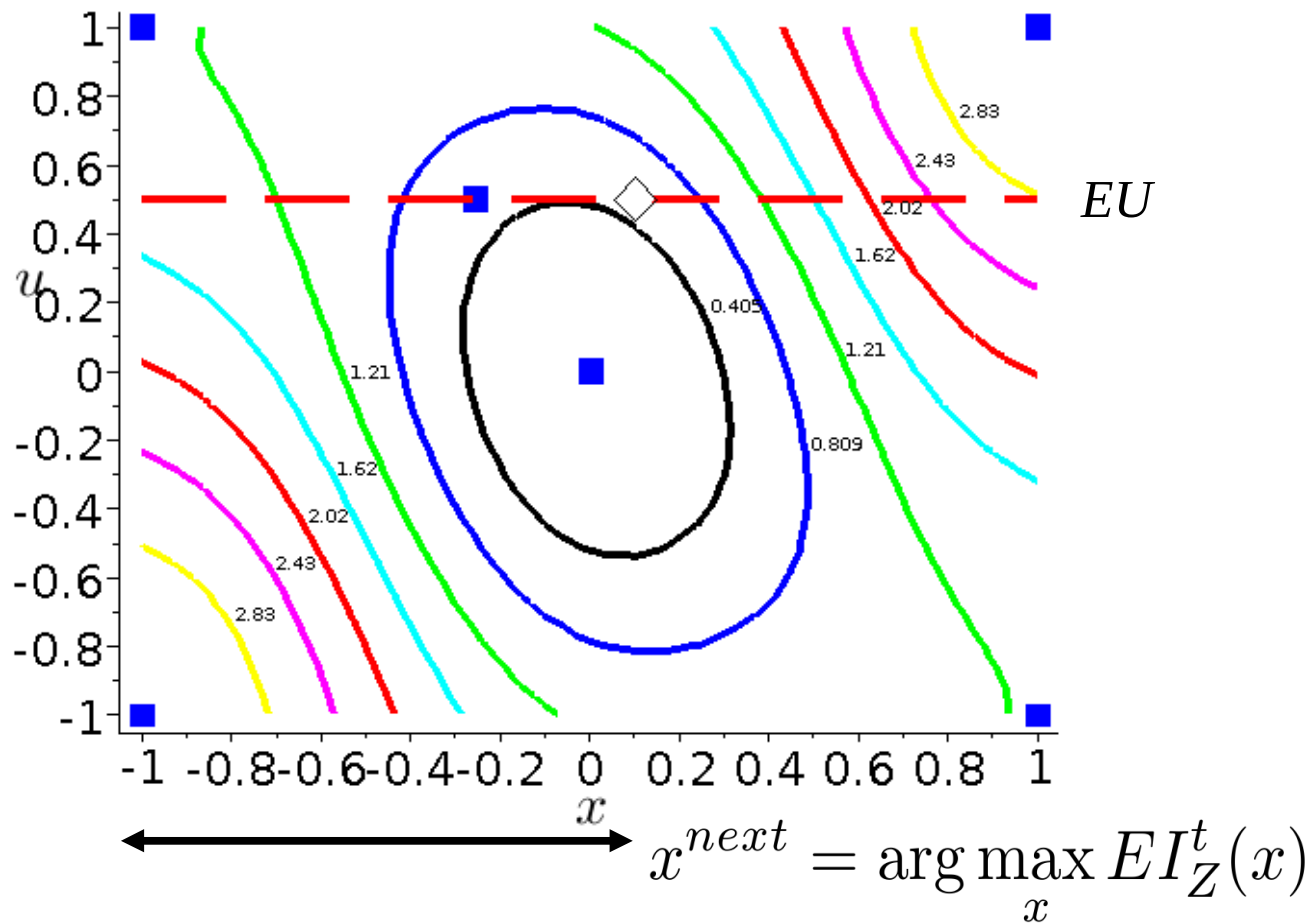

$x$  ok. What about  $u$  ? (which we need to call the simulator)

# Kriging based optimization with uncertainties, U controlled Simultaneous optimization and sampling : method

---

$x^{next}$  gives a region of interest from an optimization of the expected  $f$  point of view.

One simulation will be run to improve our knowledge of this region of interest → one choice of  $(x,u)$ .

Choose  $(x^{t+1}, u^{t+1})$  that provides the most information, i.e., which minimizes the variance of the integrated process at  $x^{next}$

$$(x^{t+1}, u^{t+1}) = \arg \min_{x,u} \text{VAR} Z_{(x^{next})}^{t+1}(\omega)$$

# Kriging based optimization with uncertainties, U controlled Simultaneous optimization and sampling : expl.

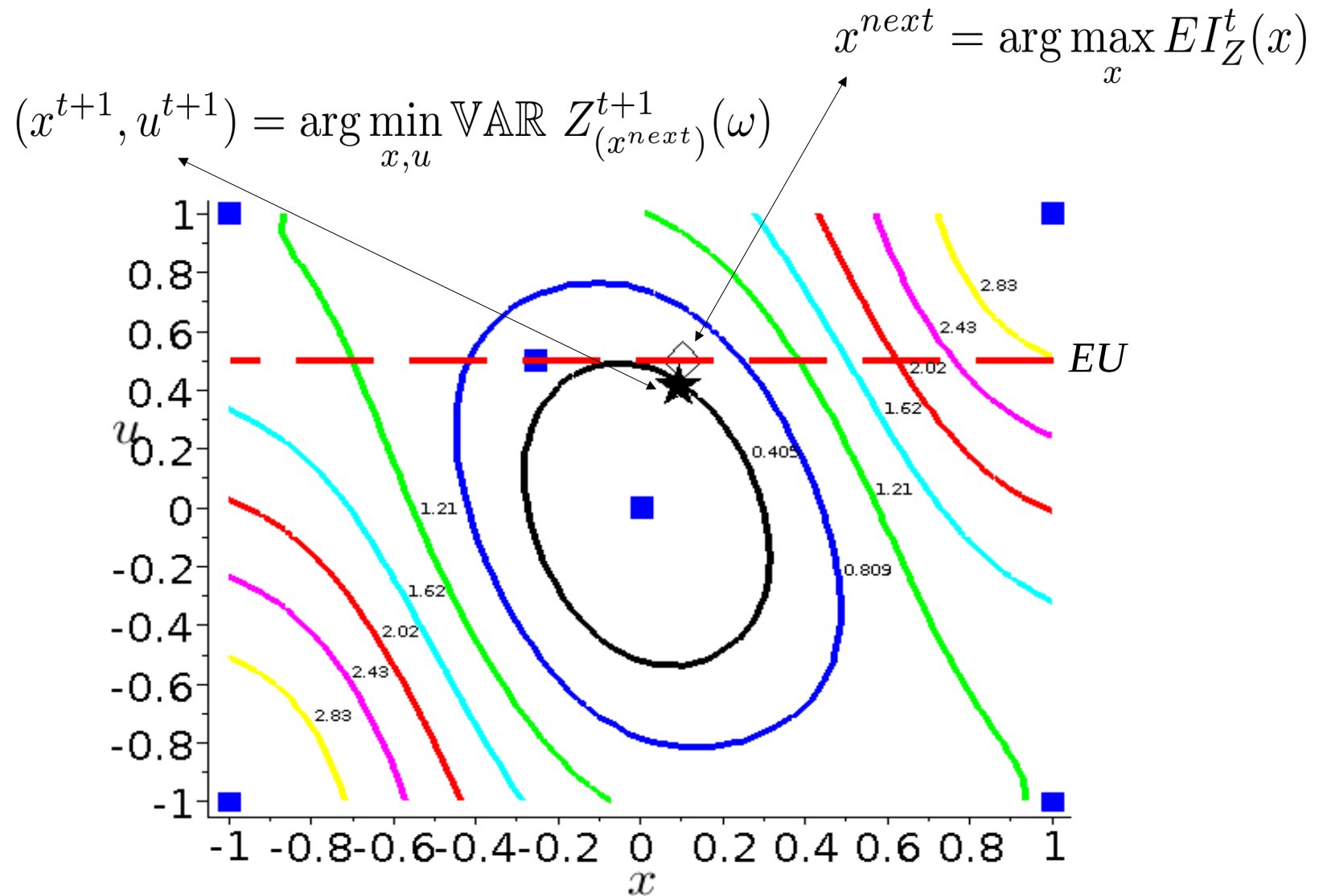



# Kriging based optimization with uncertainties, U controlled Simultaneous optimization and sampling : algo

---

Create initial DOE in  $(x,u)$  space;

While stopping criterion is not met:

- Create kriging approximation  $Y$  in the joint space  $(x,u)$
- Using covariance information of  $Y$  to obtain approximation  $Z$  of the objective in the deterministic space  $(x)$
- Use EI of  $Z$  to choose  $(x^{next})$
- Minimize  $VAR(Z(x^{next}))$  to obtain the next point  $(x^{t+1}, u^{t+1})$  for simulation
- Calculate simulator response at the next point  $f(x^{t+1}, u^{t+1})$

( 4 sub-optimizations, solved with CMA-ES )

---

# Kriging based optimization with uncertainties, U controlled 2D Expl, simultaneous optimization and sampling

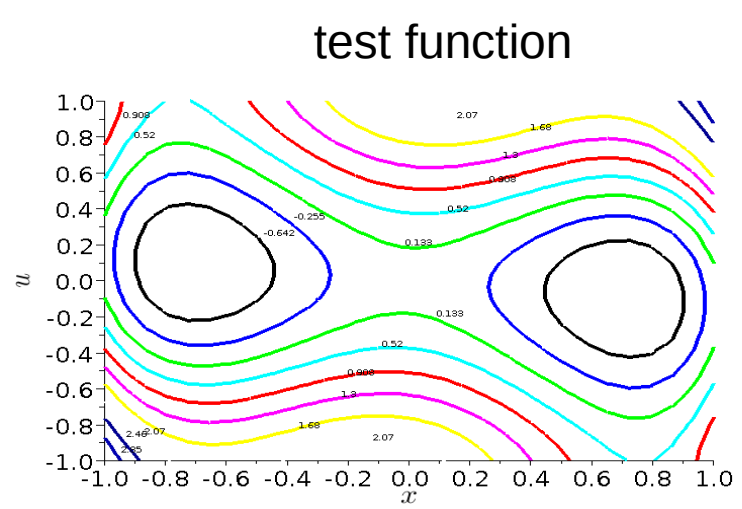
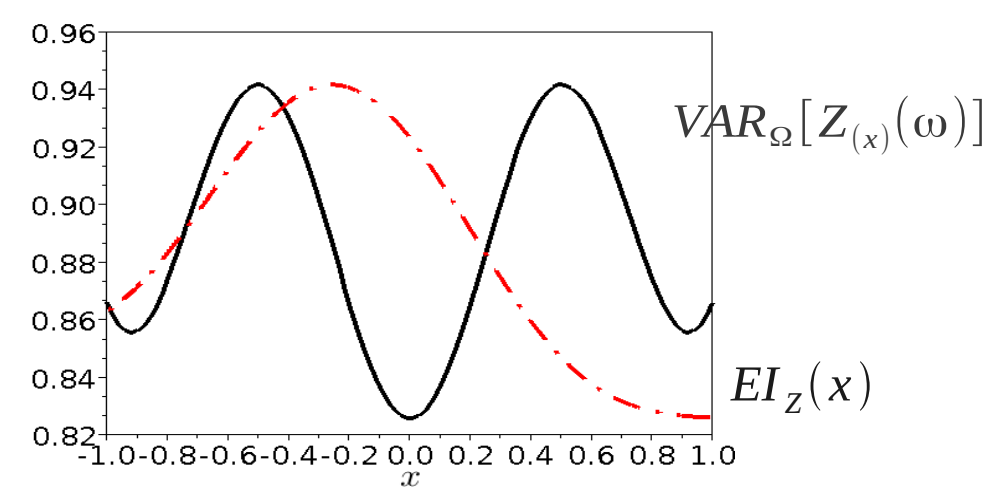
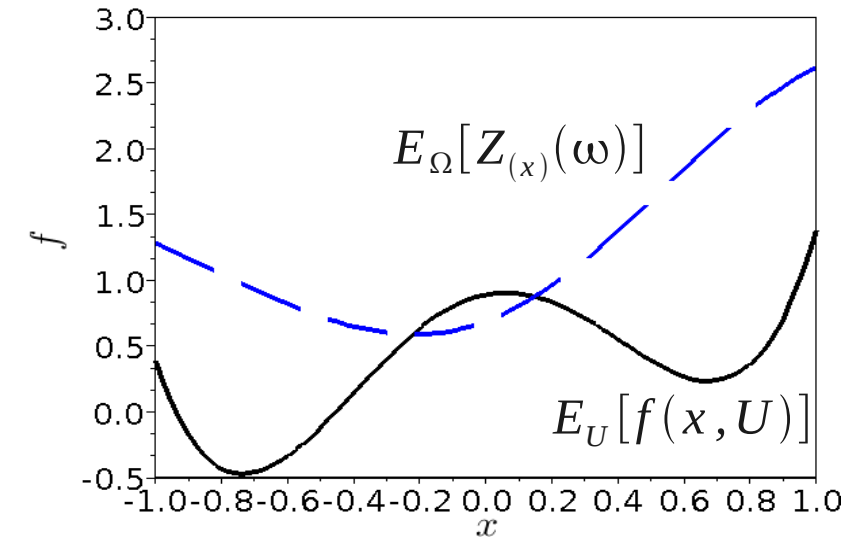
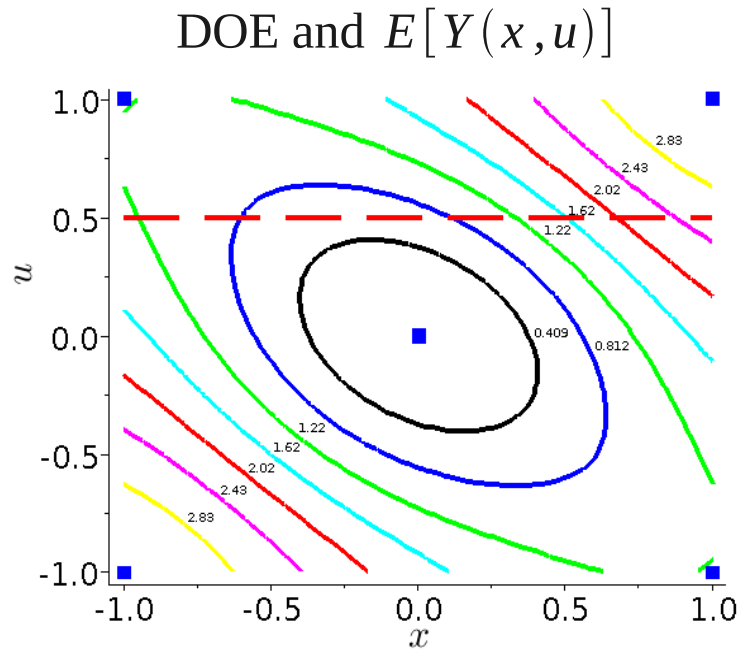

# Kriging based optimization with uncertainties, U controlled 1st iteration

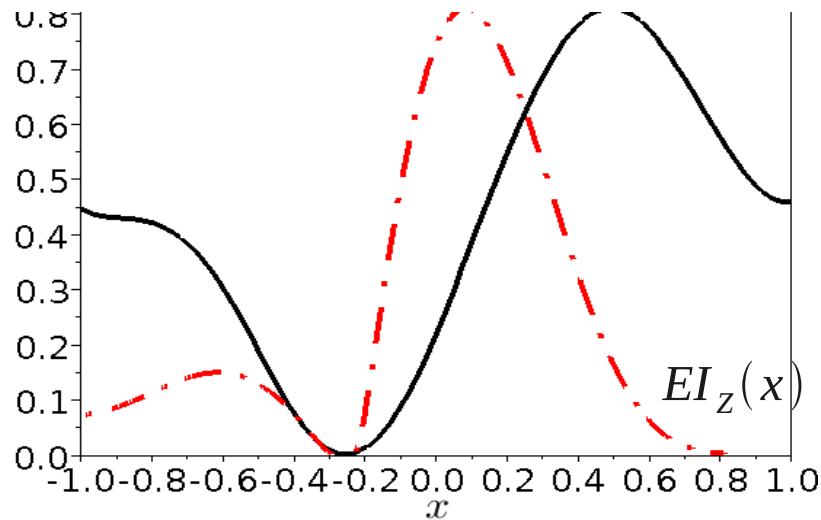
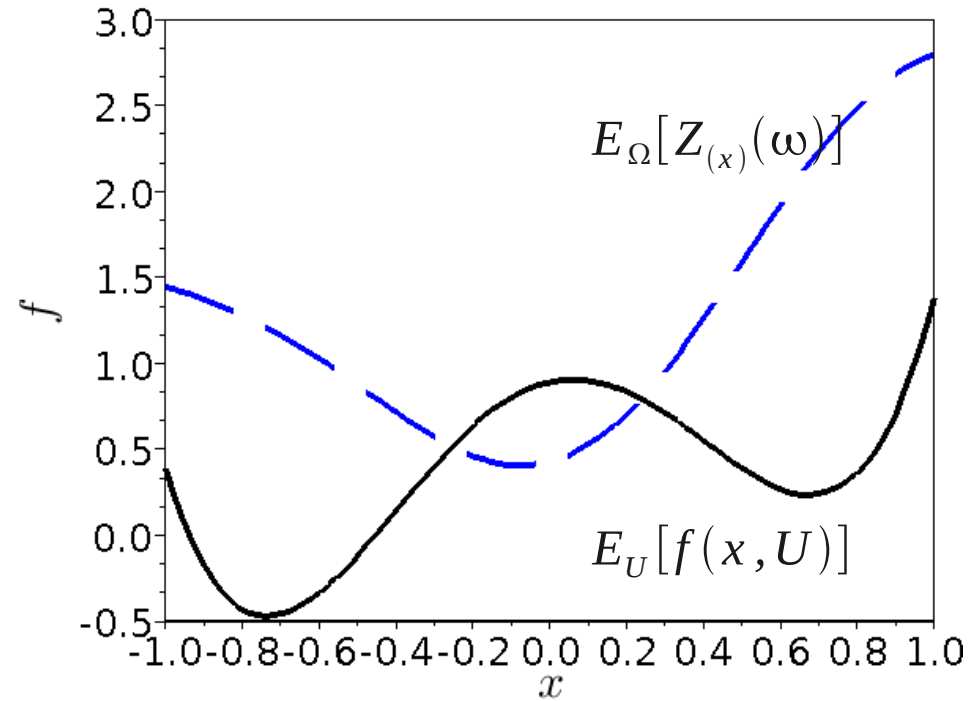
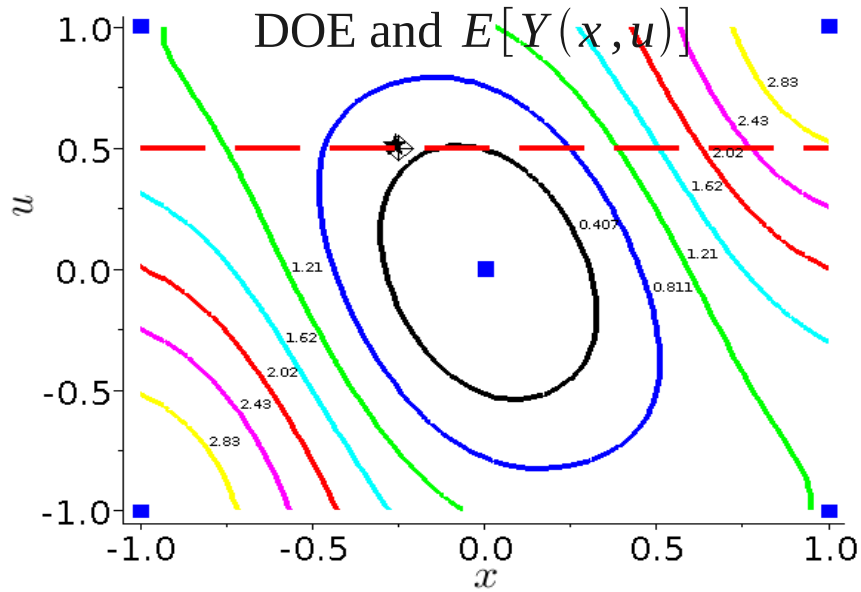

$$VAR_\Omega[Z_{(x)}(\omega)]$$

- $\diamond$  —  $(x^{next}, \mu)$
- $\star$  —  $(x^{t+1}, u^{t+1})$

# Kriging based optimization with uncertainties, U controlled 2nd iteration

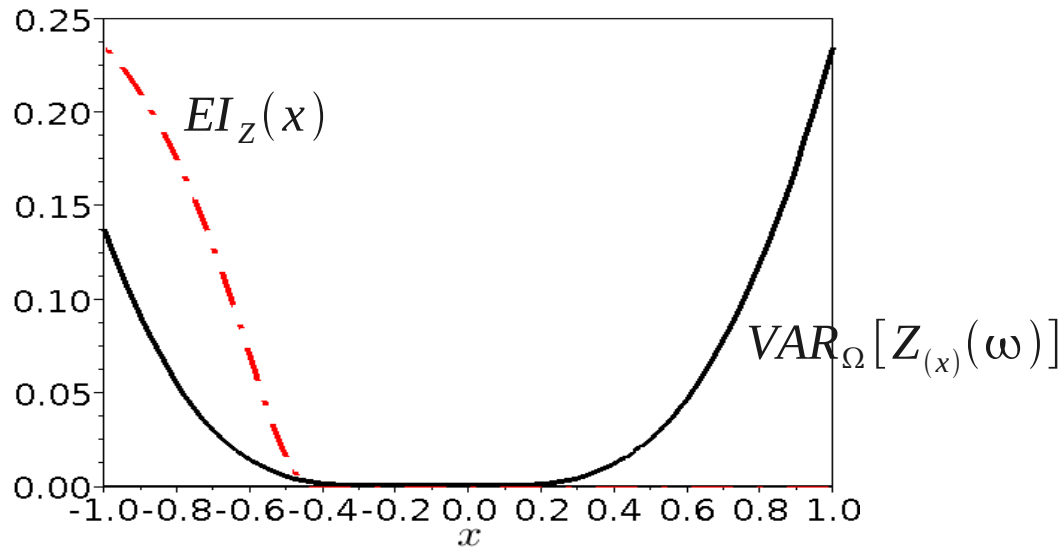
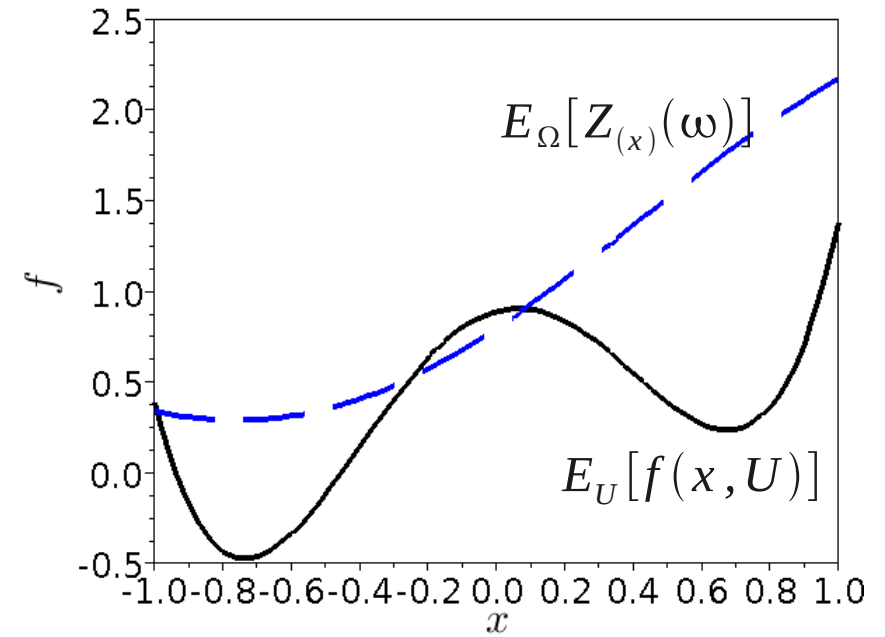
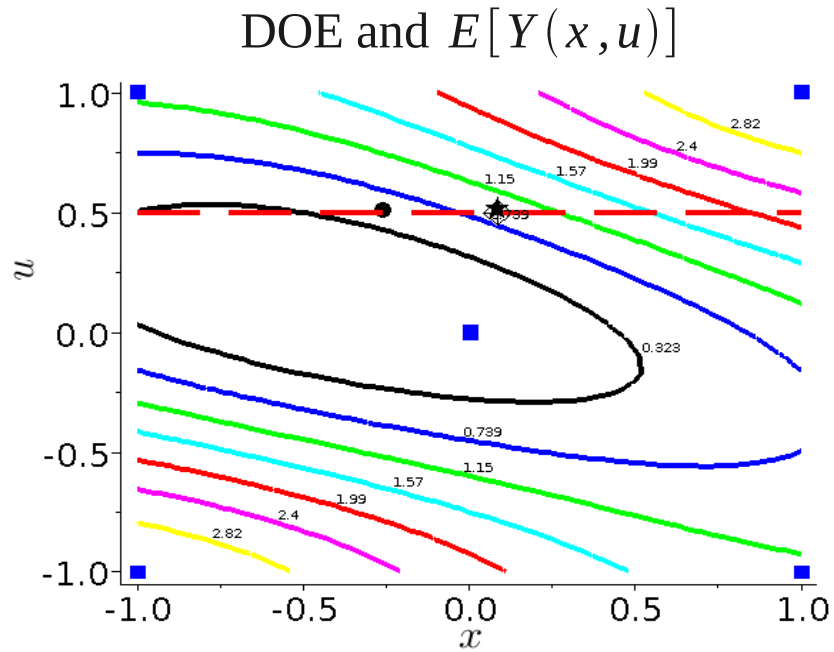

- $\blacklozenge$  —  $(x^{next}, \mu)$
- $\star$  —  $(x^{t+1}, u^{t+1})$

# Kriging based optimization with uncertainties, U controlled 3rd iteration

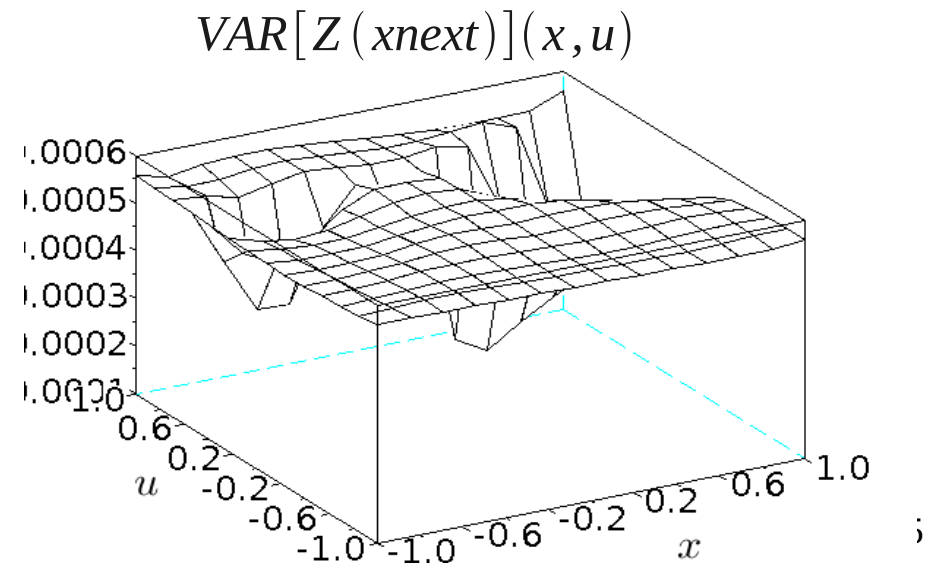
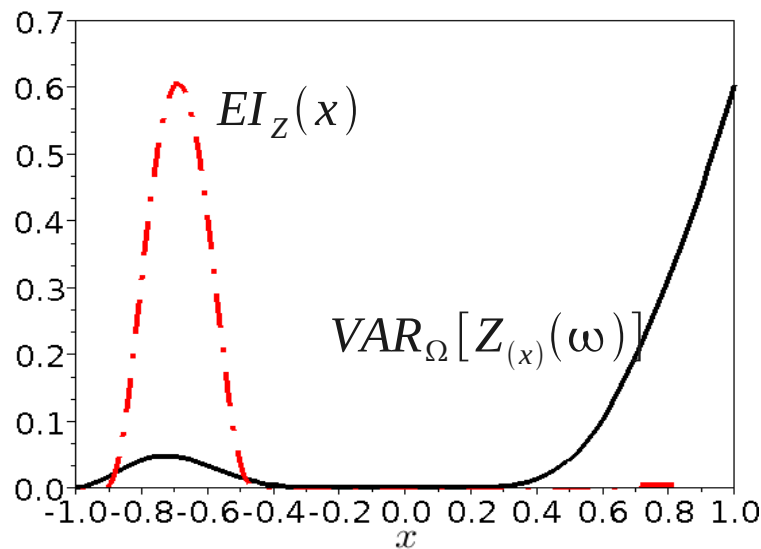
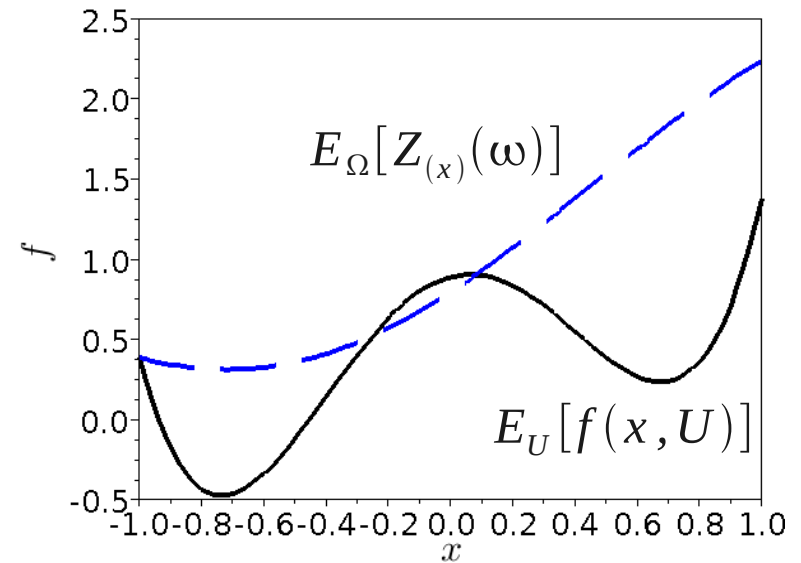
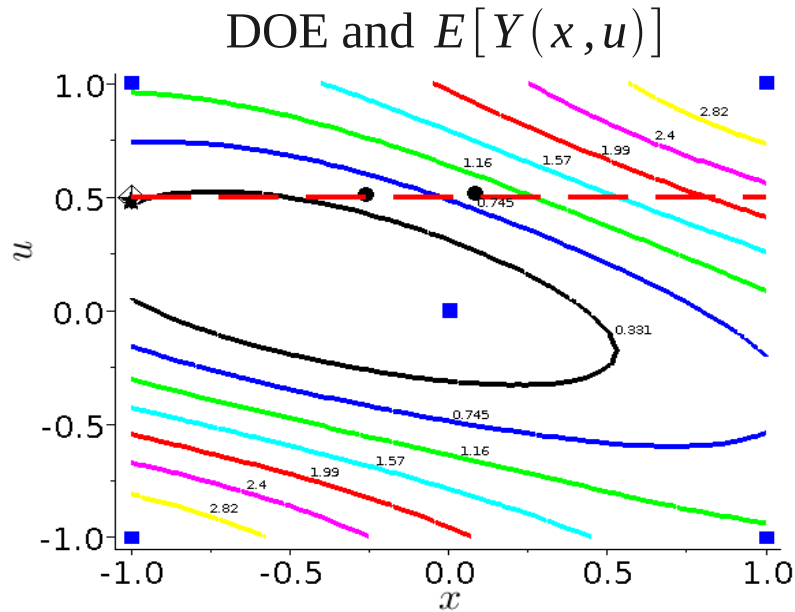

# Kriging based optimization with uncertainties, U controlled 5th iteration

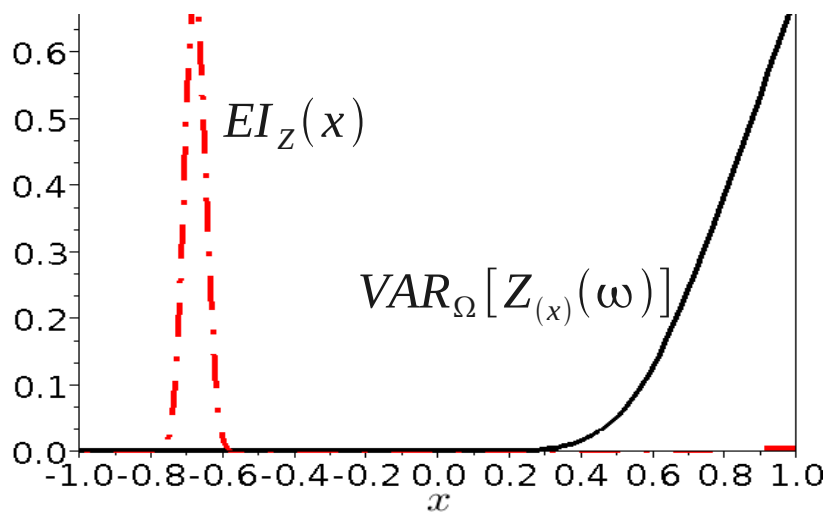
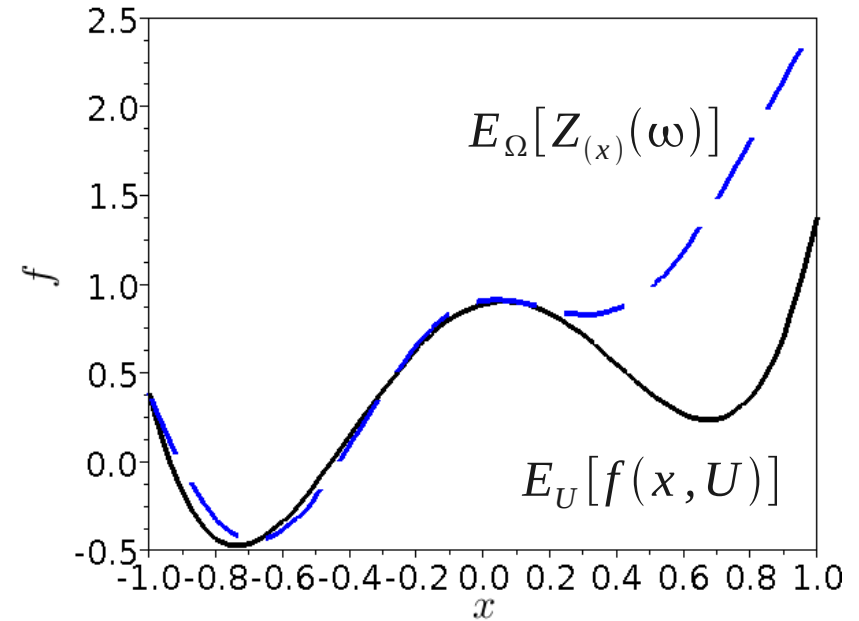
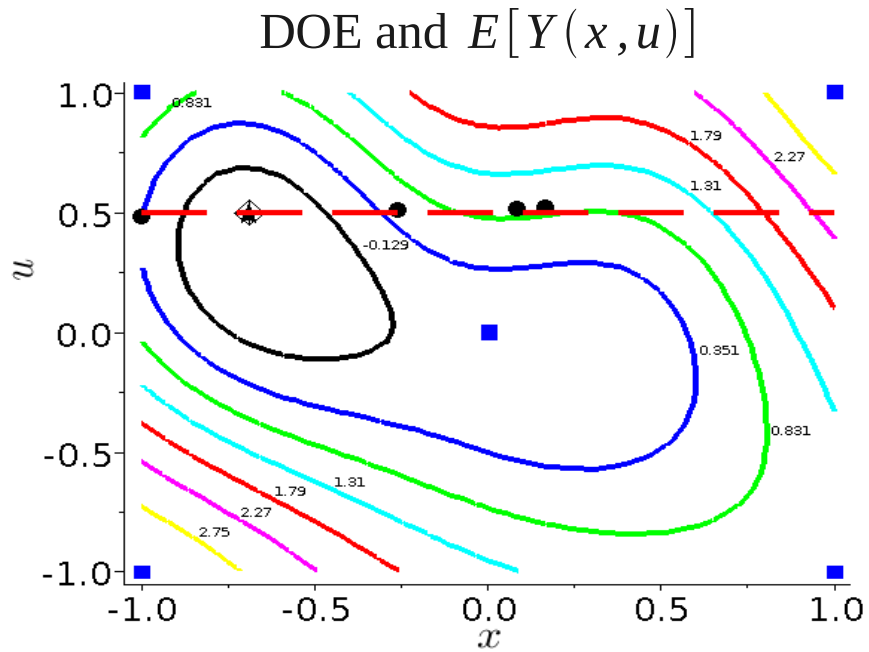

- $\diamond$  —  $(x^{next}, \mu)$
- $\star$  —  $(x^{t+1}, u^{t+1})$

# Kriging based optimization with uncertainties, U controlled

## 17th iteration

DOE and  $E[Y(x,u)]$

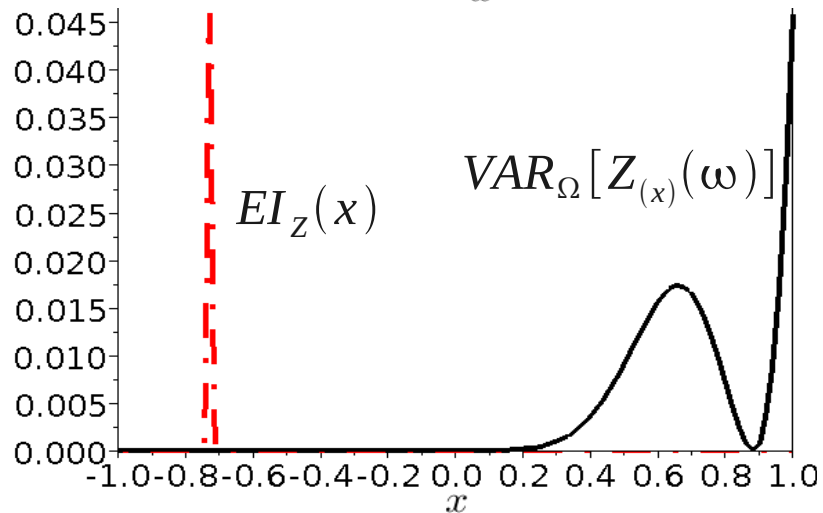
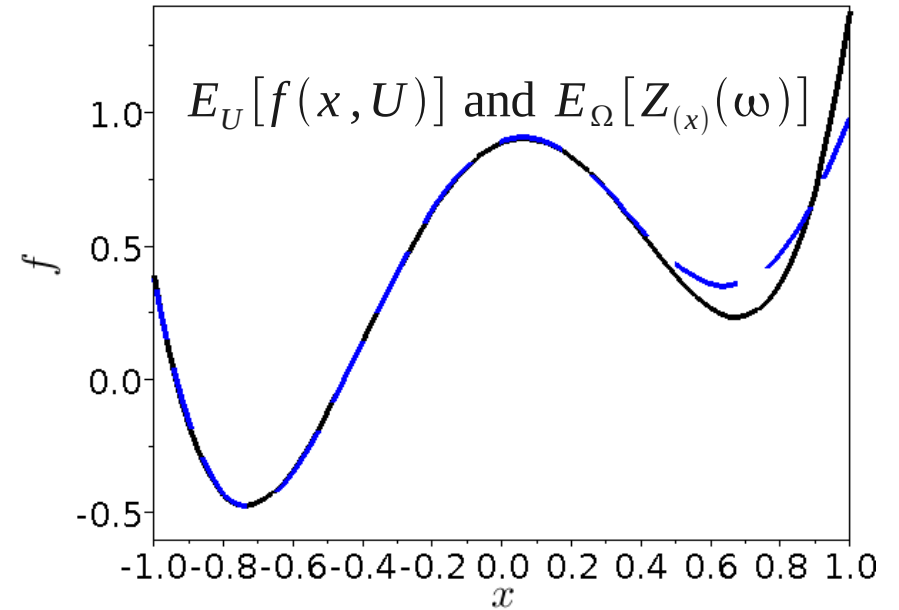
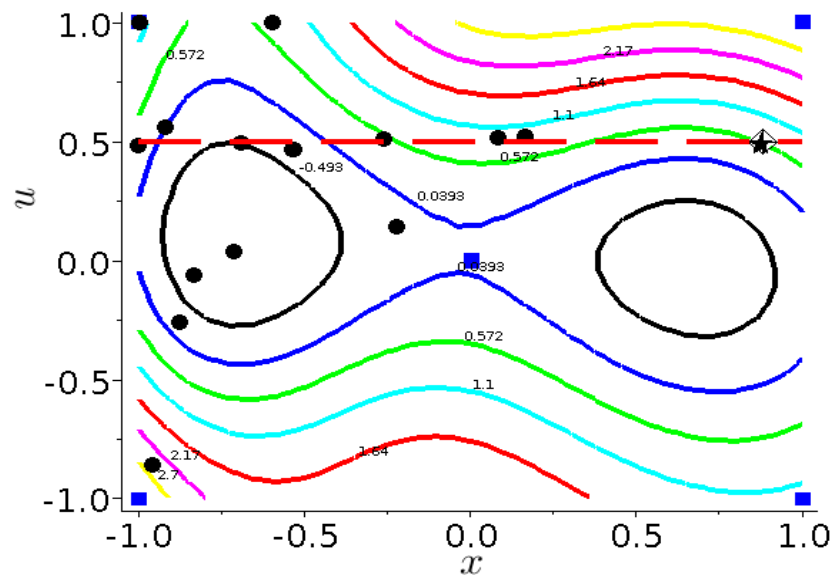

# Kriging based optimization with uncertainties, U controlled

## 50th iteration

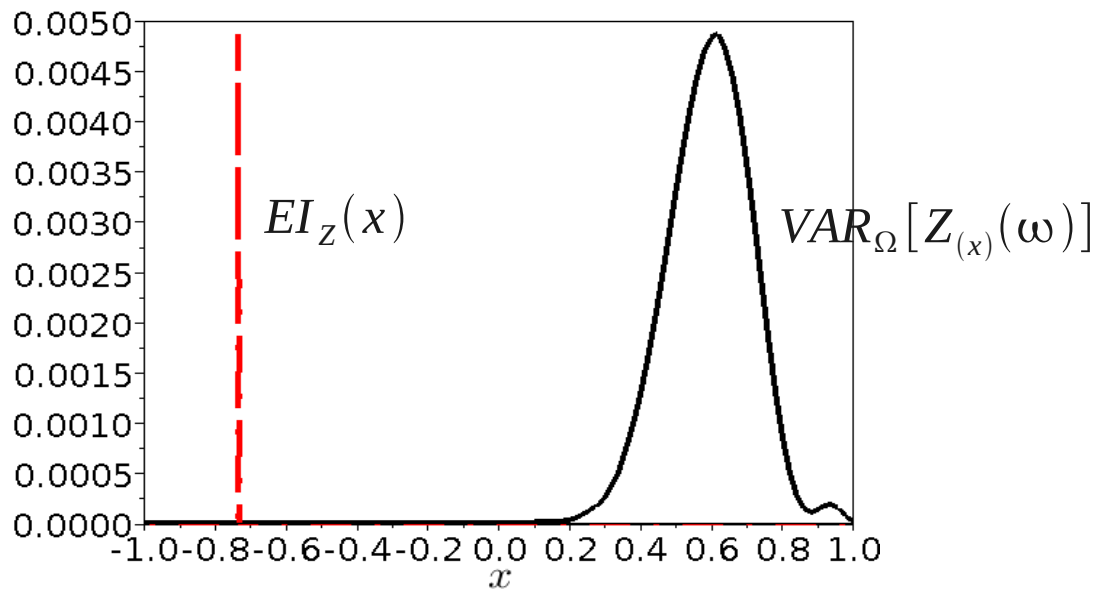
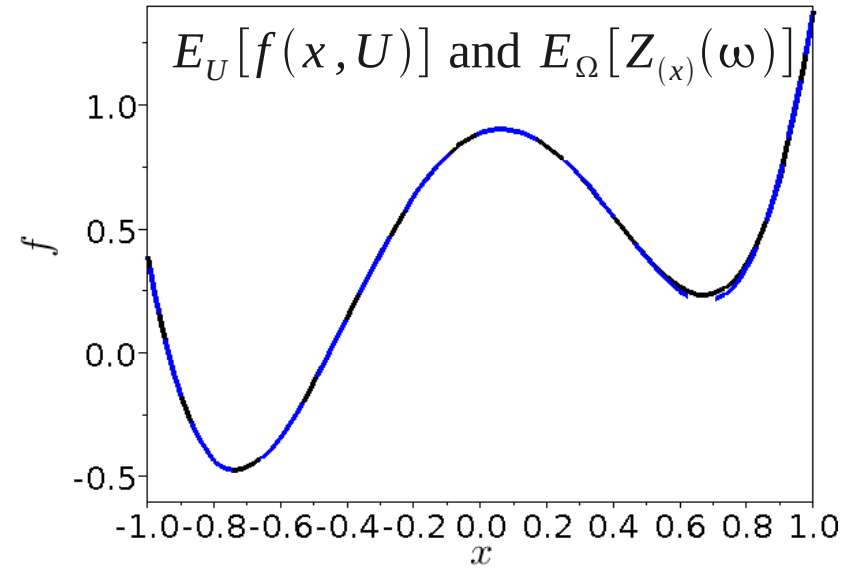
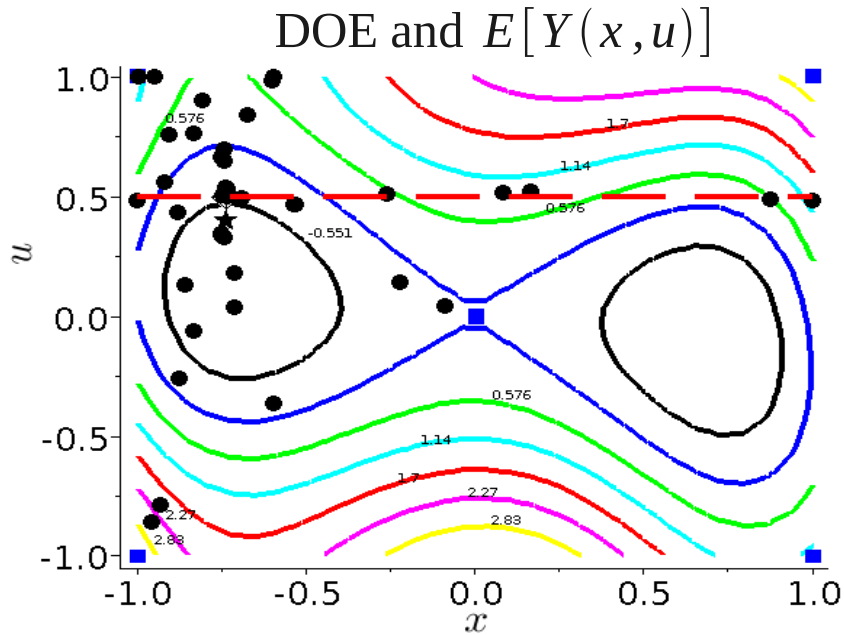



# Kriging based optimization with uncertainties, U controlled

## Comparison tests

---

Compare « simultaneous opt and sampling » method to

1. A direct MC based approach :  
EGO based on MC simulations in  $f$  with fixed number of runs,  $s$ .  
Kriging with homogenous nugget to filter noise.
2. An MC-surrogate based approach :  
the MC-kriging algorithm.

# Kriging based optimization with uncertainties, U controlled

## Test functions

Test cases based on Michalewicz function

$$f(x) = -\sum_{i=1}^n \sin(x_i) [\sin(ix_i^2/\pi)]^2$$

$$f(x, u) = f(x) + f(u)$$

2D:  $n_x=1$   $n_u=1$   $\mu=1.5$   $\sigma=0.2$

4D:  $n_x=2$   $n_u=2$   $\mu=[1.5, 2.1]$   $\sigma=[0.2, 0.2]$

6D:  $n_x=3$   $n_u=3$   $\mu=[1.5, 2.1, 2]$   $\sigma=[0.2, 0.2, 0.3]$

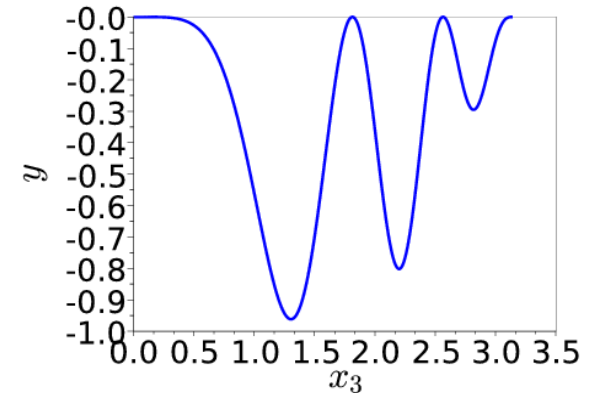
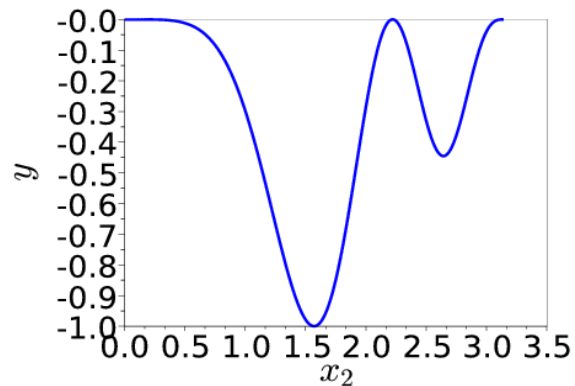
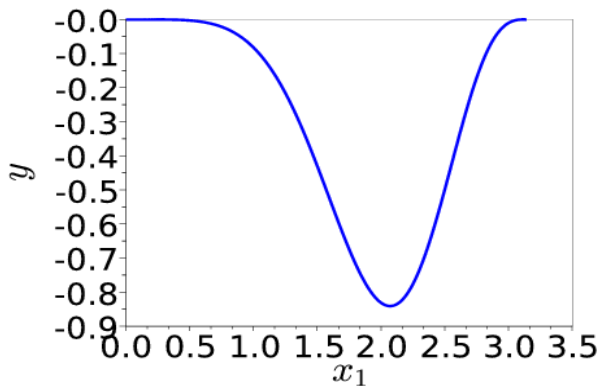
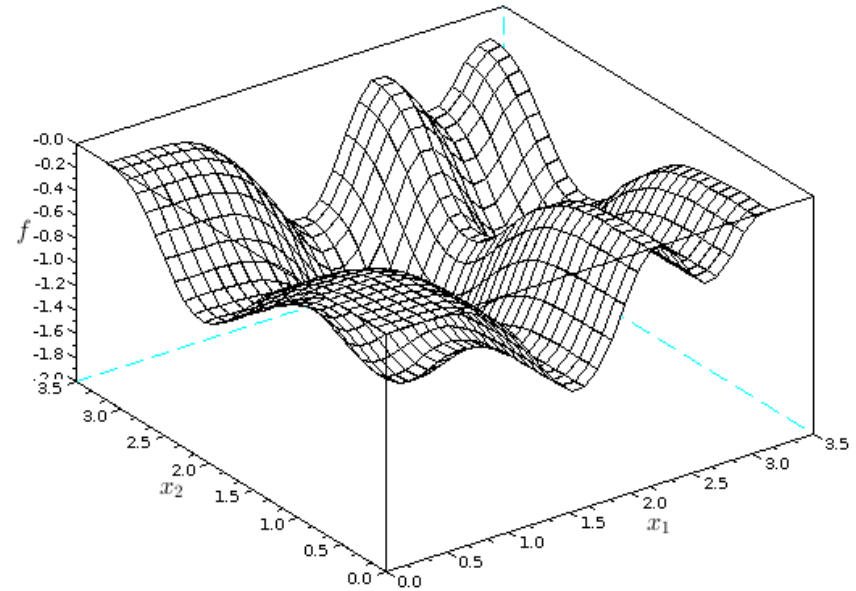

# Kriging based optimization with uncertainties, U controlled

## Test results

6D Michalewicz test case,  $n_{x=3} = 3$ ,  $n_U = 3$ .

Initial DOE: RLHS,  $m = (n_x + n_U) * 5 = (3 + 3) * 5 = 30$ ;

10 runs for every method.

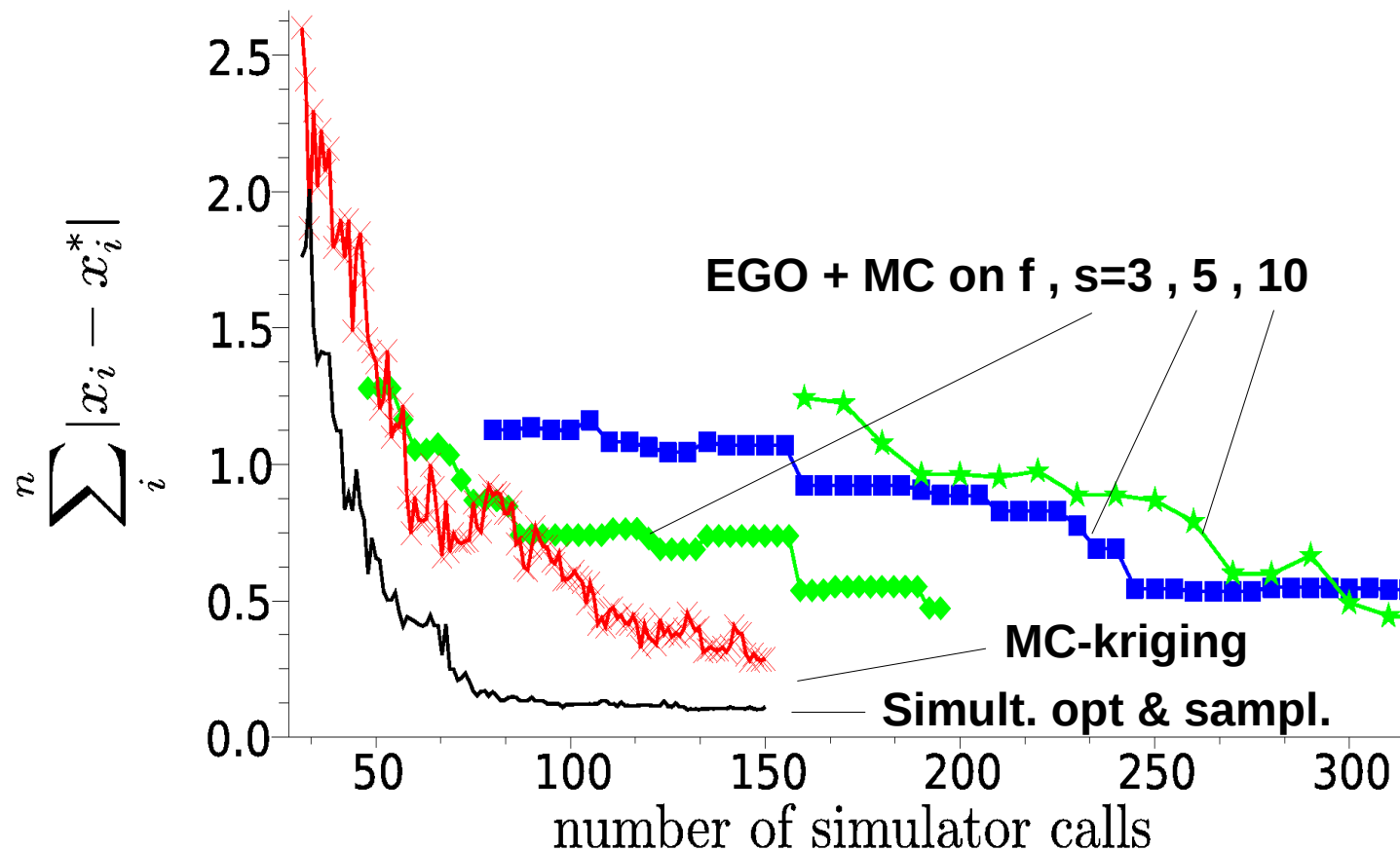

# Partial conclusion

---

- $\min_x f(x, U)$

We have discussed spatial statistics to filter the noise → kriging based approaches.

- Limitation : number of dimensions ,  $\dim(x) + \dim(U) < 20$

Beyond this, if the function  $f$  is not too costly, use stochastic evolutionary optimizers, which can be relatively robust to noise if properly tuned.

- Useful for optimizing statistical estimators which are noisy.
- No control over the  $U$ 's
- No spatial statistics (i.e. in  $S$  or  $S \times U$  spaces), pointwise approaches only.

# Outline of the talk

---

1. Motivations for robust optimization
2. Formulations of optimization problems with uncertainties
3. Kriging-based approaches (costly functions)
  - No control on  $U$
  - With control on  $U$
4. Evolutionary approaches (non costly functions)
  - The general CMA-ES
  - Improvements for noisy functions :
    - Mirrored sampling and sequential selection
    - ~~Adding confidence to an ES~~

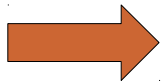

# Noisy optimization

## Evolutionary algorithms

---

Taking search decisions in probability is a way to handle the noise corrupting observed  $f$  values

→ use a stochastic optimizer, an evolution strategy (ES).

« elitism »

A simple (1 $\oplus$ 1)-ES

Initializations :  $x, f(x), m, C, t_{max}$ .

While  $t < t_{max}$  do,

Sample  $N(m, C) \rightarrow x'$

Calculate  $f(x'), t = t + 1$

▶ If  $f(x') < f(x)$ ,  $x = x', f(x) = f(x')$  Endif

Update  $m$  (e.g.,  $m = x$ ) and  $C$

End while

%(Scilab code)

$x = m + \text{grand}(1, 'mn', 0, C)$

2-D Normal Distribution

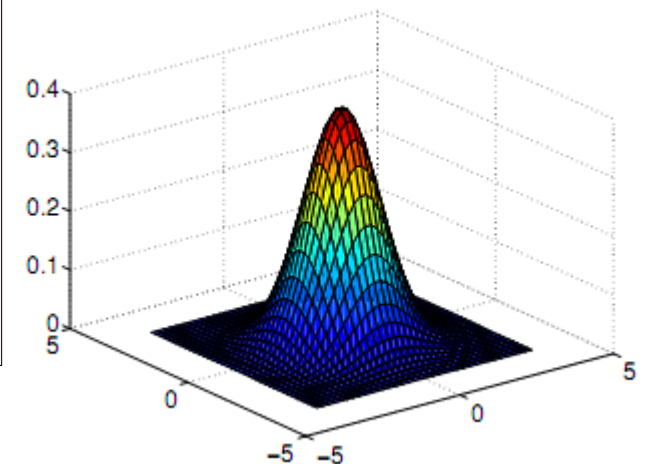

# Noisy optimization Adapting the step size ( $C^2$ ) is important

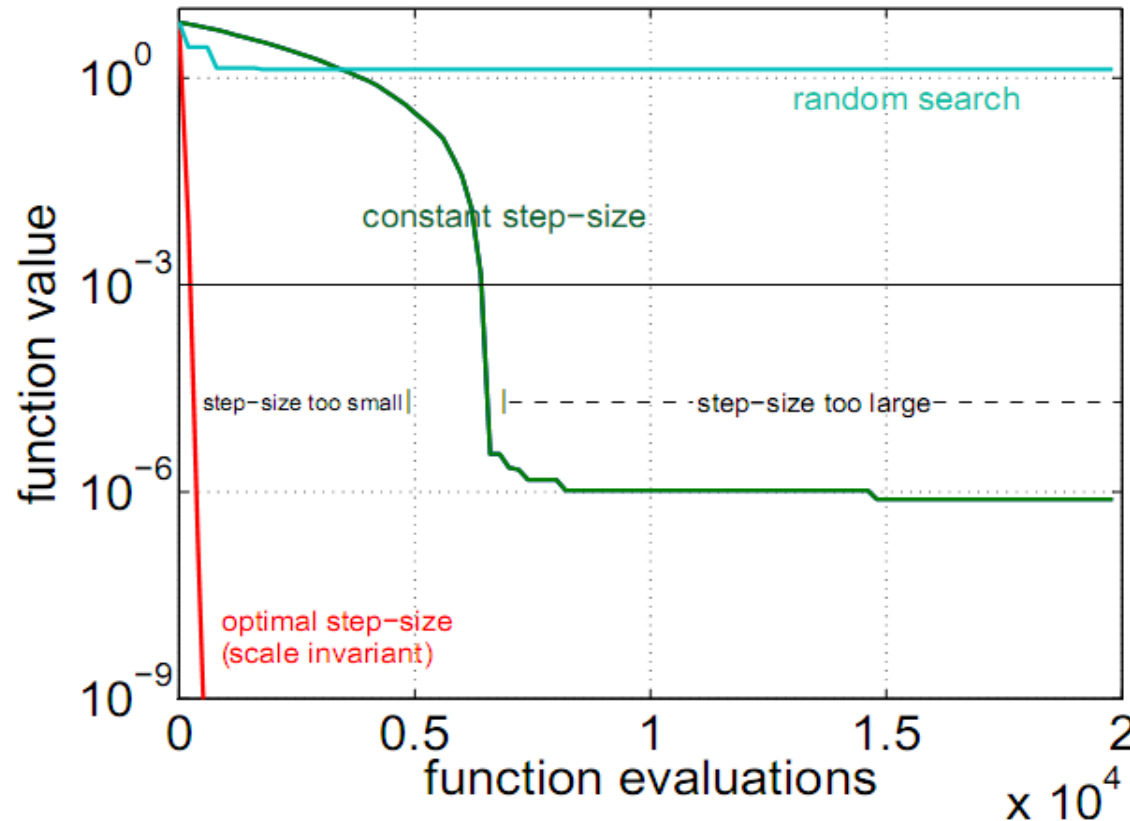

$$f(x) = \sum_{i=1}^n x_i^2$$

in  $[-0.2, 0.8]^n$   
for  $n = 10$

(A. Auger et N.  
Hansen, 2008)

Above isotropic ES(1+1) :  $C = \sigma^2 I$  ,  $\sigma$  is the step size.

With an optimal step size ( $\approx \|x\|/d$ ) on the sphere function, log linear speed that degrades only in  $O(d)$ .

# The population based CMA-ES

---

(N. Hansen et al., since 1996, now with A. Auger)

CMA-ES = *Covariance Matrix Adaptation Evolution Strategy* = optimization through sampling and updating of a multi-normal distribution.

A fully populated covariance matrix is build : pairwise variables interactions learned. Can adapt the step in any direction.

The state-of-the-art evolutionary / genetic optimizer for continuous variables.



## Noisy optimization flow-chart of CMA-ES

---

CMA-ES is an evolution strategy  $ES-(\mu, \lambda)$  :

Initializations :  $m, C, t_{max}, \mu, \lambda$

While  $t < t_{max}$  do,

Sample  $N(m, C) \rightarrow x^1, \dots, x^\lambda$

Calculate  $f(x^1), \dots, f(x^\lambda)$ ,  $t = t + \lambda$

Rank :  $f(x^{1:\lambda}), \dots, f(x^{\lambda:\lambda})$

Update  $m$  and  $C$  with the  $\mu$  bests,  
 $x^{1:\lambda}, \dots, x^{\mu:\lambda}$

End while

$m$  et  $C$  are updated with

- the best **steps** (as opposed to points),
- a **time cumulation** of these best steps.

# Noisy optimization

## CMA-ES : adapting $C^2$ with good steps

(A. Auger et N. Hansen, 2008)

Initialization :  $m \in S$  ,  $C = I$  ,  $c_{cov} \approx 2/n^2$

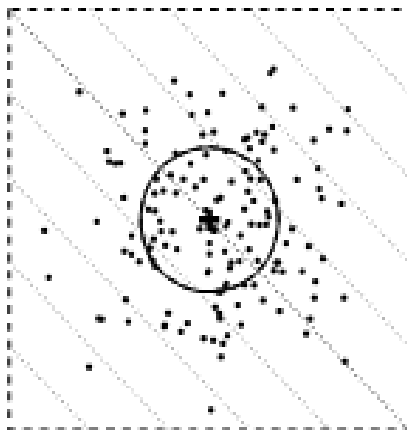

sampling

$$x^i = m + y^i$$

$$y^i \propto N(0, C)$$

$$i = 1, \dots, \lambda$$

calculate  $f$

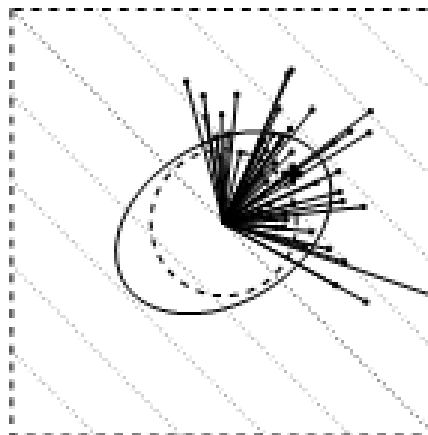

selection

$$y_w = \frac{1}{\mu} \sum_{i=1}^{\mu} y^{i:\lambda}$$

rank 1  $C$  update

$$C \leftarrow (1 - c_{cov})C + c_{cov} \mu y_w y_w^T$$

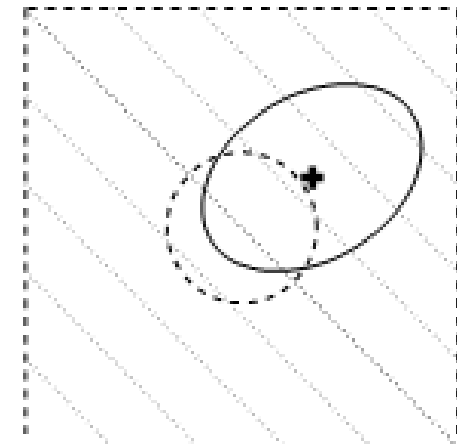

update  $m$

$$m \leftarrow m + y_w$$

## Noisy optimization

# The state-of-the-art CMA-ES

---

(A. Auger and N. Hansen, *A restart CMA evolution strategy with increasing population size*, 2005)

### Additional features :

- Steps weighting,  $y_w = \sum_{i=1}^{\mu} w_i y^{i:\lambda}$
- Time cumulation of the steps.
- Simultaneous rank 1 and  $\mu$  covariance adaptations.
- Use of a global scale factor,  $C \rightarrow \sigma^2 C$ .
- Restarts with increasing population sizes (unless it is the 2010 version with mirrored sampling and sequential selection, see later)

Has been used up to  $d \sim 1000$  continuous variables.

---

## Noisy optimization

- The general CMA-ES
- Improvements for noisy functions :  
Mirrored sampling and sequential selection



# Resampling, noise and evolutionary algorithms

---

$CMA-ES(\mu, \lambda)$  can optimize many noisy functions because

1. it is not elitist

2. the choice of the next iteration average

$$m^{t+1} = m^t + \frac{1}{\mu} \sum_{i=1}^{\mu} y^{i:\lambda}$$

averages out errors (spatial sampling as a proxy for  $U$  sampling)

To improve convergence on noisy function, is it preferable

1. to resample  $\hat{f}(x) = \frac{1}{K} \sum_{i=1}^K \hat{f}^{(i)}(x)$

2. or to increase the population size ?

(for an equivalent increase in computation)

→ it is better to increase the population size. [Beyer and Sendhoff 2007, Arnold and Beyer 2006]

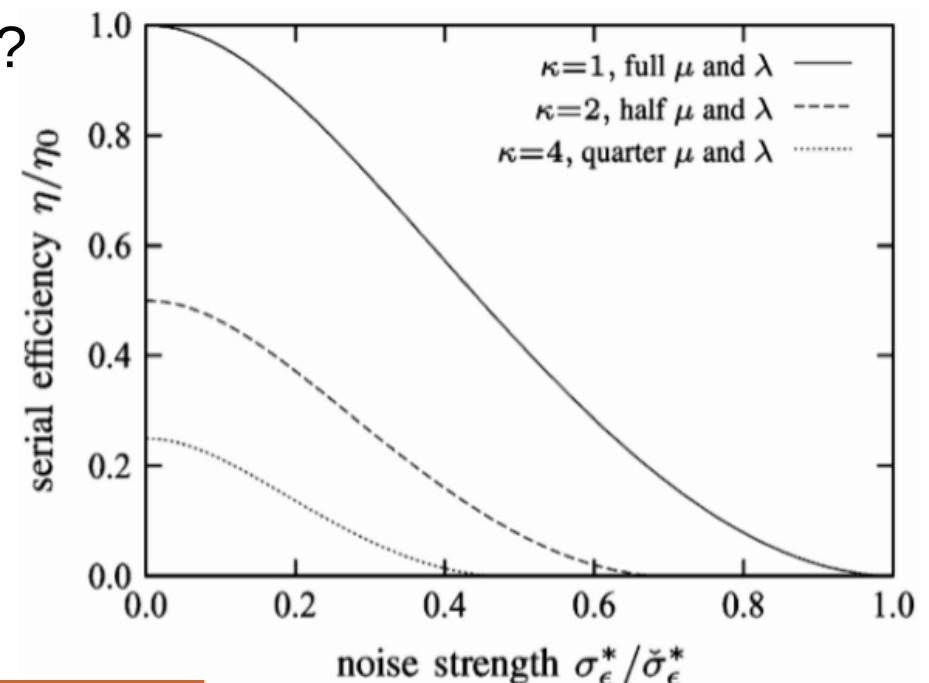

But one can still do better ...

---

# Noisy optimization, improved optimizers

## Mirrored sampling and sequential selection (1)

---

D. Brockhoff, A. Auger, N. Hansen, D. V. Arnold, and T. Hohm. *Mirrored Sampling and Sequential Selection for Evolution Strategies*, PPSN XI, 2010

A. Auger, D. Brockhoff, N. Hansen, *Analysing the impact of mirrored sampling and sequential selection in elitist Evolution Strategies*, FOGA 2011

(1+1)-CMA-ES with restarts surprisingly good on some functions (including multimodal functions with local optima)  
← small population advantage.

But « elitism » of (1+1)-ES bad for noisy functions : a lucky sample attracts the optimizer in a non-optimal region of the search space.

Question : how to design a fast local non-elitist ES ?

# Noisy optimization, improved optimizers

## Mirrored sampling and sequential selection (2)

---

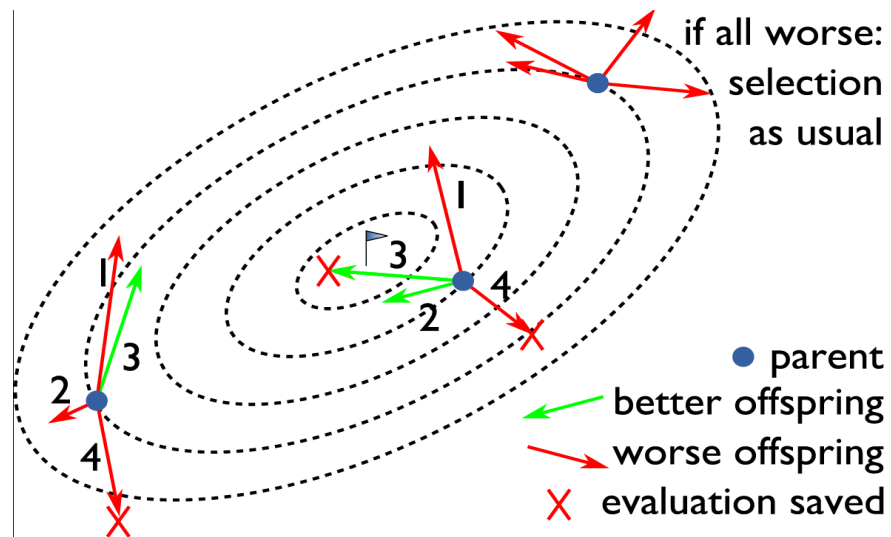
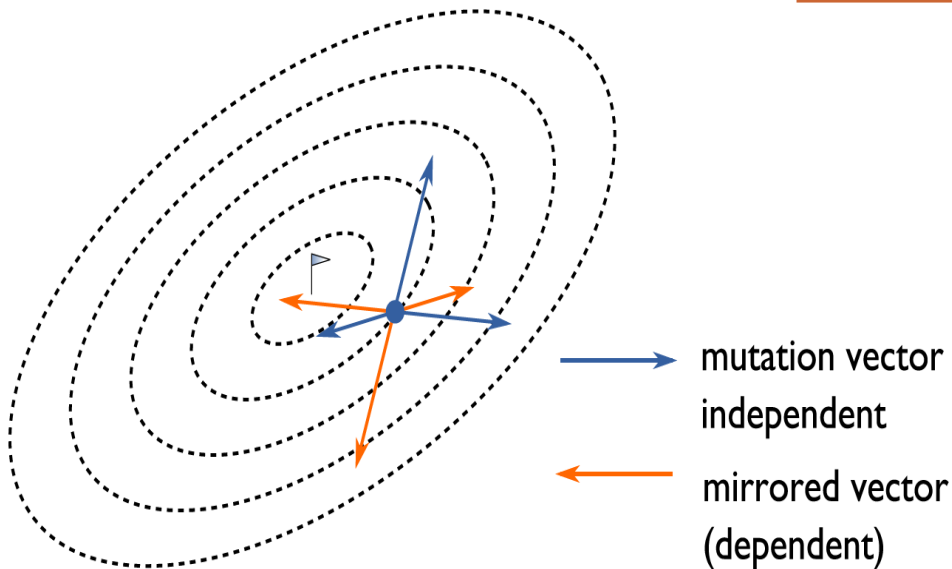

Derandomization via mirrored sampling : one random vector generates two offsprings. Often good and bad in opposite directions.

Sequential selection : stop evaluation of new offsprings as soon as a solution better than the parent is found.

Combine the two ideas : when an offspring is better than its parent, its symmetrical is worse (on convex level sets), and vice versa → evaluate in order  $m+y^1$  ,  $m-y^1$  ,  $m+y^2$  ,  $m-y^2$  , ... .

## Mirrored sampling and sequential selection (3)

---

### Results :

small population, no elitism

(1,4)-ES with mirroring and sequential selection faster than (1+1)-ES on sphere function.

Theoretical result: Convergence Rate\* ES (1+1)=0.202 ,  
Convergence Rate (1,4ms)=0.223 .

[ Brockhoff et al., Mirrored sampling and sequential selection for evolution strategies, 2010. ]

Implementation within CMA-ES, tested in BBOB'2010\*\* (Black Box Optimization Benchmarking)

*Best performance among all algorithms tested so far on some functions of noisy testbed*

\* convergence rate  $\equiv -\lim_{t \rightarrow \infty} \frac{\ln(\text{distance to optimum})}{t}$  ,

cf. slope line of  $(\log(f), \text{time})$  earlier

\*\* <http://coco.gforge.inria.fr/bbob2010-downloads>



# Concluding remarks (1)

---

## Today's story was :

- Optimization → difficult in the presence of noise → formulation of optimization in the presence of uncertainties → noisy functions
- → do spatial stats (kriging) [optimizer without U control → optimizer with U control]
- → stochastic optimizers directly applied to noisy functions.

## Each method has its application domain :

- Stochastic optimizers robust to noise cannot be directly applied to an expensive (simulation based) objective function. An intermediate surrogate is needed.
- Vice versa, kriging based method involve large side calculations : they are interesting only for expensive  $f$ 's.

## Concluding remarks (2)

---

Many (most) methods were not discussed :

- Method of moments (Taylor expansions of the opt. criteria),
- FORM/SORM (local constraints approximations about probable points),
- Chance constraints and convex programming (worst U cases) ... .

A lot still to be done :

- effect of the a priori uncertainty model (law of random parameters),
- optimize quantiles,
- statistically joined criteria,
- kriging like approaches (spatial stats) in high dimension,
- ...

# Bibliography

---

## Related books :

- A. Ben-Tal, L. El Ghaoui, A. Nemirovski, *Robust Optimization*, Princeton Univ. Press, 2009.
- R. E. Melchers, *Structural Reliability Analysis and Prediction*, Wiley, 1999.
- M. Lemaire, A. Chateauneuf, J.-C. Mitteau, *Structural Reliability*, Wiley, 2009.
- J. C. Spall, *Introduction to Stochastic Search and Optimization*, Wiley, 2003.
- *Multidisciplinary Design Optimization in Computational Mechanics*, P. Breitkopf and R. Filomeno Coehlo Eds., Wiley/ISTE, 2010.

## Articles :

- H.G. Beyer, B. Sendhoff, *Robust Optimization – A comprehensive survey*, Comput. Methods Appl. Mech. Engrg, 196, pp. 3190-3218, 2007.
- J. Janusevskis and R. Le Riche, *Simultaneous kriging-based estimation and optimization of mean response*, Journal of Global Optimization, Springer, 2012
- G. Pujol, R. Le Riche, O. Roustant and X. Bay, *L'incertitude en conception: formalisation, estimation*, Chapter 3 of the book *Optimisation Multidisciplinaire en Mécaniques : réduction de modèles, robustesse, fiabilité, réalisations logicielles*, Hermes, 2009 (in French)
- D. Salazar, R. Le Riche, G. Pujol and X. Bay, *An empirical study of the use of confidence levels in RBDO with Monte Carlo simulations*, in *Multidisciplinary Design Optimization in Computational Mechanics*, Wiley/ISTE Pub., 2010.